

AlbaBird FPV

User Manual



FinWinghobby
Finwinghobby

WWW.FINWINGHOBBY.COM

FINWING TECHNOLOGY
PATENT OWNER: FINWINGHOBBY

Please read through the manual before installation and flying

This manual as introductions to user on how to building this RC plane.
Please visit the [www. finwinghobby. com](http://www.finwinghobby.com) official website for more introductions.

Warning:

1. This model airplane is not a toy, not recommended for children under 14 years old,
2. Be cautious and prepared while flying this plane as a range of issues could lead to a crash including the environment/weather, speed, pilot error, improper building/testing, interference or other component failures.
3. Flying field: Choose an adequate flying space at least 100 meters long/wide and in an unpopulated and non-built up area for safe flying. This includes avoiding flying over cities or other populated areas.
4. Please don't fly this model airplane in bad weather including rainy and/or windy environments.
5. Remember to unplug your flight/video battery when not in use to avoid any interference to others who might be on similar channels.
6. Please remember switch on the transmitter first before connecting the battery, and disconnect the battery first before switching off your transmitter.
7. Keep away from the propeller when the Airplane is powered as it can be dangerous and could lead to injury. Keep the powered plane away from children at all times to avoid any accidents or injury.

Will post the information on time to weixin and facebok once we have new airplane for sales or big discount promotions

Be the first one to knew!

Subscribe

Finwinghobby WeiChat



Like us

(Facebook Page)



CG.

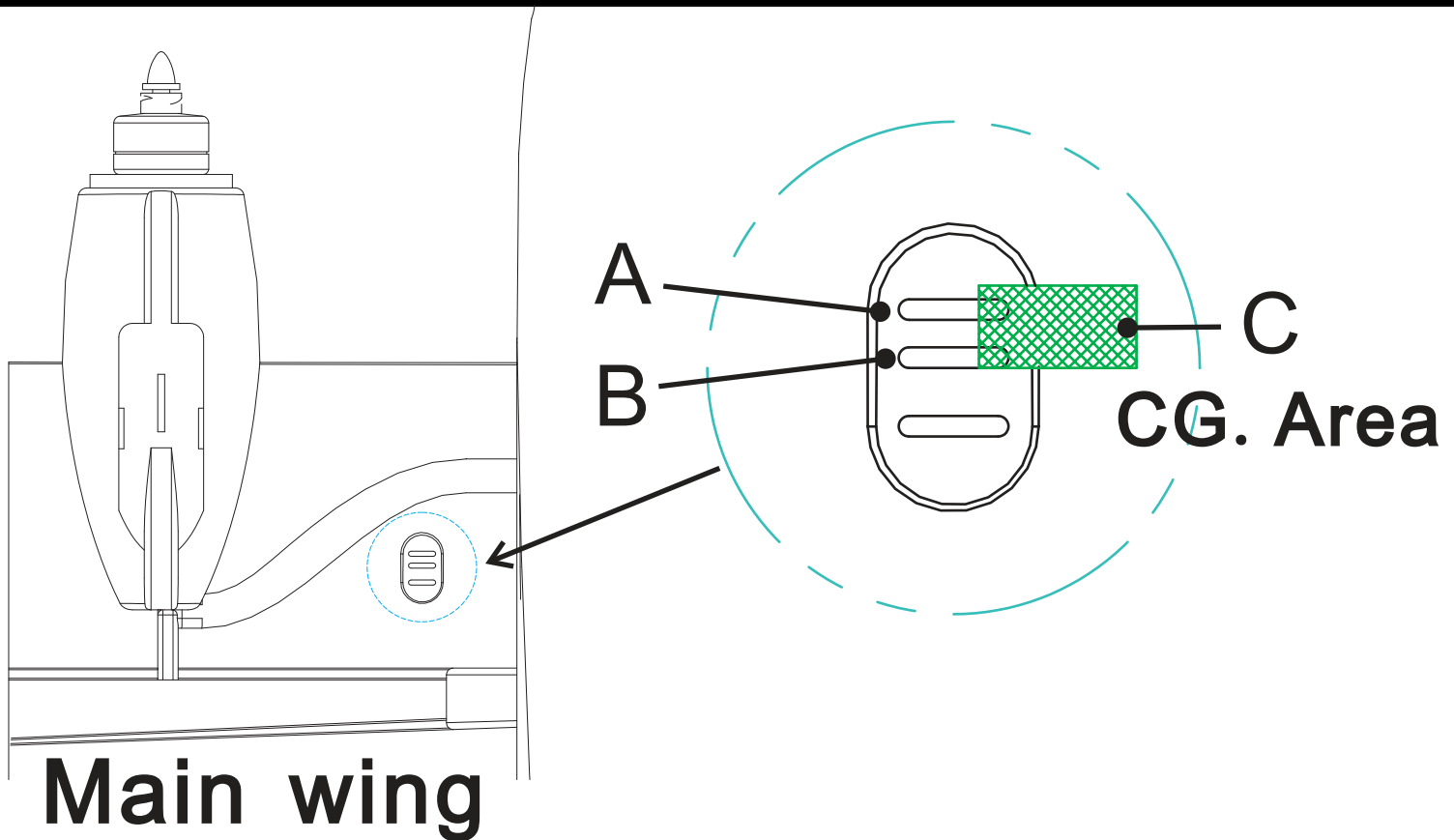

CG. Setting introductions:

Green area C

After lots of testing concluded CG. must be in the Green Area

Point B: For safety purpose recommend Maiden flight use Point B

Point A: if plane assemble correctly, we found that A is the best

Different people measuring differently by fingers

Moving CG. backward a little (3mm) if plane pitch down tendency

Moving CG. forward a little (3mm) if plane pitch up tendency

if still not good after CG. Adjustment, must checking horizontal wing and main-wing especial after crash happened!

Special Recommendations

We have solved potential problems by new design and improving Mould making but what ever in case we still introduce this for your reference

In case nose heavy:

plane still nose heavy diving a lot even if CG. is at Point B

Solutions:

Elevator up approximately 1.5MM travel as following picture
CG. is still between A and B

What caused ?

Horizontal wing should be exactly horizontal but fuselage tail section has to be molded by two half, transportation may caused horizontal wing to be deformed or not drying properly after gluing etc.

All of these may caused horizontal wing pitch up

a pitch up horizontal wing definitely forced the plane nose down diving

But But if installing properly and horizontal wing not deformed this won't happened!

At last Reminder:

must let fuselage drying at least 12 hours after gluing together to avoid that problem

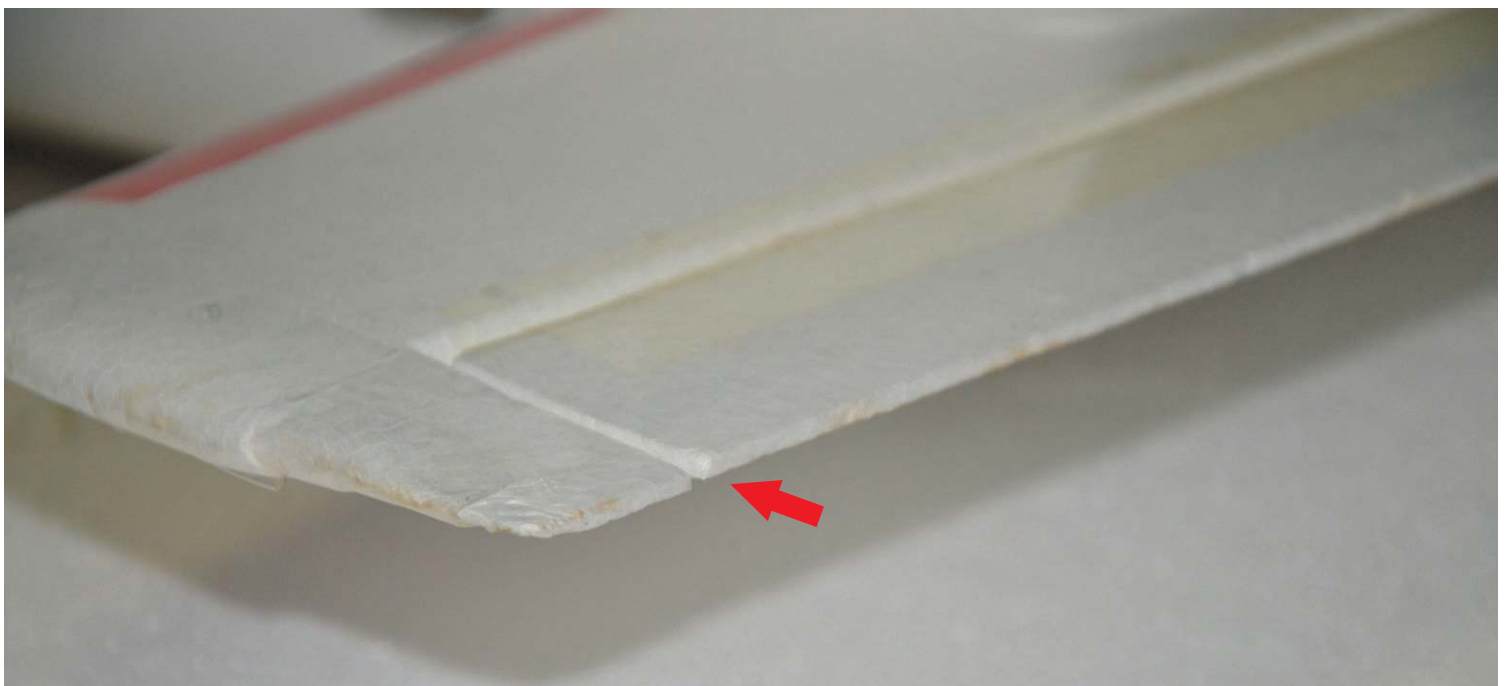

Airframe Building

Please do to building as per instructions as below step by step

1

Glue vertical wing

Install properly and drying

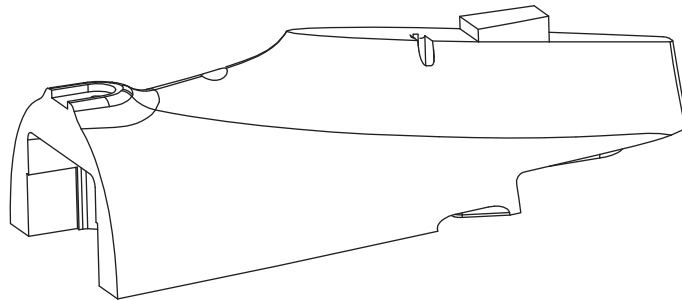
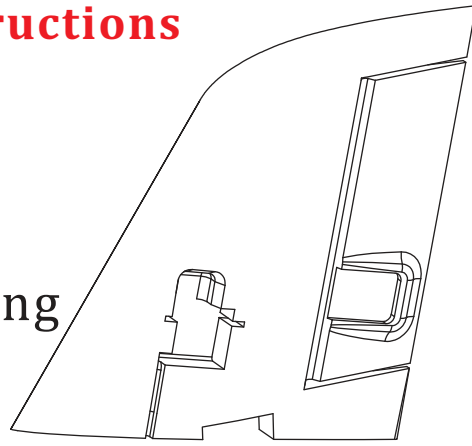

2

Glue Fuselage

Note: Don't install wings and other devices until drying at least 12 hours

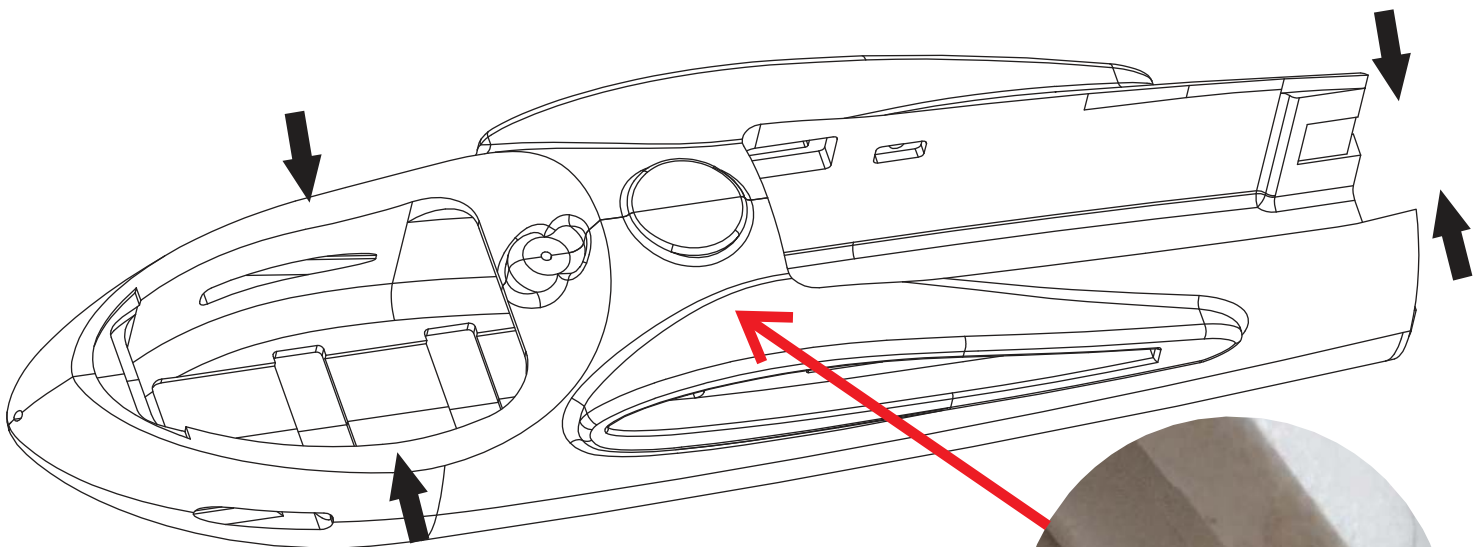

Detachable Fuselage

Non-detachable fuselge please skip to next page

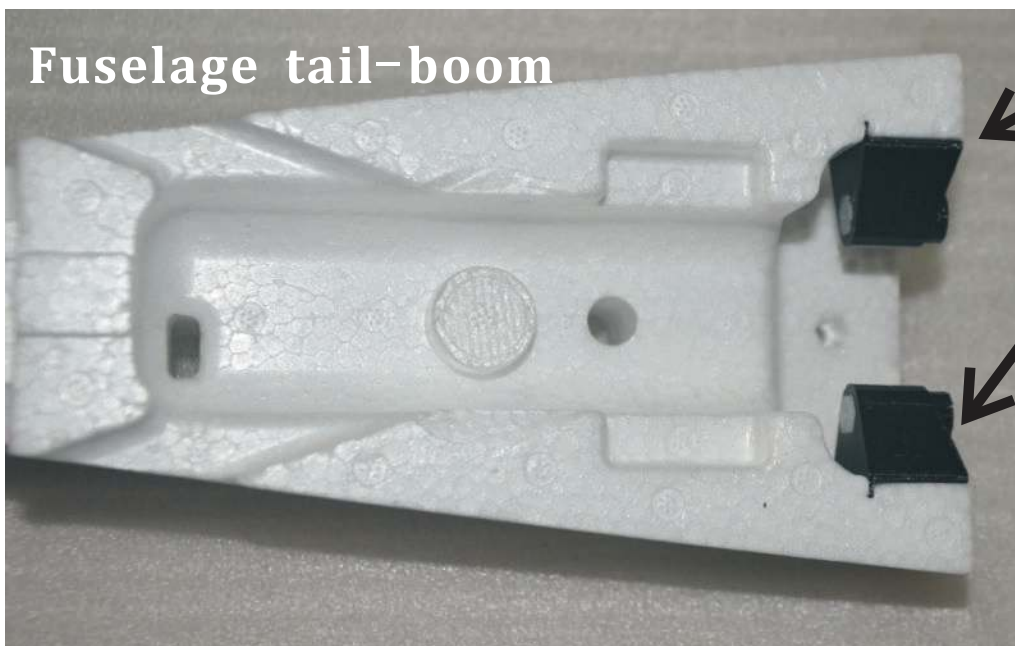
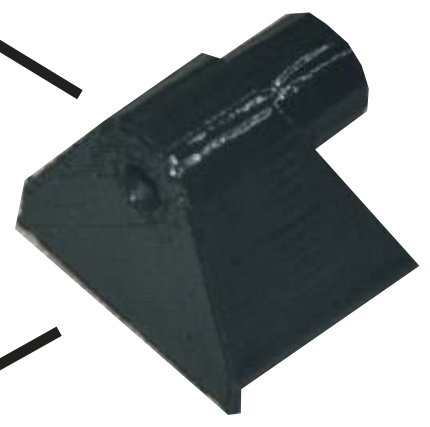
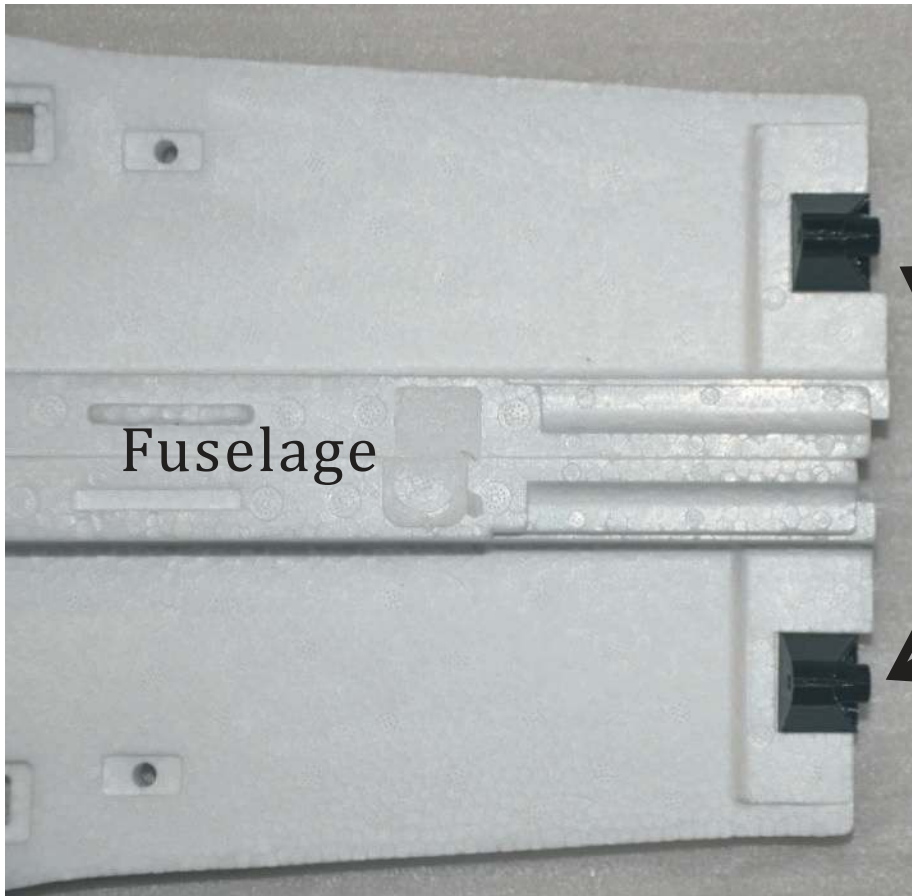

Airframe Building

3 Plywood

plywood reinforcements

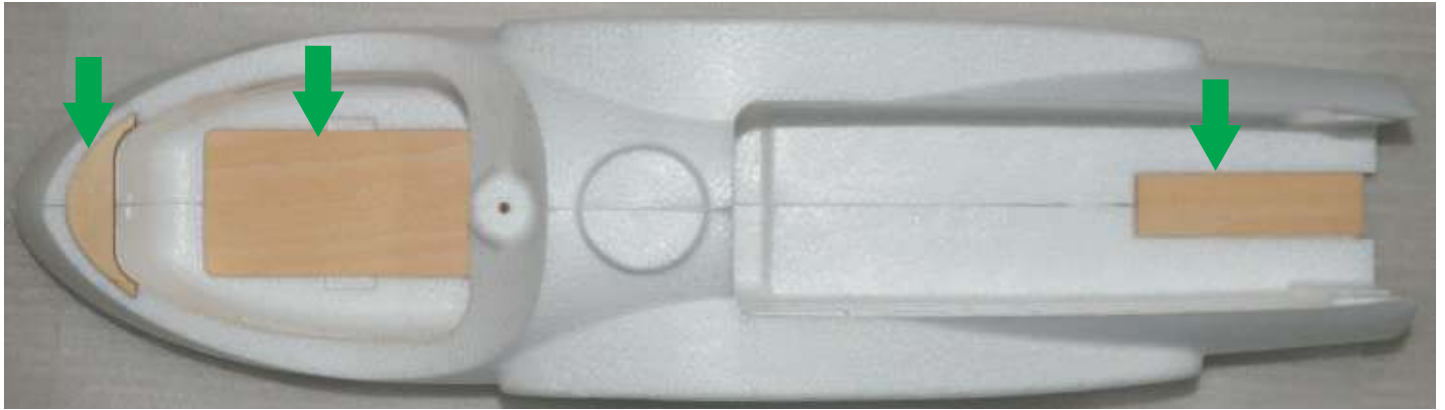
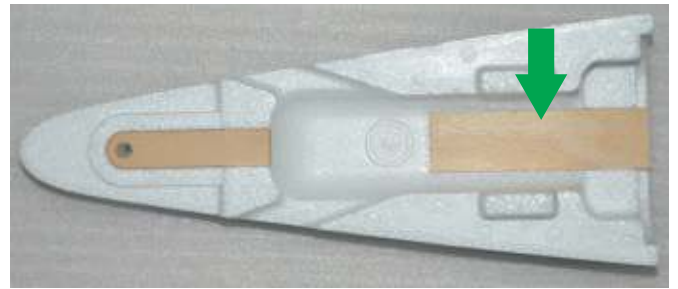

Detachable fuselge must install rods

Standard Non-Detachable fuselge no need to install rods, please skip to next page

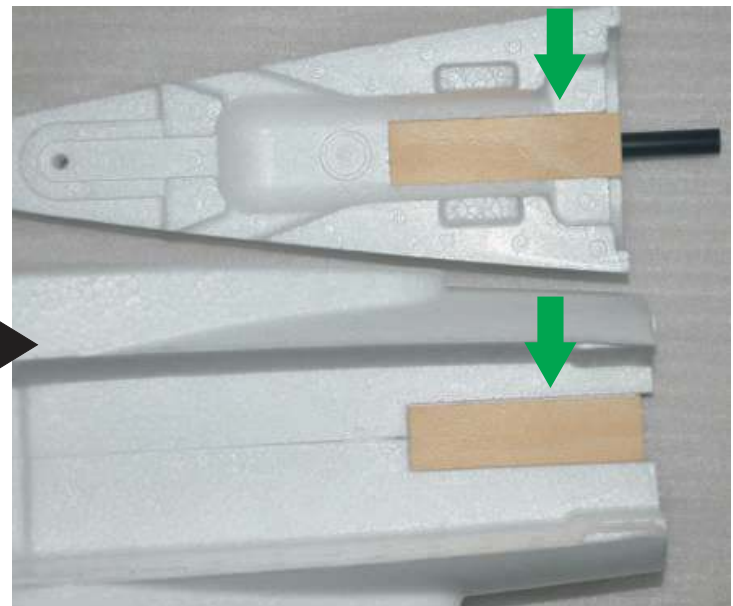
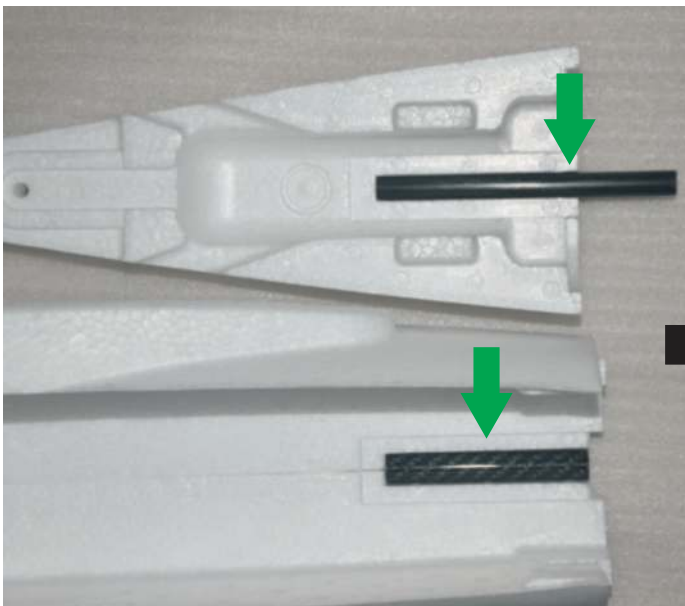

Airframe Building

We can build main-wing now, let fuselage glue drying

4 Glue motor mounts



Reminder with this remarks to the right wing

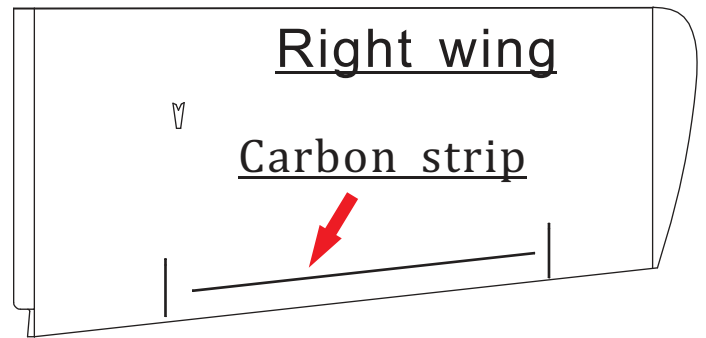
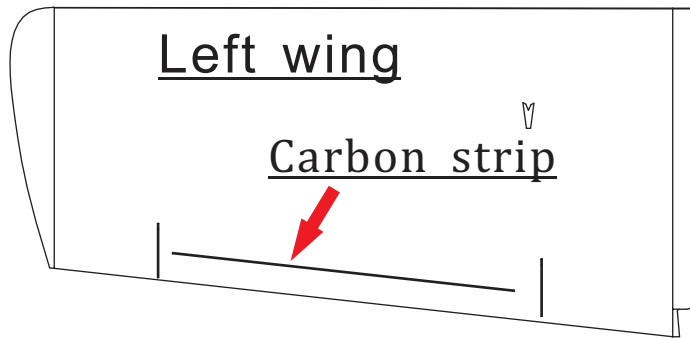

Glue properly to the red area drying one minutes then install properly to the main-wing

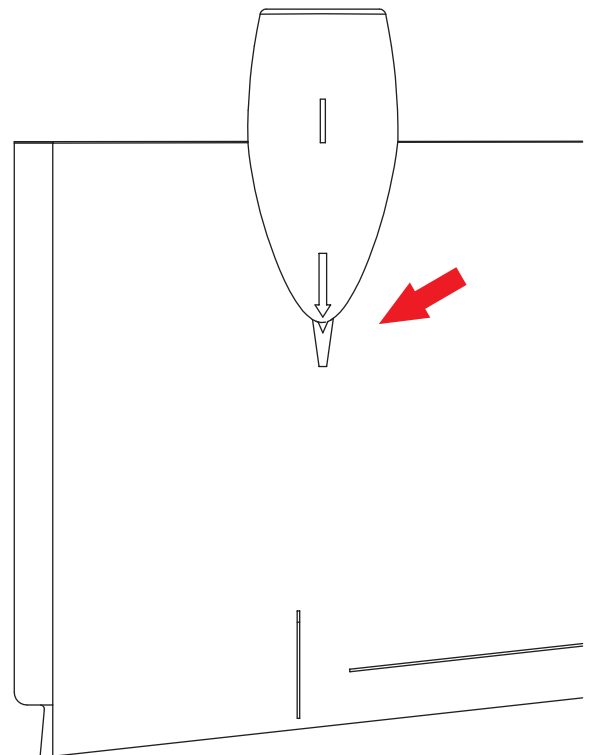
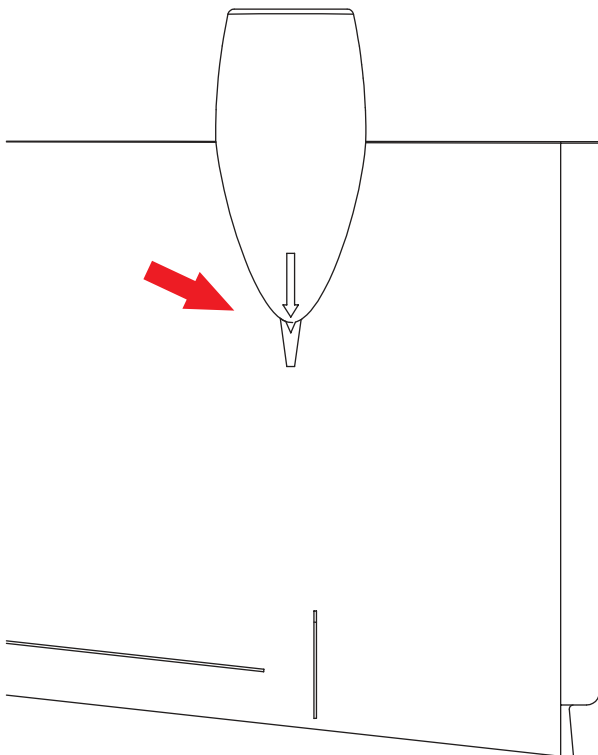

Airframe Building

5 Glue tail-boom

Reminder: must drying at least 1 hour before continuing to step 6

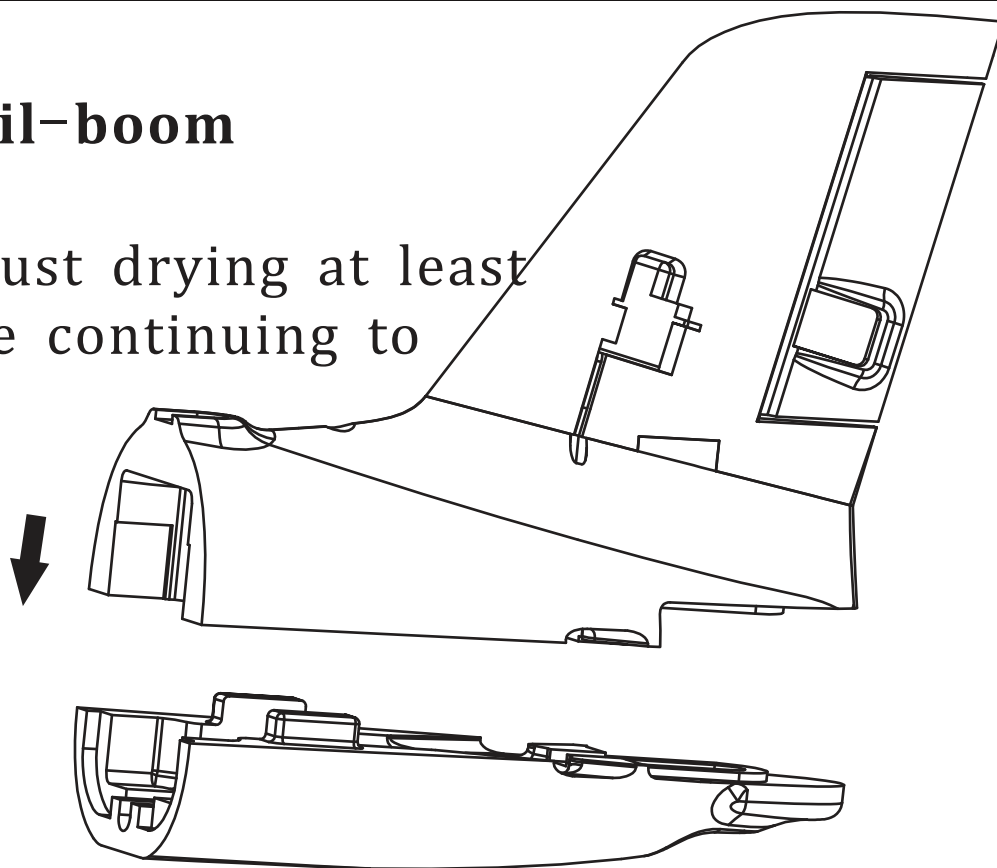

(Detachable Fuselage please skip)

6 Glue tail-boom to fusealge

Reminder: must let fuselage drying at least 12 hours this is very important, otherwise may cause horizontal wing wrongly pitch up

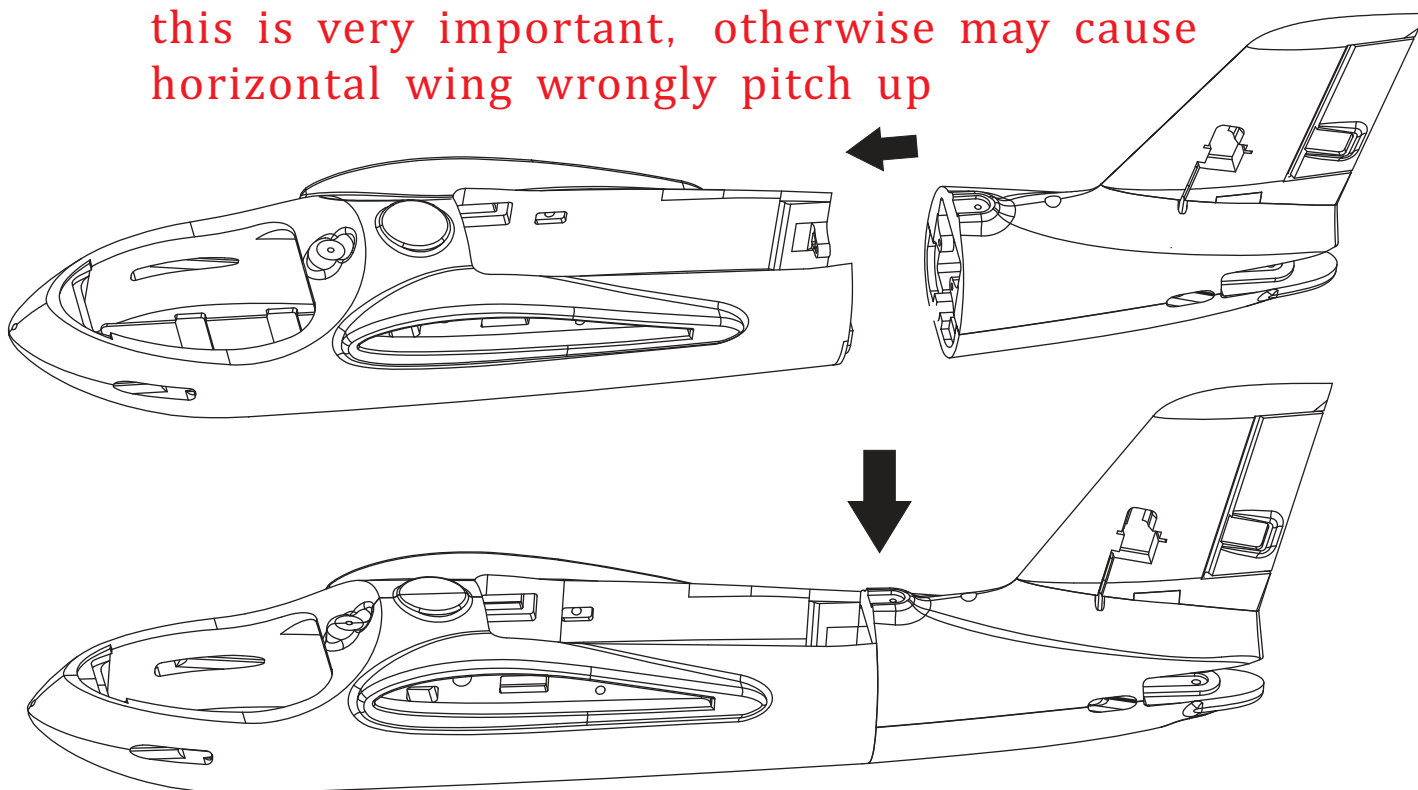

Airframe Building

(Detachable fuselage please skip)

Let it stand up like this drying 12 hours

2020 Newly added this plywood
For Non-Detachable fuselage
<[No need for detachable fuselage](#)>

Gule to fuselage
for reinforcement

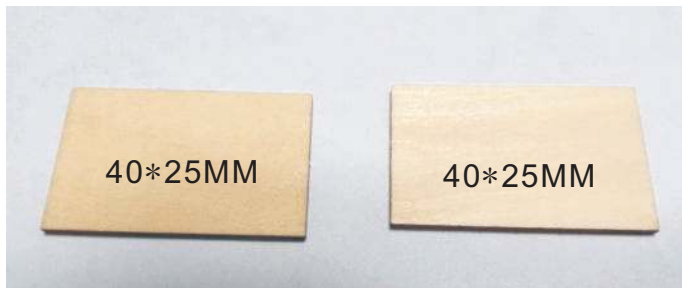

Ground

9+2 Connector

Male

Female



No regular rules on how to solder wires
do as per your requirements freely

Female to Wings

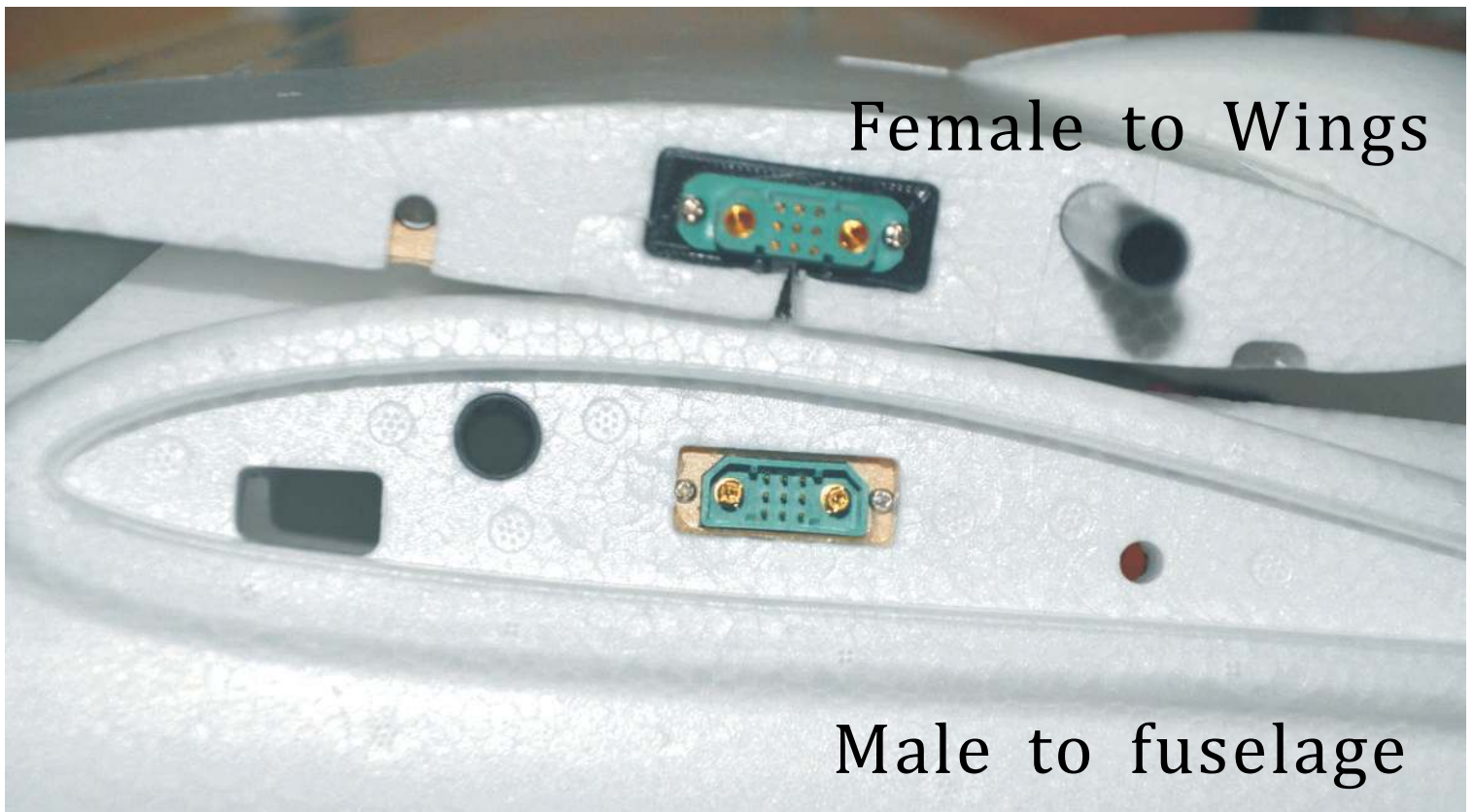

Male to fuselage

Screws secured Male connector
to fuselage



Screws for
Female Connector



Standard 9PIN Connector

9PIN Male

9PIN Female



(Male to Fuselage, Female to Wing)

There is no regular wire connection,
Please do according to your devices' wires
as below just for your reference



Standard 9PIN Connector

Reminder: Correct Orientation

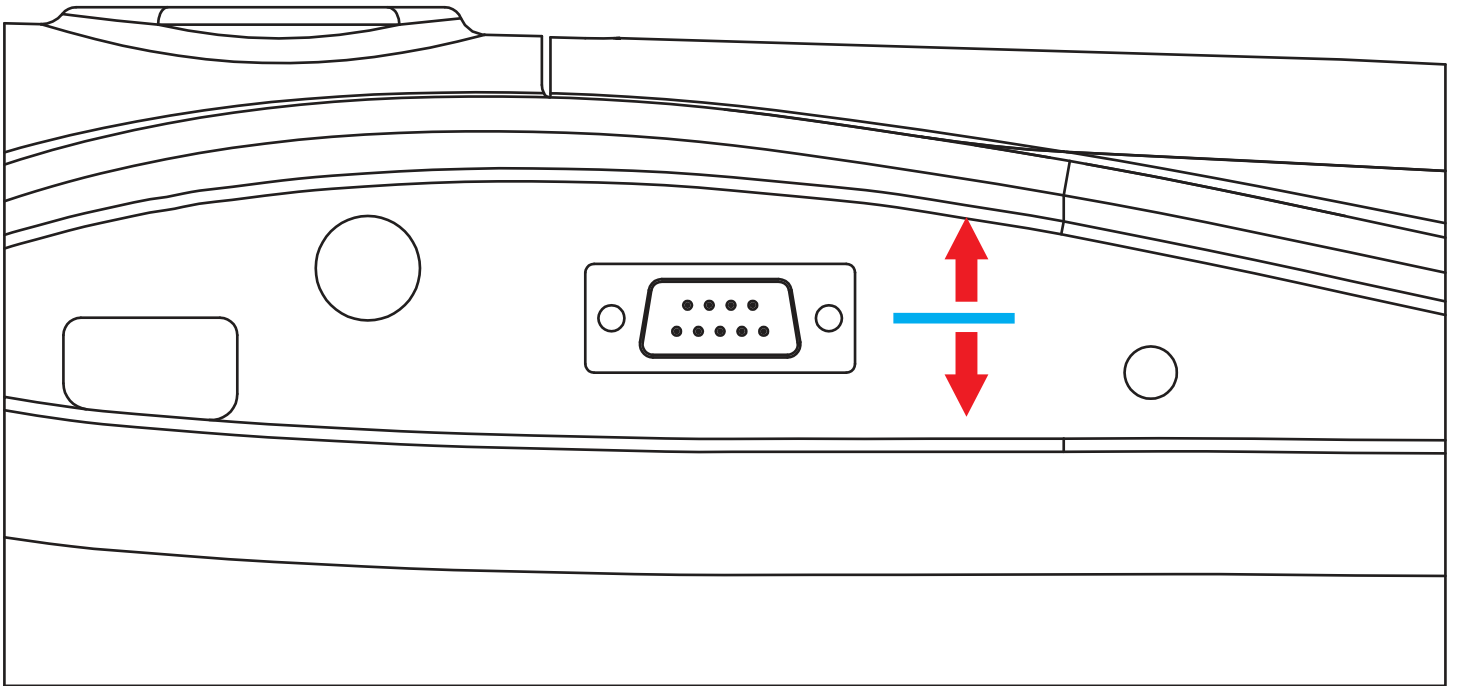

Finally secured by screws



Motor, ESC, Servo

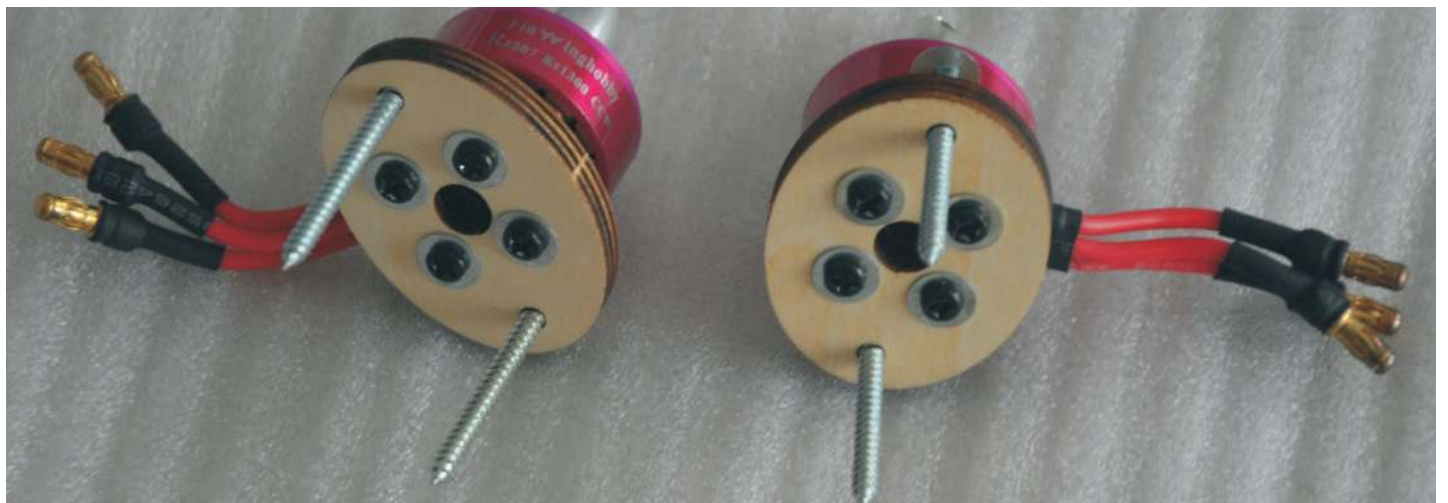
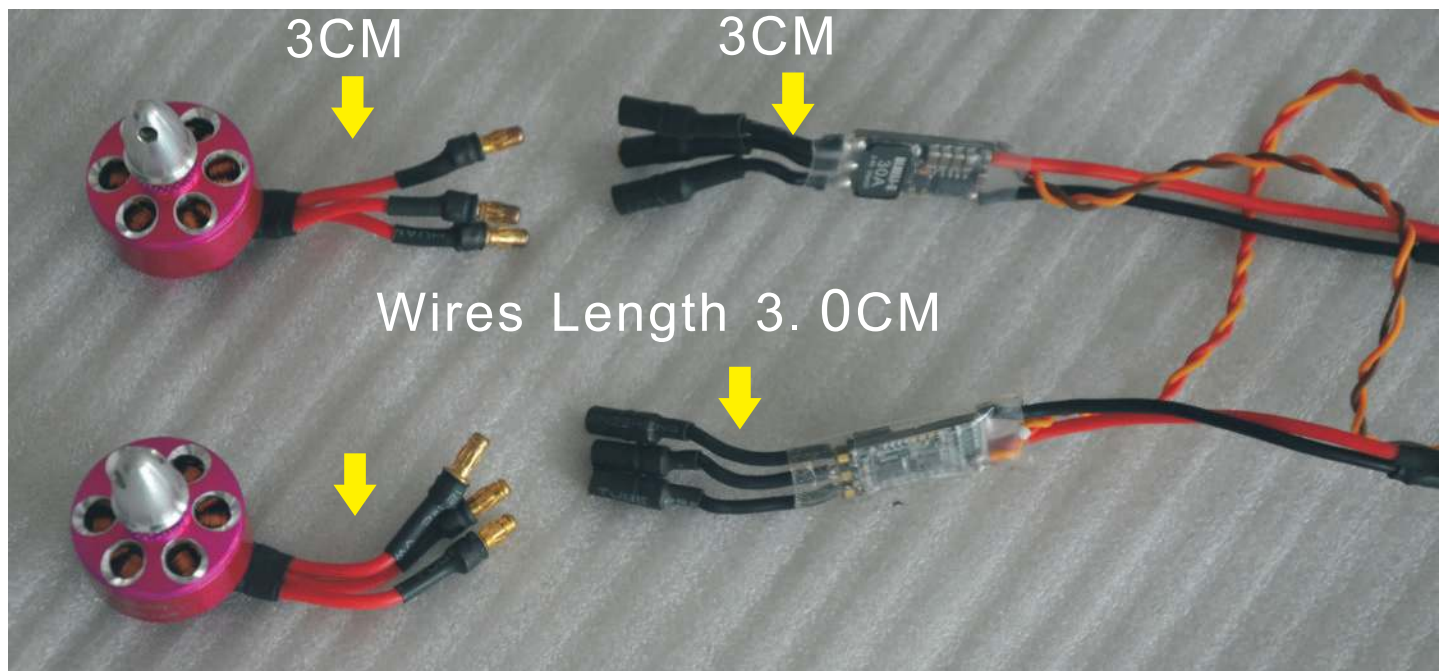

Motor, ESC, Servo

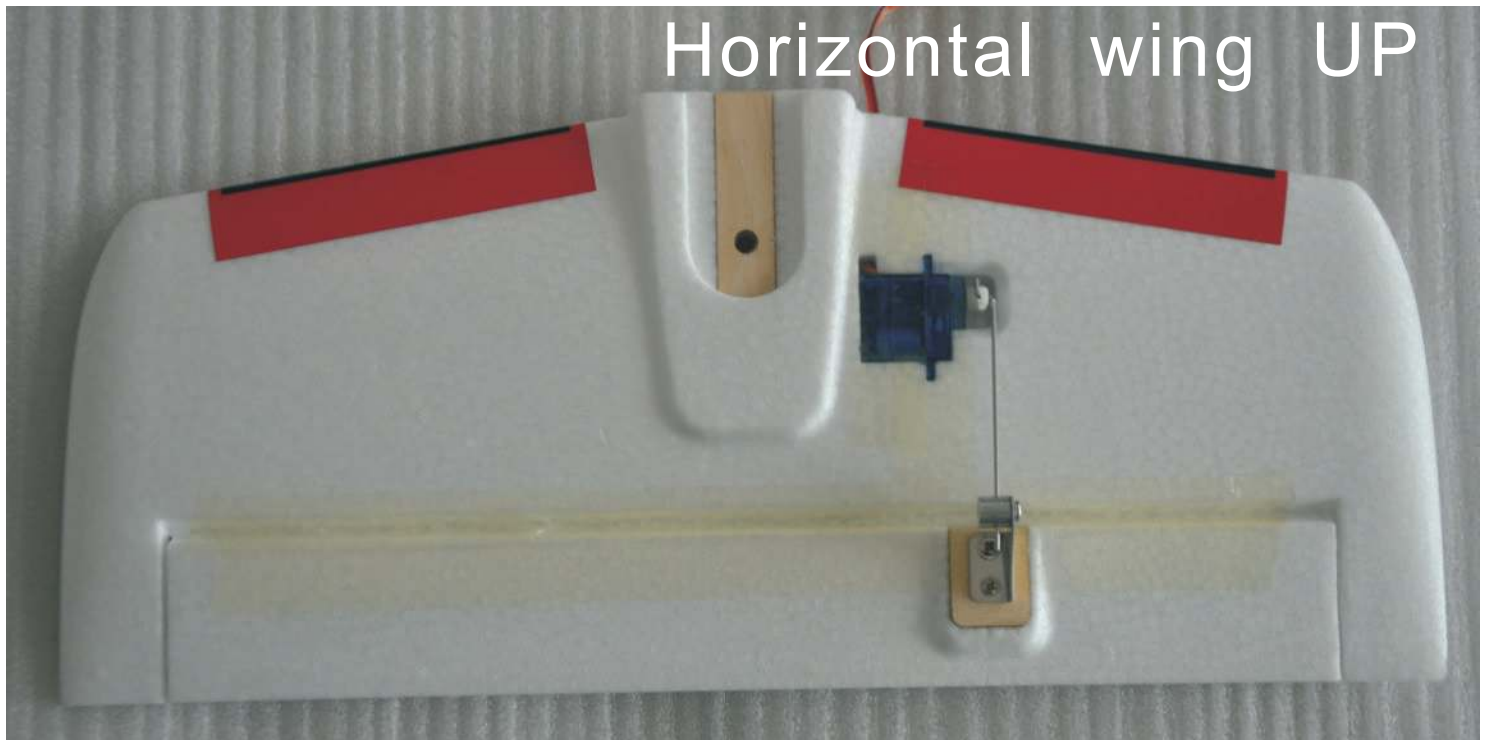
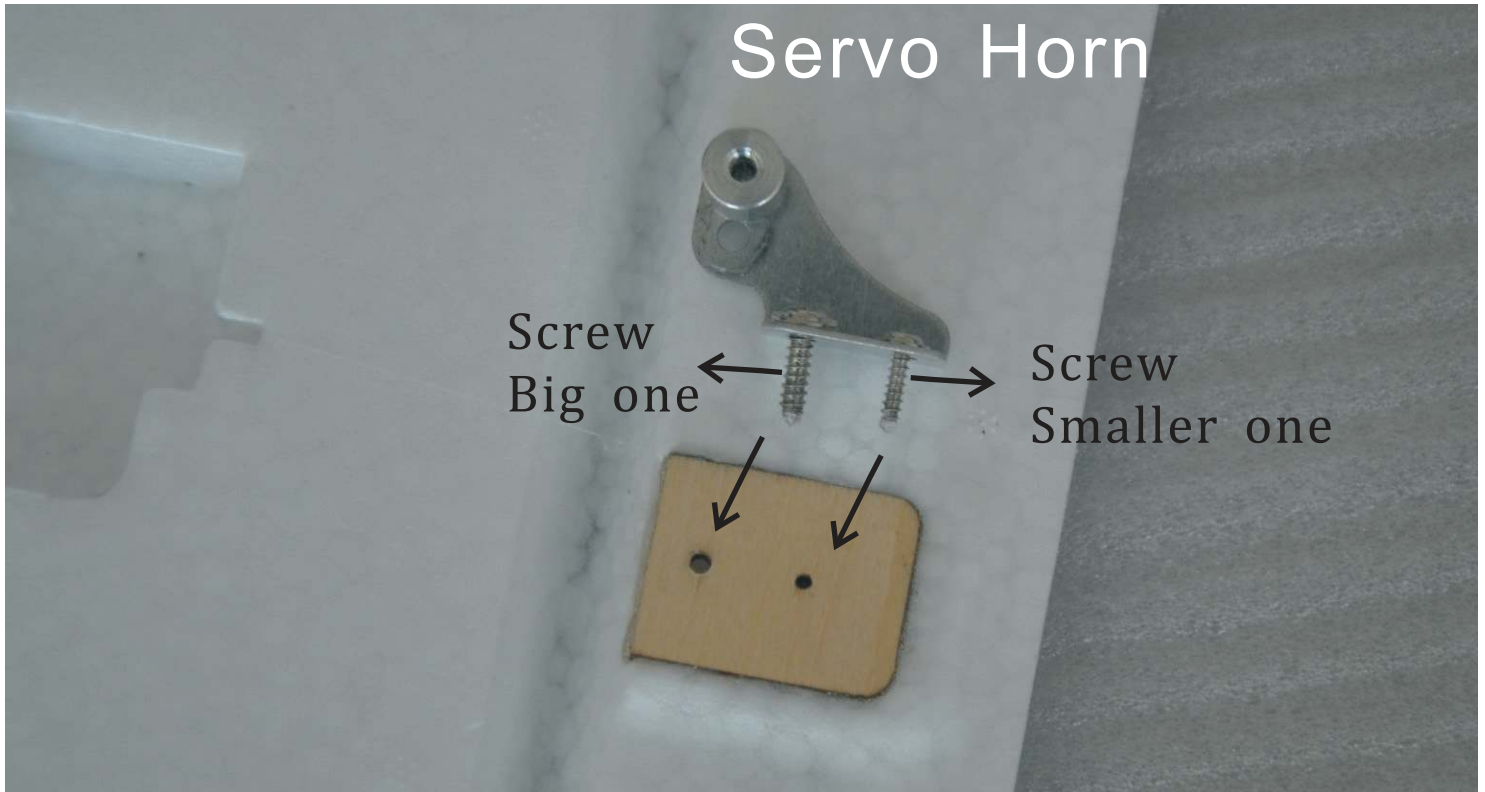

New Servo Horn introductions

Orders after July 2020 will use this new servo horn

Newly upgraded Servo Horn

Use Left Screw to
secure the push rod



Right Screw was fixed
don't screw off

Front 2.6*8
Rear 2.0*6

This is old one before upgrading



Old one

New One



Motor, ESC, Servo

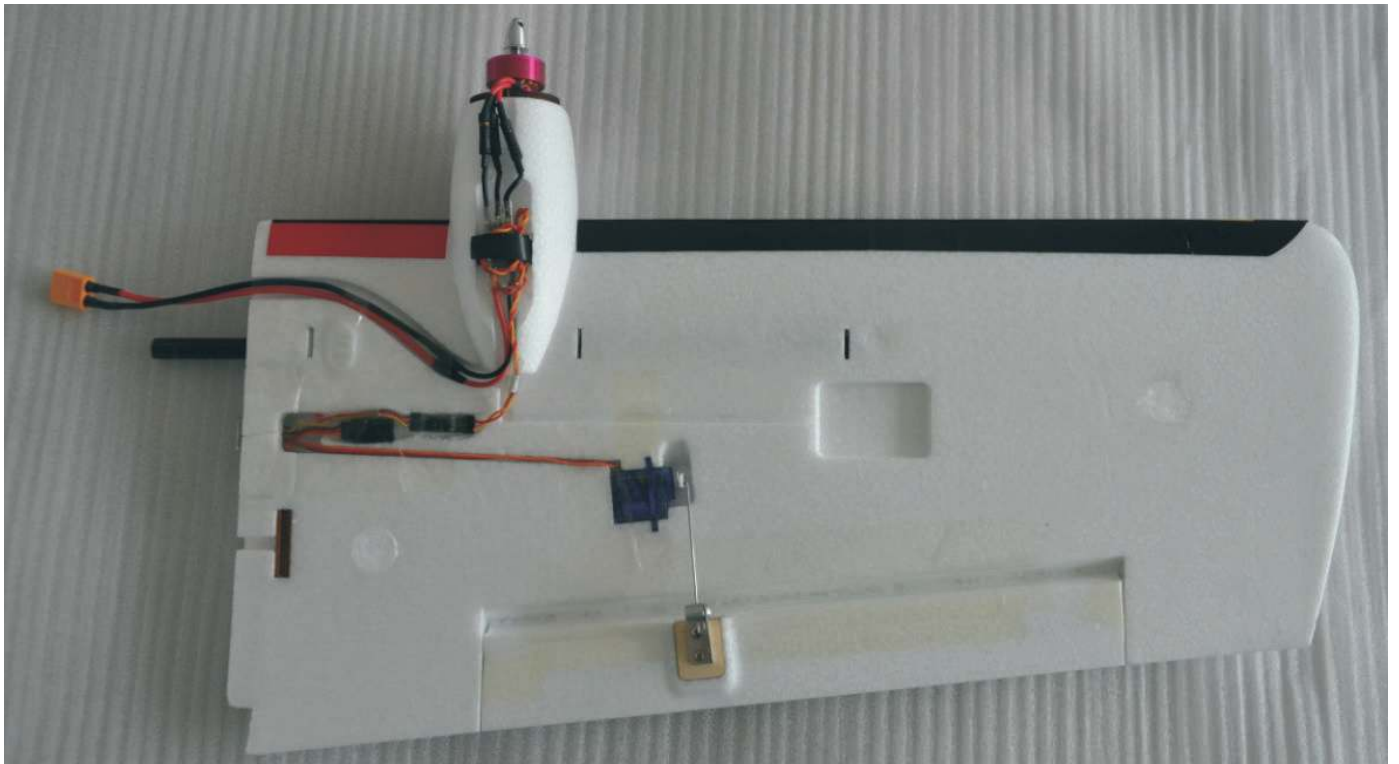

Main-wing



Rudder



9+2 Building

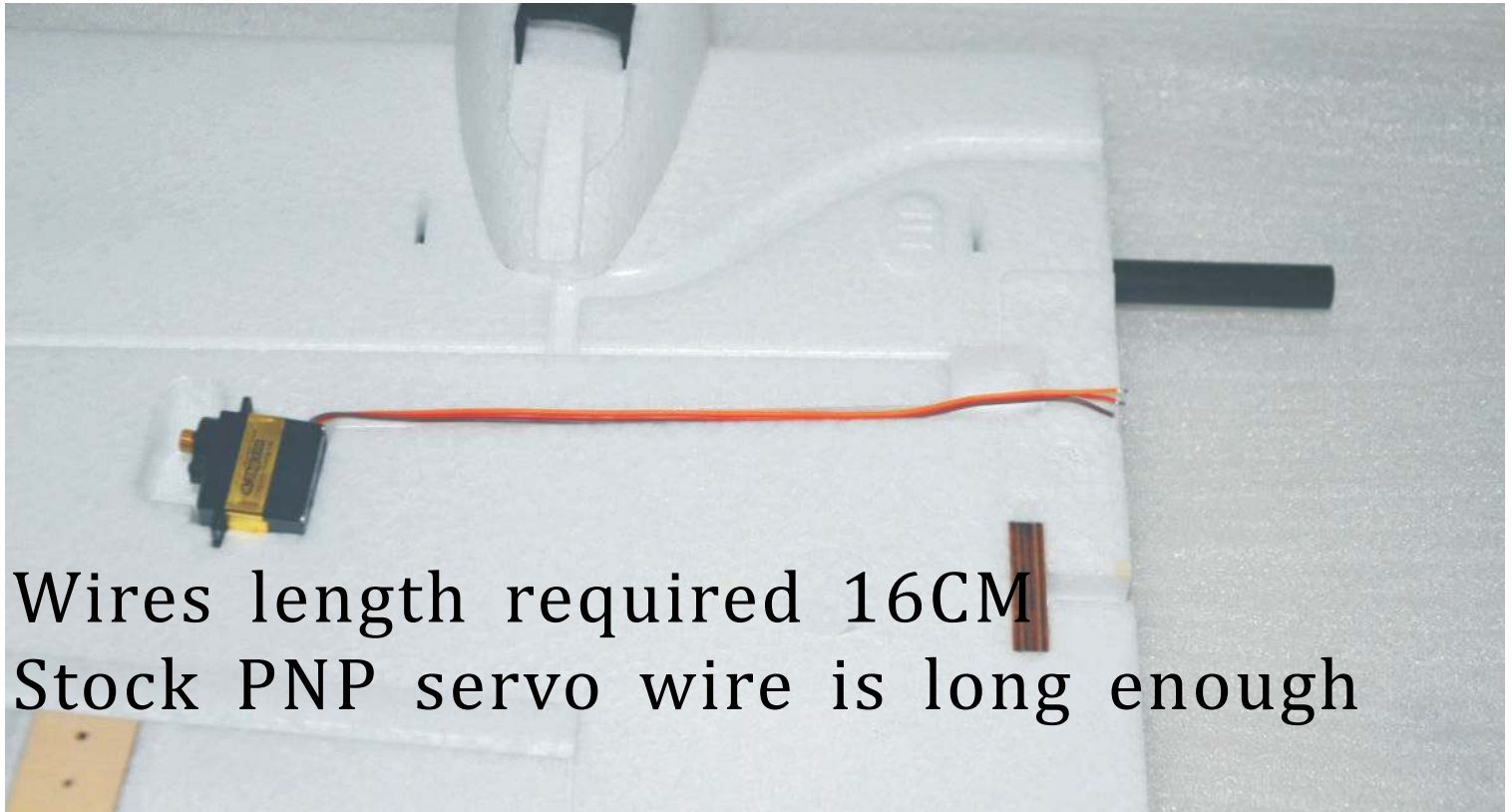

Wires length required 16CM
Stock PNP servo wire is long enough

Figure out proper wire length for your devices
soldering to the 9+2 connector directly



ESC Power wires recommend 18AWG is fine

9+2 Building

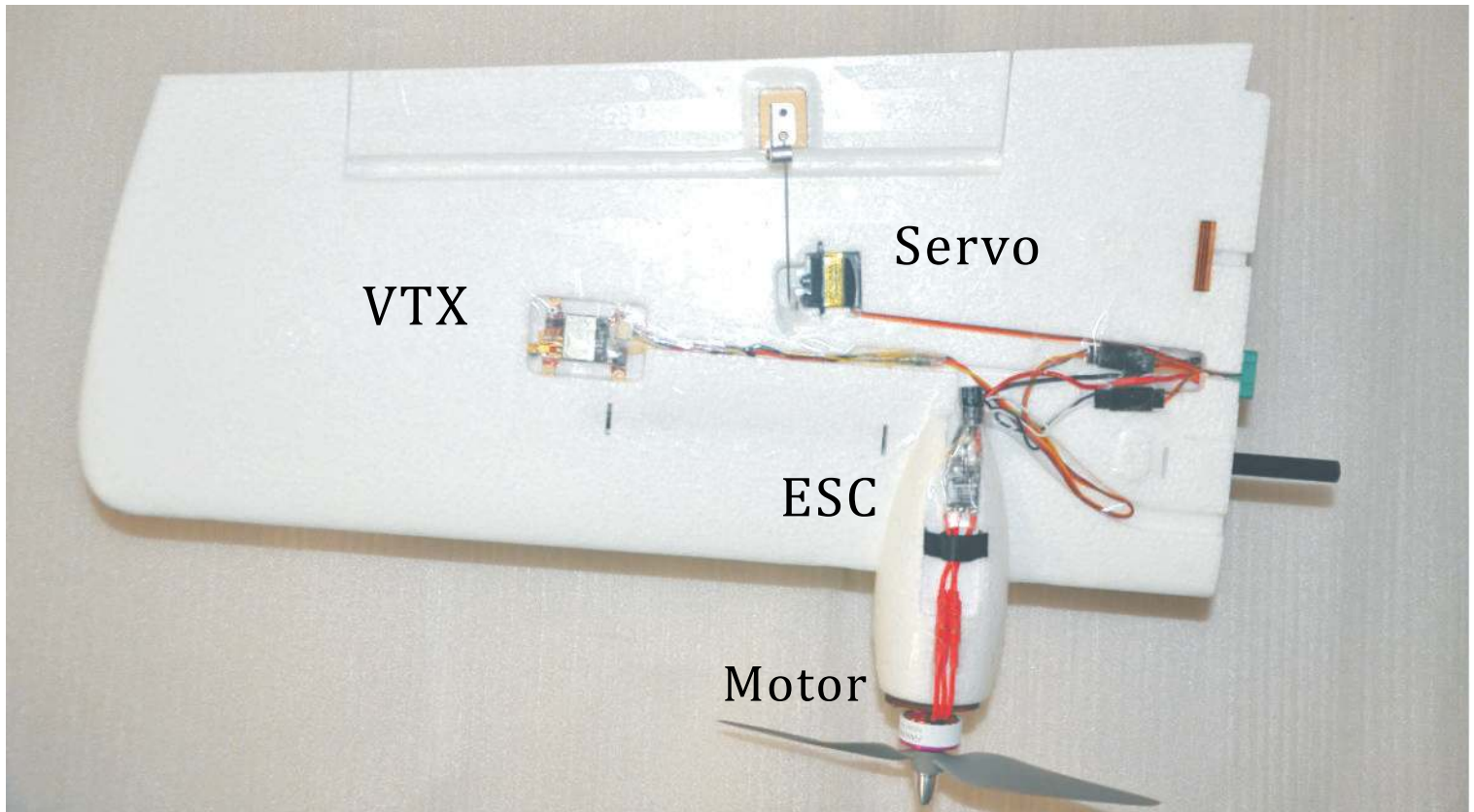

Show in the manual is for you reference only
you can do as per your preference

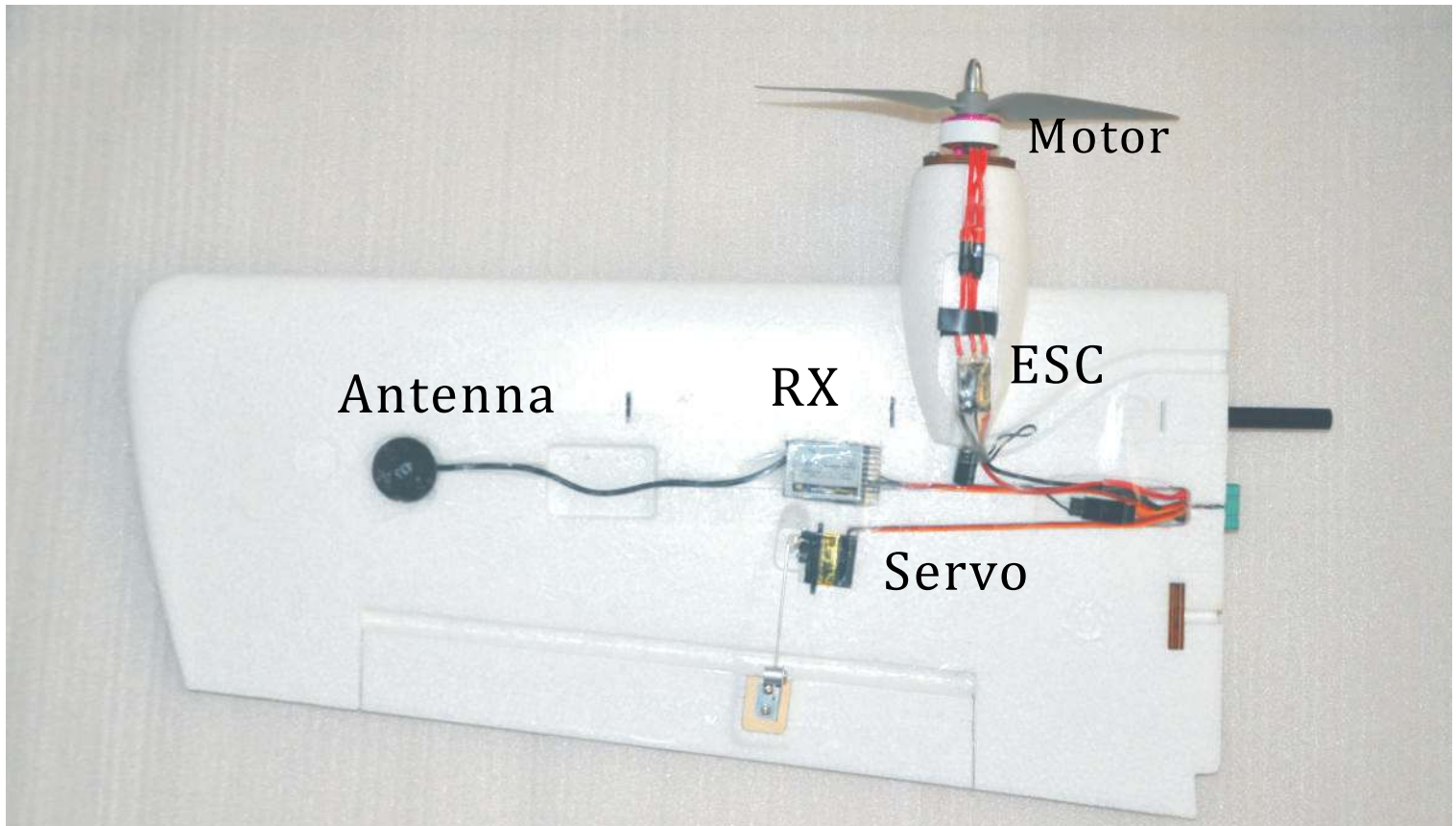

9+2 Building

Finished male ready to install to fuselage
Shrink film or Hot Melt Glue
to prevent it from loosing

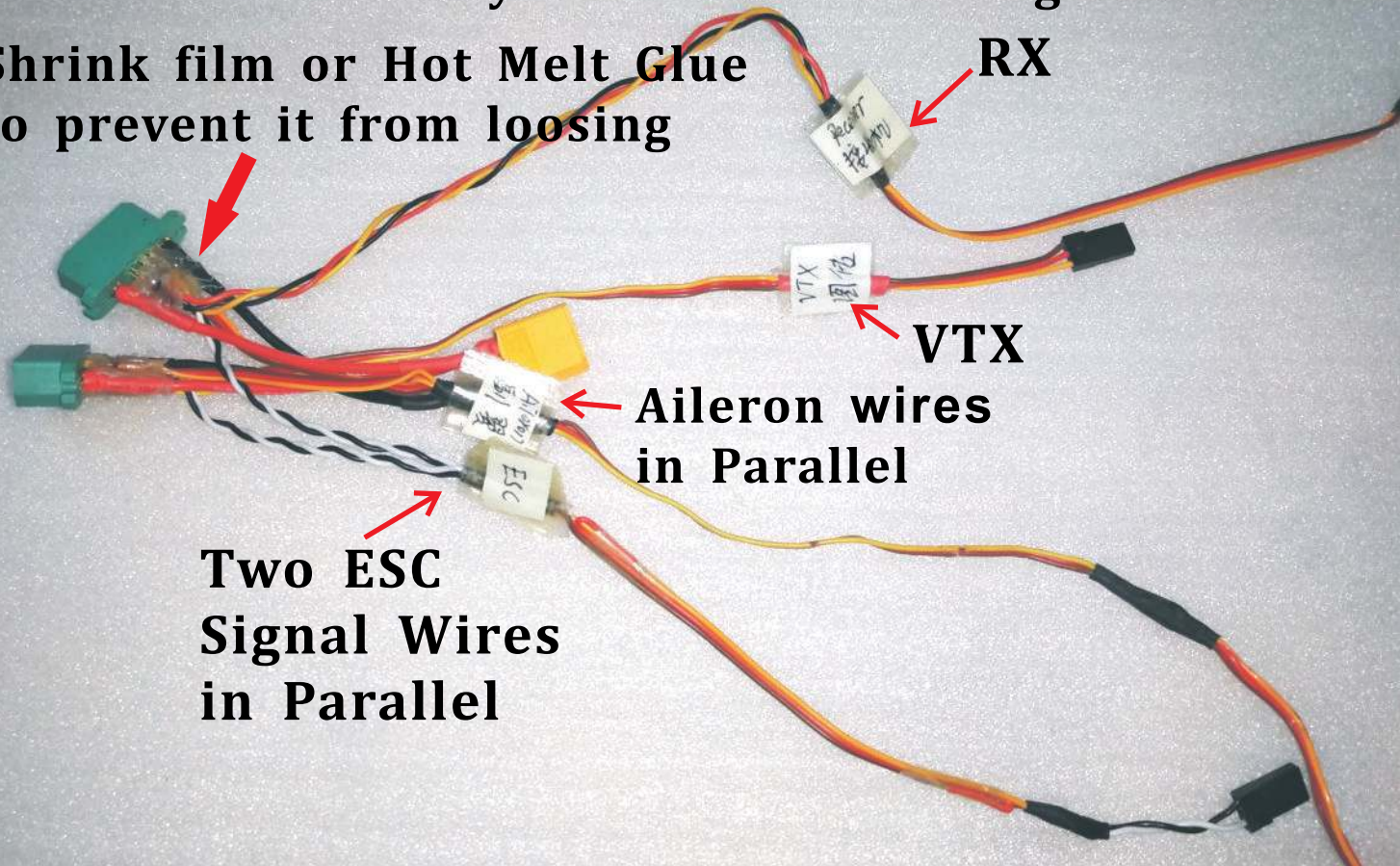

Two ESC
Signal Wires
in Parallel

Aileron wires
in Parallel

VTX

RX

You can solder all devices and wires before installing to fuselage
Because it is removable freely, connector could be installed
from inside instead of outside

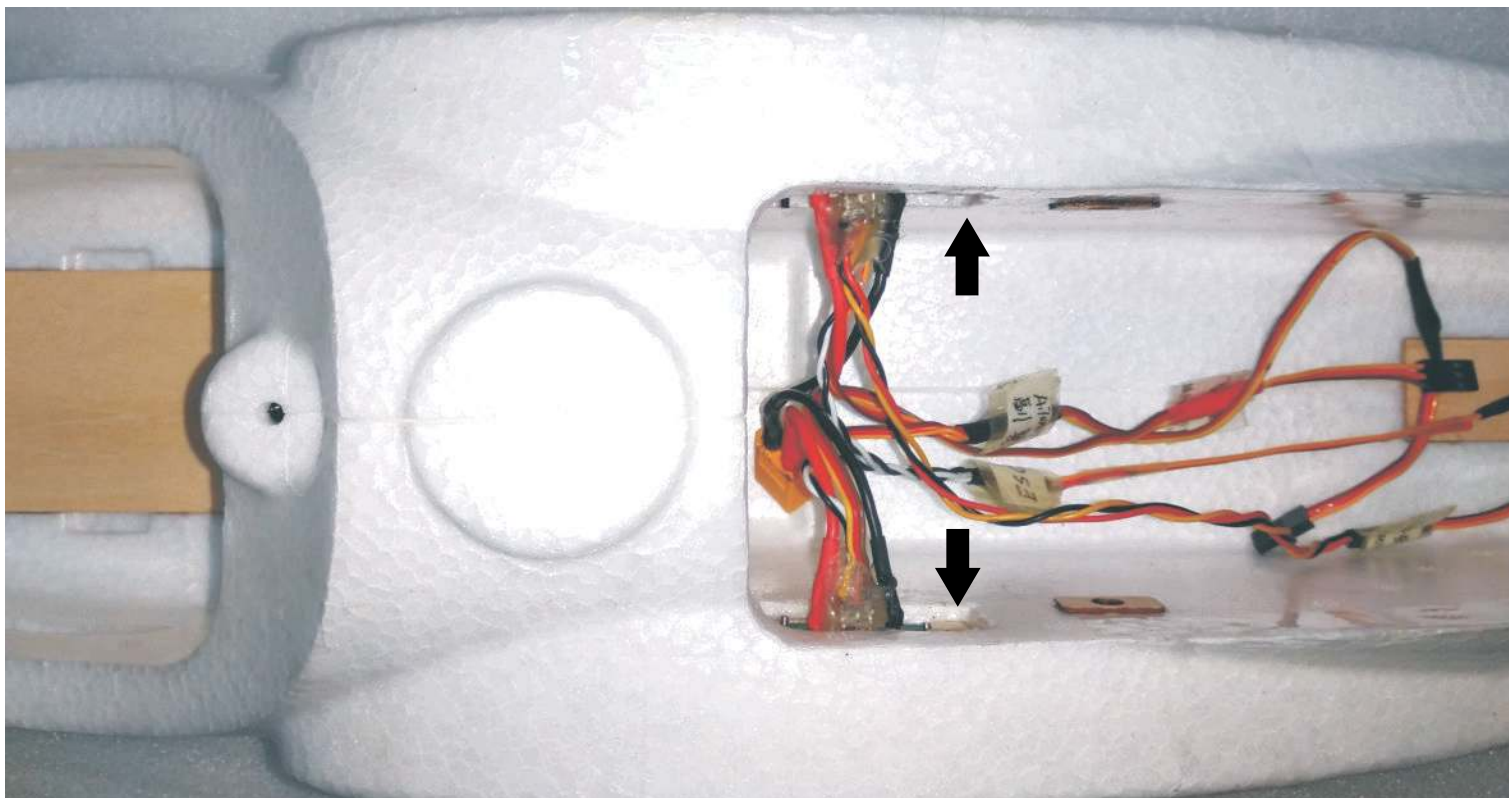

How to install Motors and Propellers

- 1> Propeller running inward
- 2> Left CW Right CCW
- 3> Propeller's Character forward

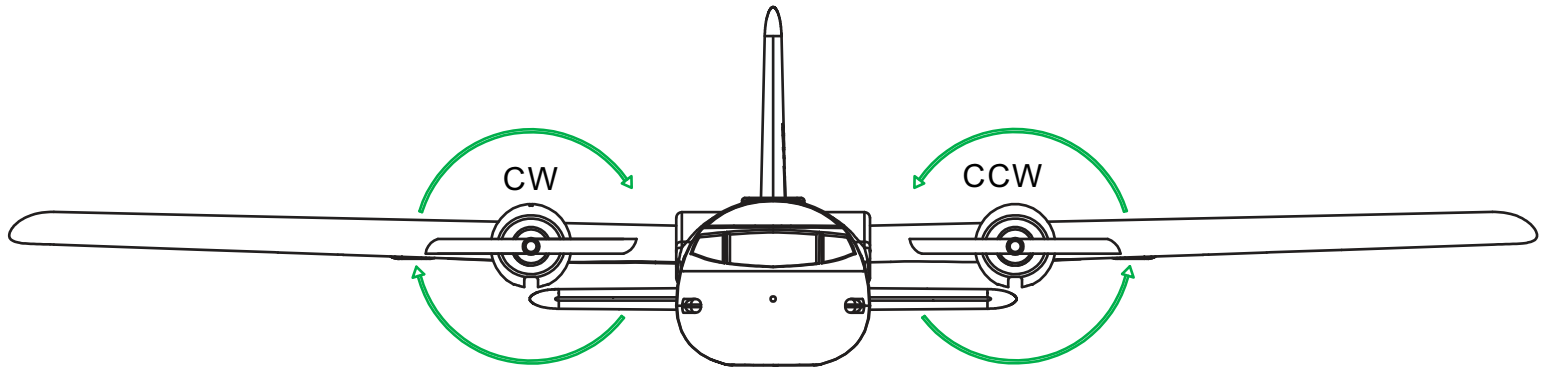

Tie screw like this if you are afraid of missing screws

