

BIXE



INSTRUCTION MANUAL



**PLEASE READ THIS MANUAL CAREFULLY AND
FOLLOW THE INSTRUCTION**

Thank you for choosing this classic model airplane.
This model is for beginner, intermediate and experi-
enced hobby enthusiast. Hope you have a nice time
with this wonderful model!!! Happy flying !

Disclaimer: *Do not fly this Airplane at full-throttle for long
periods of time, recommended 20-25 seconds burst!*

TABLE OF CONTENTS

1. Bi x 3 Specifications	2
2. Safety Instructions	2
3. Assembly Instructions	3
4. In the box	3
5. Assembly	4
6. Center of Gravity (CG)	5
7. Charging the Li-Po Battery	6
8. Control direction test	7
9. Trouble shooting	8
10. Accessories	9

BIX3 SPECIFICATION

Design Features:

1. Durable crash resistant molded EPO airframe
2. Ultra stable flight performance
3. Includes optional canopy for FPV equipment
4. Easy assembly
5. Optional wing flaps

Specs:

Wingspan: 1550mm (61 inch)
 Length: 948mm (37.3 inch)
 Weight: 890g
 ESC: 20A
 Servo: 9g x 4 (2 flap servos optional)
 Radio: 6-channel
 Motor: 2630 KV1400 Brushless motor
 Battery: Li-po 11.1v 1800-2200 mAh, 15C

SAFETY INSTRUCTIONS

1. Do not fly in storms, strong winds, bad weather or lightning.
2. NEVER FLY NEAR POWERLINES, overhead wires, roads, railroads or airports.
3. Never fly near houses or people! Your BIX3 can cause damage to property or injury!
4. Do not fly where other models on the same frequency are flying, until you do a preflight check of all your controls.
5. Make sure you do a preflight check- inspect the whole plane and make sure the motor runs smoothly and all your controls work properly. Do this before EACH FLIGHT!
6. Use only genuine Hobby King replacement parts.
7. Don't try to catch the BIX3 during flight- you could be badly injured! Take off from and land on a suitable landing strip.
8. Not recommended for children under 12 years old. Children under 14 should operate the model only with a responsible adult.
9. The BIX3 includes small parts (choking hazards) and sharp edges! Assemble and store your plane out of the reach of children.
10. Never install batteries incorrectly- check the polarity (positive and negative) before connecting or installing batteries.
11. Keep your BIX3 out of direct sunlight (unless you're flying it!) and away from heat sources. Foam can distort when it is overheated.
12. Fly intelligently-don't fly towards yourself or other people, or structures, cars, trees, animals, or anything else on the ground.

First Flight preparation

- Remove and inspect contents.
- Read this instruction manual thoroughly.
- Install the flight battery in the aircraft (Once it has been fully charged).
- Ensure pushrods move freely.
- Perform the Control Direction Test with the transmitter
- Find a safe and open area
- Plan flight for flying field conditions
- Adjust battery for center of gravity(CG)
- Perform a radio system Range Check
- Adjust flight controls and transmitter
- Find a safe and open area
- Plan flight for flying field conditions

Maintenance After Flying

- Disconnect flight battery from ESC (Required for Safety)
- Turn off transmitter
- Remove flight battery from aircraft
- Recharge flight battery
- Repair or replace all damaged parts
- Store flight battery apart from aircraft and monitor the battery charge
- Make note of flight conditions and flight plan results, planning for future flights

ASSEMBLY INSTRUCTIONS

This manual provides simple step by step assembly instructions. However, if this is your first plane, we recommend that you ask a fellow flier for some help putting your BIX3 together. They will probably jump at the chance just to get a look at it!

WHAT'S IN THE BOX

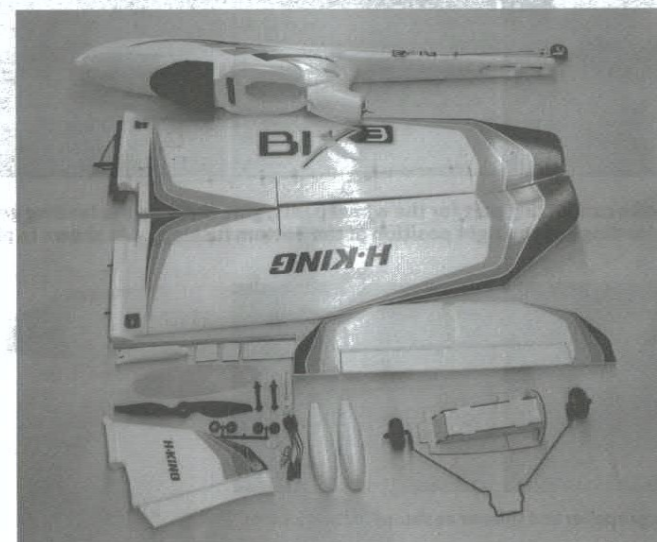

ASSEMBLY

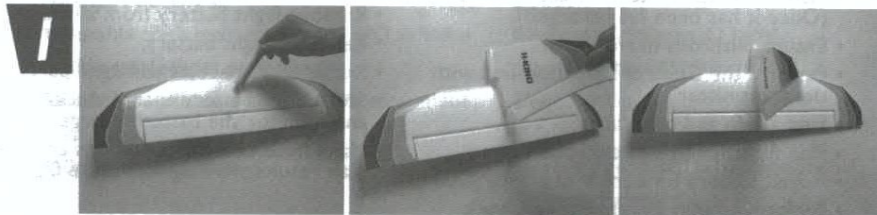

1 Add glue on the connecting part for vertical wing. Wait for a while, paste the vertical wing to the horizontal wing.



2 Add glue as shown in picture, wait for a while, put the vertical wing and horizontal wing onto the right position of the fuselage.

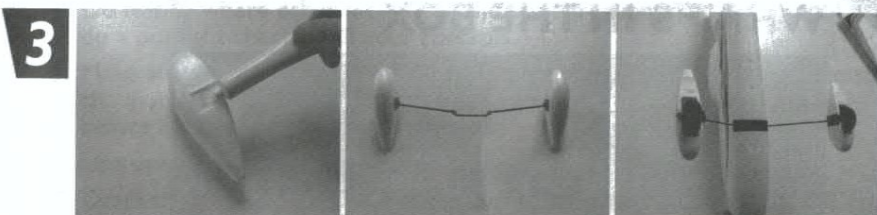

3 Add glue on the connecting part for the wheel pants, glue them on the landing gear and put the landing gear on right position of the bottom fuselage. (As shown in pictures)



4 Assemble the propeller and spinner as shown in the pictures.

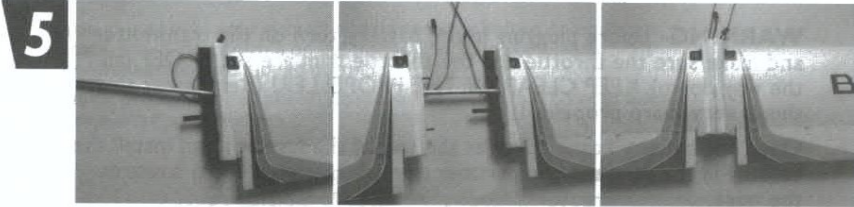

5 Insert the metal tube into the left and right wings, connect the left wing and right wing together.

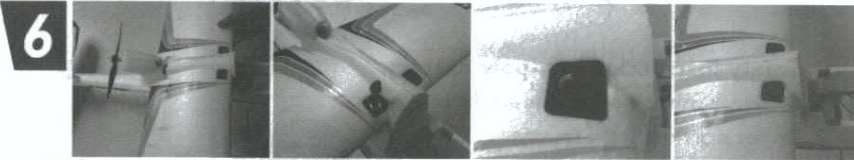

6 Put the wings on the connecting part for the fuselage, use wing bolts to fasten the main wings. (As shown in pictures)



7 Plug the wires into the receiver, connecting them to the appropriate places. (please see the instructions on the receiver)

8 Connect the XT-60 connectors of the ESC and battery. Fasten the battery in the right place. Close the battery hatch.

CENTER OF GRAVITY (CG)

9 Assembly finished.

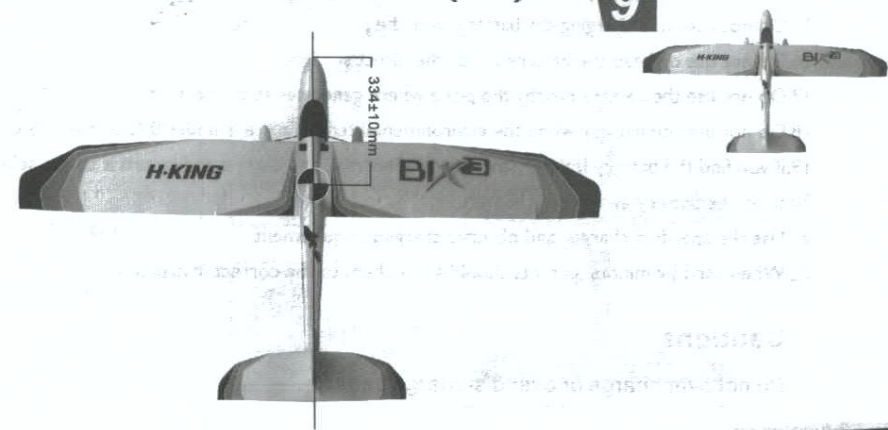

CHARGING THE LIPO BATTERY

WARNING- Before plugging in the battery, turn on the transmitter and make sure the throttle and the throttle trim are set to OFF (all the way down). **KEEP CLEAR OF THE PROPELLER!** (Remember that this is very sharp propeller!)

Open the battery hatch cover at the top of the fuselage and install the battery in the forward compartment, which is angled down towards the nose.

Install the battery first, and then plug it in. Make sure that no wires are out of place, and close the battery hatch.

Safety Instruction of li-poly battery

1. Do not disassemble or reconstruct the battery.
2. Do not short-circuit the battery.
3. Do not use or leave the battery nearby the fire, stove or heated place (more than 80 °C)
4. Do not immerse the battery in water or sea water, do not get it wet.
5. Do not charge the battery in direct sunlight.
6. Do not impact or toss the battery.
7. Do not use the battery with conspicuous damage or deformation.
8. Do not attempt direct soldering on the battery.
9. Do not reverse charge or over discharge the battery.
10. Do not reverse charge or reverse connect.
11. Do not connect the battery to the ordinary charger socket or car cigarette jack.
12. Do not use the battery for unspecified equipment.
13. Do not touch the leaking battery directly, please wash your skin or clothes with water.
14. Do not mix the Li-Poly battery with other dis-charged battery in using.
15. Do not continue charging the battery over the prescribed time.
16. Do not use or keep the battery under the direct sunlight.
17. Do not use the battery nearby the place where generates static electricity.
18. Do not use the battery when the environmental temperature is under 0 °C or over 45 °C
19. If you find the battery leaking, smelling or abnormal, stop using it and return it to the seller.
20. Keep the battery away from children.
21. Use the specified charger and observe charging requirement.
22. When used by minors, parents should show them to the correct instruction.

Cautions

Do not over charge or over dis-charge battery.

CONTROL DIRECTION TEST

You should bind your aircraft and transmitter before doing these tests. Move the controls on the transmitter to make sure aircraft control surface are moved correctly.

Note: Make sure tail pushrods move freely and that paint or decals are not adhered to them.

Elevator

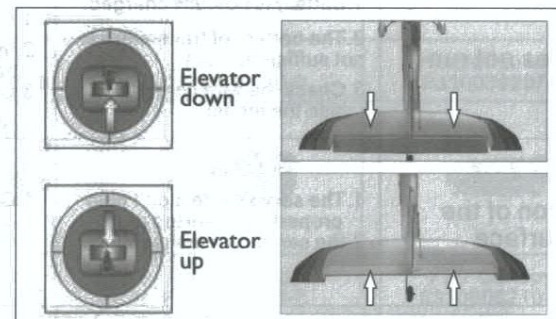

Aileron

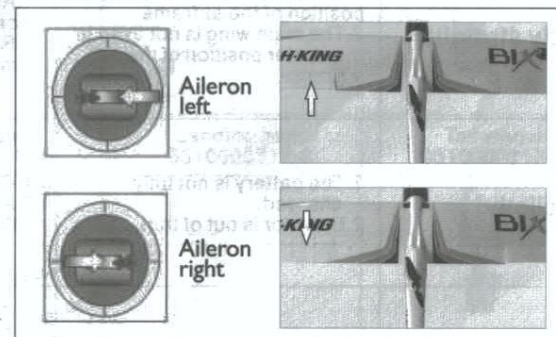



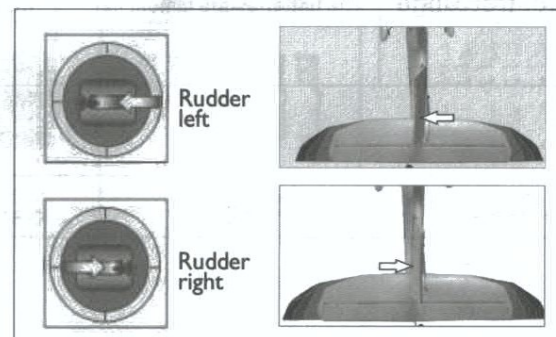











Rudder



TROUBLE SHOOTING

Problem	Cause	Solution
Motor does not run	<ol style="list-style-type: none"> 1. Battery is not fully charged. 2. The battery of transmitter is not sufficient 3. Check the wire connection inside the model 	<ol style="list-style-type: none"> 1. Charge the batteries. 2. Install a full charged battery 3. Contact the local dealer
No reaction of the control surface	<ol style="list-style-type: none"> 1. The servo cable didn't plug properly or inverted plug. 2. the servo is damaged 	<ol style="list-style-type: none"> 1. Check the connection of the servo cable 2. Change another servo.
Can not fly straight	<ol style="list-style-type: none"> 1. The rudder is not in the center position of the airframe 2. The main wing is not fixed in the center position of the airframe. 	<ol style="list-style-type: none"> 1. Adjust the trim switch on the transmitter 2. Re-assembly the main wing
Can not climb	<ol style="list-style-type: none"> 1. The battery is not fully charged. 2. Elevator is out of trim. 	<ol style="list-style-type: none"> 1. Charge the battery 2. Adjust the trim on the Transmitter.
Limited control range	The batteries are almost flat	Install new batteries

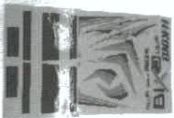
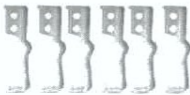
ACCESSORIES

		
Fuselage 9310000205-0	Main wing 9310000206-0	Horizontal wing 9310000207-0
		
Vertical wing 9310000208-0	Sport Canopy 9310000209-0	FPV Canopy 9310000210-0
		
Wheel pants 9310000211-0	Landing gear 9310000212-0	Tail wheel 9310000213-0
		
Brushless motor (2630, KV1400) 9310000215-0	Control wire-steel 9310000216-0	Spinner set 9310000217-0
		
Decal set 9310000218-0	Flap Hinges 310000070	Pin horns 310000061

BIXE

**HobbyKing**
.com

