

CRACK PITTS XL

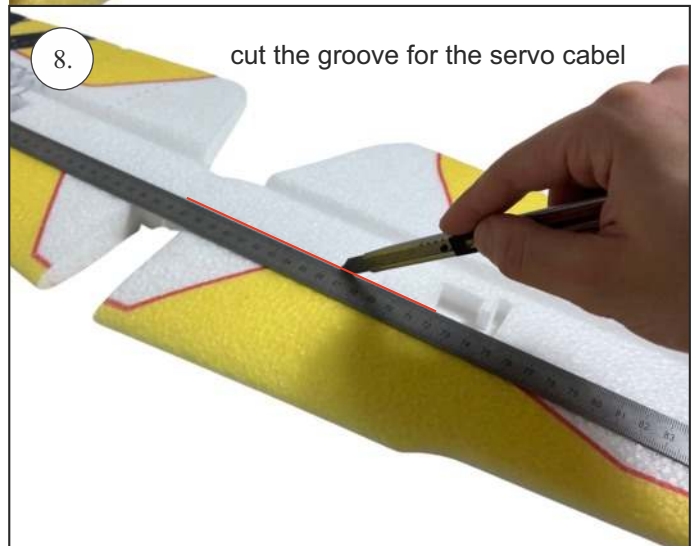

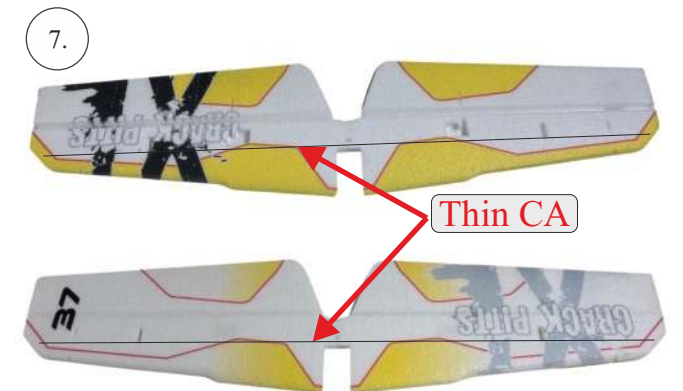

Do the same on the both wings

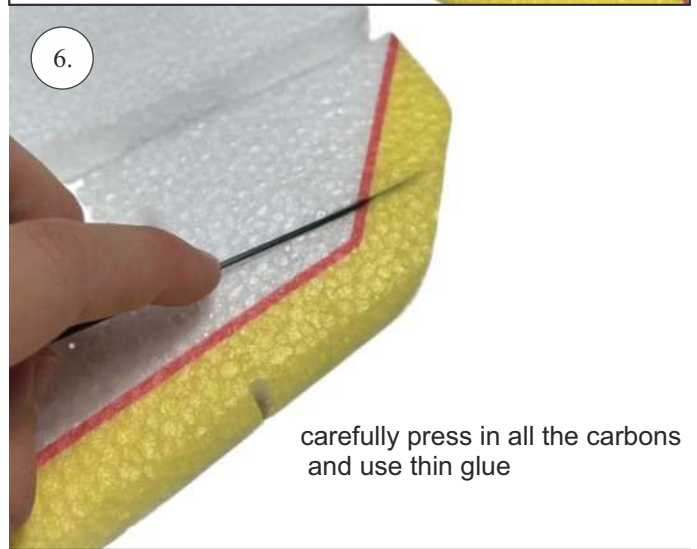
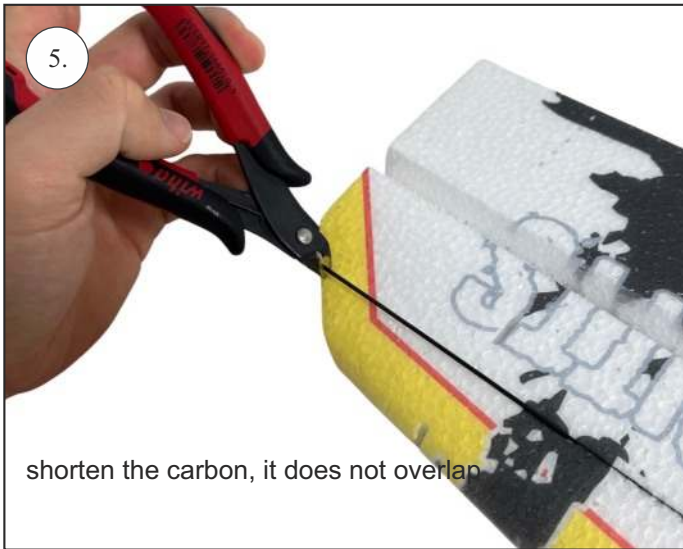
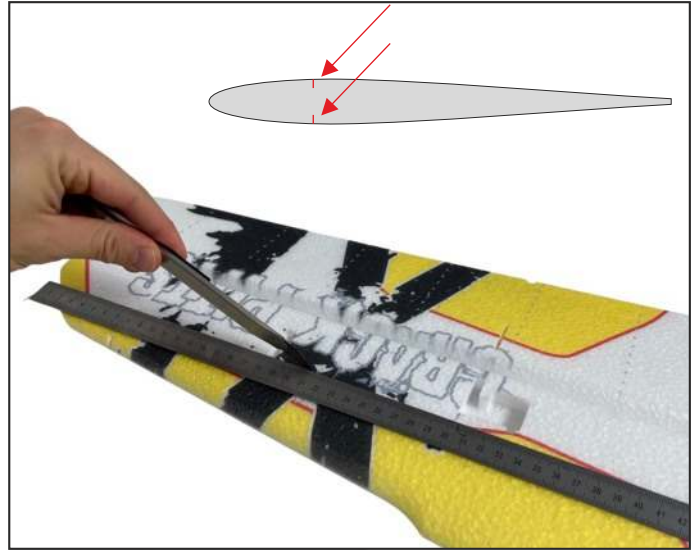
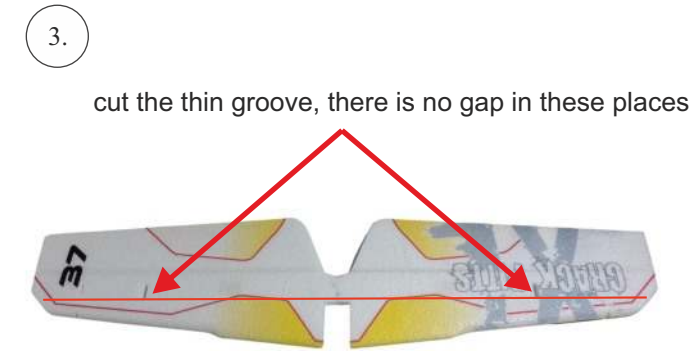
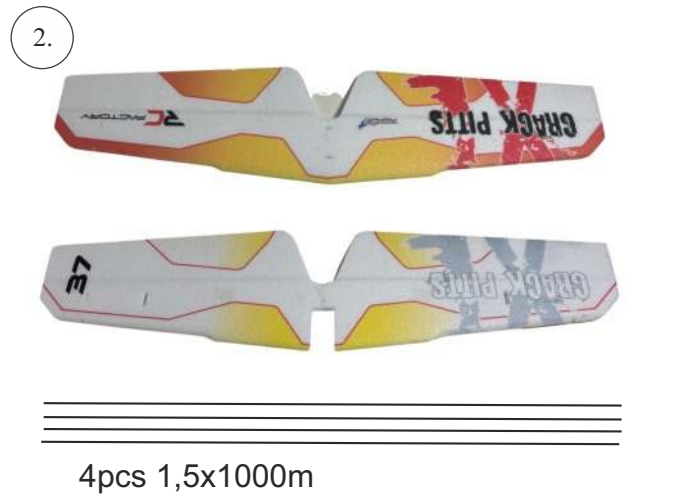
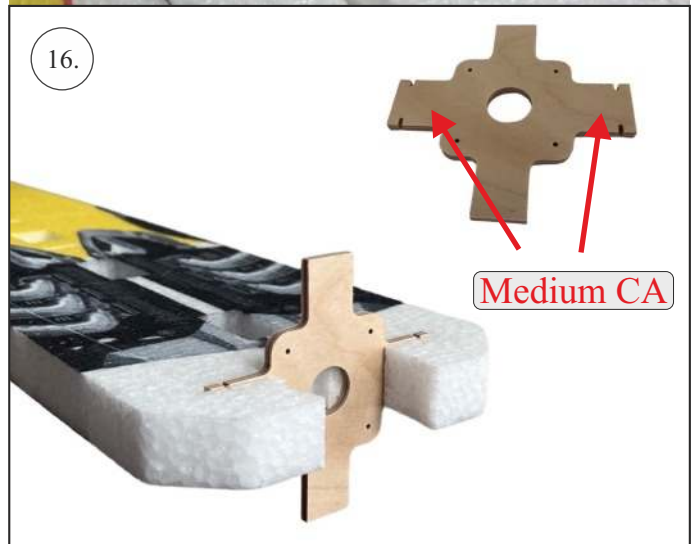
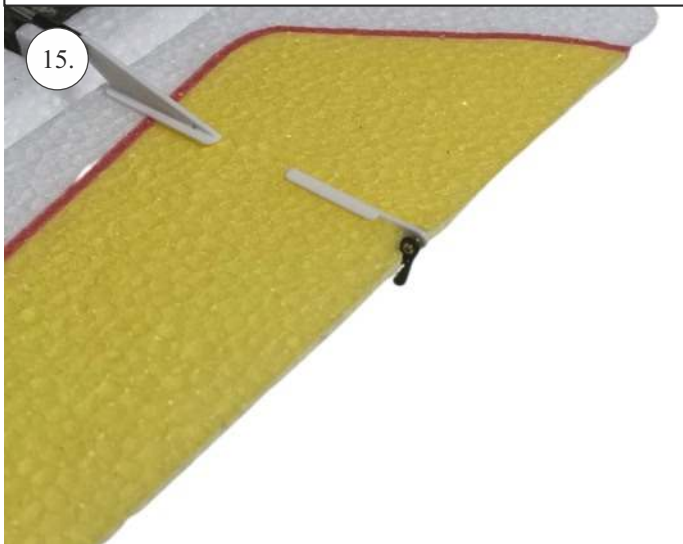
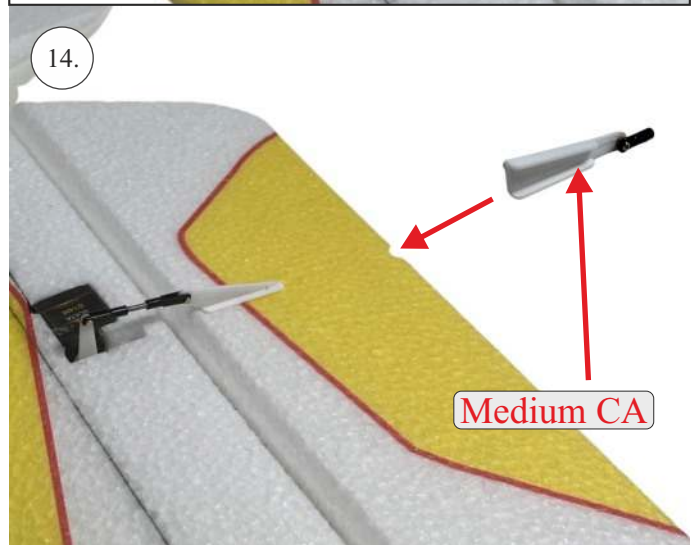
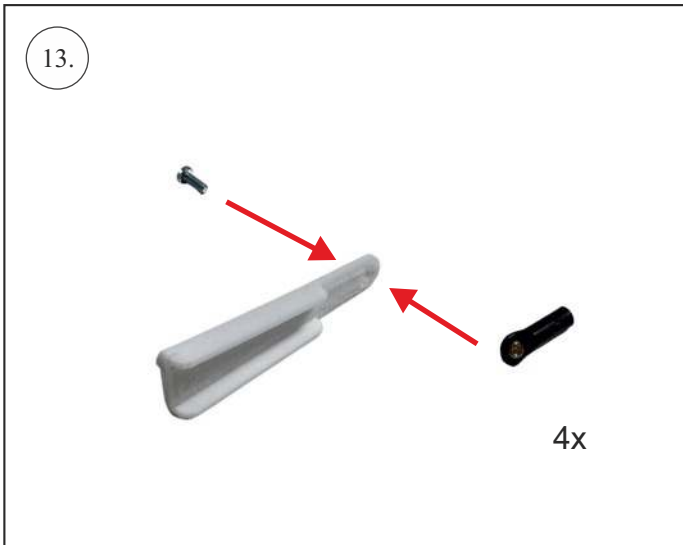
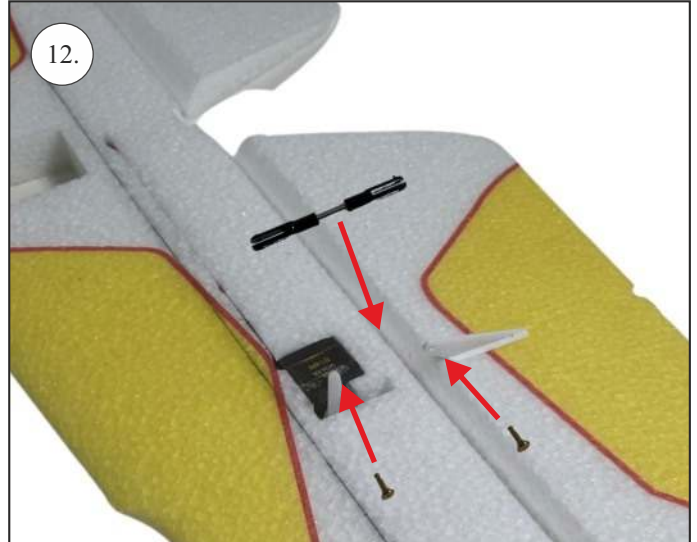
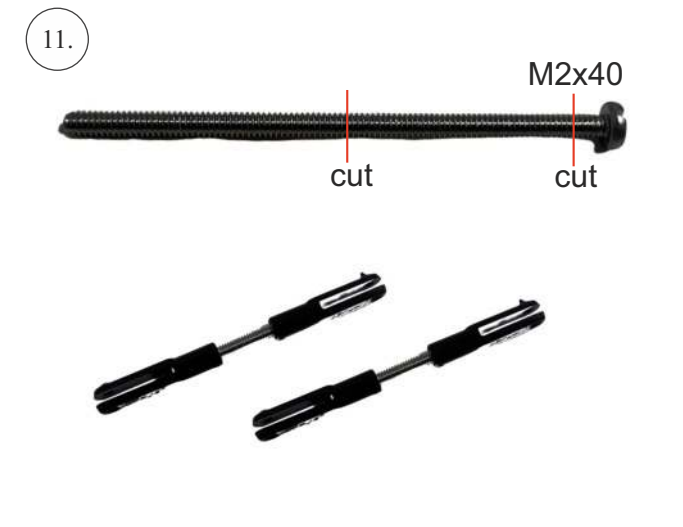

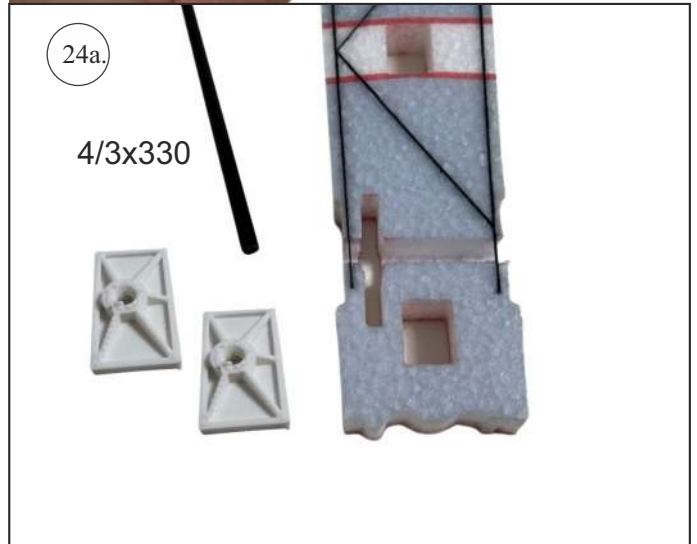
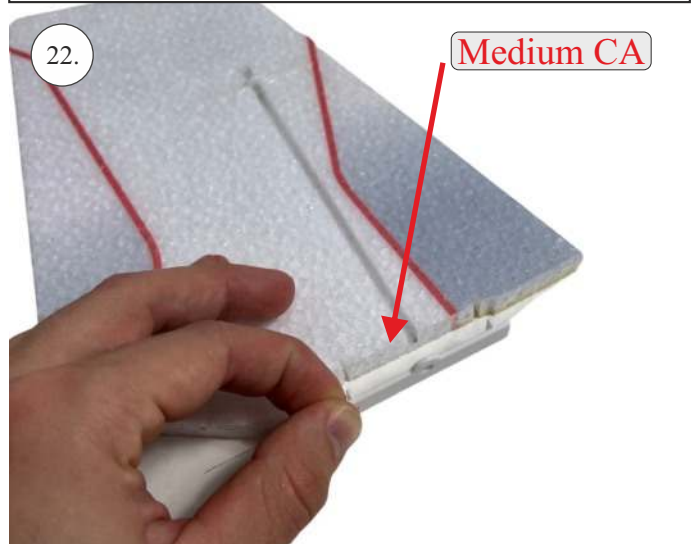
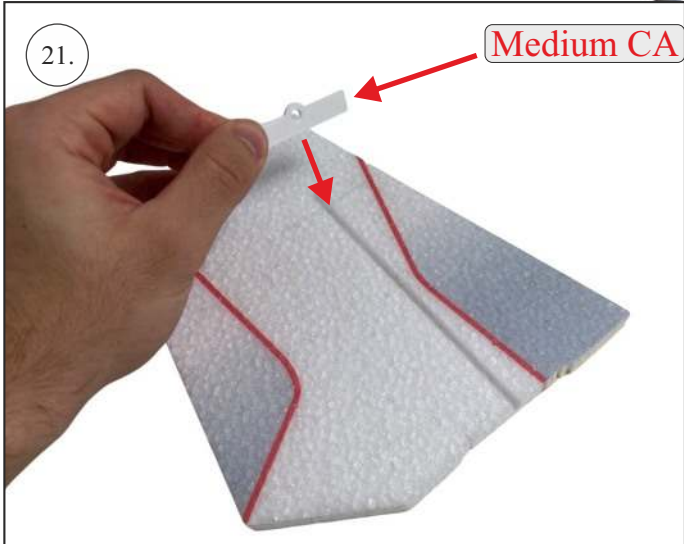
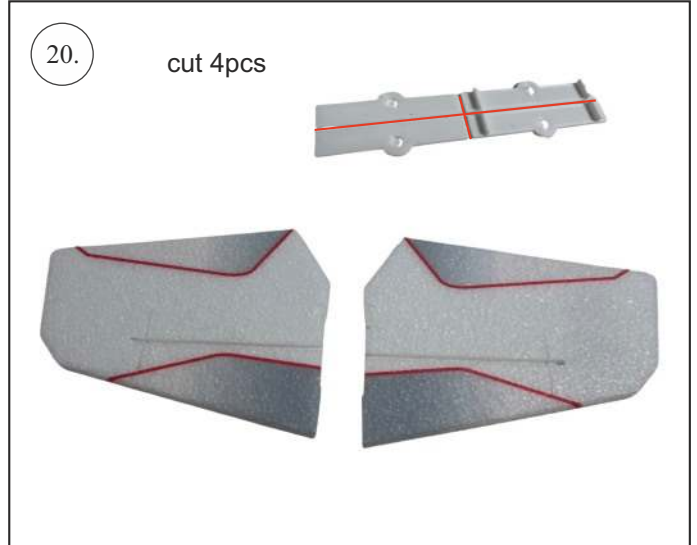
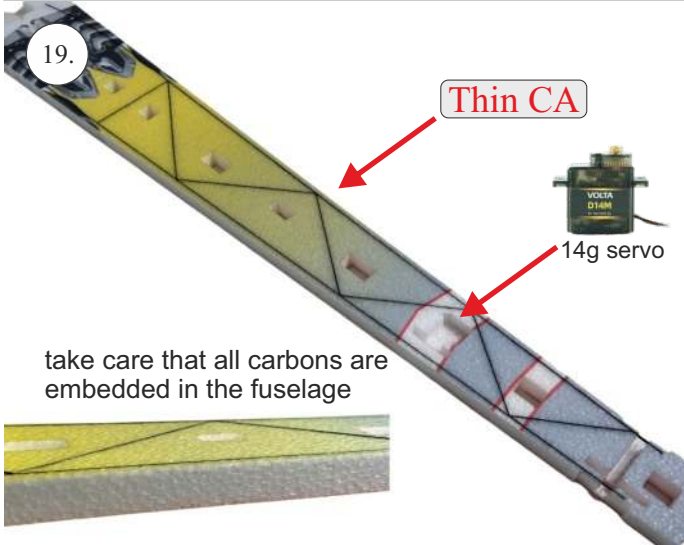
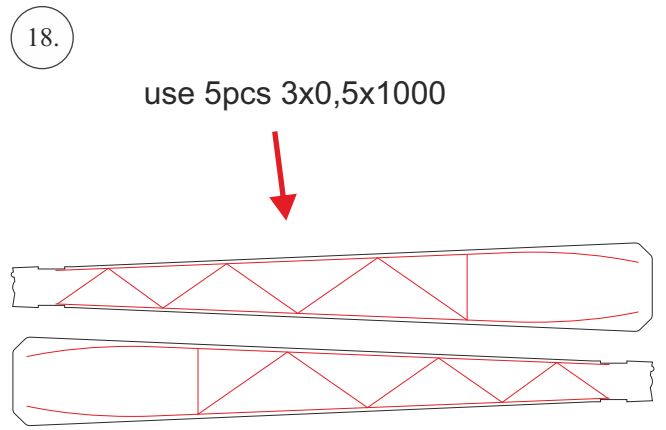
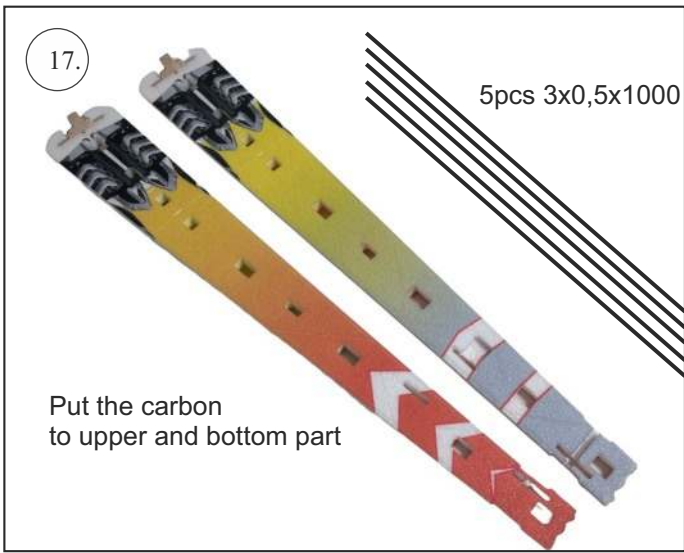

elevators are prepared for the next steps

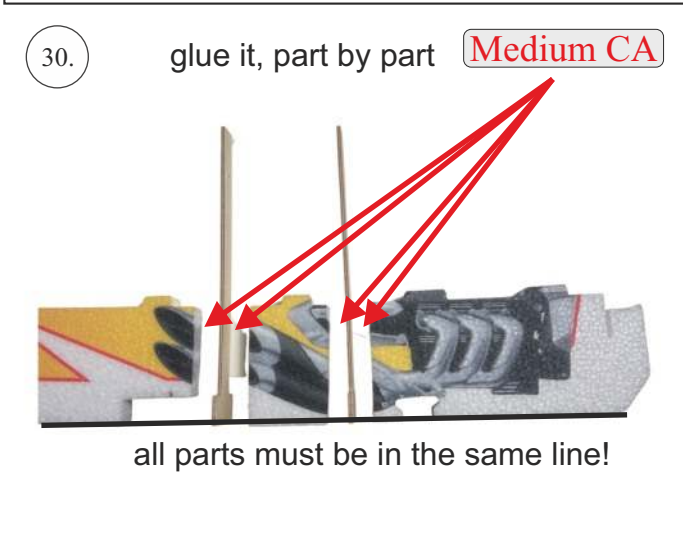
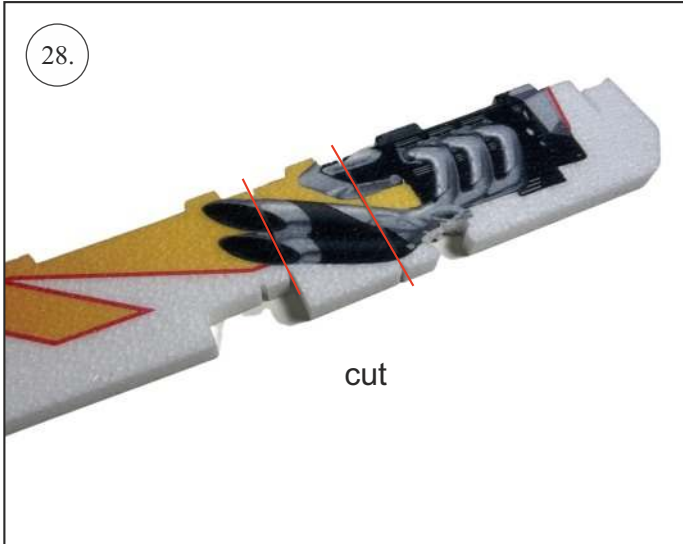
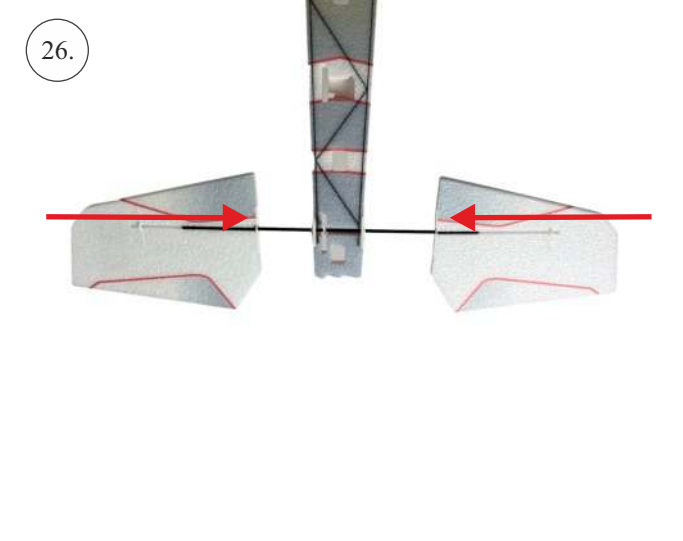
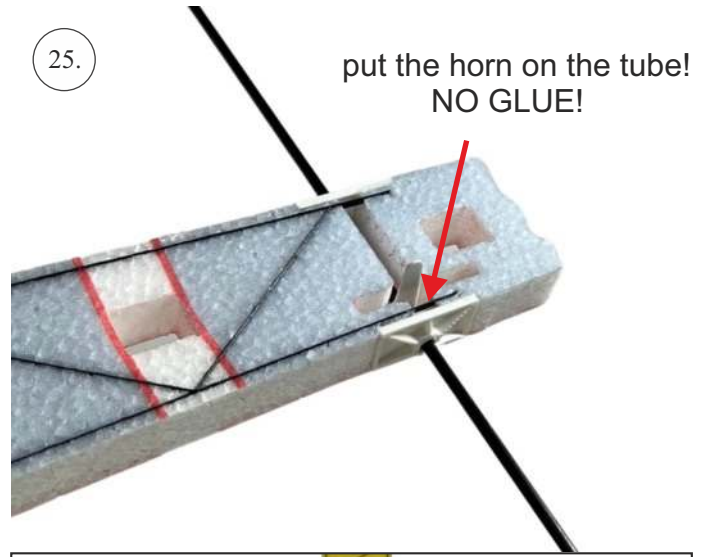
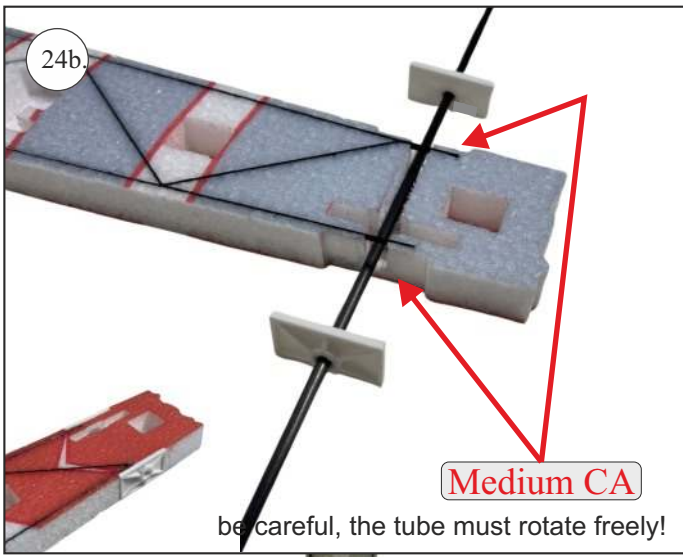

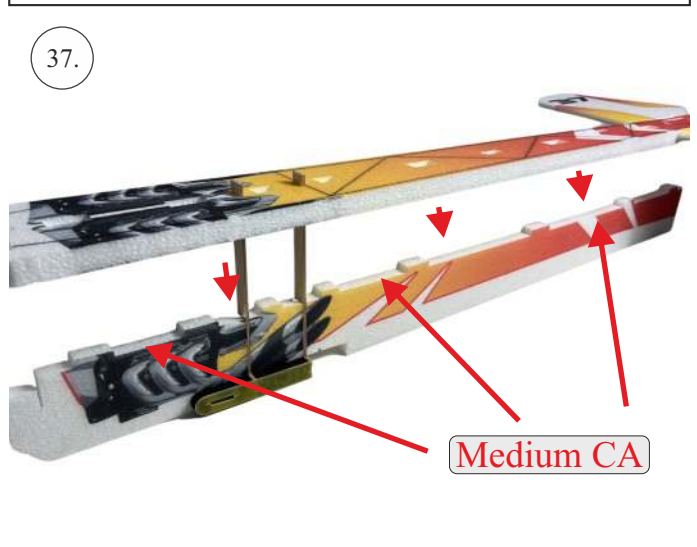
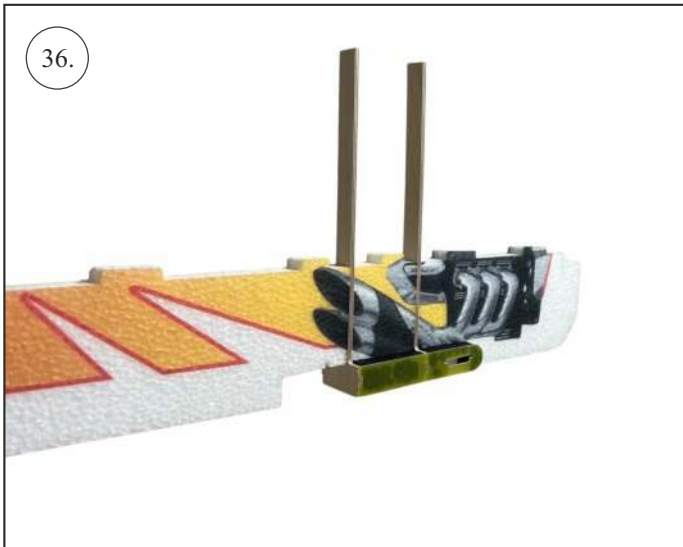
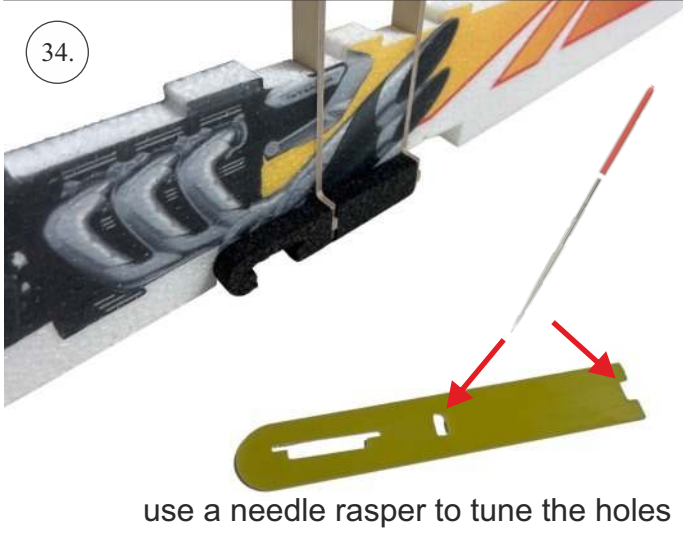
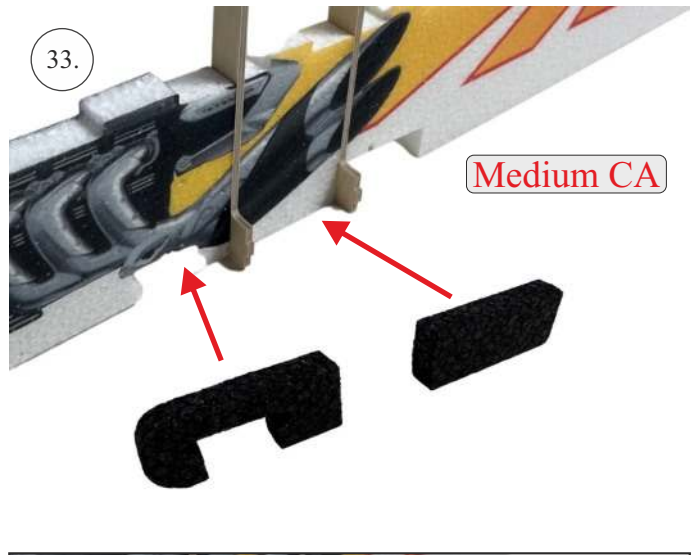
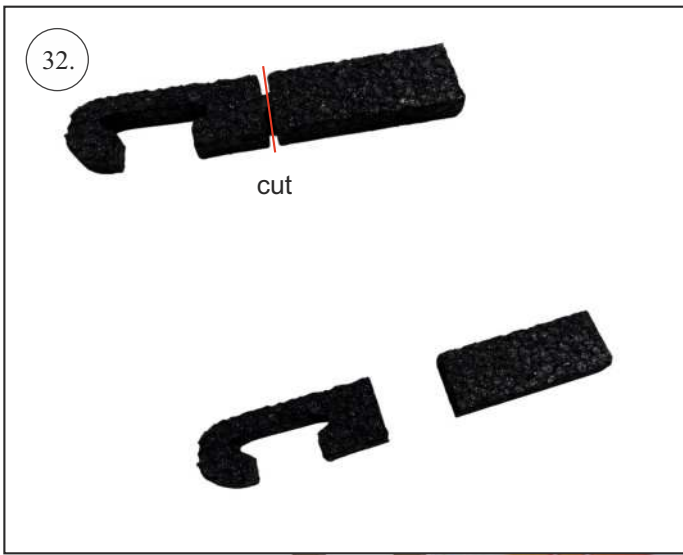

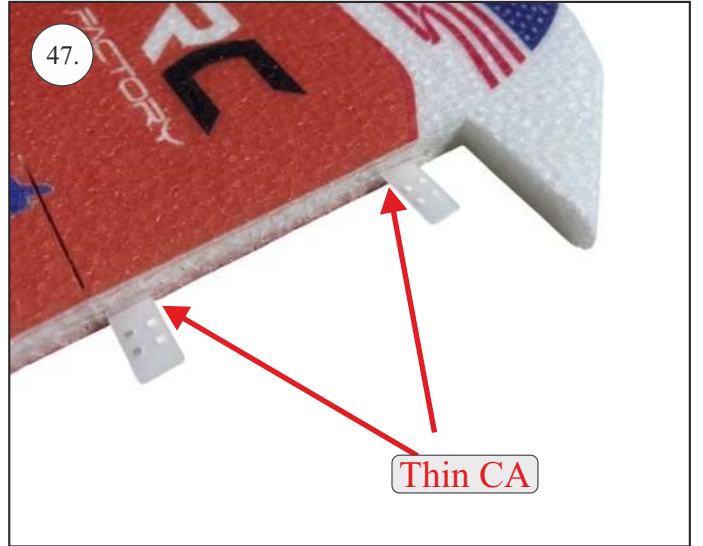
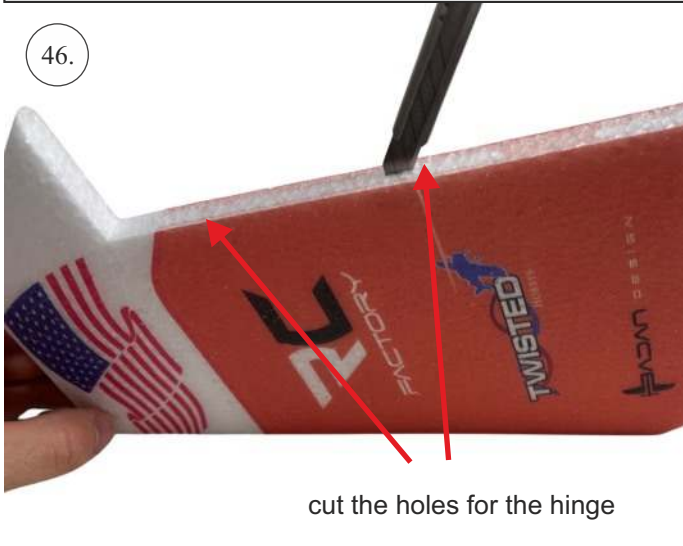
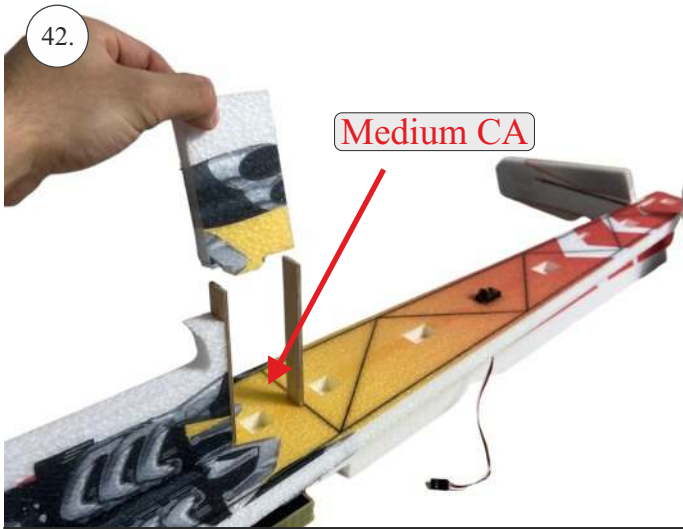
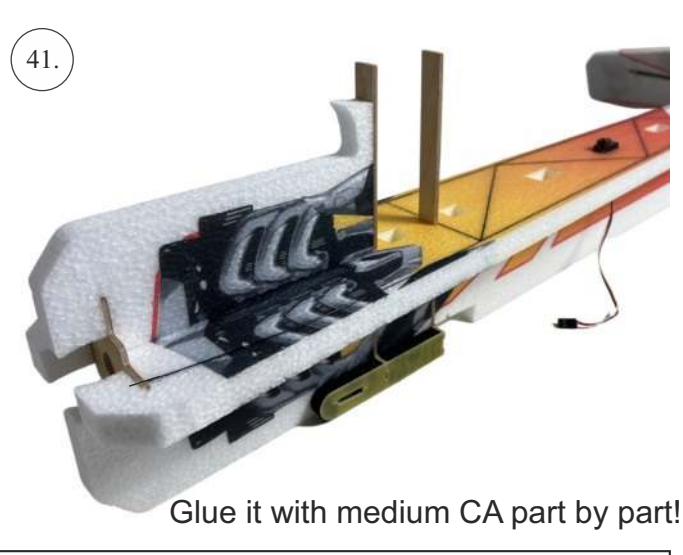
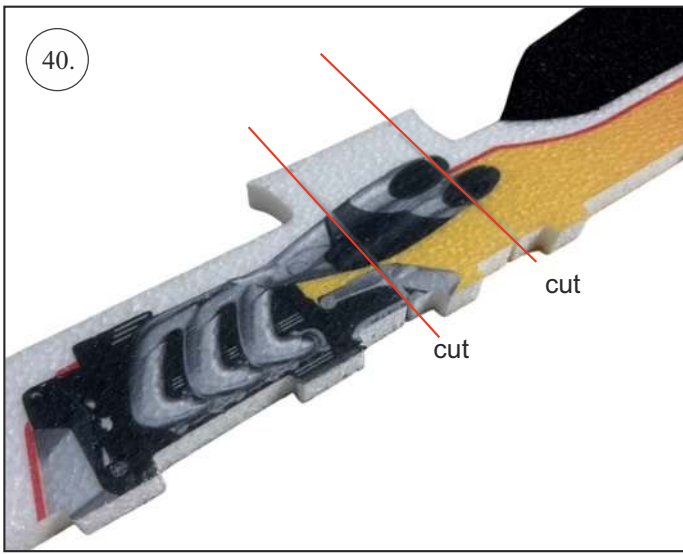

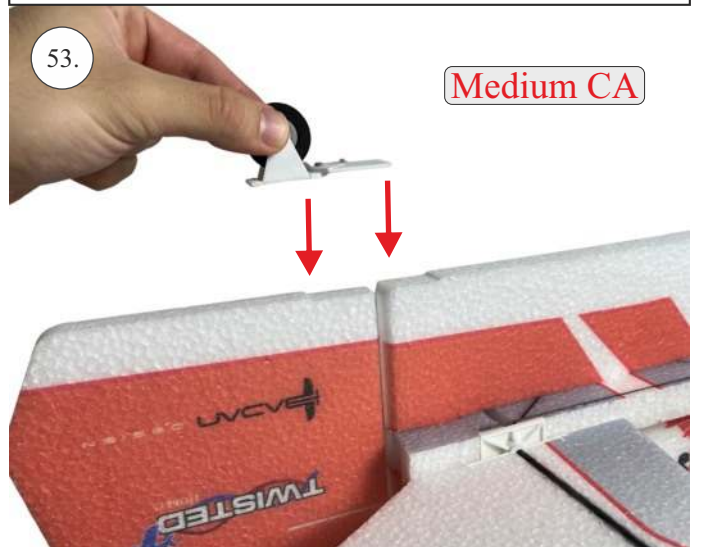
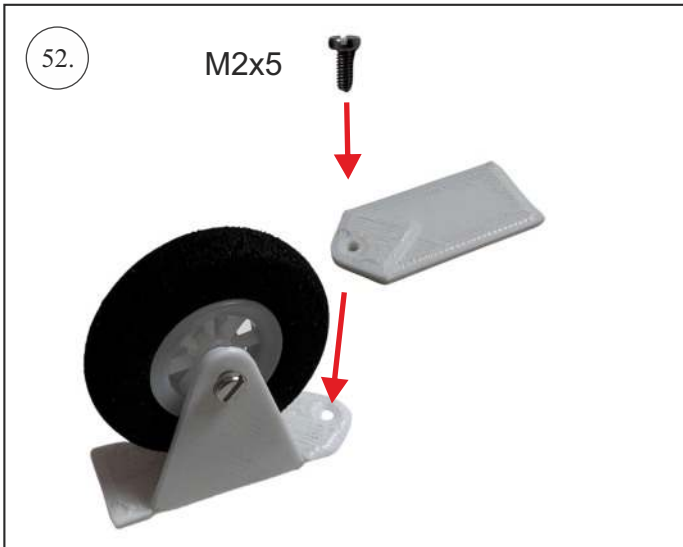
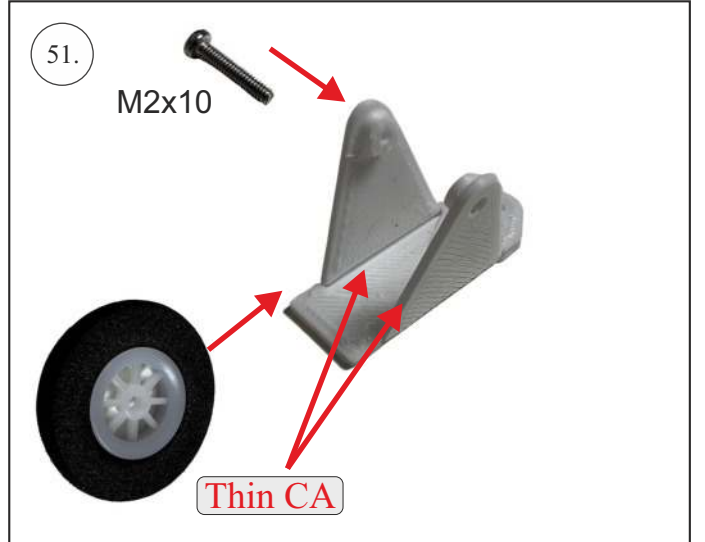
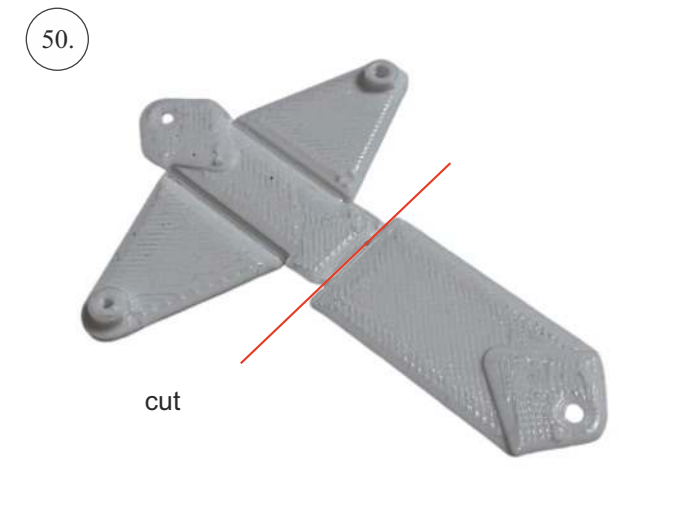
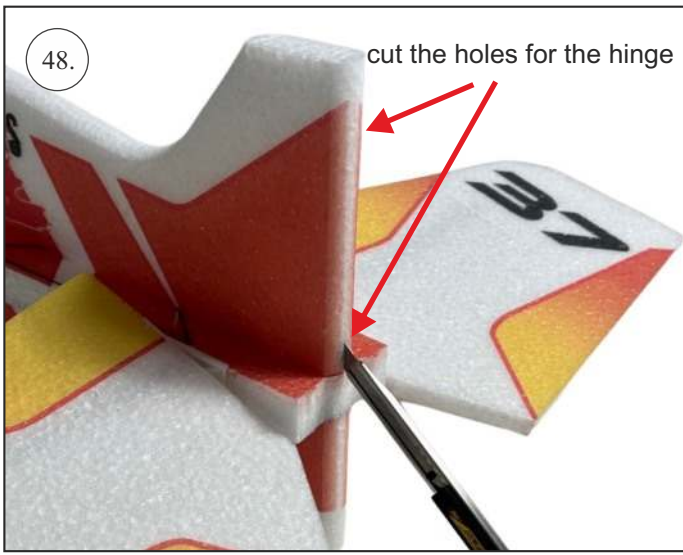

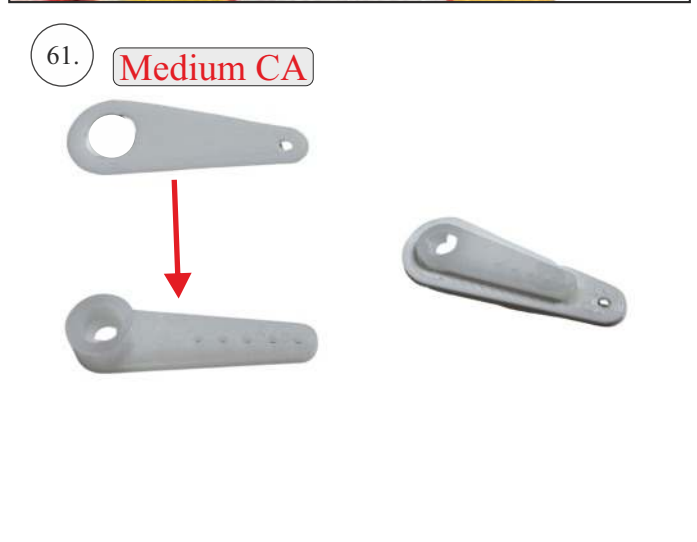
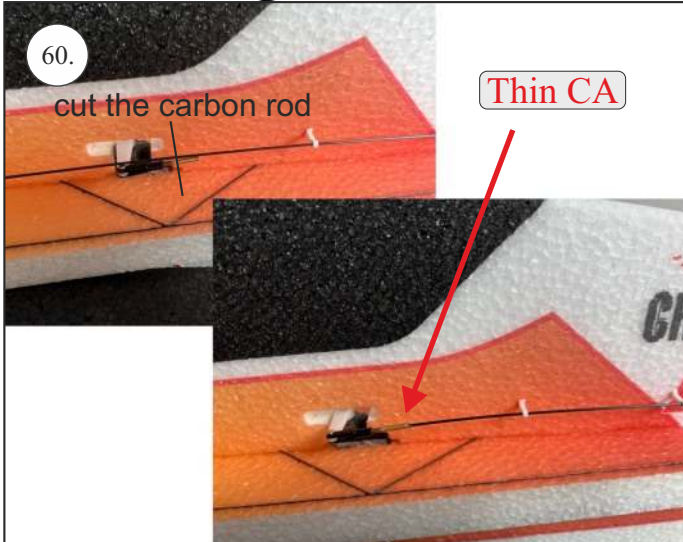
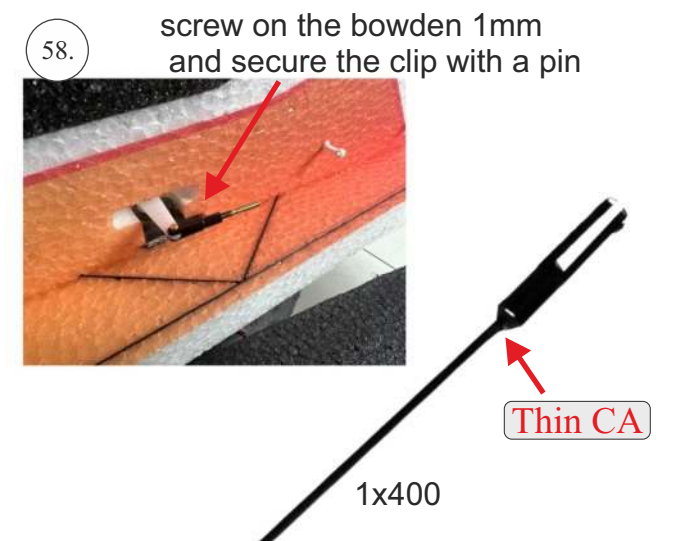
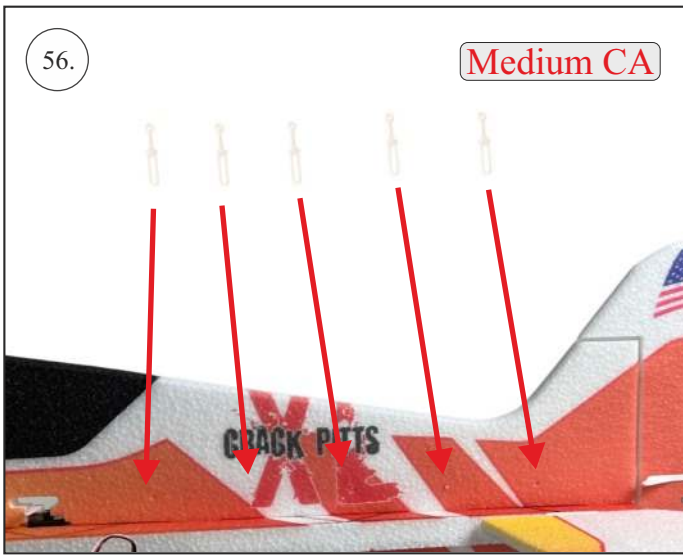

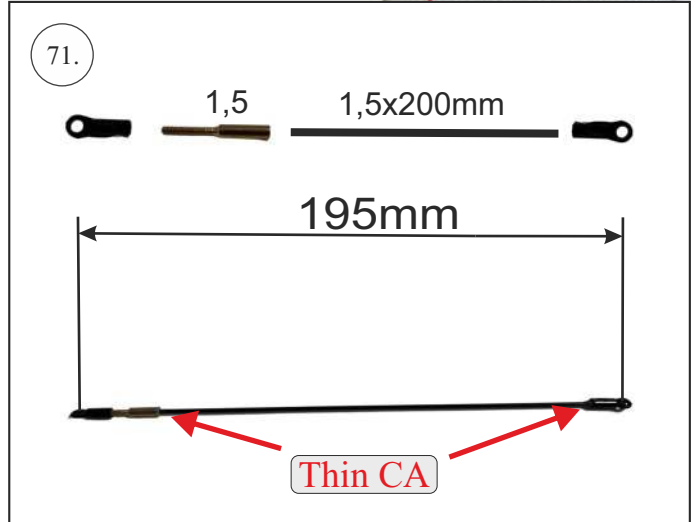
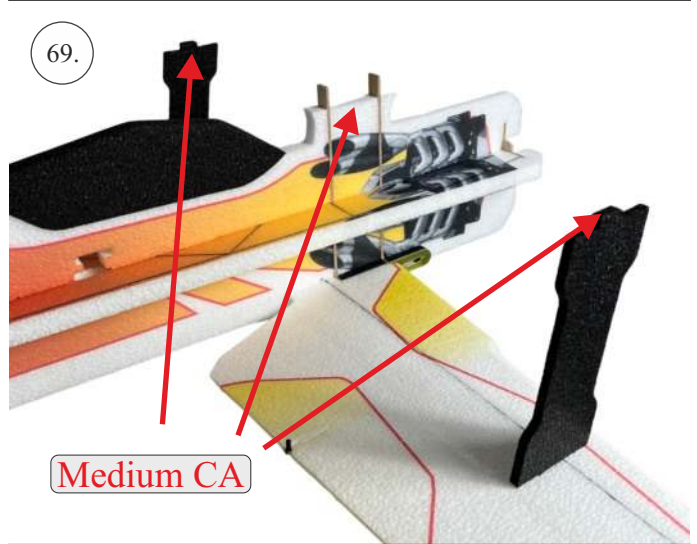
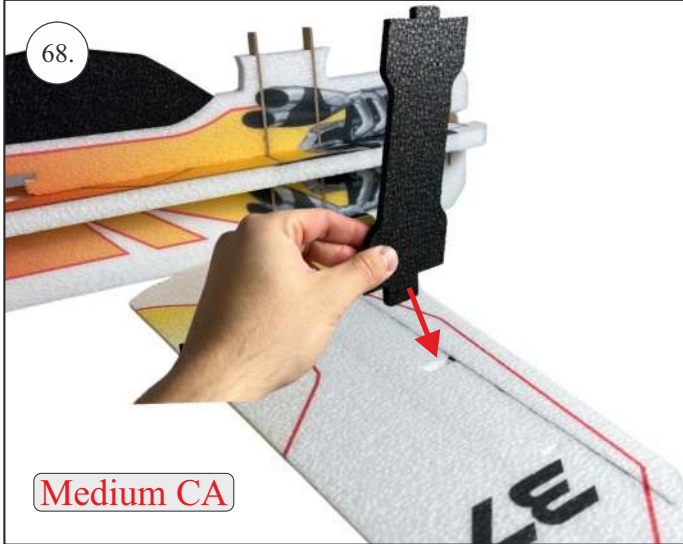
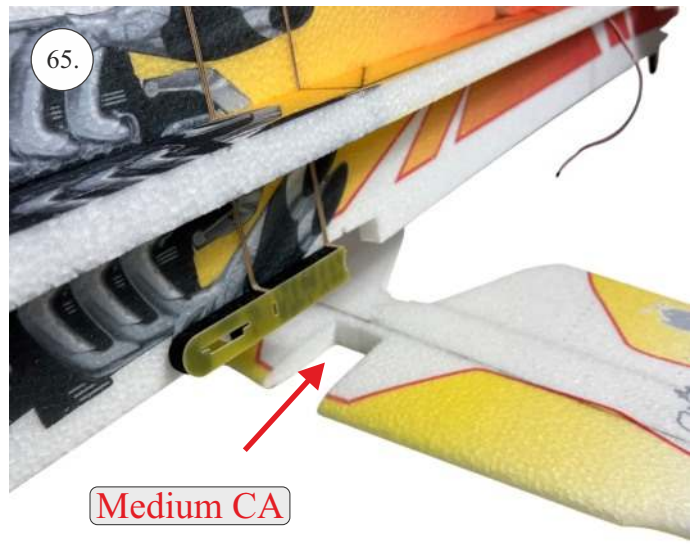
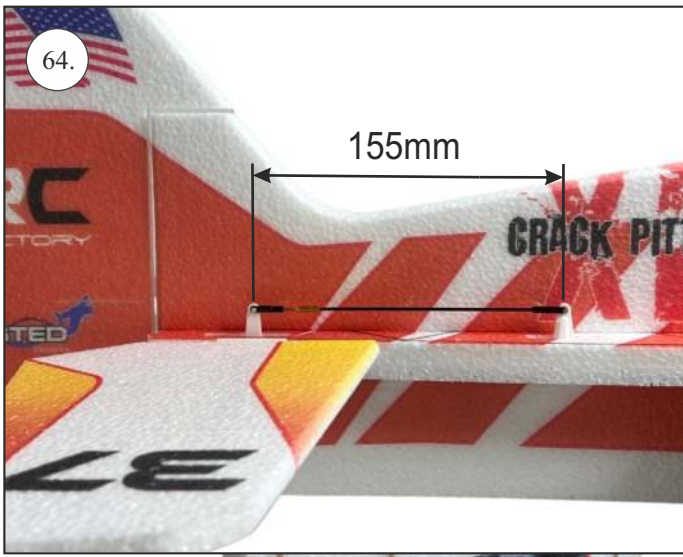

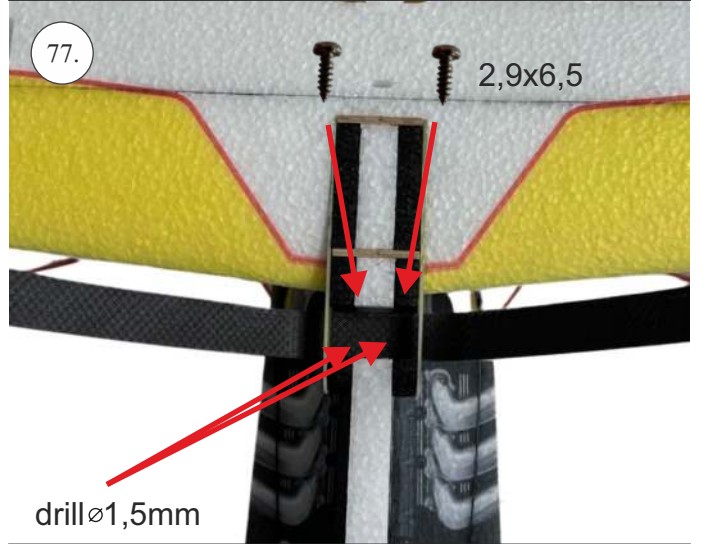
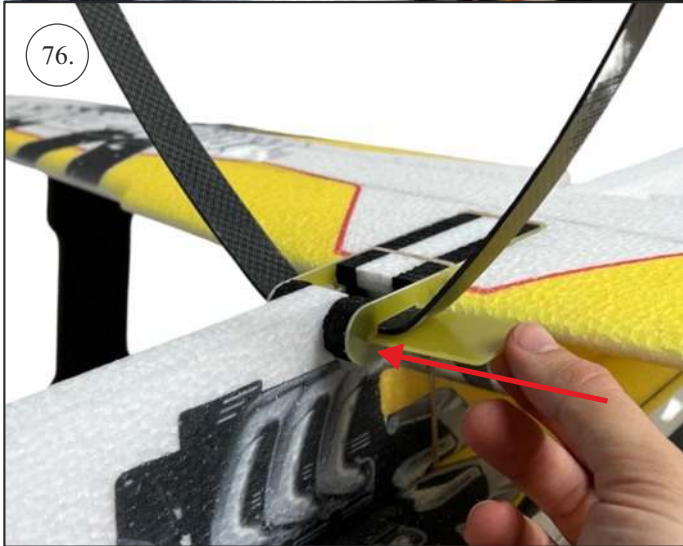
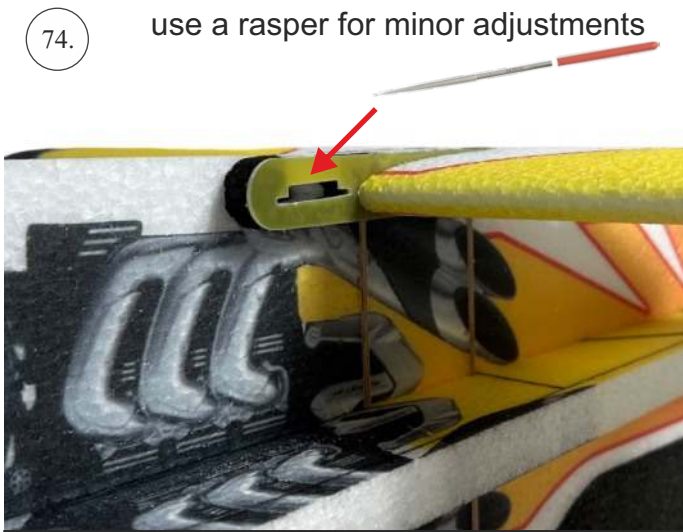
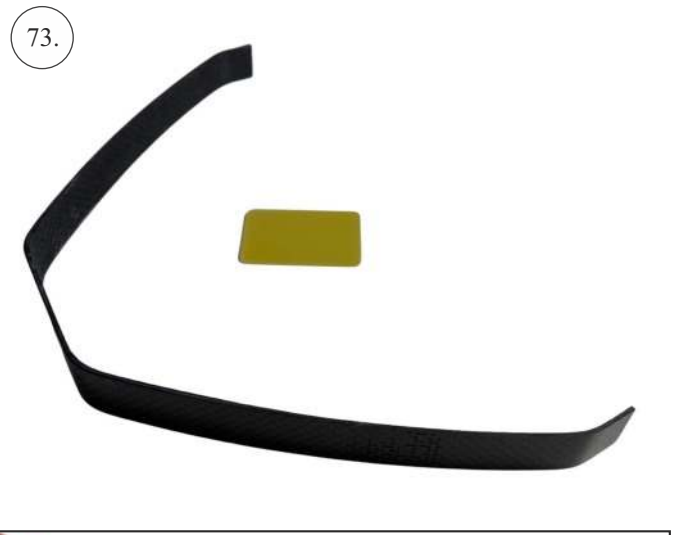
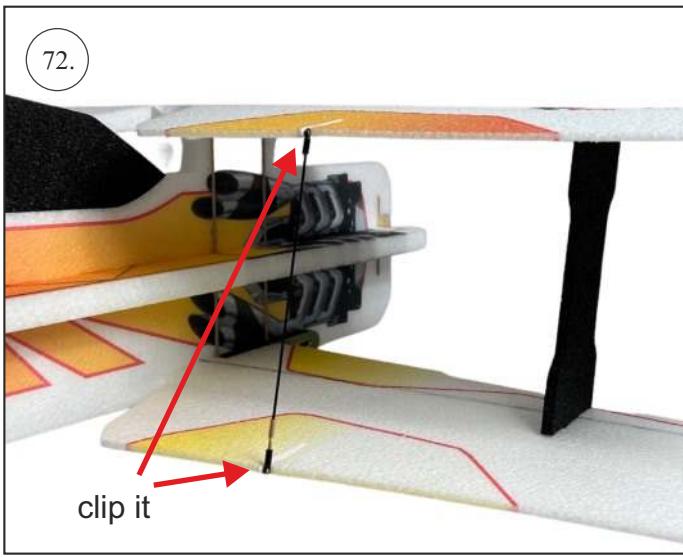

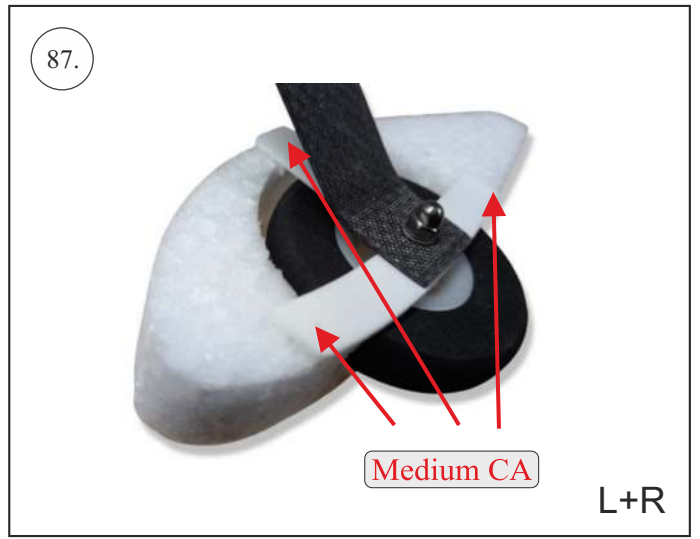
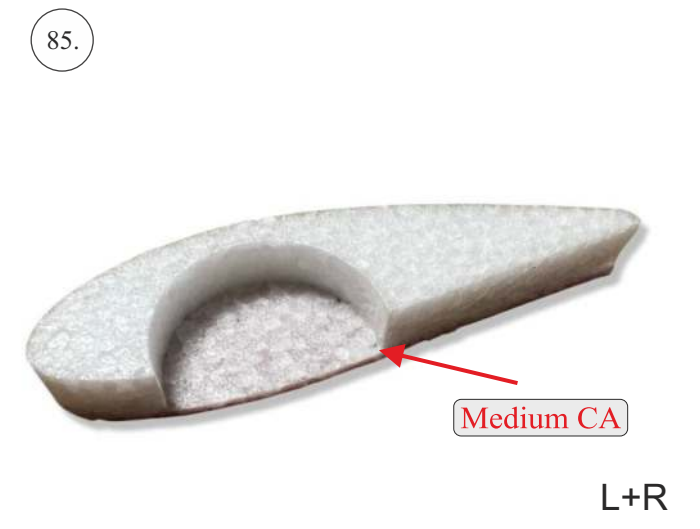
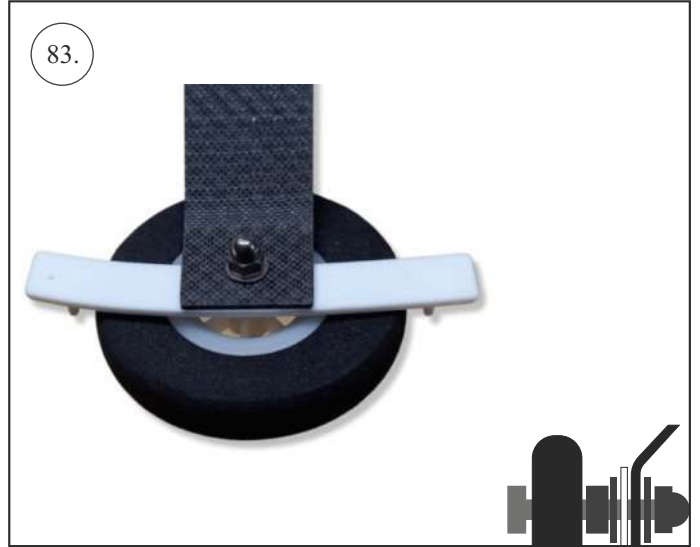
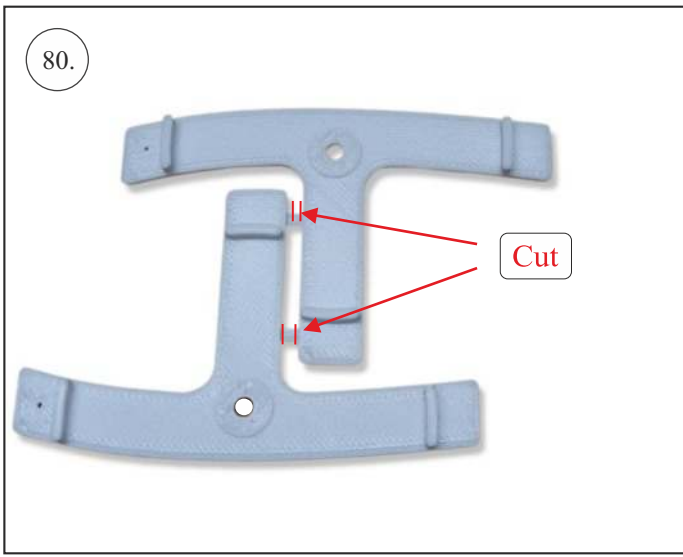

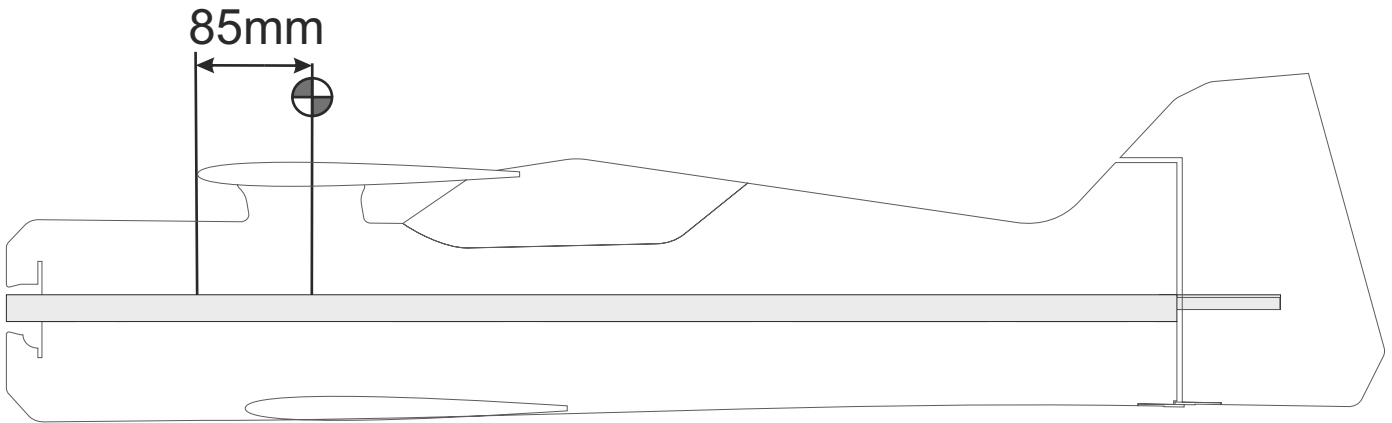

We wish you many happy flying hours with the Crack Pitts XL.

Your RC Factory team