

RADIO CONTROL MODEL

Dago red

4
Unlimited Air Racer

SPECIFICATIONS

Wingspan.....57.5 in. / 146cm
Length.....50 in. / 127cm
Engine.....46 2T / .70 4T
or Electric equivalent
Radio.6-channel- 4 (5) servos

INSTRUCTION MANUAL

Almost ready to fly

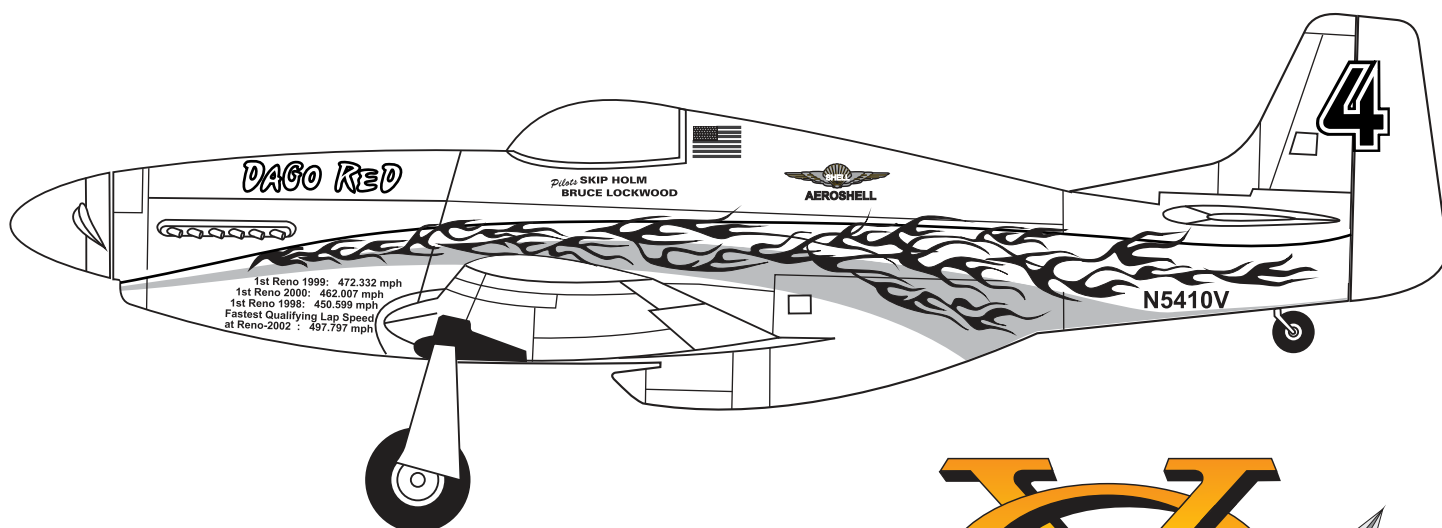

WARNING! This radio control model is not a toy. If modified or flown carelessly it could go out of control and cause serious bodily injury or property damage.
Before flying your airplane, ensure the air field is spacious enough.
Always fly it outdoors in safe areas with no debris or obstacles.

REQUIRED FOR OPERATION (Purchase separately)

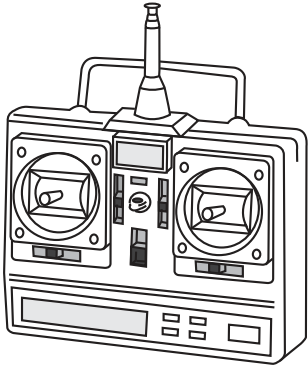

10.5x6 for .40 - 2 cycle engine
 11x6 for .46 - 2 cycle engine
 12x6 for .60 - 4 cycle engine
 12x7 for .70 - 4 cycle engine
 13x8 for G-46 HP Motor.

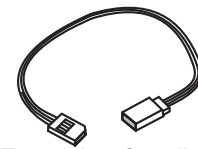

Extension for aileron servo, retract servo.

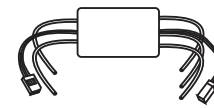

Motor Control

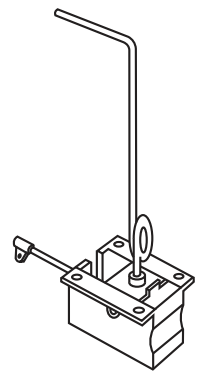

Retract landing gear VQAR03 16023

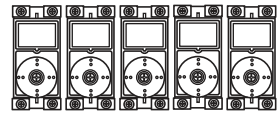

Minimum 5 channel radio for airplane with 5 servos
 .Motor control x1
 .Elevator x1
 .Rudder x1
 .Aileron x2

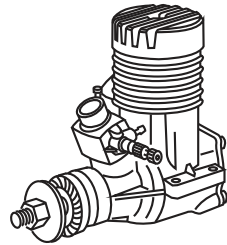

.46 ~ .50 - 2 cycle

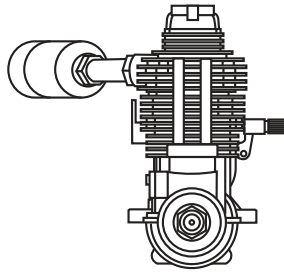

.60 ~ .70 - 4 cycle

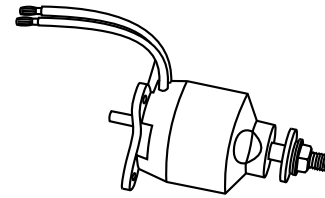

G-46 HP Motor or equivalent.

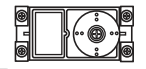

Retract servo x1

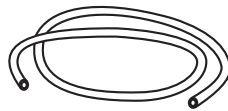

Silicone tube

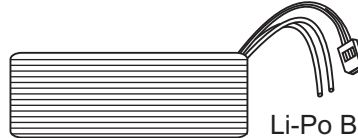

Li-Po Battery, 5 cell 4500mAh.

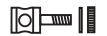

Linkage Stopper x2 (for retract servo)

GLUE (Purchase separately)



Silicon sealer

Cyanoacrylate Glue



CA



EPOXY A

Epoxy Glue (5 minute type)

Epoxy Glue (30 minute type)



EPOXY B

TOLLS REQUIRED (Purchase separately)

Hobby knife 

Phillip screw driver

Hex Wrench 

Needle nose Pliers 

Scissors 

Awl 

Sander 

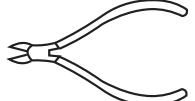
Wire Cutters 

Masking tape - Straight Edged Ruler - Pen or pencil - Rubbing alcohol - Drill and Assorted Drill Bits

The pre-covered film on ARF kit may wrinkle due to variations of temperature. Smooth out as explained right.

* Use an iron or heat gun. Start as low setting. Increase the setting if necessary. If it is too high, you may damage the film

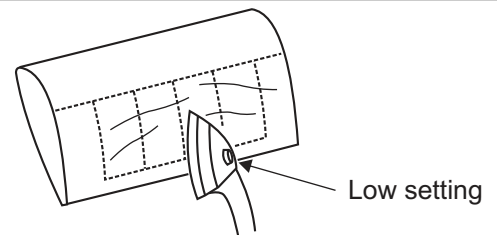



Symbols used throughout this instruction manual, comprise:

 Drill holes using the stated size of drill (in this case 1.5 mm Ø)

 Take particular care here

 Hatched-in areas: remove covering film carefully

 Check during assembly that these parts move freely, without binding

 Use epoxy glue

 Apply cyano glue

 Assemble left and right sides the same way.

 Not included. These parts must be purchased separately

Read through the manual before you begin, so you will have an overall idea of what to do.

CONVERSION TABLE

| | | | |
|---------------|----------------|---------------|-----------------|
| 1.0mm = 3/64" | 3.0mm = 1/8" | 10mm = 13/32" | 25mm = 1" |
| 1.5mm = 1/16" | 4.0mm = 5/32" | 12mm = 15/32" | 30mm = 1-3/16" |
| 2.0mm = 5/64" | 5.0mm = 13/64" | 15mm = 19/32" | 45mm = 1-51/64" |
| 2.5mm = 3/32" | 6.0mm = 15/64" | 20mm = 51/64" | |

1- Joining the wing

Cut the opening hole ($\frac{1}{2}$ "x $\frac{1}{2}$ "") throughout the balsa wood for the aileron extension cord exit.

WING - TOP VIEW

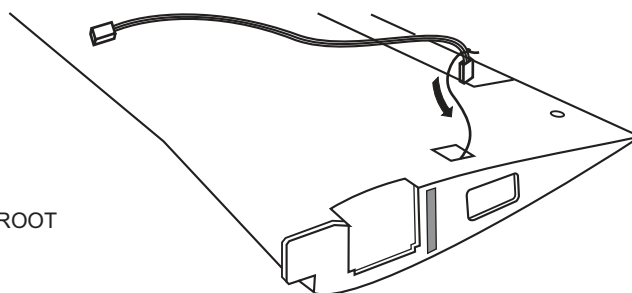
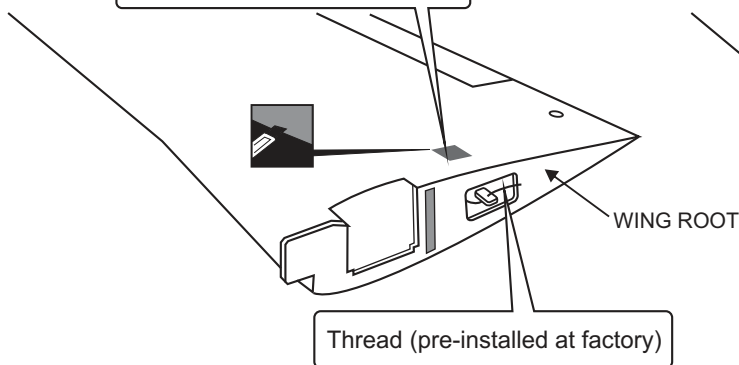

Using the thread (pre-installed at factory) to slide the aileron extension cord into the wing half.

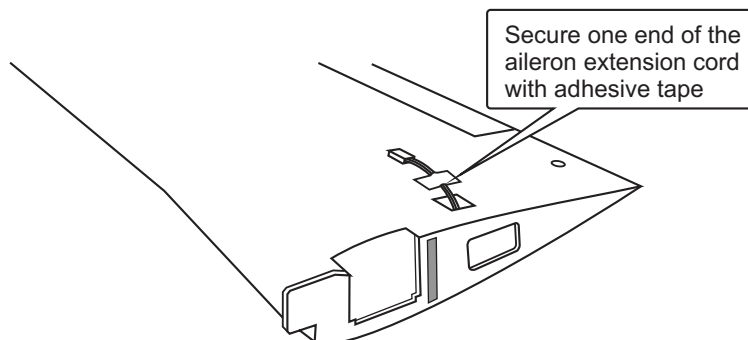

Do the same way with other wing half.

2- Joining the wing

Note: The two wing halves roots must fit together perfectly.

! Make sure to glue securely, If not properly glued, a failure in flight may occur.

Hold the wing halves together with binder clip and rubber band (not include)

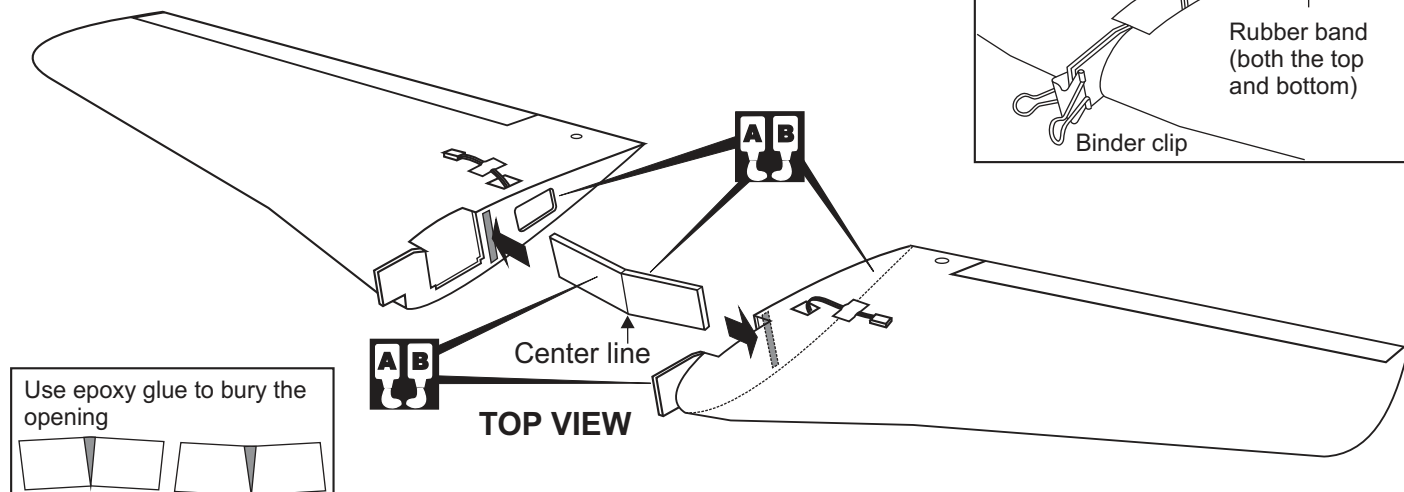
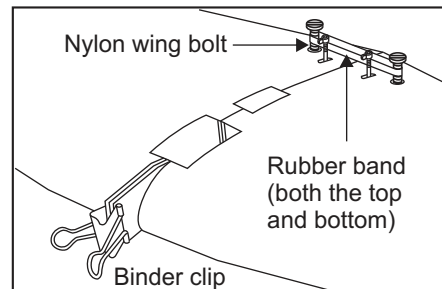

- 1- Using a pencil, mark the center of the brace.
- 2- Trial fit the wing joiner into one of the wing panels. It should insert smoothly up to the center line marked above.
- 3- Slide the other wing half onto the dihedral brace until the wing panel meet. If the fit is over tight, it may be necessary to lightly sand the dihedral brace.
- 4- Check for the correct dihedral angle.
- 5- Mix up some 30 minute epoxy and apply a generous amount of epoxy into the wing joiner cavity of one wing half.
- 6- Coat one half of the dihedral brace with epoxy up to the center line. Install the epoxy-coated side of the dihedral brace into the wing joiner cavity up to the center line, marking sure that the "V" of the dihedral brace is positioned correctly
- 7- Do the same way with the other wing half.
- 8- Carefully slide the wing halves together, ensuring that they are accurately aligned. Firmly press the two halves together, allowing the excess epoxy to run out. Clean off the excess epoxy.

IMPORTANT: Please do not clean off the excess epoxy on the wing with strong solvent or pure alcohol, only use kerosene to keep the colour of your model not fade.

3- Retract servo tray

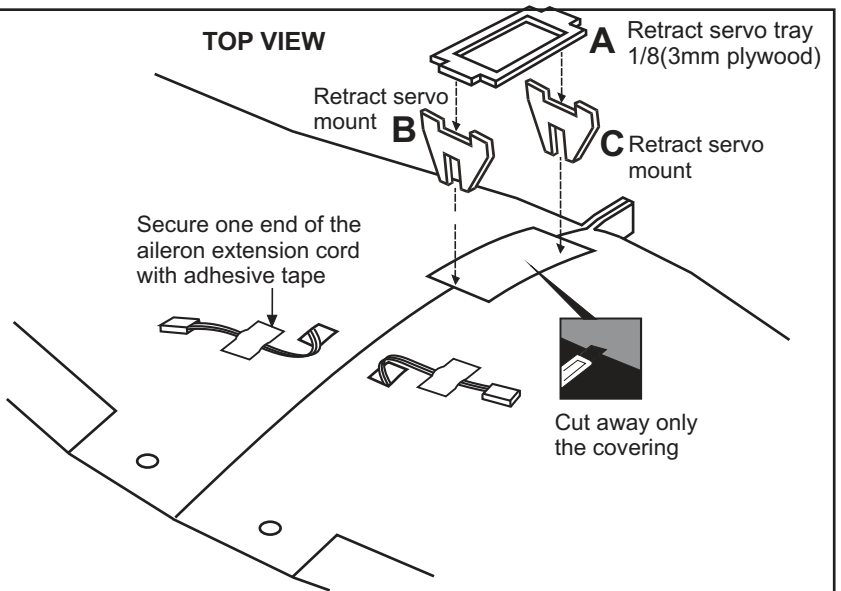
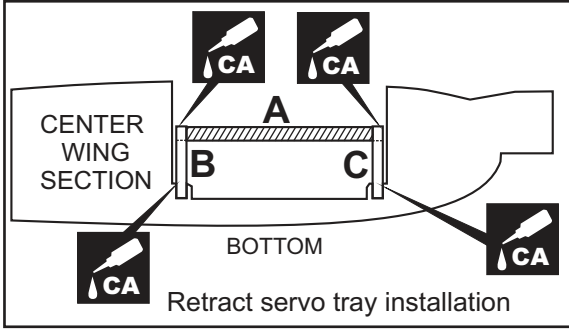

4- Servo Installation

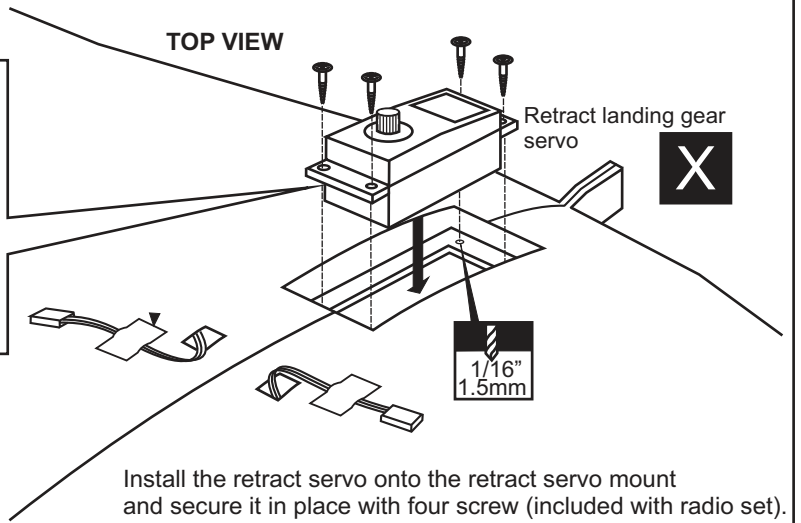
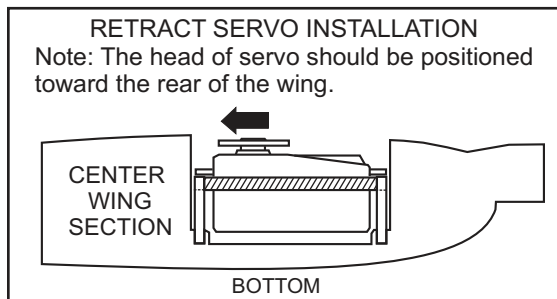

5- Retract landing gear installation

Trial fit the push rod into the wing. Join the pushrod to the retract gear arm and trial fit the retract into the wing.

After checking that the retract works smoothly, fix the retract on the wing with 3x20mm self tapping screws. Do the same way with other half wing.

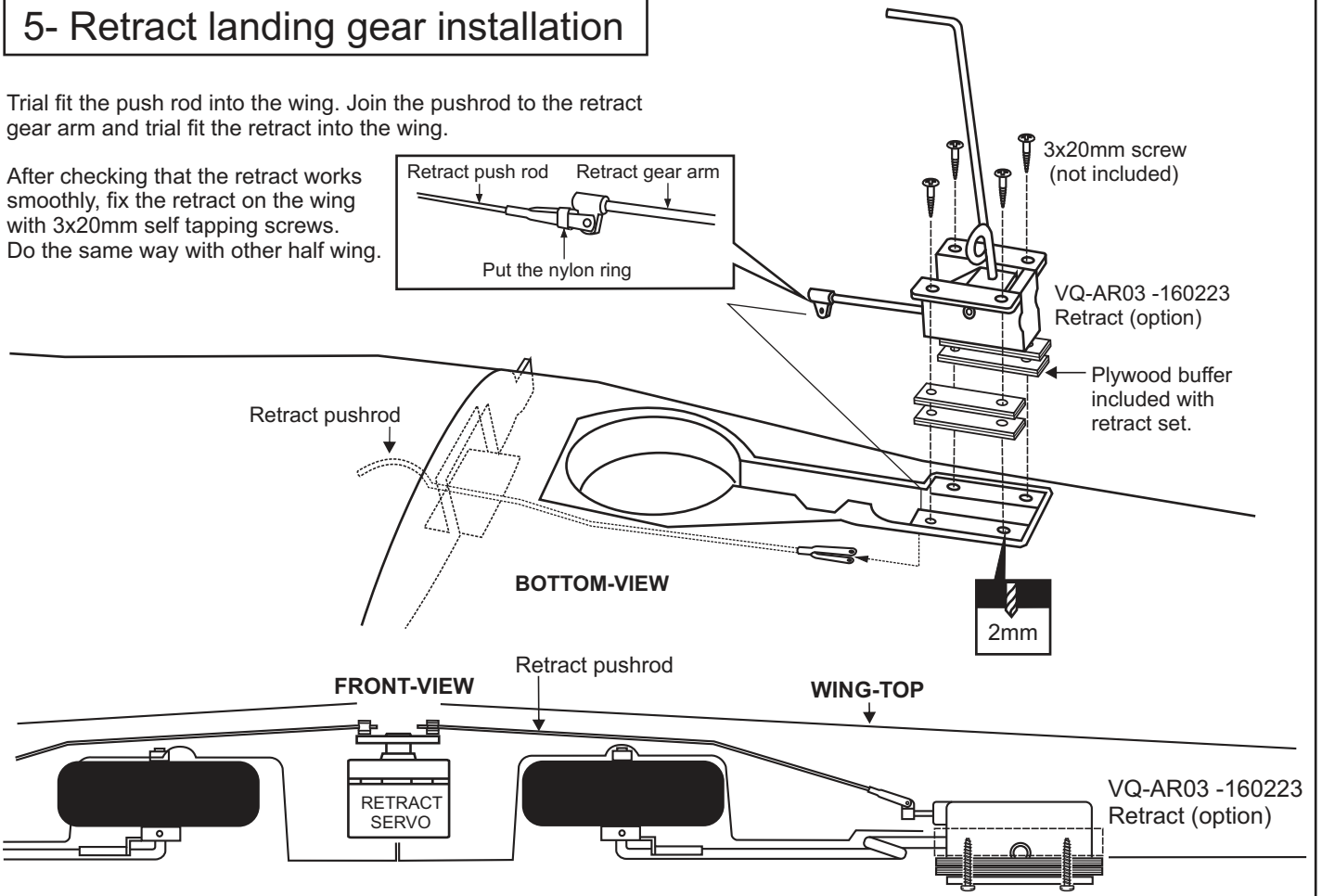
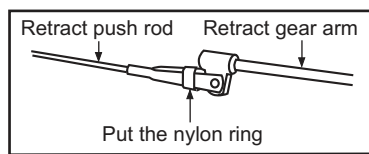

6- Retract landing gear Installation

Link the servo and retract gear arm with push rod. Be sure to adjust the stroke so that the landing gear locks in both up and down position.

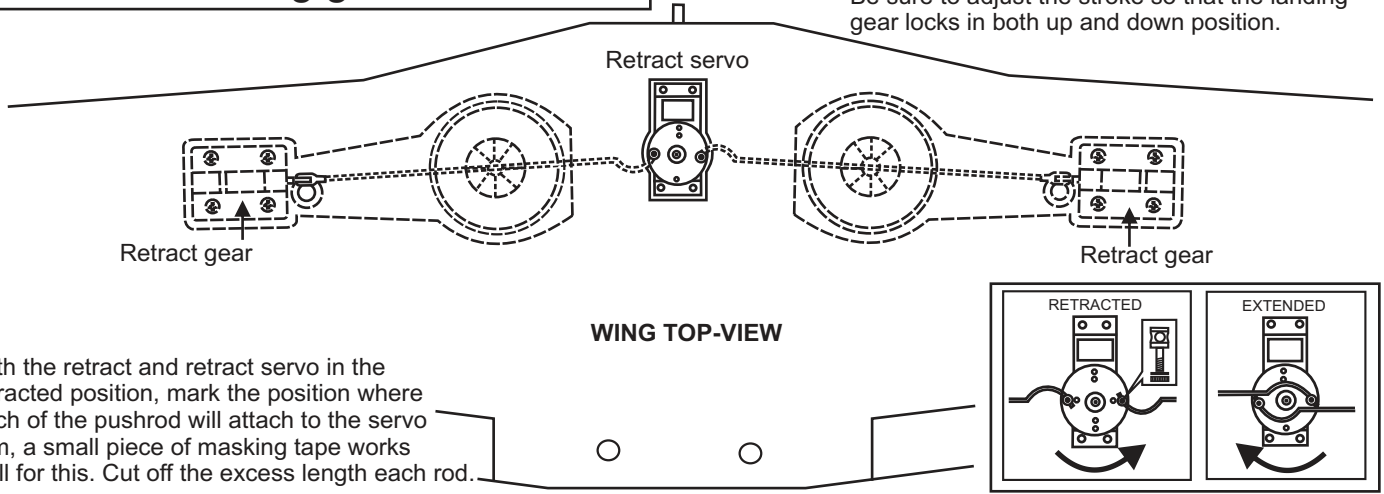

With the retract and retract servo in the retracted position, mark the position where each of the pushrod will attach to the servo arm, a small piece of masking tape works well for this. Cut off the excess length each rod.

7- Electric retract landing gear / Einziehfahrwerk

ELECTRIC RETRACT LANDING GEAR

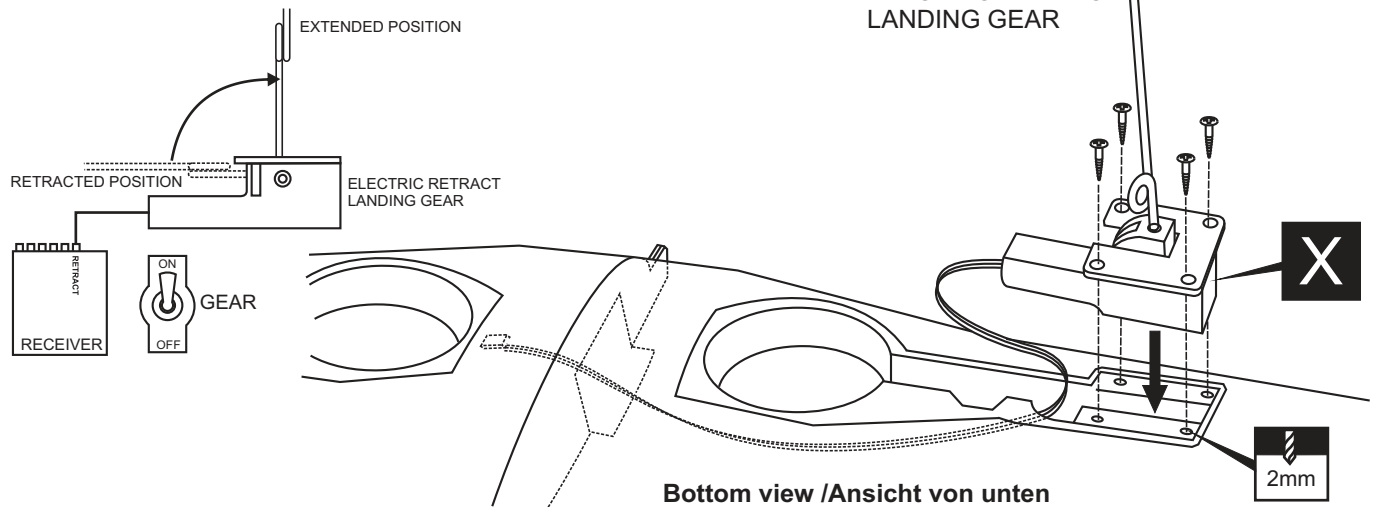

8- Fixed gear / Starres Fahrwerk

3x12mm screw

.....8

3x20mm screw

.....16

Nylon gear strap

.....4

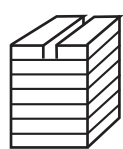

Gear mount x 2

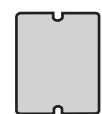

Ply gear mount plate x 2

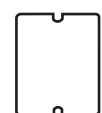

Square plastic x 2

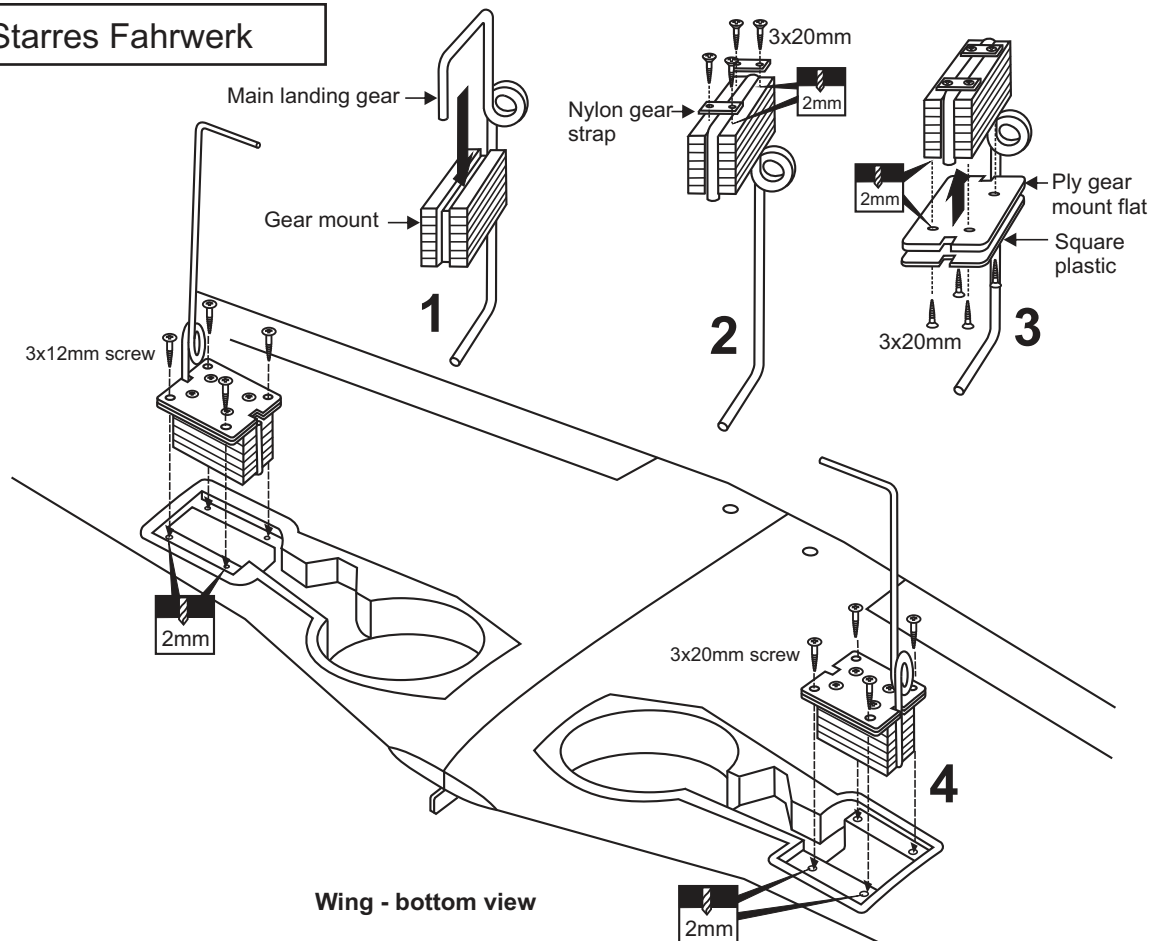

9- Fixed gear / Starres Fahrwerk

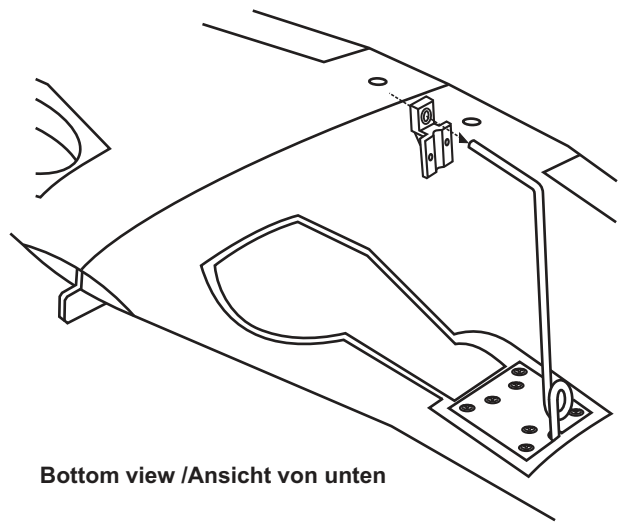
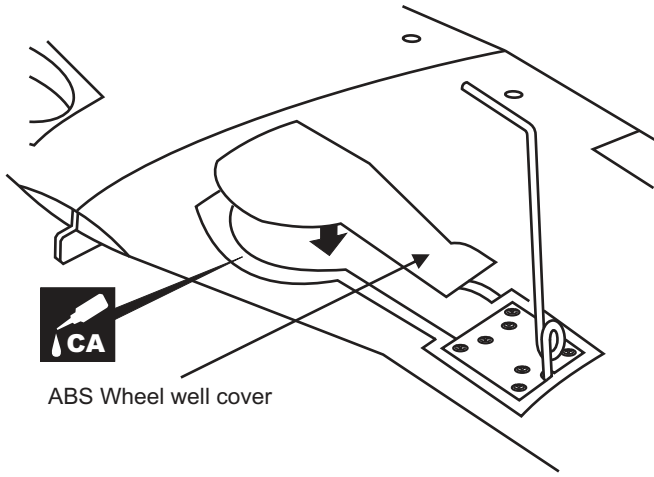

10- Fixed gear / Starres Fahrwerk

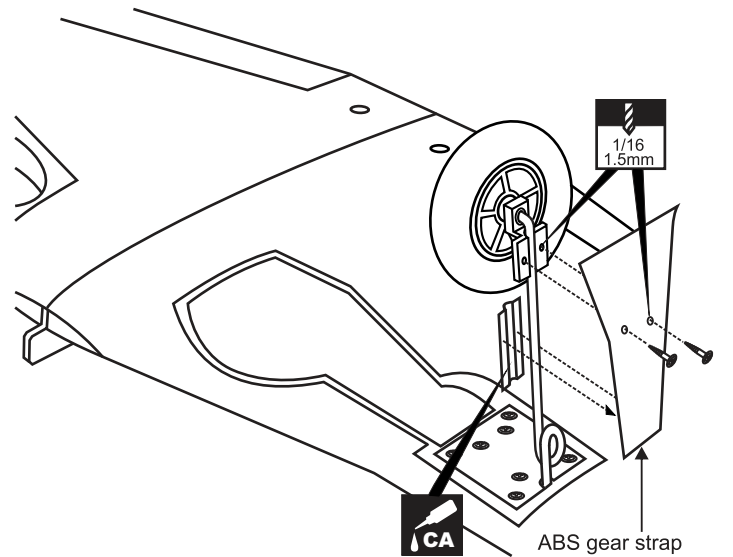
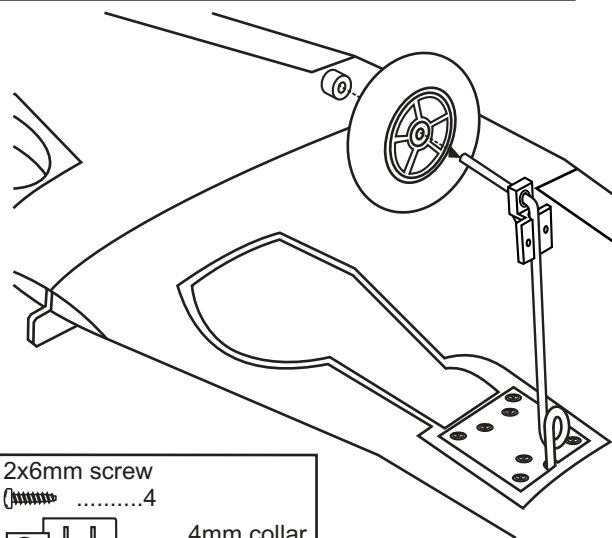

2x6mm screw

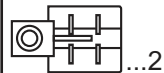
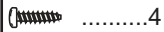

4mm collar



11- Wing bolt flat / Verstärkung

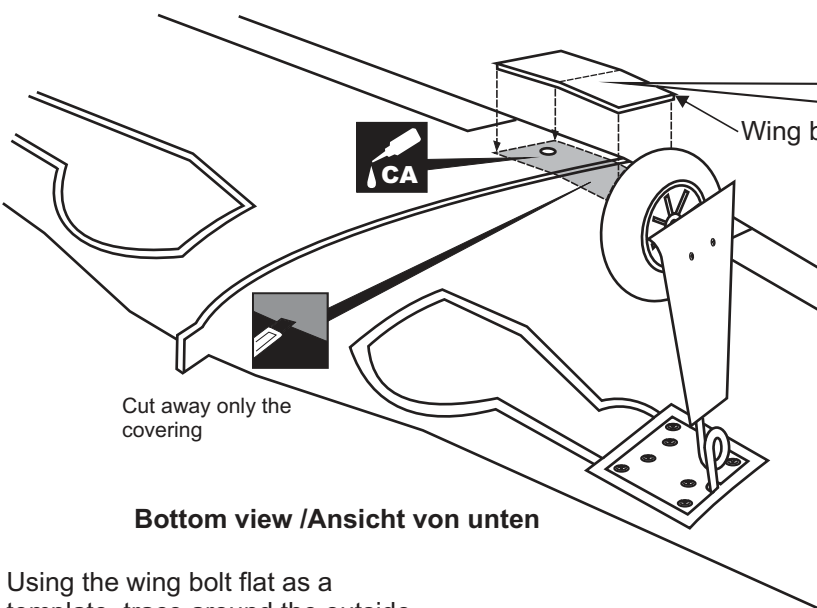

Wing bolt flat 1/8"(3mm)plywood

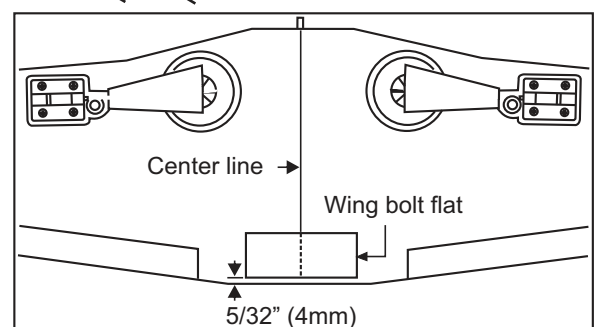
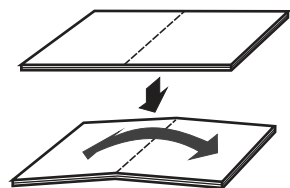

Using the wing bolt flat as a template, trace around the outside edge of the wing bolt flat and then remove it. Using a sharp hobby knife, cut away the covering inside the lines. Not to cut into the wood. Apply the wing bolt flat in place and secure it with CA glue.

12- Wing bolt flat / Verstärkung

Drill the holes throughout the wing bolt flat, **from the top to the bottom** of the wing.

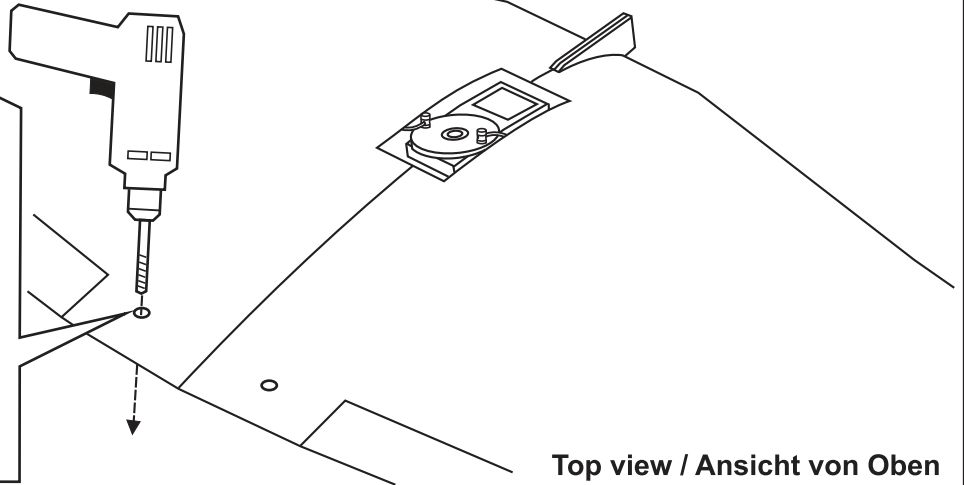
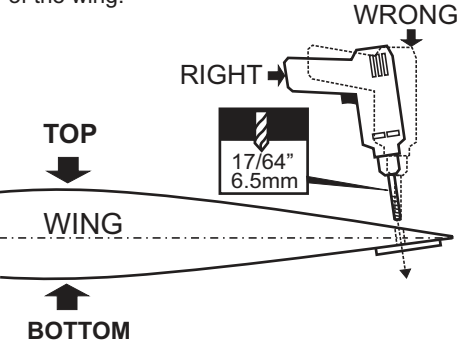



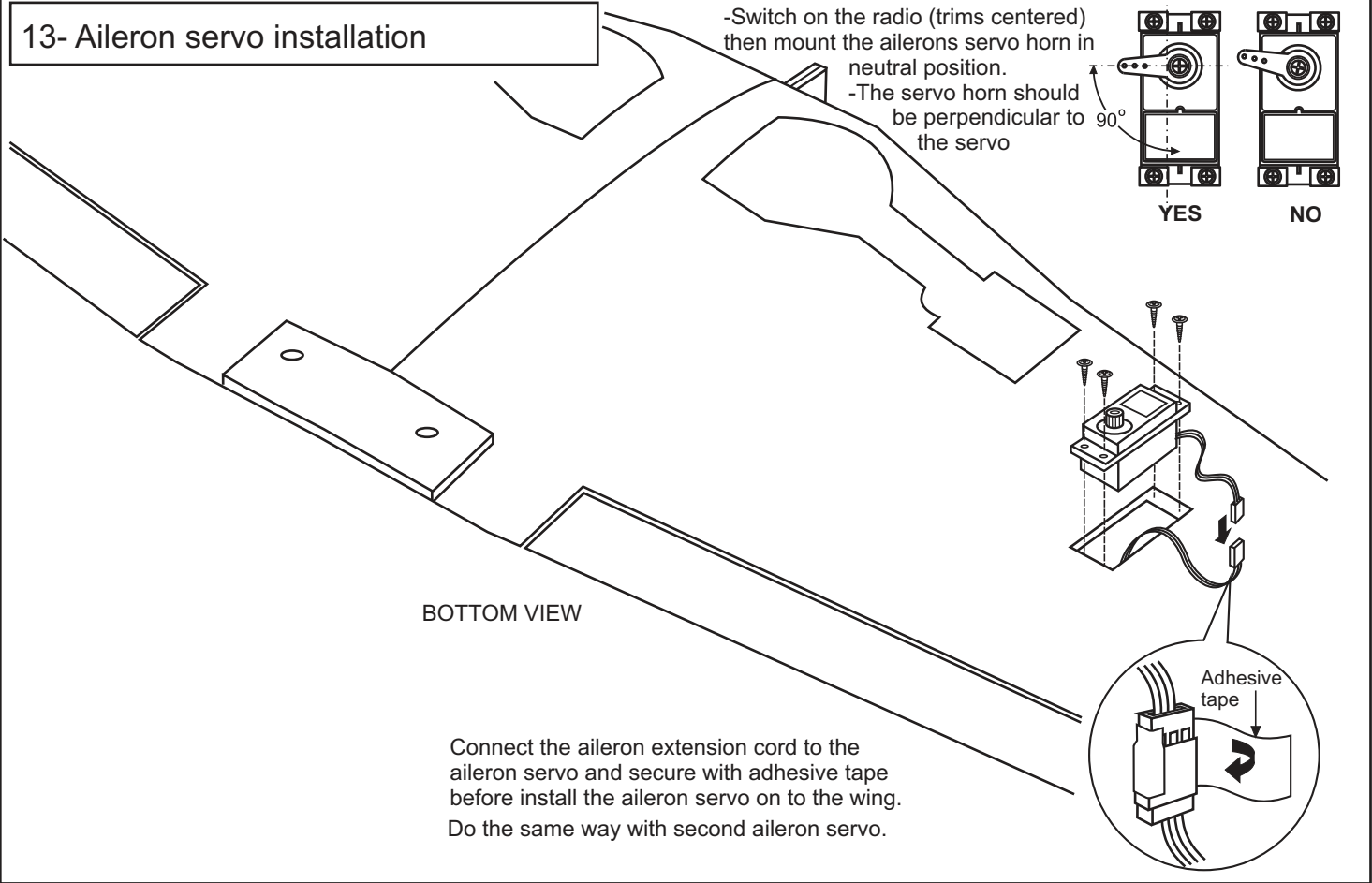
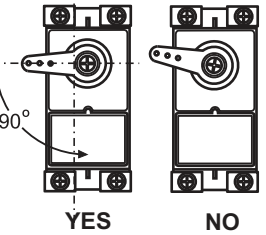

13- Aileron servo installation

-Switch on the radio (trims centered) then mount the ailerons servo horn in neutral position.

-The servo horn should be perpendicular to the servo



14- Aileron linkage

| | |
|---|--|
| Plastic control horn | Connector |
|  | 2 |
|2 | 2 |
| 2x20mm screw | Aileron push rod |
| 4 | 2 |

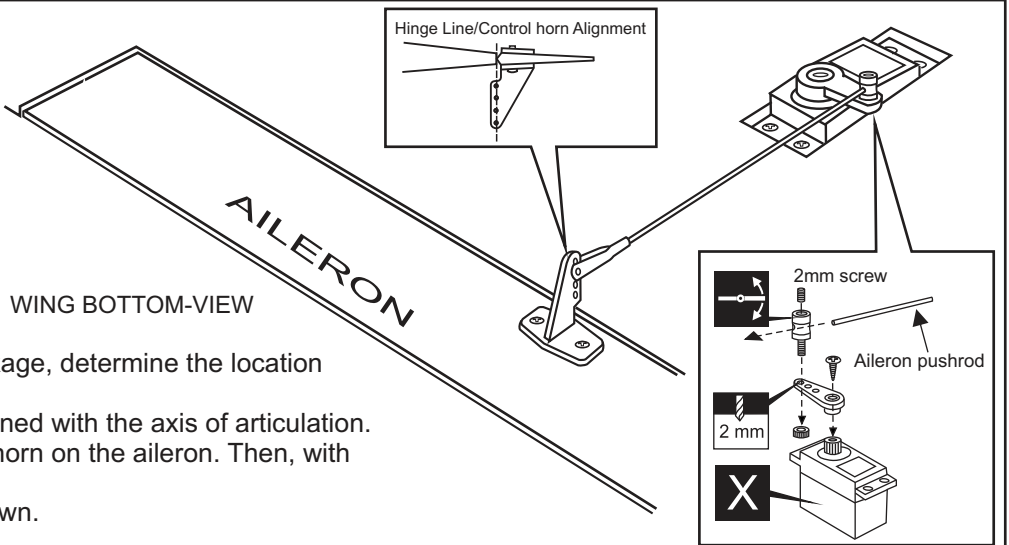

Depending on the position of the linkage, determine the location of aileron control horn.
The horn holes must be perfectly aligned with the axis of articulation.
Mark the position of the "foot" of the horn on the aileron. Then, with the drill, make the 2 holes.
Install the aileron control horn as shown.

15- Air Scoop/wing cover

6x40mm nylon bolt

2

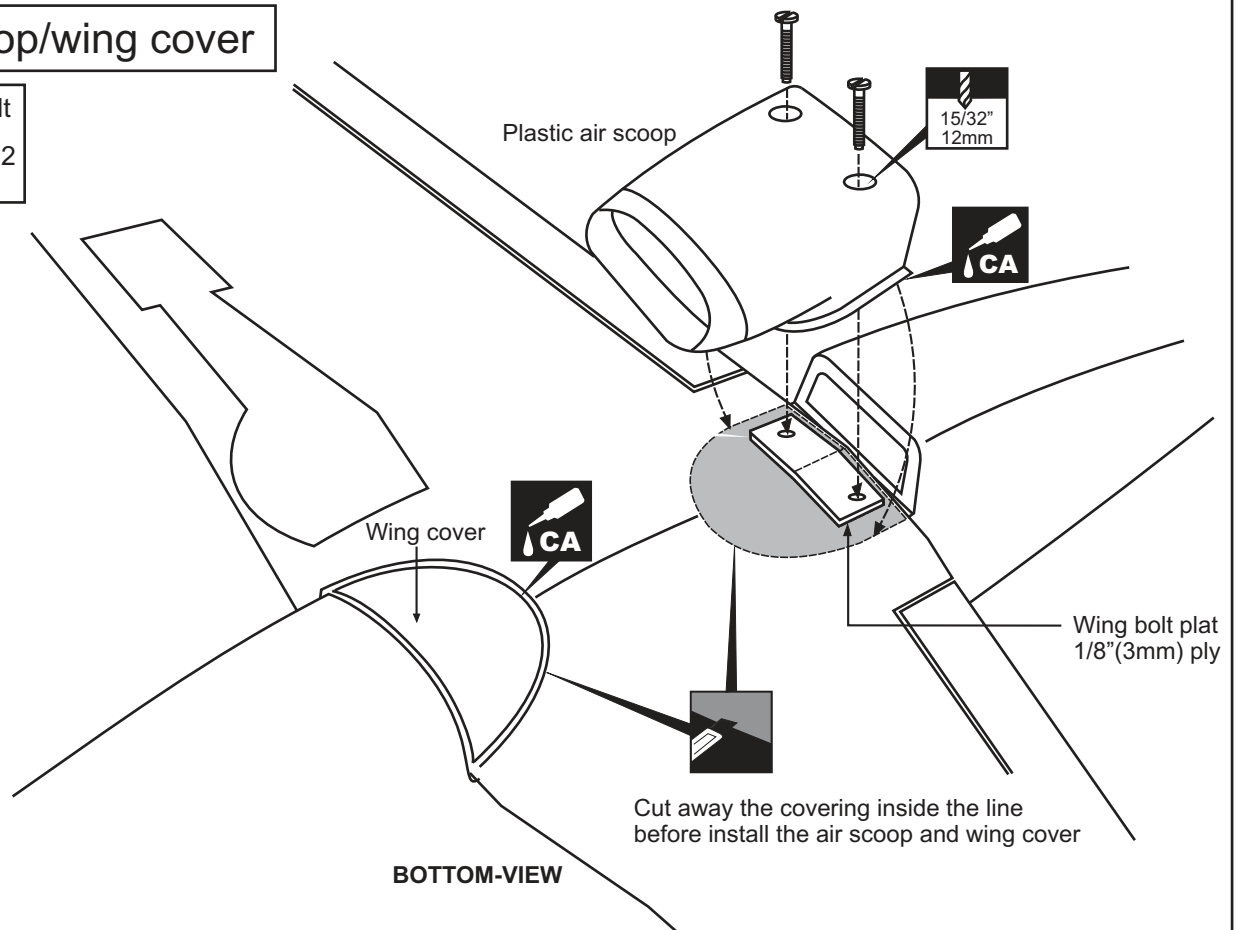

- 1-Using the ABS air scoop as a template, trace around the outside edge of the ABS air-scoop, and then remove it.
- 2-Using a sharp hobby knife, cut away the covering inside the lines. Not to cut into the wood.
- 3-Apply the ABS air scoop in place and secure with CA glue. Do the same way with the ABS wing cover.

16- Air Scoop/wing cover

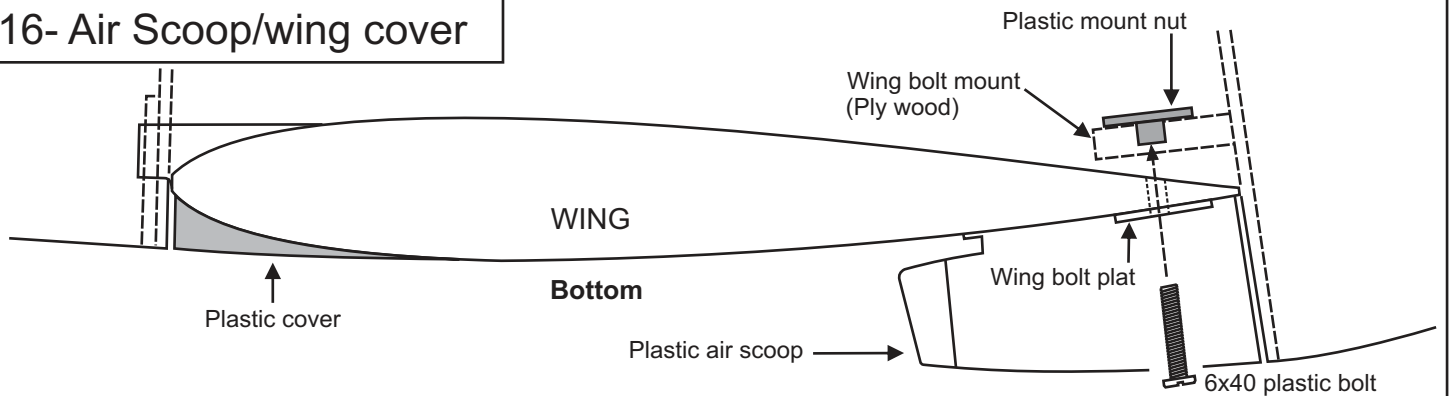

17- Installing the wing

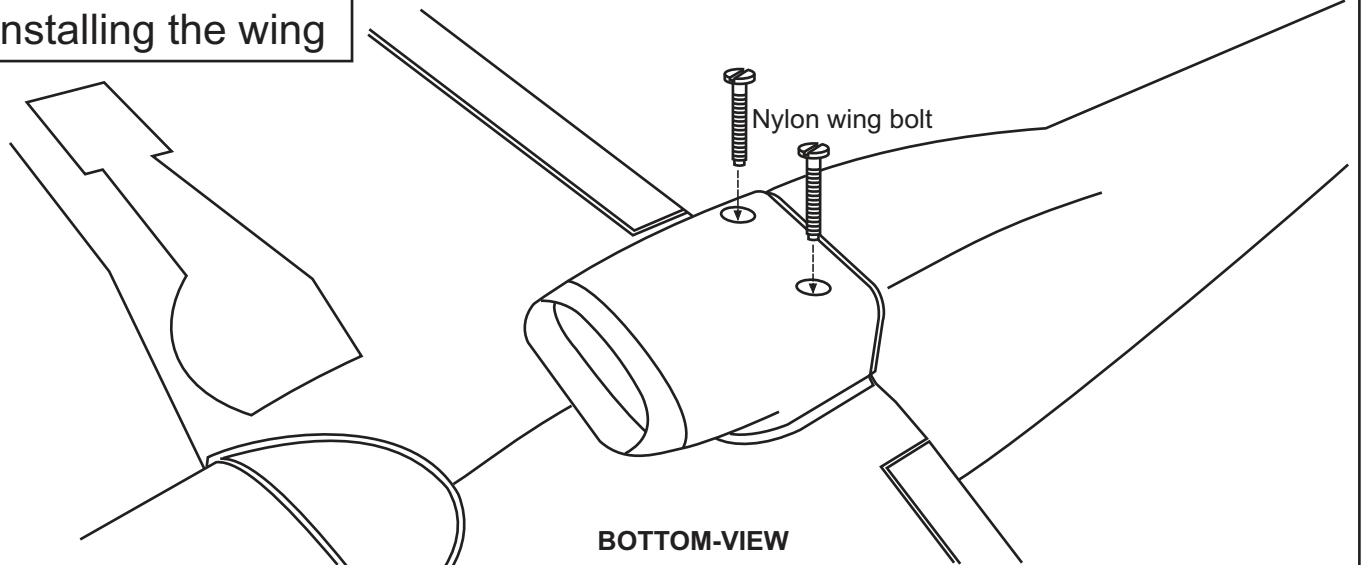

18- Horizontal stabilizer

Cut away only the covering both the right and left side



Cut away only the covering both the top and bottom side*



Both the top and bottom side

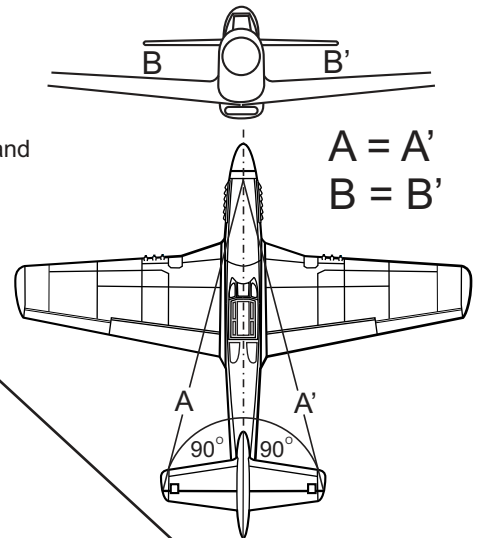

1-Trial fit the horizontal stabilizer in place .

Check the alignment of the horizontal stabilizer. When you are satisfied with the alignment, use a pencil to trace around the top and bottom of the stabilizer where it meets the fuselage.

2-Remove the horizontal stabilizer from the fuselage. Using the sharp hobby knife, carefully cut away the covering inside the lines which were marked above.

3-Spread epoxy (30 minute) onto the top and bottom of the horizontal stabilizer along the area where the covering was removed and to the fuselage where the horizontal stabilizer mounts.

4-Install the horizontal stabilizer into the fuselage and adjust the alignment as described in step 1

5-Wipe off any excess epoxy using a paper towel and rubbing alcohol.

Allow the epoxy to cure before proceeding to next step.

* **WARNING:** When removing any covering from the airframe, please ensure that you secure the cut edge with CA or similar cement. This will ensure the covering remain tight.

19- Vertical stabilizer

Cut away only the covering both the right and left side*



Both the left and right side



1-Trial fit the vertical stabilizer in place . Check the alignment of the vertical stabilizer. When you are satisfied with the alignment, use a pencil to trace around the right and left of the stabilizer where it meets the fuselage.

2-Remove the vertical stabilizer from the fuselage. Using the sharp hobby knife, carefully cut away the covering inside the lines which were marked above.

3-Spread epoxy (30 minute) onto the right and left and bottom of the vertical stabilizer along the area where the covering was removed and to the fuselage where the vertical stabilizer mounts.

4-Install the vertical stabilizer into the fuselage and adjust the alignment as described in step 1.

Allow the epoxy to cure before proceeding to next step.

IMPORTANT: Please do not clean off the excess epoxy with strong solvent or pure alcohol, only use kerosene to keep the colour of your model not fade.

5-Push the rudder and its hinges into the hinge slots in the trailing edge of the vertical stabilizer. There should be a minimal hinge gap.

When satisfied with the and alignment, hinge the rudder to the vertical stabilizer using thin CA glue. Make sure to apply a thin CA glue to the left and right of both hinges and to inside the hinge slots.



Thin CA

$C = C'$

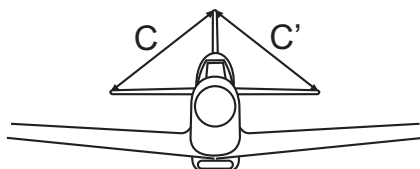

Securely glue together. If coming off during flight, you lose control of your air plane.

Control horn



.....1

2x12mm

.....2

* **WARNING:** When removing any covering from the airframe, please ensure that you secure the cut edge with CA or similar cement. This will ensure the covering remain tight.

20- Elevator installation

Vergewissern Sie sich, sauber geklebt zu haben. Andernfalls können Probleme mit der Flugeigenschaft auftreten!

Securely glue together. If coming off during flight, you lose control of your air plane.

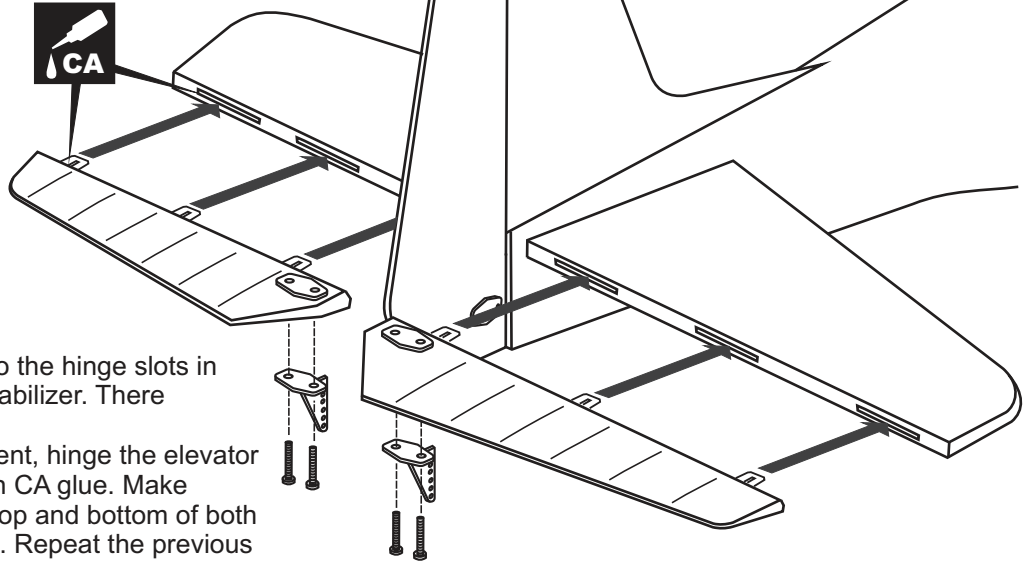
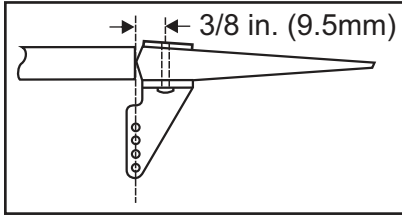

push the elevator and its hinges into the hinge slots in the trailing edge of the horizontal stabilizer. There should be a minimal hinge gap. When satisfied with the and alignment, hinge the elevator to the horizontal stabilizer using thin CA glue. Make sure to apply a thin CA glue to the top and bottom of both hinges and to inside the hinge slots. Repeat the previous procedures to hinge the second elevator to the other side of the horizontal stabilizer.

Control horn

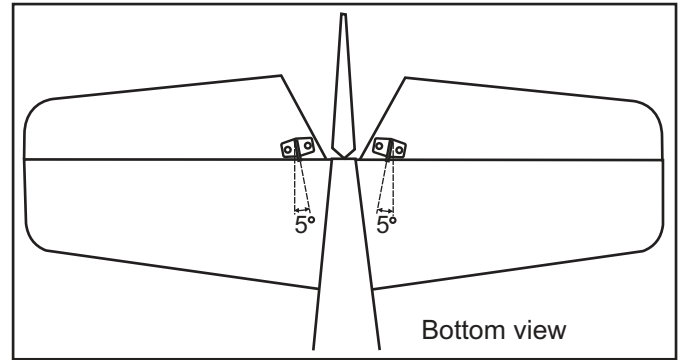
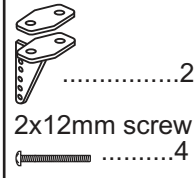

21- Tail gear

5/64 in.(2mm) I.D collar

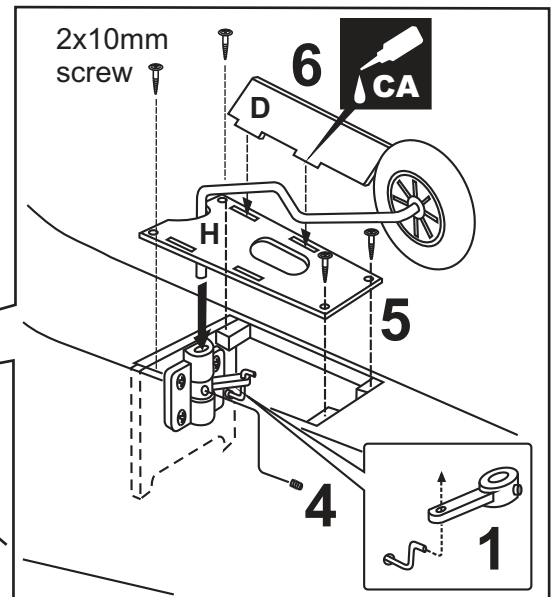
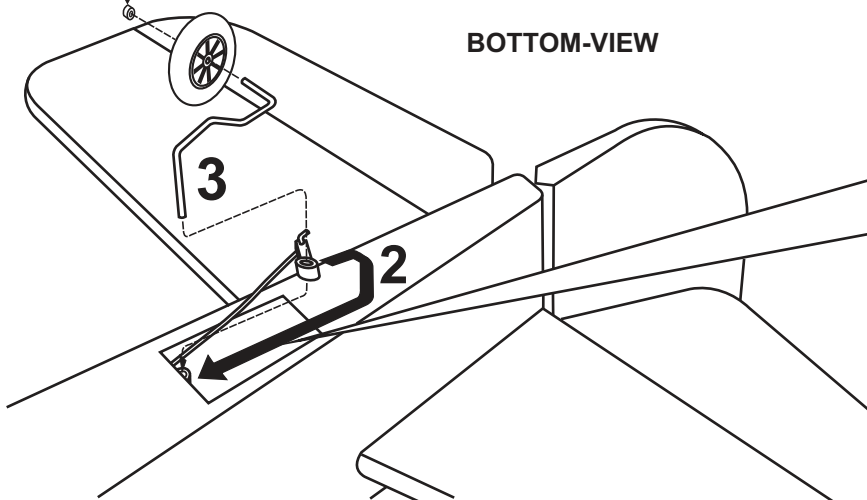

- 1- Insert the tail wheel pushrod into the hole on the tail gear control horn (as show).
- 2- Install the tail wheel control horn in place.
- 3- Instal the tail wheel gear in place.
- 4- Secure the tail wheel control horn in place using a 5/64"(2mm) screw set, Ensure smooth non-binding movement.
- 5- Installing the tail wheel hatch (H) in place using a four 5/64x25/64"(2x10mm) self tapping screws.
- 6- Attach the tail wheel doors (D) in place using CA glue.

| | |
|-------------------------|-------------------|
| 2x3mm screw | 2mm I.D collar |
|1 |1 |
| 2x10mm screw | Tail landing gear |
|4 |1 |
| Tail wheel control-horn |1 |
|1 | |

22- Engine mount - engine

5/32x1"
4x25mm screw ...4
Blind-nut4

1/8x5-1/64"
3x20mm screw ...4
1/8"(3mm) nut4

! Align the mark on both mounts with the mark on the fuselage

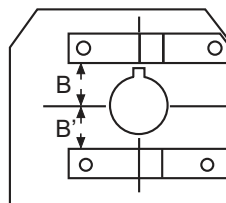
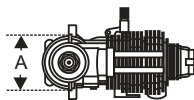

B=B'

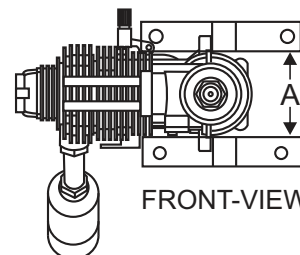

FRONT-VIEW

- Using a pencil or felt tipped pen, mark the fire wall where the four holes are to be drilled



- Remove the engine mount and drill a 13/64"(5mm) hole through the fire-wall at each of the four marks marked.



- Reposition the engine mounts on to the fire-wall. Attach the four blind-nut to the fire-wall as show. Secure them with four 4x25mm screw.



- Position the engine on to the engine mounts so the distance from the prop hub to the fire wall is 5-1/8"(127mm)

- Mark the engine mounting plate where the four holes are to be drilled.

Note: Mark the mounting plate through the engine mounting flanges.

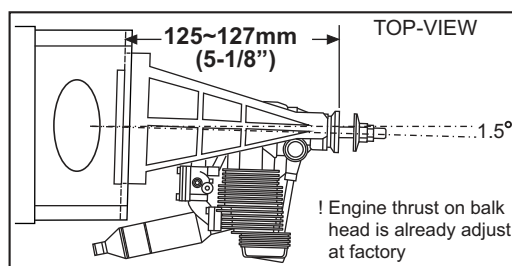

- Remove the engine and drill a 1/8"(3mm) holes through the beam at each of the four marks made above.



- Reposition the engine on the engine mount beams, aligning it with the holes. Secure the engine to the engine mount using four 1/8x51/64"(3x25mm) screws.

Note: Apply Silicon sealer to each of the 1/8x51/64" screw.

23- Fuel tank

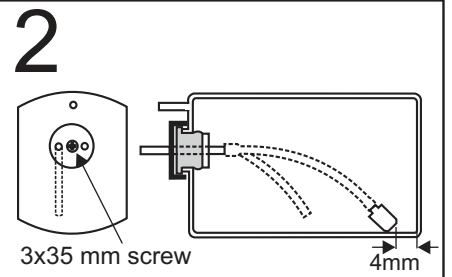
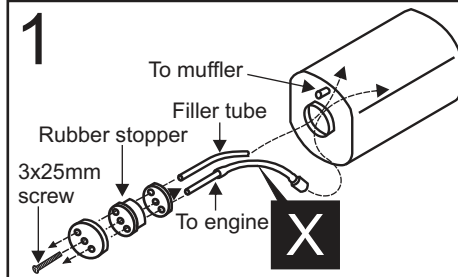
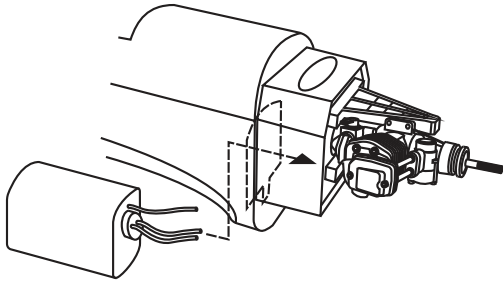

After confirming the direction . Insert this assembly, clunk end first, into the fuel tank and tighten and screw the fuel tank cap on firmly.

Checking for leaks - block the vents and blow into the feed - if in doubt submersing the tank in a blow of water will show up any problems

24- Electric motor

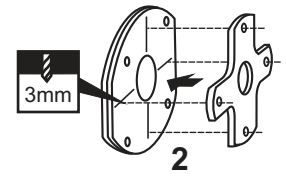
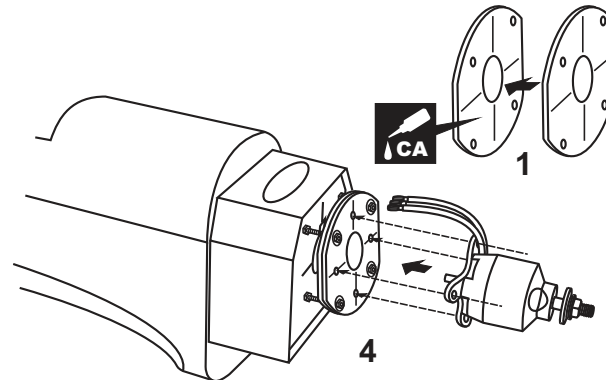
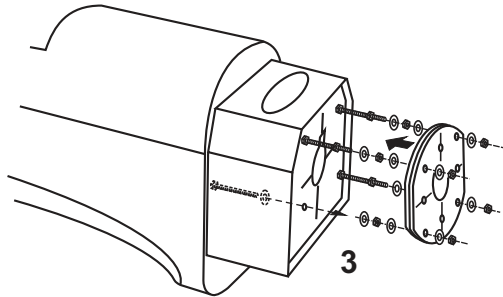

Using a aluminum motor mounting plate as a template, mark the plywood motor mounting plate where the four holes are to be drilled (2).

Remove the aluminum motor mounting plate and drill a 1/8" (3mm) hole through the plywood at each of the four marks marked .

Note: The aluminum motor mounting included with electric motor set.

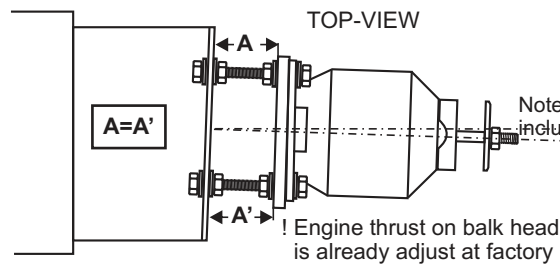
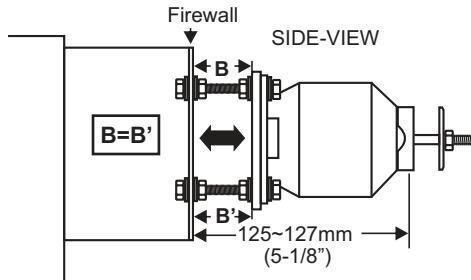

25- Radio and battery

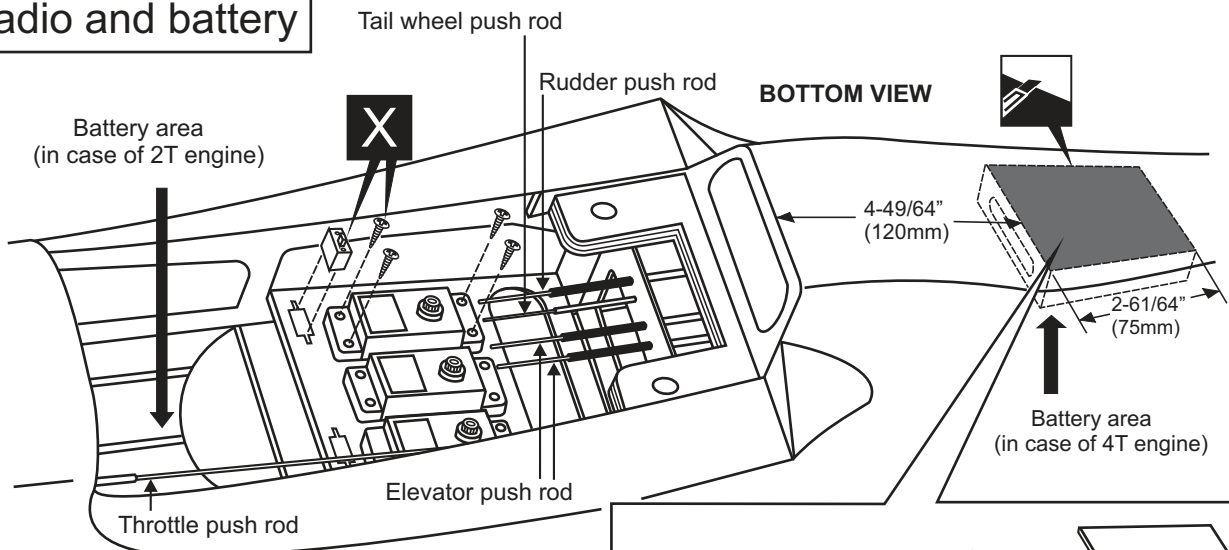

Carefully cut a 2-9/32" (58mm) wide area which is 2-61/64" (75mm) in length through both the covering and the balsa wood. Remove the excess balsa. Put the battery pack into the box (pre-built at factory) and fasten down with rubber bands or similar, ensuring it will not come loose or rattle during flights.

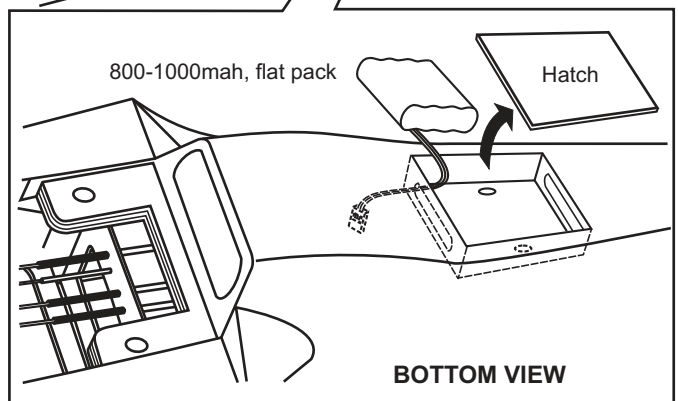
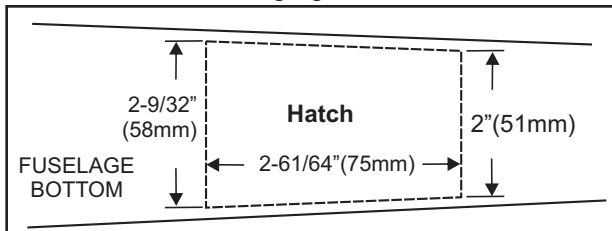

Link the battery wire with the battery extension cord. Reposition the hatch in place and secure it with CA glue.

26- Linkages

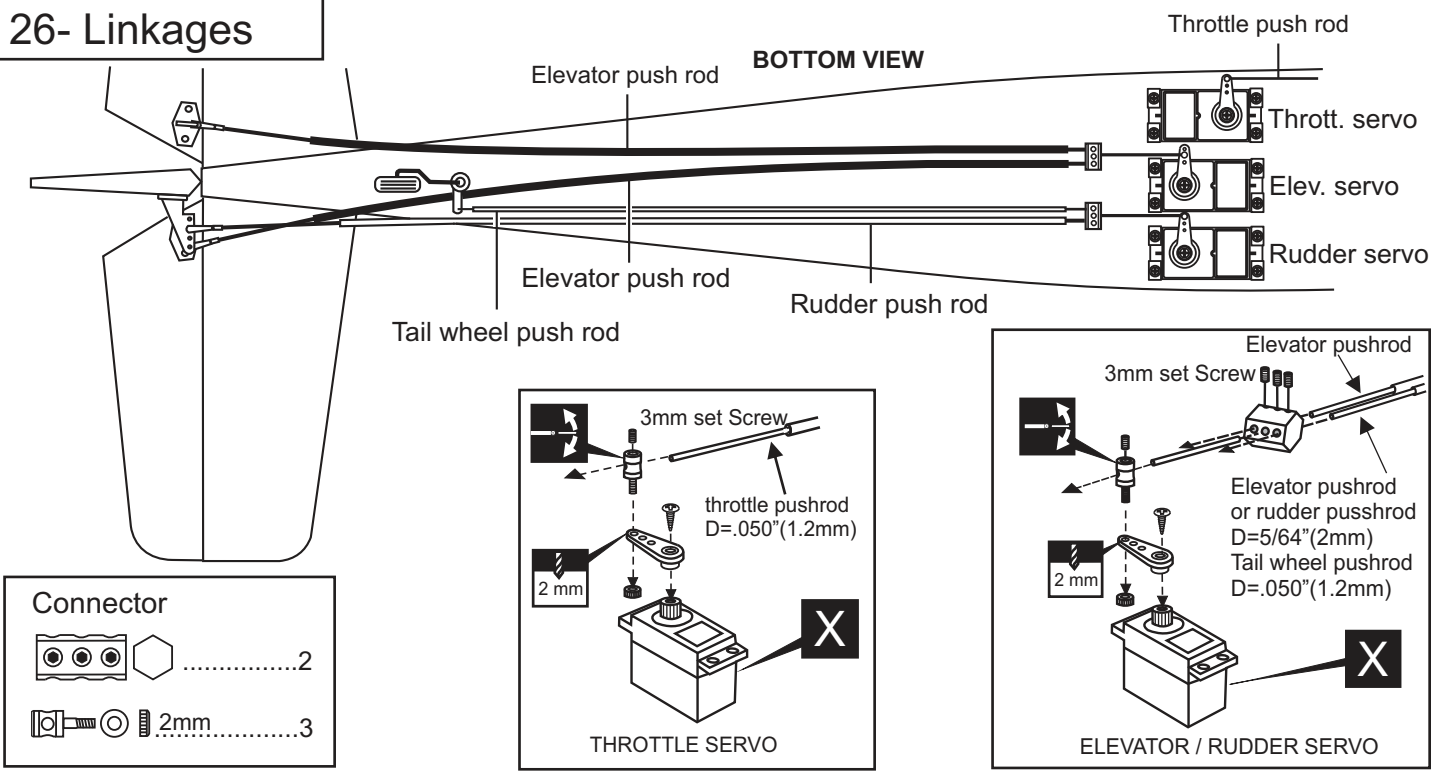

27- Cowling installation

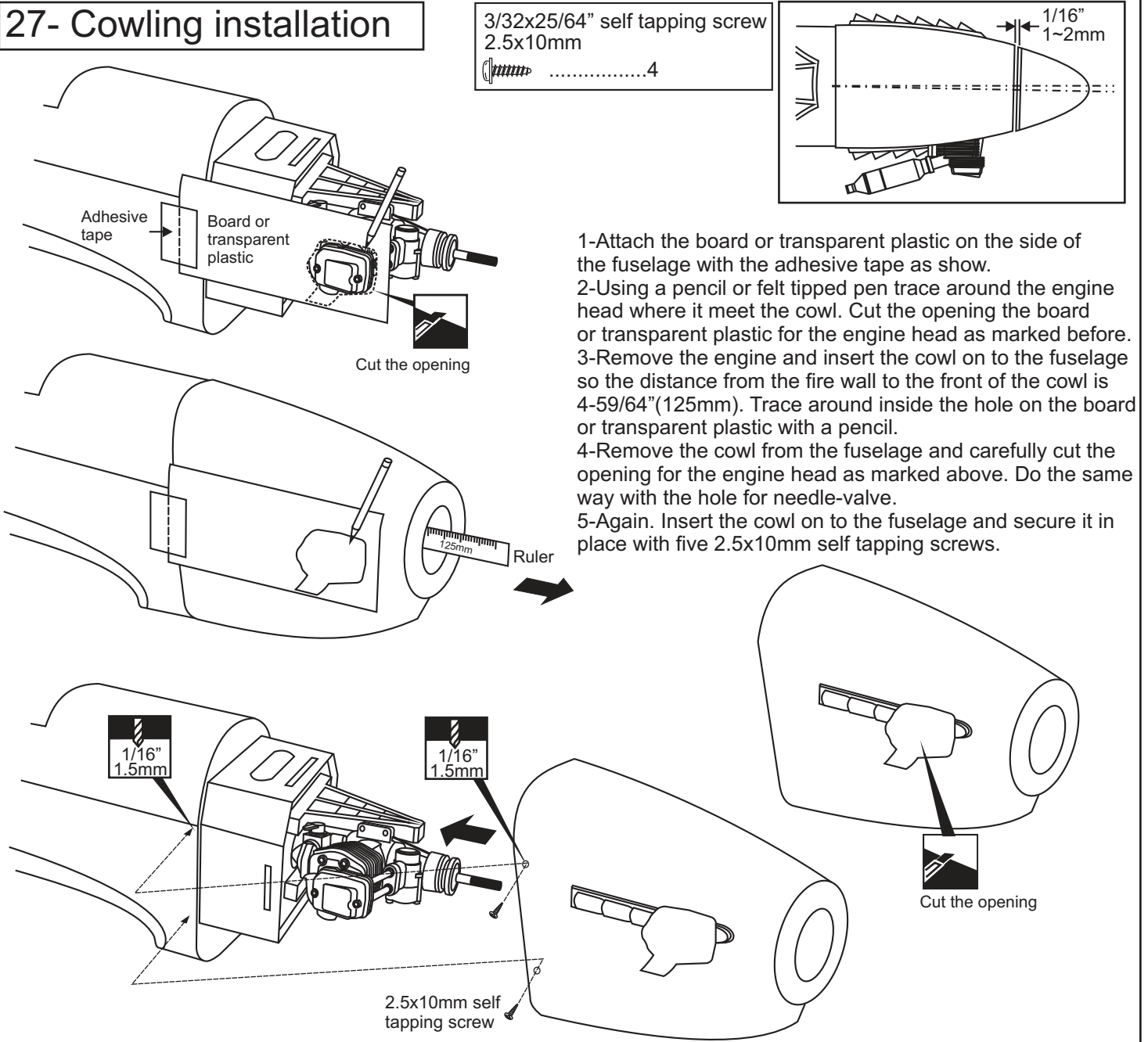

28- Decor

Note: Cut out the stickers and apply them in the proper area. Do not peel the backing paper off all at once. Peel off one corner of the backing and cut off with scissors. Arrange sticker on model and when satisfied adhere the corner without backing. Carefully peel back the rest of the backing while at the same time adhering the rest of the sticker.

Try not to make air bubbles, if there are some, carefully puncture sticker (center of bubble) but not model surface with the tip of the knife or sharp pin and squeeze out the air. At curves stretch sticker and apply a little heat so that no ceases occur. Cut off the excess that is produced.

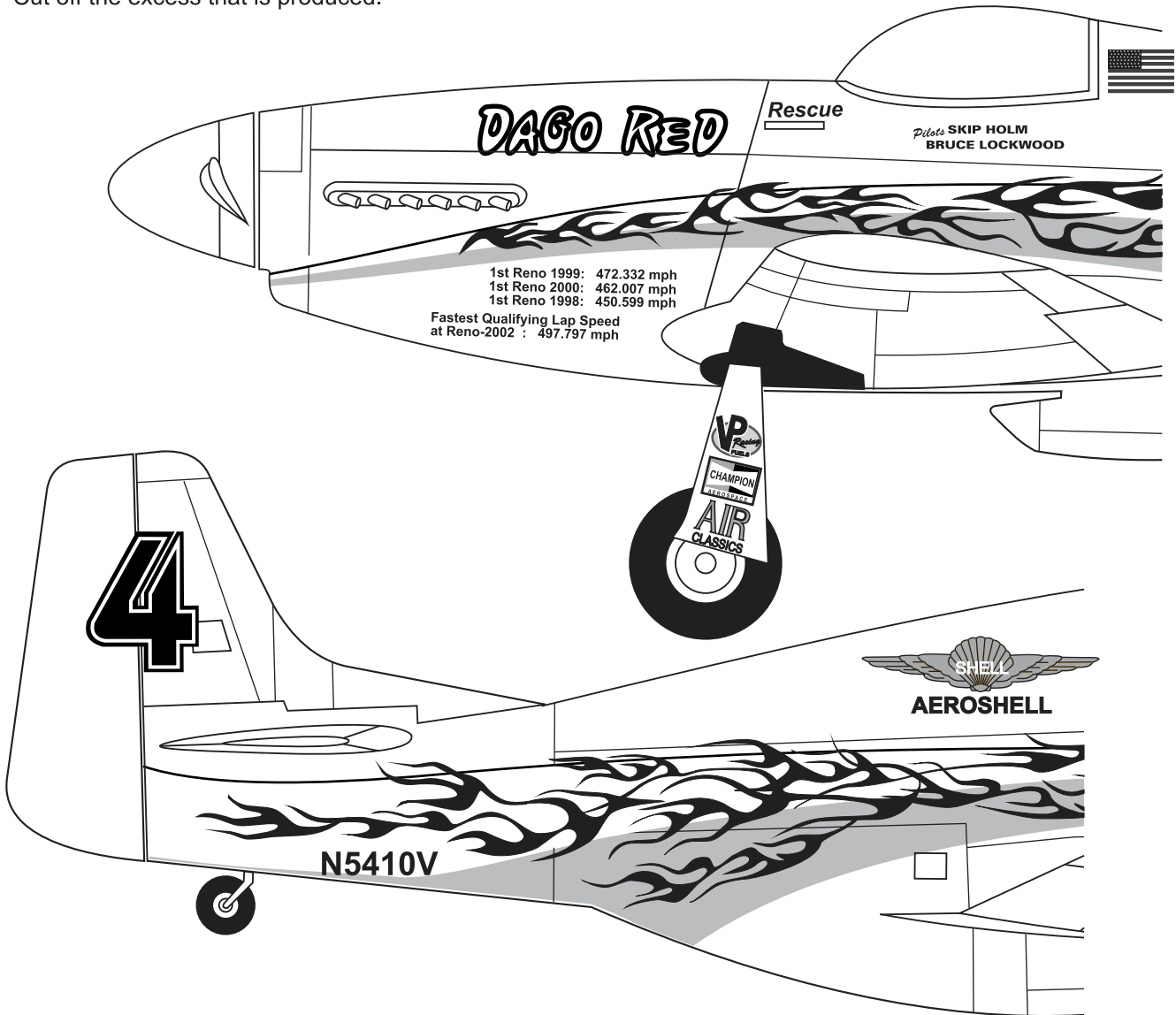

29- Balance

DO NOT try to fly an out-of-balance model !

Note: If necessary, move the battery pack or add weight to either the tail or nose until the correct balance is achieved.

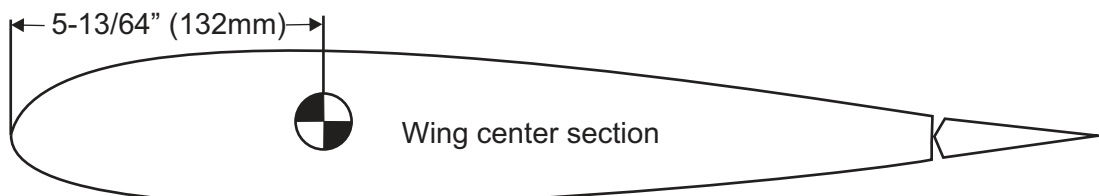

30 Control Surface

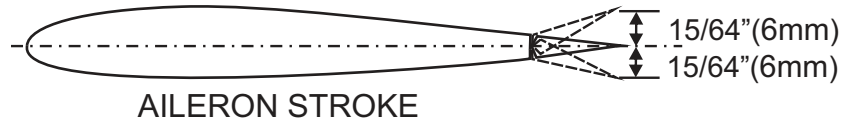

AILERON STROKE

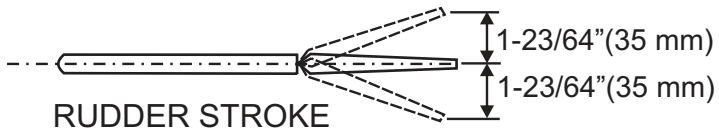

RUDDER STROKE

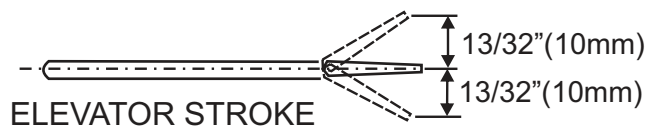

ELEVATOR STROKE

Adjust the travel of the control surfaces to achieve the values stated in the diagrams.
These value will be suitable for average flight requirements. Adjust the values to suit your particular needs.

IMPORTANT: Please do not clean your model with pure alcohol, only use liquid soap with water or use glass cleaner to clean on surface of your model to keep the colour not fade.

All details are subject to change without notice !