

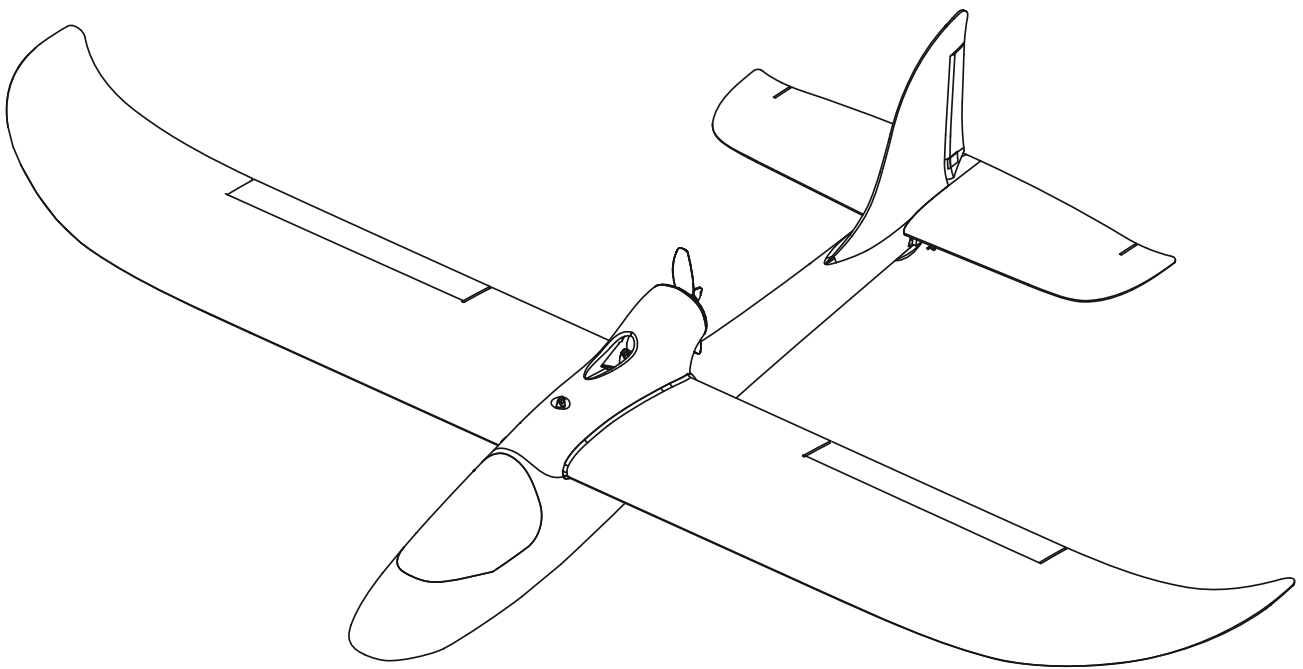

1280mm Easy Trainer V2



Instruction Manual
Bedienungsanleitung
Manuel d'utilisation
操作手册

SIMPLE
• SIMPLE ASSEMBLY

RIGID
• STRONG DURABLE EPO

STABLE
• SMOOTH FLYING PERFORMANCE

FMSMODEL.COM

WARNING

WARNING: Read the ENTIRE instruction manual to become familiar with the features of the product before operating. Failure to operate the product correctly can result in damage to the product, personal property and cause serious injury.

This is a sophisticated hobby product and NOT a toy. It must be operated with caution and common sense and failure to do so could result in injury or damage to the product or other property. This product is not intended for use by children without direct adult supervision.

This manual contains instructions for safety operation and maintenance. It is essential to read and follow all the instructions and warnings in the manual prior to assembly, setup or use, in order to operate and avoid damage or serious injury.

Safety precautions and warnings

As the user of this product, you are solely responsible for operating in a manner that does not endanger yourself and others or result in damage to the product or the property of others. This model is controlled by a radio signal subject to interference from many sources outside your control. This interference can cause momentary loss of control so it is advisable to always keep a safe distance in all directions around your model, as this margin will help avoid collisions or injury.

Age Recommendation: Not for children under 14 years. This is not a toy.

- Never operate your model with low transmitter batteries.
- Always operate your model in an open area away from cars, traffic or people.
- Avoid operating your model in the street where injury or damage can occur.
- Never operate the model in populated areas for any reason.
- Carefully follow the directions and warnings for this and any optional support equipment you use (chargers, rechargeable battery packs, etc.)
- Keep all chemicals, small parts and anything electrical out of the reach of children.
- Moisture causes damage to electronics. Avoid water exposure to all equipment not specifically designed and protected for this purpose.
- Never lick or any place of any your model in your mouth as it could cause serious injury or even death.

Safety**Lithium Polymer (Li-Po) Battery Warning**

CAUTION: Always follow the manufacturer's instructions for safe use and disposal of batteries. Fire, property damage, or serious injury can result from the mishandling of Li-Po batteries.

- By handling, charging or using a Li-Po Battery you assume all risks associated with lithium batteries.
 - If at any time the batteries begin to swell or balloon, discontinue use immediately!
 - Always store the batteries at room temperature in a dry area to extend the life of the battery. Always transport or temporarily store the battery in a temperature range of 40-120F. Do not store the battery or model in a car or in direct sunlight. If stored in a hot car, the battery can be damaged or even catch fire.
 - Never use a Ni-Mh Charger to charge Li-Po Batteries. Failure to charge the battery with a Li-Po compatible charger may cause fire resulting in personal injury and property damage.
 - Never discharge Li-Po Cells below 3V.
 - Never leave charging batteries unattended.
 - Never charge damaged batteries.
- Charging the Flight Battery Warning**
- Use a battery charger that is designed to safely charge the Li-Po Battery. Read the charger instructions carefully before use. When charging the battery, make certain the battery is on a heat resistant surface. It is also highly recommended to place the Li-Po Battery inside a fire resistant charging bag readily available at hobby shops or online.

Introduction

There are many choices out there for pure trainers, but for those who want something that serves as a trainer but won't become obsolete after they've learnt to fly- look no further than the new 1280mm Easy Trainer V2!

As a trainer and a glider, the FMS 1280mm Easy Trainer V2 is a plane most pilots can appreciate!

The upgraded 2212-2650KV motor gives fantastic thrust to weight ratio while being very efficient in flight. Expect 6-7 minutes of full-power flight time and up to 20 minutes with proper throttle management!

Thanks to the pusher configuration, the 1280mm Easy Trainer V2 can teach the pilot basic aerobatics with an added safety factor; it's also a great FPV platform as there is no propeller obstructing the view ahead!

Assembled in as little as 5 minutes- the robust airframe is easy to build, repair and will stand up to rough handling with ease.

Can't choose between a glider or a trainer? Why not have both with the FMS 1280mm Easy Trainer V2?

Features:

- Simple, lightweight and robust
- Dual purpose glider/trainer
- Pusher configuration for added safety, great FPV platform
- Vibrant red trim scheme
- Belly lander configuration
- Functional ailerons

Table of contents

Introduction 3

Kit contents 3

Model assembly 4

Battery installation 6

Receiver diagram 6

Get your model ready to fly 6

Clevis installation 8

Control horn and servo arm settings 8

Center of gravity(CG) 8

Before flying the model 9

Flying course 9

Trouble shooting 10

Spare parts list content 10

User Manual of Brushless Speed Controller 11

Kit contents

Before assembly, please inspect the contents of the kit. The photo below details the contents of the kit with labels. If any parts are missing or defective, please identify the name or part number (refer to the spare parts list near the end of the manual) then contact your local shop or email us: support@fmsmodel.com.

Specifications
Wingspan: 1280mm (50.4in)
Overall Length: 910mm (35.8in)
Flying Weight: Around 630g
Motor Size: 2212 - KV2650
Wing Load: 29.4g/dm ² (0.06oz/in ²)
Wing Area: 21.4dm ² (331.5sq.in)
ESC: 20A
Servo: 9g x 4pcs
Recommended Battery: 7.4V 1300mAh 20C

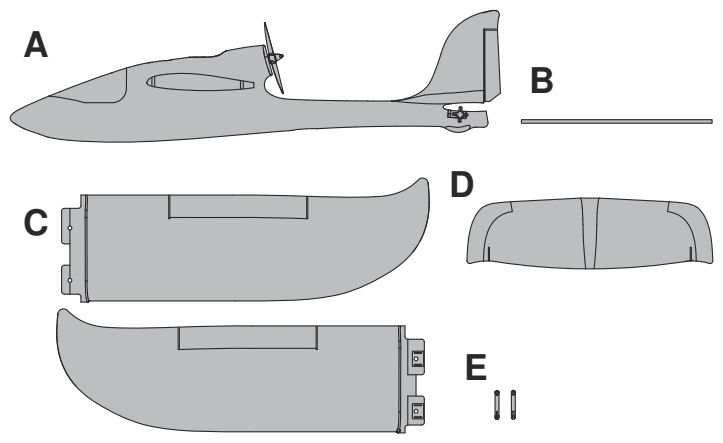

A: Fuselage C: Main wing halves E: Wing alignment pins
 B: Wing spar D: Horizontal stabilizer

Model assembly

Main wing assembly

1. With the aircraft inverted, slide the wing spar into the fuselage as shown.

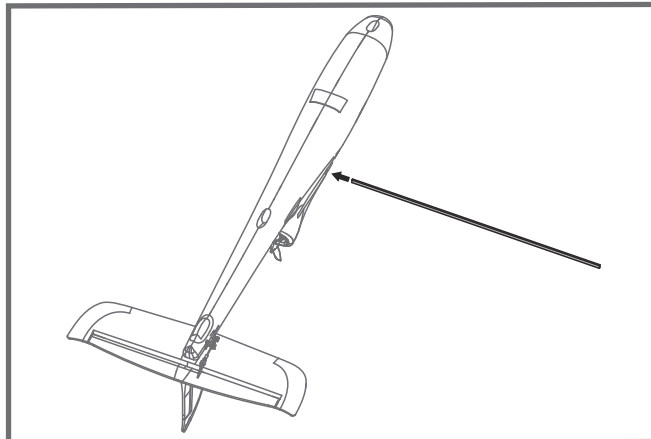

2. Slide the wing halves onto the wing spar and into their fuselage slots.

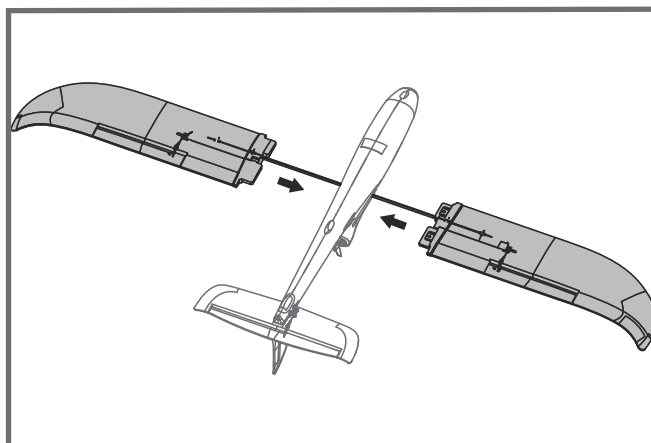

3. Use the wing alignment pins to align and secure the wing halves.

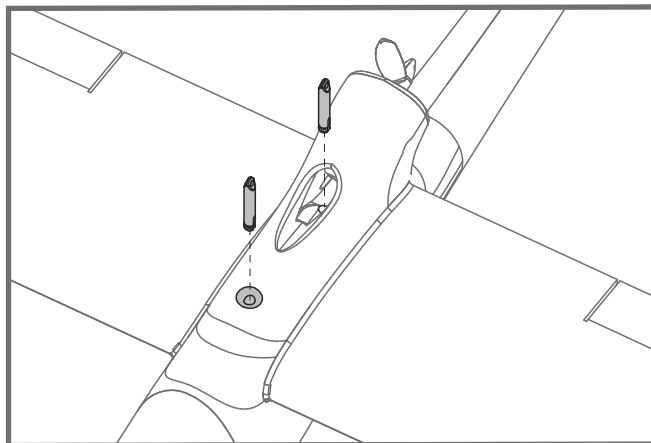

Model assembly

Installation of the horizontal stabilizer

1. Apply glue to the area indicated in the diagram and adhere the horizontal stabilizer to the fuselage.

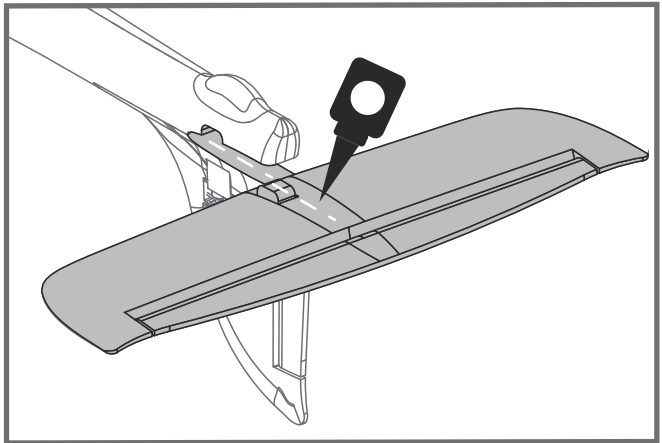
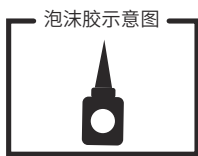

Pushrod installation

1. With the servos centered, connect the pushrod clevis to the control horn of the elevator.

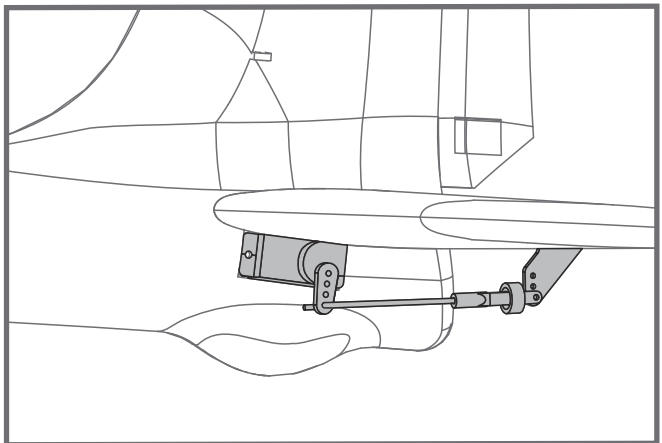

Battery installation

1. Pull back on the latch and remove the battery hatch.
2. Apply the hook tape to the cable end of the battery.
3. Slide the full charged battery into the battery compartment with the power supply cable toward the rear end of the plane.

Note: The center of gravity can be adjusted by moving the battery forward or aft. Having the correct center of gravity is critical to achieving proper flight characteristics.

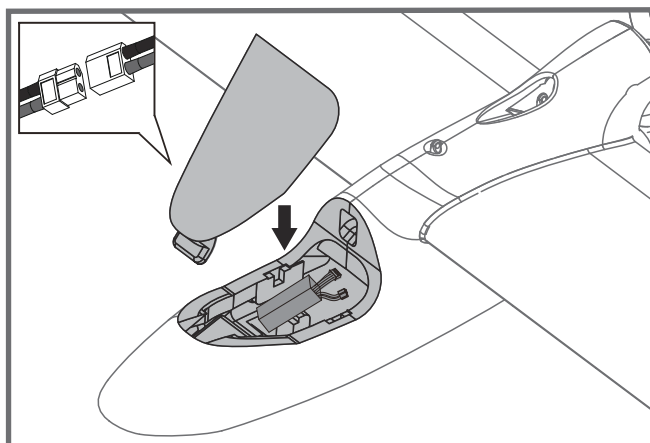

Receiver diagram

The cables from the servo connector board should be connected to your receiver in the order shown. Note that the LEDs can be powered by any spare channel on the receiver. Tuck the wire leads into the recessed cavity towards the rear of the battery hatch.

		Receiver
Aileron	1	Channel-1 — Aile
Elevator	2	Channel-2 — Elev
Throttle	3	Channel-3 — Thro
Rudder	4	Channel-4 — Rudd
Gear	5	Channel-5 — Gear
Spare	6	Channel-6 — Spare

Get your model ready to fly

Important ESC and model information

1. The ESC included with the model has a safe start. If the motor battery is connected to the ESC and the throttle stick is not in the low throttle or off position, the motor will not start until the throttle stick is moved to the low throttle or off position. Once the throttle stick is moved to the low throttle or off position, the motor will emit a series of beeps. Several beeps with the same tune means the ESC has detected the cells of the battery. The count of the beeps equals the cells of the battery. The motor is now armed and will start when the throttle is moved.
2. The motor and ESC come pre-connected and the motor rotation should be correct. If for any reason the motor is rotating in the wrong direction, simply reverse two of the three motor wires to change the direction of rotation.
3. The motor has an optional brake setting. The ESC comes with brake switched off and we recommend that the model be flown with the brake off. However, the brake could be accidentally switched on if the motor battery is connected to the ESC while the throttle stick is set at full throttle. To switch the brake off, move the throttle stick to full throttle and plug in the motor battery. The motor will beep one time. Move the throttle stick to low throttle or the off position. The motor is ready to run and the brake will be switched off.
4. Battery Selection and Installation. We recommend the 7.4V 1300mAh 20C Li-Po battery. If using another battery, the battery must be at least a 7.4V 1300mAh 20C battery. Your battery should be approximately the same capacity, dimension and weight as the 7.4V 1300mAh 20C Li-Po battery to fit the fuselage without changing the center of gravity significantly.

Transmitter and model setup

Before getting started, bind your receiver with your transmitter. Please refer to your transmitter manual for proper operation.
CAUTION: To prevent personal injury, DO NOT install the propeller assembly onto the motor shaft while testing the control surfaces. DO NOT arm the ESC and do not turn on the transmitter until the Transmitter Manual instructs you to do so.
 Tips: Make sure all control sticks on your radio are in the neutral position (rudder, elevator, ailerons) and the throttle is in the OFF position. Make sure both ailerons move up and down (travel) the same amount. This model tracks well when the left and right ailerons travel the same amount in response to the control stick. Move the controls on the transmitter to make sure the aircraft control surface moves correctly. See diagrams right.

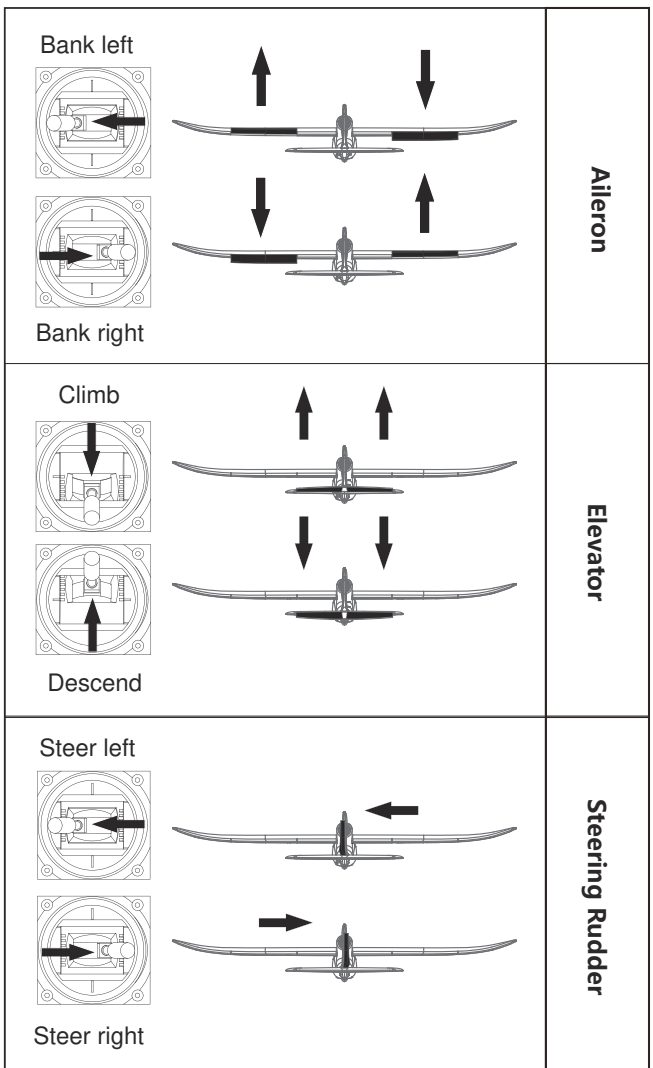

Control throws

The suggested control throw setting for the 1280mm Easy trainer V2 are as follows (dual rate setting):

Tips: On the first flight, fly the model in low rate. The first time you use high rates, be sure to fly at low to medium speeds. High rate, as listed, is only for EXTREME maneuvering.

	High Rate	Low Rate
Elevator	20mm up / down	16mm up / down
Aileron	18mm up / down	14mm up / down
Rudder	24mm left / right	20mm left / right

Clevis installation

1. Pull the tube from the clevis to the linkage.
2. Carefully spread the clevis, then insert the clevis pin into the desired hole in the control horn.
3. Move the tube to hold the clevis on the control horn.

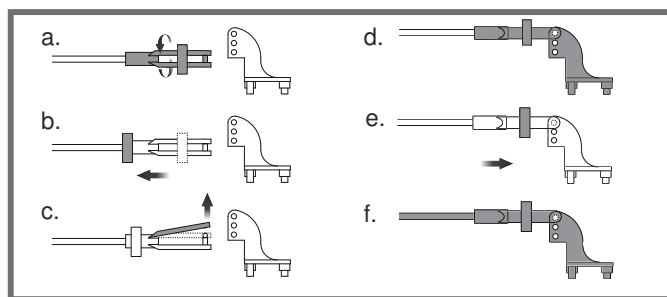

Control horn and servo arm settings

The table shows the factory settings for the control horns and servo arms. Fly the aircraft at the factory settings before making changes. After flying, you may choose to adjust the linkage positions for the desired control response.

	Horns	Arms	More control throw
Elevator			
Rudder			
Ailerons			
			Less control throw

Check the C.G. (Center of gravity)

When balancing your model, adjust the battery as necessary so the model is level or slightly nose down. This is the correct balance point for your model. After the first flight, the CG position can be adjusted for your personal preference.

1. The recommended Center of Gravity (CG) location for your model is (65-75mm) from the leading edge of the main wing (as shown) with the battery pack installed. Mark the location of the CG on top of the wing.
2. When balancing your model, support the plane at the marks made on the bottom of the main wing with your fingers or a commercially available balancing stand. This is the correct balance point for your model. Make sure the model is assembled and ready for flight before balancing.

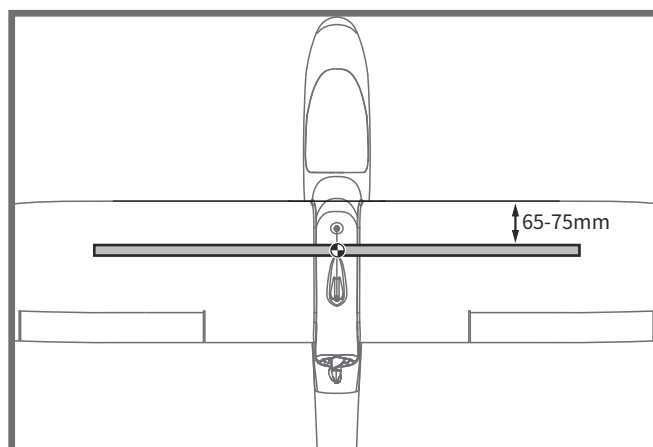

Before flying the model

Find a suitable flying site

Find a flying site clear of buildings, trees, power lines and other obstructions. Until you know how much area will be required and have mastered flying your plane in confined spaces, choose a site which is at least the size of two to three football fields - a flying field specifically for R/C planes is best. Never fly near people - especially children, who can wander unpredictably.

Perform the range check for your plane

As a precaution, an operational ground range test should be performed before the first flight each time you go out. Performing a range test is a good way to detect problems that could cause loss of control such as low batteries, defective or damaged radio components, or radio interference. This usually requires an assistant and should be done at the actual flying site you will be using.

First turn on the transmitter, then install a fully-charged battery into the fuselage. Connect the battery and install the hatch.

Remember, use care not to bump the throttle stick. Otherwise, the propeller/fan will turn and possibly cause damage or injury.

Note: Please refer to your Transmitter Manual that came with your radio control system to perform a ground range check. If the controls are not working correctly or if anything seems wrong, do not fly the model until you correct the problem. Make certain all the servo wires are securely connected to the receiver and the transmitter batteries have a good connection.

Monitor your flight time

Monitor and limit your flight time using a timer (such as on a wristwatch or in your transmitter if available). When the batteries are getting low you will usually notice a performance drop before the ESC cuts off motor power, so when the plane starts flying slower you should land. Often (but not always) power can be briefly restored after the motor cuts off by holding the throttle stick all the way down for a few seconds. To avoid an unexpected dead-stick landing on your first flight, set your timer to a conservative 4 minutes. When your alarm sounds you should land right away.

Flying course

Take off

While applying power, slowly steer to keep the model straight. The model should accelerate quickly. As the model gains flight speed you will want to climb at a steady and even rate. It will climb out at a nice angle of attack (AOA).

Flying

Always choose a wide-open space for flying your plane. It is ideal for you to fly at a sanctioned flying field. If you are not flying at an approved site always avoid flying near houses, trees, wires and buildings. You should also be careful to avoid flying in areas where there are many people, such as busy parks, schoolyards, or soccer fields. Consult laws and ordinances before choosing a location to fly your aircraft. After takeoff, gain some altitude. Climb to a safe height before trying technical manoeuvres, including high speed passes, inverted flight, loops, and point rolls.

Landing

Land the model when you hear the motor pulsing (LVC) or if you notice a reduction in power. If using a transmitter with a timer, set the timer so you have enough flight time to make several landing approaches. The model's three point landing gear allows the model to land on hard surfaces. Align model directly into the wind and fly down to the ground. Fly the airplane down to the ground using 1/4-1/3 throttle to keep enough energy for proper flare. Before the model touches down, always fully decrease the throttle to avoid damaging the propeller or other components. The key to a great landing is to manage the power and elevator all the way to the ground and set down lightly on the main landing gear. After a few flights you will find the model can be set down lightly on the mains and you can hold the nose wheel off balancing the model on the mains until it slows and gently settles the nose.

Maintenance

Repairs to the foam should be made with foam safe adhesives such as hot glue, foam safe CA, and 5min epoxy. When parts are not repairable, see the Spare Parts List for ordering by item number. Always check to make sure all screws on the aircraft are tightened. Pay special attention to make sure the spinner is firmly in place before every flight.

Trouble shooting

Problem	Possible Cause	Solution
Aircraft will not respond to the throttlebut responds to other controls.	-ESC is not armed. -Throttle channel is reversed.	-Lower throttle stick and throttle trim to lowest settings. -Reverse throttle channel on transmitter.
Extra propeller noise or extra vibration.	-Damaged spinner, propeller, motor or motor mount. -Loose propeller and spinner parts. -Propellor installed backwards.	-Replace damaged parts. -Tighten parts for propeller adapter, propeller and spinner. -Remove and install propeller correctly.
Reduced flight time or aircraft underpowered.	-Flight battery charge is low. -propeller installed backward. -Flight battery damaged.	-Completely recharge flight battery. -Replace flight battery and follow flight battery instructions.
Control surface does not move, or is slow to respond to control inputs.	-Control surface, control horn, linkage or servo damage. -Wire damaged or connections loose.	-Replace or repair damaged parts and adjust controls. -Do a check of connections for loose wiring.
Controls reversed.	Channels are reversed in the transmitter.	Do the control direction test and adjust controls for aircraft and transmitter.
-Motor loses power -Motor power pulses then motor loses power.	-Damage to motor, or battery. -Loss of power to aircraft. -ESC uses default soft Low Voltage Cutoff(LVC).	-Do a check of batteries, transmitter, receiver, ESC, motor and wiring for damage(replace as needed). -Land aircraft immediately and recharge flight battery.
LED on receiver flashes slowly.	Power loss to receiver.	-Check connection from ESC to receiver. -Check servos for damage. -Check linkages for binding.

Spare parts list content

FMSSQ101-1	Fuselage
FMSSQ102-1	Main Wing
FMSSQ103-1	Horizontal Stabilizer
FMSSQ104-1	Canopy
FMSSQ107-1	Linkage Rods
FMSSQ109	Sticker
FMSSQ115	Pipe
FMSPROP043	Propeller
FMSDJ020	Motor Mount
FMSBM043	Motor Board
PRKV2650-S	Motor
PRESC004	ESC
FMS9GDP	9g Servo
FMSCHR01	Charger

Visit our website: www.fmsmodel.com to see photo of this product. Enter the key word "ESC" in the search bar for the stock ESC instruction manual.

User Manual of Brushless Speed Controller

Thanks for purchasing our Electronic Speed Controller (ESC). High power system for RC model is very dangerous, please read this manual carefully. In that we have no control over the correct use, installation, application, or maintenance of our products, no liability shall be assumed nor accepted for any damages, losses or costs resulting from the use of the product. Any claims arising from the operating, failure or malfunctioning etc. will be denied. We assume no liability for personal injury, property damage or consequential damages resulting from our product or our workmanship. As far as is legally permitted, the obligation to compensation is limited to the invoice amount of the affected product.

Specifications

Model	Cont Current	Burst Current (≤10)	BEC Mode	BEC Output	BEC Output Capability				Battery Cell		Weight	Weight
					2S Lipo	3S Lipo	4S Lipo	6S Lipo	Lipo	NiMH		L*W*H (mm)
6A	6A	8A	Linear	5V/0.8A	3servos				2S	5-6 cells	5.5	32*12*4.5
12A	12A	15A	Linear	5V/1A	3servos	2servos			2-3S	5-9 cells	9g	38*18*6
12AE	12A	15A	Linear	5V/2A	5servos	4servos			2-3S	5-9 cells	10g	38*18*7
15A	15A	20A	Linear	5V/2A	5servos	4servos			2-3S	5-9 cells	16.5g	48*22.5*6
20A	20A	25A	Linear	5V/2A	5servos	4servos			2-3S	5-9 cells	19g	42*25*8
30A	30A	40A	Linear	5V/2A	5servos	4servos			2-3S	5-9 cells	37g	68*25*8
40A	40A	55A	Linear	5V/3A	5servos	4servos			2-3S	5-9 cells	39g	68*25*8
40A-UBEC	40A	55A	Switch	5V/3A	5servos	5servos	5servos		2-4S	5-12 cells	43g	65*25*12
50A-UBEC	50A	65A	Switch	5V/5A	8servos	8servos	6servos	6servos	2-4S	5-12 cells	41g	65*29*10
60A-UBEC	60A	80A	Switch	5V/5A	8servos	8servos	6servos	6servos	2-6S	5-18 cells	63g	77*35*14
60A-UBEC	60A	80A	N/A	N/A					2-6S	5-18 cells	60g	86*38*12
80A-UBEC	80A	100A	Switch	5V/5A	8servos	8servos	6servos	6servos	2-6S	5-18 cells	82g	86*38*12
80A-UBEC	80A	100A	N/A	N/A					2-6S	5-18 cells	79g	86*38*12

Programmable Items (The option written in bold font is the default setting)

1. Brake Setting: Enabled / **Disabled**
2. Battery Type: **Lipo** / NiMH
3. Low Voltage Protection Mode(Cut-Off Mode): **Soft Cut-Off (Gradually reduce the output power)** /Cut-Off (Immediately stop the output power).
4. Low Voltage Protection Threshold(Cut-Off Threshold): Low / **Medium** / High
 - 1) For lithium battery, the battery cell number is calculated automatically. Low / medium / high cutoff voltage for each cell is 2.85V/3.15V/3.3V. For example: For a 3S Lipo, when "Medium" cutoff threshold is set, the cut-off voltage will be:3.15*3=9.45V.
 - 2) For NiMH battery, low / medium / high cutoff voltages are 0%/50%/65% of the startup voltage (i.e. the initial voltage of battery pack), and 0% means the low voltage cut-off function is disabled. For example: For a 6 cells NiMH battery, fully charged voltage is 1.44*6=8.64V, when "Medium"cut-off threshold is set, the cut-off voltage will be: 8.64*50%=4.32V.
5. Startup Mode: **Normal** /Soft /Super-Soft (300ms / 1.5s / 3s)
 - a) Normal mode is suitable for fixed-wing aircraft. Soft or Super-soft modes are suitable for helicopters. The initial acceleration of the Soft and Super-Soft modes are slower, it takes 1.5 second for Soft startup or 3 seconds for Super-Soft startup from initial throttle advance to full throttle. If the throttle is completely closed (throttle stick moved to bottom position) and opened again (throttle stick moved to top position) within 3 seconds after the first startup, the re-startup will be temporarily changed to normal mode to get rid of the chance of a crash caused by slow throttle response. This special design is suitable for aerobatic flight when quick throttle response is needed.
6. Timing: **Low** / Medium / High,(3.75°/15°/26.25°) Usually, low timing is suitable for most motors. To get higher speed, High timing value can be chosen.

User Manual of Brushless Speed Controller

Begin To Use Your New ESC

IMPORTANT! Because different transmitter has different throttle range, please calibrate throttle range before flying.

Throttle range setting (Throttle range should be reset whenever a new transmitter is being used)

1. Switch on the transmitter, move throttle stick to the top position.
2. Connect battery pack to the ESC, and wait for about 2 seconds.
3. The "Beep-Beep-" tone should be emitted, means the top point of throttle range has been confirmed.
4. Move throttle stick to the bottom position, several "beep-" tones should be emitted to present the amount of battery cells.
5. A long "Beep-" tone should be emitted, means the lowest point of throttle range has been correctly confirmed.

Normal startup procedure

1. Move throttle stick to bottom position and then switch on transmitter.
2. Connect battery pack to ESC, special tone like "♪ 123" means power supply is OK.
3. Several "beep-" tones should be emitted to present the amount of lithium battery cells.
4. When self-test is finished, a long "beep-----" tone should be emitted.
5. Move throttle stick upwards to go flying.

Protection Function

1. Start up failure protection: If the motor fails to start within 2 seconds of throttle application, the ESC will cut-off the output power. In this case, the throttle stick **MUST** be moved to the bottom again to restart the motor. (Such a situation happens in the following cases: The connection between ESC and motor is not reliable, the propeller or the motor is blocked, the gearbox is damaged, etc.)
2. Over-heat protection: When the temperature of the ESC is over about 110 Celsius degrees, the ESC will reduce the output power.
3. Throttle signal loss protection: The ESC will reduce the output power if throttle signal is lost for 1 second, further loss for 2 seconds will cause the output to be cut-off completely.

Trouble Shooting

Trouble	Possible Reason	Action
After power on, motor does not work, no sound is emitted	After power on, motor does not work, no sound is emitted	Check the power connection. Replace the connector.
After power on, motor does not work, such an alert tone is emitted: "beep-beep-, beep-beep-,beep-beep-" (Every "beep-beep-" has a time interval of about 1 second)	Input voltage is abnormal, too high or too low	Check the voltage of battery pack
After power on, motor does not work, such an alert tone is emitted: "beep-, beep-, beep- "(Every "beep-" has a time interval of about 2 seconds)	Throttle signal is irregular	Check the receiver and transmitter Check the cable of throttle channel
After power on, motor does not work, such an alert tone is emitted: "beep-, beep-, beep- "(Every "beep-" has a time interval of about 0.25 second)	The throttle stick is not in the bottom (lowest) position	Move the throttle stick to bottom position
After power on, motor does not work, a special tone "♪56712" is emitted after 2 beep tone (beep-beep-)	Direction of the throttle channel is reversed, so the ESC has entered the program mode	Set the direction of throttle channel correctly
The motor runs in the opposite direction	The connection between ESC and the motor need to be changed	Swap any two wire connections between ESC and motor

Program the ESC with your transmitter (4 Steps)

Note: Please make sure the throttle curve is set to 0 when the throttle stick is at bottom position and 100% for the top position.

NO.1 Enter program mode

1. Switch on transmitter, move throttle stick to top position, connect the battery pack to ESC
2. Wait for 2 seconds, the motor should emit special tone like "beep-beep-"
3. Wait for another 5 seconds, special tone like "♪56712" should be emitted, which means program mode is entered.

NO.2 Select programmable items

After entering program mode, you will hear 8 tones in a loop with the following sequence. If you move the throttle stick to bottom within 3 seconds after one kind of tones, this item will be selected.

Prompt tone	Selected item
"beep"(1 short tone)	brake
"beep-beep-"(2 short tone)	battery type
"beep-beep-beep-"(3 short tone)	cutoff mode
"beep-beep-beep-beep-"(4 short tone)	cutoff threshold
"beep——"(1 long tone)	startup mode
"beep——beep-"(1 long 1 short)	timing
"beep——beep-beep-"(1 long 2 short)	set all to default
"beep——beep——"(2 long tone))	exit

Note: 1 long "beep-----" = 5 short "beep-"

NO.3 Set item value (Programmable value)

You will hear several tones in loop. Set the value matching to a tone by moving throttle stick to top when you hear the tone, then a special tone "♪1515" emits, means the value is set and saved. (Keeping the throttle stick at top, you will go back to Step 2 and you can select other items; or moving the stick to bottom within 2 seconds will exit program mode directly) .

Tones	"beep-" 1 short tone	"beep-beep-" 2 short tones	"beep-beep-beep" 3 short tones
Brake	Off	On	
Battery type	Lipo	NiMH	
Cutoff mode	Soft-Cut	Cut-Off	
Cutoff threshold	Low	Medium	High
Start mode	Normal	Soft	Super soft
Timing	Low	Medium	High

NO.4 Exit program mode

There are 2 ways to exit program mode:

1. In step 3, after special tone " ", please move throttle stick to the bottom position within 2 seconds.
2. In step 2, after tone "beep-----beep-----"(that is: The item #8),move throttle stick to bottom within 3 seconds.

警告

警告:在组装、调整及飞行前请务必认真阅读产品说明书以熟知产品的特性。请严格按照说明书提示进行飞机的组装、调整及飞行。如操作不当会造成产品本身损坏及其它财产损失,甚至造成严重的人身伤害。

声明:模型不是玩具,具有一定的危险性,操作者需要具备一定的飞行经验,初学者请在专业人士指导下操作。禁止十四岁以下儿童操作、飞行。

安全须知

本产品飞行由无线电遥控器控制,在飞行过程中可能会受到外界强信号源干扰而导致失控,甚至坠机。因此,在飞行过程中务必始终与飞机保持一定的安全距离,避免意外碰撞、受伤。

- 请勿在发射器电池低电量的情况下操纵模型飞机。
- 请勿在公路、人群、高压线密集区、机场附近及其它法律法规明确禁止飞行的场合飞行。
- 请勿在雷雨、大风、大雪或者其它恶劣气象环境下飞行。
- 请严格遵照产品指导说明及安全警告操作本产品及其相关配置(例如充电器、电池等)。
- 请勿将相关化工类产品、零部件、电子部件等置于儿童可触及的范围。
- 请勿将电子件暴露于潮湿的环境中,以免造成损坏。
- 请勿将本品任意处置于口中,以免造成人身伤亡。

锂聚合物电池使用安全须知

- 使用锂聚合物电池时,须严格遵守制造商说明、要求并了解相关风险,使用不当会导致锂聚合物电池起火,从而造成严重的财产损失甚至人身伤害。
- 禁止使用变形、胀气的锂聚合物电池。
- 禁止使用过充、放电的锂聚合物电池,避免发生危险。长时间不使用须将锂聚合物电池放电至存储电压(3.8~3.85V/节)。锂聚合物电池须储存在室内干燥区域(4.5~48.5°C),禁止将锂聚合物电池置于阳光下暴晒或车内,高温可能会导致锂聚合物电池起火,造成财产损失和人身伤害。
- 请使用专用充电器对锂聚合物电池进行充放电,禁止使用其它如:镍氢电池充电器。充放电时,禁止将锂电池放置于高温物体表面,建议使用锂电池防爆袋。不正确的充放电操作会对锂聚合物电池造成损伤,甚至会引起火灾,造成财产损失和人身伤害。
- 禁止将锂聚合物电池单节电压放至低于3V,禁止给已损坏的锂聚合物电池充电。
- 锂聚合物电池充放电须在有人看管的情况下进行,避免发生意外造成不必要的损失。

飞机电池充电警告:

请确保使用合格的电池充电器给锂电池充电。在使用充电器前,请认真阅读充电器说明书。充电过程中,请确保把电池置于耐热的表面。建议把锂电池置于防火充电袋内充电,防火充电袋可在相关模型实体店或网上买到。

产品特点

如果你想要一架纯粹的初学者飞机，那你会有很多选择，但如果你想在有限的预算和飞行水平条件下，体验更多可能，一定不要错过 FMS 这款全新升级的 1280mm Easy Trainer V2。

FMS 1280mm Easy Trainer V2 既是一款训练机，也是一款滑翔机。它兼具出色的滑翔性能和特技性能。滑翔性能可显著延长飞行时间，在全油门的情况下，飞行时间约在 6 或 7 分钟，而在收油滑翔飞行情况下，飞行时间最长可达 20 分钟。特技性能可作为飞手进阶的“基石”，这架飞机虽然身量小小，但可打圈、横滚和倒转飞行。值得一提的是，除非将飞机完全倒置，否则几乎不可能破坏背推的螺旋桨。此外，背推桨的设计也便利 FPV 玩法。

整架飞机结构非常简单，只需 5 分钟即可完成组装。其腹部着陆的设计使初学者可以轻松在草地或其他柔软表面上练习起降。

在 V1 的基础上，V2 电机升级为 2212-KV2650，新的电机配合原有电子配件，更臻完善地平衡飞机的两种性能。此外，涂装由低调的橘色变更为炽热的红色，使之不论在天际还是地面，都能 C 位夺人眼球。

在训练机和滑翔机之间举棋不定？FMS 1280mm Easy Trainer V2，鱼与熊掌亦可兼顾。

特征：

- 简单、轻量、便捷设计
- 兼顾训练机性能与滑翔机性能
- 背推螺旋桨，便利FPV第一视角玩法
- 全新红色涂装
- 腹部着陆设计
- 副翼功能

目录

产品特点	15
产品组成	15
机体安装	16
电池安装	18
接收机连接示意图	18
遥控器设置	19
夹头安装方式	20
舵角和舵机摇臂安装	20
重心调整	20
飞行前准备	21
故障检修指导	22
配件列表	22
电调说明	23

产品组成

在组装产品之前，请仔细检查以下配件，如有缺失或者损坏，请及时联系当地店面或者邮件至厂家 (support@fmsmodel.com)，告知缺失或损坏的配件名称及编码（请在本说明书尾页查看相应的配件编码）。请注意，不同配置，包装盒内部物品不同。

产品参数

翼展: 1280mm (50.4in)
机身长: 910mm (35.8in)
飞行重量: ~ 630g
电机: 2212-KV2650
翼载荷: 29.4g/dm ² (0.06oz/in ²)
翼面积: 21.4dm ² (331.5sq.in)
电调: 20A
舵机: 9g x 4pcs
电池: 7.4V 1300mAh 20C

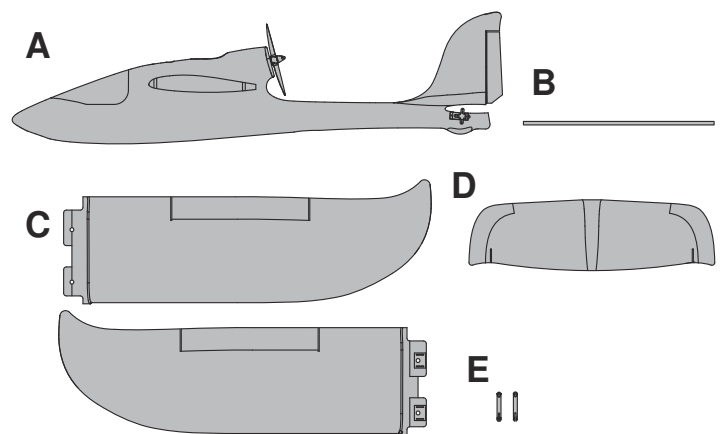

A: 机身 C: 主翼 E: 插销
 B: 主翼对接管 D: 平尾

机体安装

主翼安装

1. 如图所示，保持机身底部朝上，将主翼对接管安装至机身槽位。

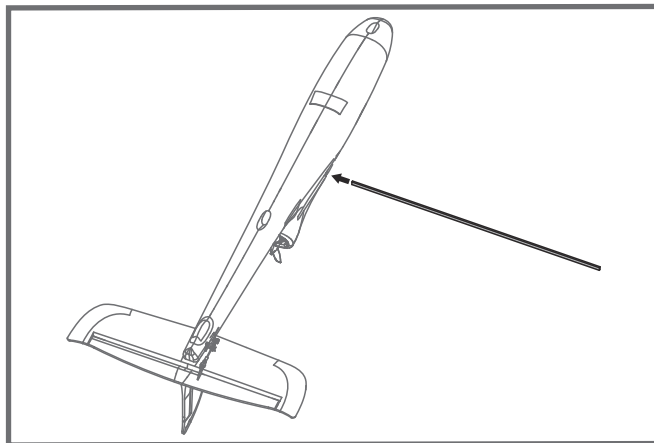

2. 将左右两侧主翼安装至主翼对接管，往机身方向移动合拢主翼。

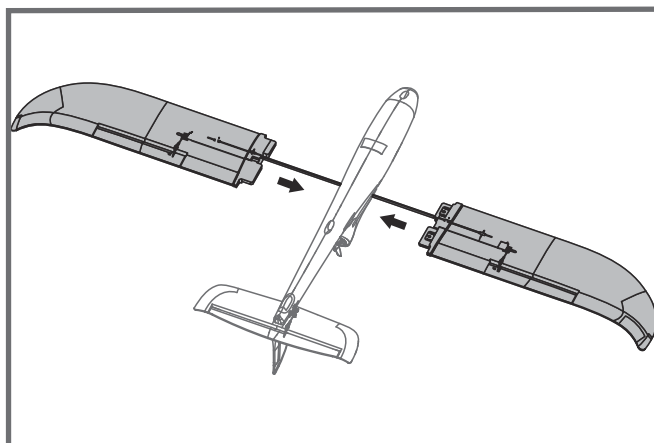

3. 使用插销固定主翼。

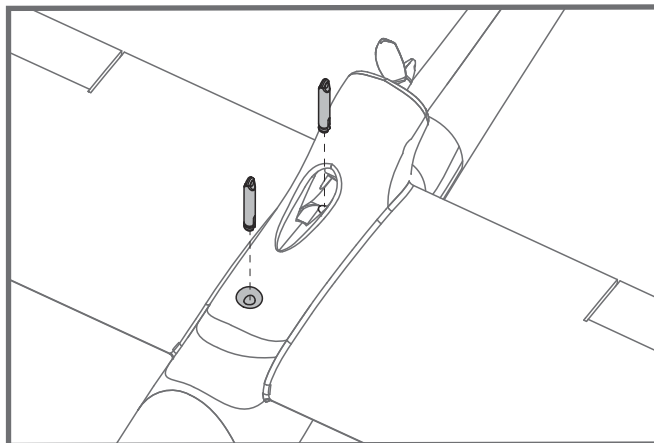

机体安装

平尾安装

1. 在图示位置打胶,将平尾安装至机身尾部槽位。

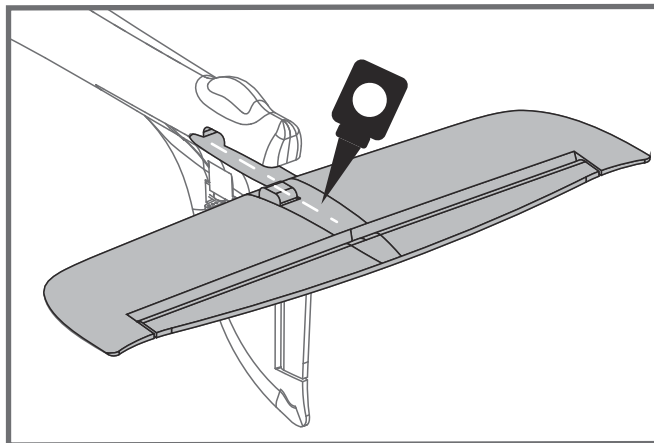
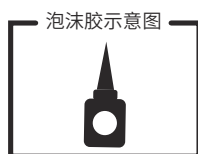

连接钢丝安装

1. 如图所示,保持舵机回中状态,将连接钢丝安装至平尾舵机摇臂。

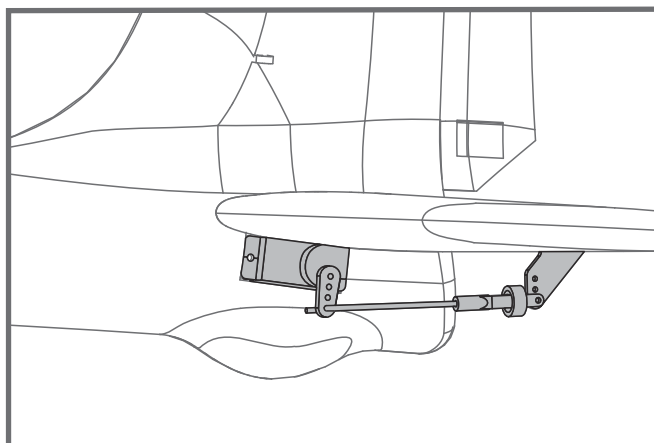

电池安装

1. 移开电池盖。
2. 取下电池板上的魔术贴(毛面)贴于电池表面。
3. 如图所示,将电池置于电池舱内,用魔术带绑紧,使有电源线的那端朝向飞机的尾部。

注意: 由于不同电池厂家生产的电池重量有轻微的差异, 需要调整电池的前后位置来平衡飞机的重心位置。

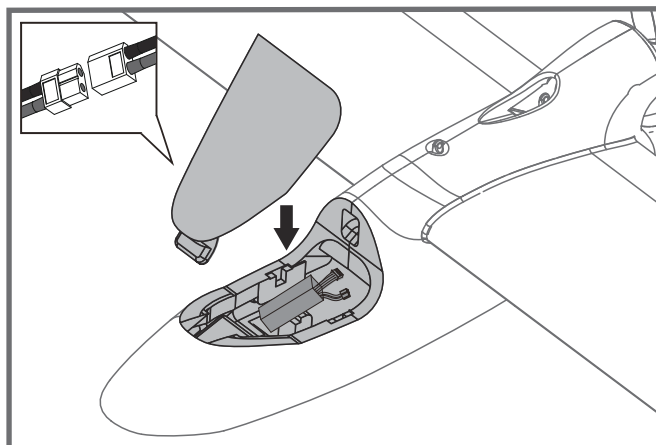

接收机连接示意图

如图所示, 以 Futaba 遥控器为例, 将副翼舵机信号线插入接收机副翼通道、升降舵舵机信号线插入接收机升降舵通道、方向舵舵机信号线插入接收机方向舵通道、电调信号线插入接收机油门通道。最后将所有连接线整理整齐并固定在电池仓后部的凹槽内, 随后固定好接收机。

请注意, 如产品带有襟翼功能, 则将襟翼舵机信号线插入接收机的襟翼通道(6CH)。如产品配有LED, 则LED信号线可插入任何闲置通道。

		Receiver
副翼	1	Channel-1 — Aile
平尾	2	Channel-2 — Elev
油门	3	Channel-3 — Thro
垂尾	4	Channel-4 — Rudd
起落架	5	Channel-5 — Gear
其他通道	6	Channel-6 — Spare

遥控器设置

警告：为保证安全，在遥控器参数设置及舵面调整过程中，请务必拆下螺旋桨，以免电机意外启动发生事故。遥控器发射机开机前，确保油门杆在最低位置，其它摇杆在中立位置。开发射机并给接收机通电，随后听到电调初始化音（音符释义见后文“电调说明书”）。观察所有舵面是否回中，如果没有回中，尽量通过调整舵机摇臂角度、连杆长度的方式来使舵面回中，若调整长度在安全范围内仍未回中，则使用遥控器通道微调或者菜单中的“Sub Trim”选项来使舵面归中。如下图所示观察摇杆动作与舵面动作的对应关系，如发生舵面反向需要使用遥控器中的通道反向功能来纠正。

1. 移动发射器上的控制杆位置，确保舵面可以自如移动。

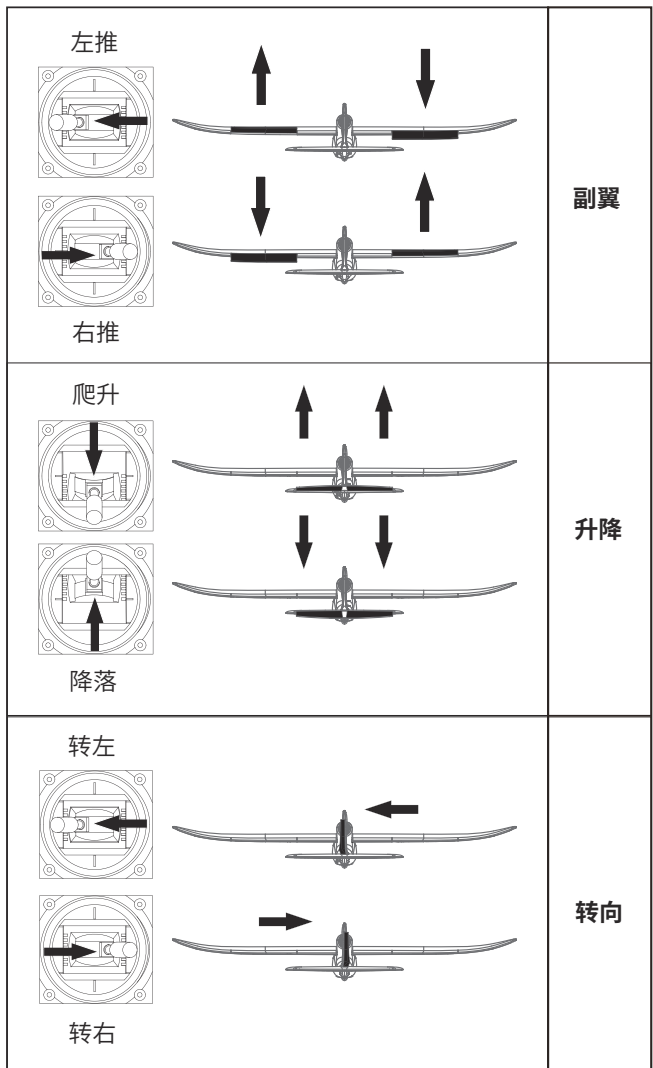

推荐舵面行程

温馨提示：首飞建议用小舵面行程

	大	小
升降舵	20mm up / down	16mm up / down
副翼舵	18mm up / down	14mm up / down
方向舵	24mm left / right	20mm left / right

夹头安装方式

1. 保证舵机为回中状态，将连接杆夹头调整到合适位置。
2. 将 O 型圈移开，打开夹头，将夹头安装到舵角孔位。
3. 将 O 型圈移回相应位置，锁紧夹头。

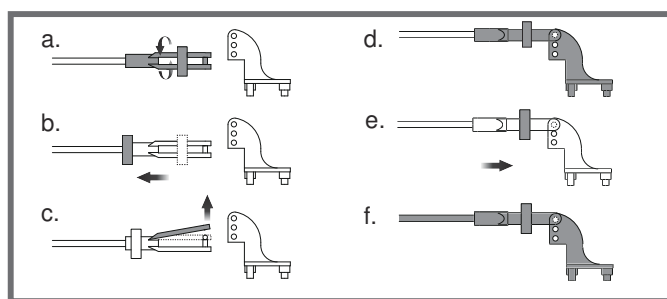

舵角和舵机摇臂安装

图示是舵角和舵面摇臂的出厂设置。首飞建议用出厂设置的舵角飞行。首飞后，可按图调整舵角。

	舵角	摇臂	大舵面
平尾			
垂尾			
副翼			小舵面

重心调整

通过移动电池在电池舱内的前后位置调整飞机的重心，使飞机保持水平或稍微头重的状态。首飞以后，重心位置可以根据你自己的飞行偏好再做更改。

1. 如图所示，推荐重心位置是机翼前缘往后 65-75mm 处（安装电池以后）。推荐把食指放在机翼下面的重心位置来帮助调整重心。
2. 在调整飞机重心的时候请确定飞机处于组装完毕待飞的状态。

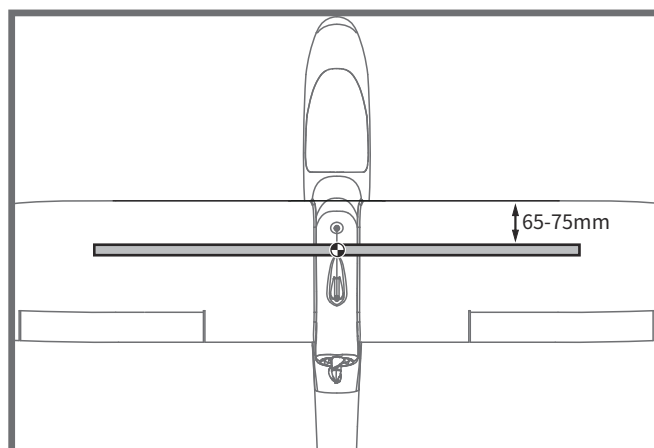

飞行前准备

起飞前的检查

每次飞行前须做严格的地面检查,可有效避免飞行事故的发生。

1. 检查全机螺丝是否安装到位、舵角摇臂连接可靠。机翼快拆装置已锁紧。
2. 安装电池,并调整飞机重心到说明书推荐位置。
3. 动力电池、遥控器发射机电池等已充满电,处于可靠工作状态。
4. 发射机油门杆保持在最低位(推荐使用带有油门锁定功能的遥控设备),打开发射机,随后连接动力电池,待电调初始化完成后检查各个舵面是否回中,是否动作正确。
5. 轻推油门观察螺旋桨转向是否正确。

所有检查完成后,方可进行飞行,初学者首次飞行需要有经验的爱好者协助完成,避免因操作不当发生飞行事故。

合适的飞行场地

航模飞行须远离人群、建筑物、树木、高压线及禁飞区的空旷场地(至少 2-3 个足球场大小)。初学者飞行前需要向有经验的爱好者询问相关安全事宜。

关于飞行时间

厂家推荐的飞行时间是使用厂家推荐型号的电池,由有经验的爱好者在微风天完成飞行测试得到的飞行时间,该时间与电池参数、飞机全备重量、飞行条件以及飞行手法相关,不同飞行条件可能得到不同的飞行时间。

建议爱好者在飞行时使用遥控器的“计时功能”,建议初始飞行时间设定为 4 分钟,飞行时间倒计时告警后,降落飞机并测量电池电压,方可估算飞行时间并重新调整遥控器计时。如发射机没有计时功能,需要其他设备辅助测算飞行时间,以保证飞行安全。在电池放电后期,禁止将飞机飞入下风区(风向指向的远端),防止动力不足而导致飞机不能安全返航。

故障检修指导

问题	问题原因	解决方式
油门推杆无响应,但舵机有响应	<ul style="list-style-type: none"> —电调未连接电机 —油门通道反向 	<ul style="list-style-type: none"> —降低油门推杆和油门微调设定 —反过来重新装油门通道
桨的噪音过大或者震动过大	<ul style="list-style-type: none"> —桨罩、桨、电机、电机架坏了 —桨或者桨罩的小部件松动了 —桨装反了 	<ul style="list-style-type: none"> —更换损坏的配件 —把桨、桨夹和桨罩的小部件拧紧 —反过来重新装桨
飞行时间变短,飞机无力	<ul style="list-style-type: none"> —电池电量低 —桨装反了 —电池坏了 	<ul style="list-style-type: none"> —重新给电池充电 —依照电池说明书更换新的电池
飞舵面不动,或者动作响应较慢	<ul style="list-style-type: none"> —舵面、舵角、连接杆、舵机坏了 —连接线坏了或者接头松了 	<ul style="list-style-type: none"> —更换或者维修坏了的配件 —检查所有连接线,确保所有接头无松动现象
舵面反向	<ul style="list-style-type: none"> —遥控器发射机通道反向 	<ul style="list-style-type: none"> —检查通道控制(舵面)方向,调试飞机舵面和遥控器的舵面控制杆
电机无力	<ul style="list-style-type: none"> —电机或电池坏了 —电调用了不合适的低压保护装置 	<ul style="list-style-type: none"> —检查电池、发射机、接收机、电调、电机是否有损坏(如有,请及时更换) —立刻操控飞机降落,重新给电池充电
接收器的LED灯慢闪	<ul style="list-style-type: none"> —接收器低电量 	<ul style="list-style-type: none"> —检查电调和接收器之间的连接 —检查舵机是否受损 —检查连接杆是否安装到位

配件列表

FMSSQ101-1	机身
FMSSQ102-1	主翼
FMSSQ103-1	平尾
FMSSQ104-1	座舱组
FMSSQ107-1	连接杆
FMSSQ109	贴纸(红色)
FMSSQ115	对接管
FMSPROP043	桨
FMSDJ020	电机架
FMSBM043	电机板
PRKV2650-S	KV2650电机
PRESC004	20A电调
FMS9GDP	9克塑胶正向舵机
FMSCHR01	充电器

如需查找产品图片,请登录FMS官方淘宝店<https://fmsmodel.taobao.com>。如需查找电调说明书,则在以上网址搜索栏中搜索关键词“电调”,即可在任何一款电调产品页面查看。

电调使用说明

感谢您购买本产品!无刷动力系统功率强大,错误的使用可能造成人身伤害和设备损坏。为此我们强烈建议您在使用设备前仔细阅读本说明书,并严格遵守规定的操作程序。我们不承担因使用本产品或擅自对产品进行改造所引起的任何责任,包括但不限于对附带损失或间接损失的赔偿责任。

产品特点

1. 所有器件均为原装正品,确保电调具有一流品质和极高的可靠性。
2. 具有强大的耐流能力。
3. 具备输入电压异常保护、电池低压保护、过热保护、油门信号丢失保护等多重保护功能。
4. 具有普通启动、柔和启动、超柔和启动三种启动模式,兼容固定翼飞机及直升机。
5. 可设定油门行程,兼容各种遥控器。具备平滑、细腻的调速手感,一流的调速线性。
6. 最高转速可达 210000 RPM (2 极马达)、70000 RPM (6 极马达)、35000 RPM (12 极马达)。

产品功能简要说明(粗体字为出厂默认值)

1. 刹车设定: **无刹车** / 有刹车。
2. 电池类型: **Lipo (锂电池)** / NiMH (镍氢)。
3. 电池低压保护模式: **逐渐降低功率** / 立即关闭输出。
注: 低压保护时,将油门摇杆拉到最小油门的位置后即可重新启动马达,但因为此时仍处于低压状况,所以功率输出较小。
4. 低压保护阈值: 低 / **中** / 高。
1) 当电池类型设定为 Lipo 电池时,电调自动判断锂电节数,低 / 中 / 高情况下每节电池的截止电压分别为: 2.85V/3.15V/3.3V。
例如: 使用 3 节锂电,设定为中截止电压,则低压保护阈值为: $3.15 \times 3 = 9.45V$ 。
2) 当电池类型设定为镍氢电池时,低 / 中 / 高情况下截止电压为开机时输入电压的 0%/50%/65%。0% 意味着不进行低压保护。
例如: 使用 6 节镍氢电池,充满时电压为 $1.44 \times 6 = 8.64V$,当设定为中截止电压时,则截止电压阈值为: $8.64 \times 50\% = 4.3V$ 。
5. 启动模式: **普通** / 柔和 / 超柔和启动,马达转速从静止到最高速度的时间分别为 300ms/1.5s/3s。
普通启动适用于固定翼,柔和启动 / 超柔和启动适用于直升机。柔和启动和超柔和启动的初始转速都比较低,即便瞬时油门摇杆推到最大位置,马达从静止到全速也分别需要 1.5 秒和 3 秒。
(注: 启动过程结束后若关闭油门,3 秒内再次启动,则均自动切换为普通模式,以免在特技飞行时因反应过慢而导致摔机)。
6. 进角: **低** / 中 / 高,分别为 3.75 度 / 15 度 / 26.25 度。
一般情况下,低进角可以适应较多的马达。但是因为马达结构差异很大,请试用各个进角以获得满意的驱动效果。为提高转速,可将进角设为高进角。改变进角后,建议先在地面进行测试,然后再飞行。

产品规格

型号	持续电流	瞬时电流 (10 秒)	BEC 类型	BEC 输出	BEC 驱动微型舵机能力				电池节数		重量	体积 长*宽*高 (mm)
									锂电	镍氢		
6A	6A	8A	线性稳压	5V/0.8A	2 节锂电	3 节锂电	4 节锂电	6 节锂电	2 节	5-6 节	5.5g	32*12*4.5
12A	12A	15A	线性稳压	5V/1A	3 个舵机				2-3 节	5-9 节	9g	38*18*6
12AE	12A	15A	线性稳压	5V/2A	2 个舵机	2 个舵机			2-3 节	5-9 节	10g	38*18*7
15A	15A	20A	线性稳压	5V/2A	5 个舵机	4 个舵机			2-3 节	5-9 节	16.5g	48*22.5*6
20A	20A	25A	线性稳压	5V/2A	5 个舵机	4 个舵机			2-3 节	5-9 节	19g	42*25*8
30A	30A	40A	线性稳压	5V/2A	5 个舵机	4 个舵机			2-3 节	5-9 节	37g	68*25*8
40A	40A	55A	线性稳压	5V/3A	5 个舵机	4 个舵机			2-3 节	5-9 节	39g	68*25*8
40A-UBEC	40A	55A	开关稳压	5V/3A	5 个舵机	5 个舵机	5 个舵机		2-4 节	5-12 节	43g	65*25*12
50A-UBEC	50A	65A	开关稳压	5V/5A	8 个舵机	8 个舵机	6 个舵机	6 个舵机	2-4 节	5-12 节	41g	65*29*10
60A-UBEC	60A	80A	开关稳压	5V/5A	8 个舵机	8 个舵机	6 个舵机	6 个舵机	2-6 节	5-18 节	63g	77*35*14
60A-OPTO	60A	80A	无	无					2-6 节	5-18 节	60g	77*35*14
80A-UBEC	80A	100A	开关稳压	5V/5A	8 个舵机	8 个舵机	6 个舵机	6 个舵机	2-6 节	5-18 节	82g	86*38*12
80A-OPTO	80A	100A	无	无					2-6 节	5-18 节	79g	86*38*12

电调使用说明

首次使用您的无刷电子调速器

特别强调!为了让电调适应您的遥控器油门行程,在首次使用本电调或更换其他遥控器使用时,均应重新设定油门行程。

油门行程设定说明:

1. 开启遥控器,将油门打到最高点。
2. 将电调接上电池,等待 2 秒。
3. “啵 - 啵 -” 油门最高点确认音。
4. 将油门推到最低等待 1 秒。
5. N 声短鸣音表示锂电节数。
6. “啵 -” 油门最低点确认音
7. 系统准备就绪可以起飞。

正常使用开机过程说明:

1. 开启遥控器,将油门打到最低点。
2. 电调接上电池,鸣叫提示音符“♪123”,表示上电正常。
3. 发出 N 声短鸣音,表示锂电池节。
4. 自检 OK,发出长鸣音“啵——”系统准备就绪。
5. 推油门可随时起飞。

电调保护功能说明

1. 启动保护:当推油门启动后,如在两秒内未能正常启动马达,电调将会关闭马达,油门需再次置于最低点后,才可以重新启动。(出现这种情况的原因可能有:电调和马达连接接触不良或有个别输出线断开、螺旋桨被其他物体阻挡、减速齿卡死等)。
2. 温度保护:当电调工作温度超过 110 摄氏度时,电调会降低输出功率进行自我保护,但不会将输出功率全部关闭,最多只降到全功率的 40%,以保证马达仍有动力,避免摔机。温度下降后,电调会逐渐恢复最大动力。
3. 油门信号丢失保护:当检测到油门遥控信号持续丢失 1 秒后,电调开始降低输出功率,如果信号始终无法恢复,则一直降到零输出(降功率过程为 2 秒)。如果在降功率的过程中油门遥控信号重新恢复,则立即恢复油门控制。优点:在油门信号瞬间丢失的情况下(小于 1 秒),电调并不会立即切断动力输出;如果遥控信号确实长时间丢失,则进行保护,但也不是立即关闭输出,而是有一个逐步降低输出功率的过程,给玩家留有一定的时间救机,兼顾安全性和实用性。
4. 过负荷保护:当负载突然变得很大时,电调会切断动力,或自动重启。出现负载急剧增大的原因通常是马达堵转。

故障处理

故障现象	可能原因	解决方法
上电后电机无法启动,无任何声音	电源接头接触不良	重新插好接头或更换接头
上电后电机无法启动,发出“啵 - 啵 -、啵 - 啵 -、啵 - 啵 -”警示音(每两声之间的间隔时间为 1 秒)	电池组电压不正常	检查发射机和接收机的配合是否正常,油门控制通道接线是否插紧
上电后电机无法启动,发出“啵 -、啵 -、啵 -”警示音(每声之间的间隔时间为 2 秒)	接收机油门通道无油门信号输出	检查电池组电压
上电后电机无法启动,发出“啵、啵、啵、啵、啵”急促单音	油门未归零或油门行程设置过小	将油门摇杆置于最低位置;重新设置油门行程
上电后电机无法启动,发出“啵 - 啵 -”提示音,然后发出“56712”特殊提示音	油门通道“正 / 反”向错误	参考遥控器说明书,调整油门通道的“正 / 反”向设置
电机反转	电调输出线和电机线连接的线序错误	将三根输出线中的任意两根对调

遥控器编程设定说明

注意：务必检查遥控器中油门曲线的设置，确保摇杆最低点位置对应的油门输出值为 0，最高点位置对应输出值为 100%。

一、进入编程模式

1. 开启遥控器，将油门打到最高，电调接上电池。
2. 等待 2 秒，马达鸣叫“哔 - 哔 -”提示音。
3. 再等待 5 秒，马达鸣叫“567i2”特殊提示音，表示已经进入编程模式。

二、选择设定项

进入编程设定后，会听到 8 种鸣叫音，按如下顺序循环鸣叫，在鸣叫某个提示音后，3 秒内将油门打到最低，则进入该设定项。

提示音	设定项
“哔” (1 短音)	刹车
“哔 - 哔 -” (2 短音)	电池类型
“哔 - 哔 - 哔 -” (3 短音)	低压保护模式
“哔 - 哔 - 哔 - 哔 -” (4 短音)	低压保护阈值
“哔——” (1 长音)	启动模式
“哔——哔 -” (1 长 1 短)	进角
“哔——哔 - 哔 -” (1 长 2 短)	恢复出厂默认值
“哔——哔——” (2 长音)	退出

注：一长音“哔——”相当于 5 声短音“哔 -”，所以在“选择设定项”中，一长一短的“哔——哔 -”表示第 6 选项，以此

三、选择参数值

马达会循环鸣叫，在鸣叫某个提示音后将油门摇杆打到最高点，则选择该提示音所对应的设定值，接着鸣叫特殊提示音“i5i5”，表示该参数值已被保存。（此时如果不想再设定其它选项，则在 2 秒内将油门摇杆打到最低，即可快速退出编程设定模式；如果还要设定其它选项，则继续等待，退回第二步，再选择其它设定项）。

提示音	“哔 -” 1 声	“哔 - 哔 -” 2 声	“哔 - 哔 - 哔 -” 3 声
设定项			
刹车	无刹车	有刹车	
电池类型	锂电池	镍氢电池	
低压保护方式	逐渐降低功率	立即关闭动力	
低压保护阈值	低	中	高
启动模式	普通模式	柔和启动	超柔和启动
进角	低	中	高

四、退出设定

有如下两种方式退出设定：

1. 在第三步，选择设定值时，鸣叫特殊提示音“i5i5”后，2 秒内将油门摇杆打到最低点，则退出设定。
2. 在第二步，选择设定项时，当电机鸣叫出“哔——哔——”（即第 8 个设定项）两长音后，3 秒内将油门打到最低点，则退出设定。



MADE IN CHINA