

**E-flite**<sup>®</sup>  
ADVANCING ELECTRIC FLIGHT

## F-14 Tomcat Twin 40mm EDF

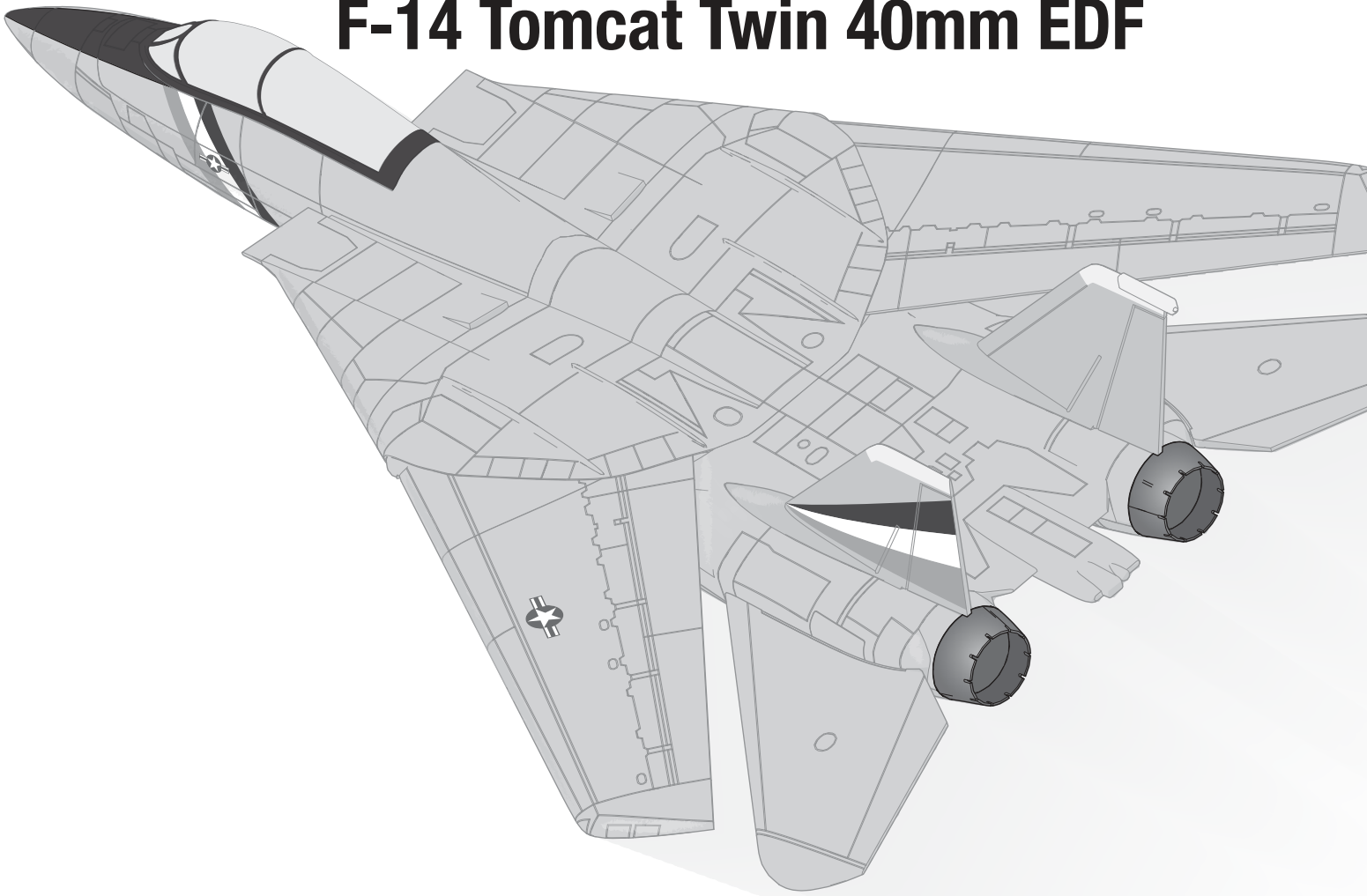

Scan the QR code and select the Manuals and Support quick links from the product page for the most up-to-date manual information.  
Scannen Sie den QR-Code und wählen Sie auf der Produktseite die Quicklinks Handbücher und Unterstützung, um die aktuellsten Informationen zu Handbücher.  
Scannez le code QR et sélectionnez les liens rapides Manuals and Support sur la page du produit pour obtenir les informations les plus récentes sur le manuel.  
Scannerizzare il codice QR e selezionare i Link veloci Manuali e Supporto dalla pagina del prodotto per le informazioni manuali più aggiornate.



**Instruction Manual**  
**Bedienungsanleitung**  
**Manuel d'utilisation**  
**Manuale di Istruzioni**

**HORIZON**<sup>®</sup>  
H O B B Y

## NOTICE

All instructions, warranties and other collateral documents are subject to change at the sole discretion of Horizon Hobby, LLC. For up-to-date product literature, visit [horizonhobby.com](http://horizonhobby.com) or [towerhobbies.com](http://towerhobbies.com) and click on the support or resources tab for this product.

## MEANING OF SPECIAL LANGUAGE

The following terms are used throughout the product literature to indicate various levels of potential harm when operating this product:

**WARNING:** Procedures, which if not properly followed, create the probability of property damage, collateral damage, and serious injury OR create a high probability of superficial injury.

**CAUTION:** Procedures, which if not properly followed, create the probability of physical property damage AND a possibility of serious injury.

**NOTICE:** Procedures, which if not properly followed, create a possibility of physical property damage AND little or no possibility of injury.



**WARNING:** Read the ENTIRE instruction manual to become familiar with the features of the product before operating. Failure to operate the product correctly can result in damage to the product, personal property and cause serious injury.

This is a sophisticated hobby product. It must be operated with caution and common sense and requires some basic mechanical ability. Failure to operate this Product in a safe and responsible manner could result in injury or damage to the product or other property. This product is not intended for use by children without direct adult supervision. Do not use with incompatible components or alter this product in any way outside of the instructions provided by Horizon Hobby, LLC. This manual contains instructions for safety, operation and maintenance. It is essential to read and follow all the instructions and warnings in the manual, prior to assembly, setup or use, in order to operate correctly and avoid damage or serious injury.

**AGE RECOMMENDATION: Not for children under 14 years. This is not a toy.**

## Safety Precautions and Warnings

As the user of this product, you are solely responsible for operating in a manner that does not endanger yourself and others or result in damage to the product or the property of others.

- Always keep a safe distance in all directions around your model to avoid collisions or injury. This model is controlled by a radio signal subject to interference from many sources outside your control. Interference can cause momentary loss of control.
- Always operate your model in open spaces away from full-size vehicles, traffic and people.
- Always carefully follow the directions and warnings for this and any optional support equipment (chargers, rechargeable battery packs, etc.).
- Always keep all chemicals, small parts and anything electrical out of the reach of children.
- Always avoid water exposure to all equipment not specifically designed and protected for this purpose. Moisture causes damage to electronics.
- Never place any portion of the model in your mouth as it could cause serious injury or even death.
- Never operate your model with low transmitter batteries.
- Always keep aircraft in sight and under control.
- Always use fully charged batteries.
- Always keep transmitter powered on while aircraft is powered.
- Always remove batteries before disassembly.
- Always keep moving parts clean.
- Always keep parts dry.
- Always let parts cool after use before touching.
- Always remove batteries after use.
- Always ensure failsafe is properly set before flying.
- Never operate aircraft with damaged wiring.
- Never touch moving parts.



**WARNING AGAINST COUNTERFEIT PRODUCTS:** If you ever need to replace your Spektrum receiver found in a Horizon Hobby product, always purchase from Horizon Hobby, LLC or a Horizon Hobby authorized dealer to ensure authentic high-quality Spektrum product. Horizon Hobby, LLC disclaims all support and warranty with regards, but not limited to, compatibility and performance of counterfeit products or products claiming compatibility with DSM or Spektrum technology.

Quick Start Information			
<b>Transmitter Setup</b>	Set up your transmitter using the transmitter setup chart		
<b>Dual Rates</b>		<b>High Rate</b>	<b>Low Rate</b>
	Aileron	▲ = 20mm ▼ = 20mm	▲ = 13mm ▼ = 13mm
	Elevator	▲ = 15mm ▼ = 15mm	▲ = 10mm ▼ = 10mm
	<b>Flight Timer Setting</b>	3:30 minutes	

## Specifications

	
<b>Motors:</b> 1820 – 6800Kv 6-Pole Brushless outrunner (SPMXAM1600)	<b>Installed</b>
<b>Flight Controller:</b> Spektrum A3240 AS3X/SAFE receiver with dual brushless ESCs (SPMA3240)	<b>Installed</b>
<b>Servos:</b> Tailerons: SPM2040T 2.9g Linear Servo (2) Nose wheel steering: SPMSA2030L 2.3g Linear Servo Wing Sweep: EFL01469 3-Position Linear Actuator	<b>Installed</b>
<b>Recommended Battery:</b> 14.8V 4S 2200 30C Li-Po with EC3 or IC3 (SPMX22004S30)	<b>Required</b>
<b>Recommended Battery Charger:</b> 4-cell Li-Po battery balancing charger	<b>Required</b>
<b>Recommended Transmitter:</b> Full range 6-channel 2.4GHz with Spektrum DSM2 or DSMX® technology and programmable flight modes (included with NX, iX, DX9, DX18, and all DX G2 era and newer computerized Spektrum transmitters)	<b>Required</b>

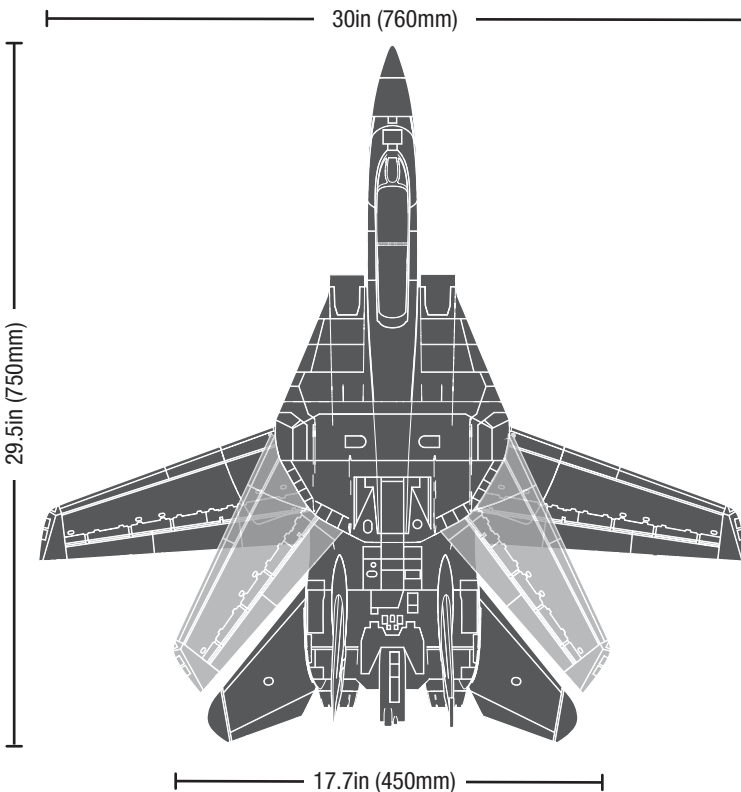

17.6oz / 500g (without battery)  
25.6oz / 725g (with 2200mAh 4S 30C Smart battery)

## Box Contents

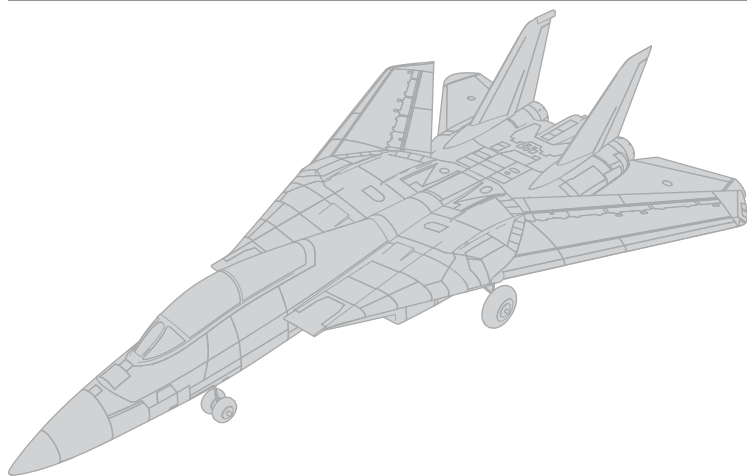

## Table of Contents

Transmitter Setup .....	4
Battery Installation and ESC Arming .....	5
Binding .....	5
Integrated ESC Telemetry .....	5
Flight controller LED .....	5
Failsafe .....	5
SAFE® Select Technology .....	6
Control Surface Direction .....	6
AS3X Control Response Test .....	7
Control Surface Centering .....	7
Dual Rates and Control Throws .....	8
Center of Gravity .....	8
Landing Gear .....	8
Hand Launching .....	9
Trimming .....	9
Flying Tips and Repairs .....	10
SAFE Select Flying Tips .....	10
Post Flight .....	11
Re-Connecting The Swing Wing Linkage .....	11
Replacing a Wing .....	12
Replacing The Taileron .....	12
Power System Installation and Service .....	13
Replacing a Vertical Stabilizer .....	13
Flight Controller Wiring .....	14
Troubleshooting Guide AS3X .....	14
Troubleshooting Guide .....	15
Replacement Parts .....	16
Recommended Items .....	16
AMA National Model Aircraft Safety Code .....	16
Optional Items .....	16
Screw Set: F-14 Tomcat (EFL01468) .....	16
Limited Warranty .....	17
Contact Information .....	17
FCC Information .....	18
IC Information .....	18
Compliance Information for the European Union .....	18

If you own this product, you may be required to register with the FAA. For up-to-date information on how to register with the FAA, please visit <https://registermyuas.faa.gov/>. For additional assistance on regulations and guidance on UAS usage, visit [knowbeforeyoufly.org/](http://knowbeforeyoufly.org/).

## Transmitter Setup

**IMPORTANT:** Transmitter features, functions and settings not listed in the transmitter setup table should remain at the default settings. These transmitter tables show the basic steps needed to complete setup. For more detailed transmitter setup information please refer to your transmitter's manual.

We recommend using the transmitter setup provided. When using the recommended setup, these are the details of the control inputs;

- The GEAR Channel (Ch 5, default switch A) selects SAFE/AS3X mode.
- The Aux 1 Channel (Ch 6, default switch D) controls the wing sweep mechanism. The wing sweep mechanism is not proportional, it uses three pre-determined positions. \*
- Switch C is configured for elevator dual rates.
- Switch F is configured for aileron dual rates.
- Switch H is configured for throttle cut.
- The rudder stick controls nose wheel steering, there are no rudders for flight controls.

\* When the aircraft is powered ON the wing sweep (Aux1) switch has to be in the same position as the wings before the wing sweep will function. The wings will not move until the wing position and switch position align. If they are both in the same position when powered ON they will move together from the start.

### Trim

Our recommended setup uses trims tied to flight modes. With both trims and wing sweep tied to flight modes (Switch D), you can independently trim the aileron and elevator for each wing sweep position. We recommended this configuration for this F-14 aircraft to account for trim changes which may occur in different wing sweep positions.

### Dual Rates

**Attempt your first flights in low rate. For landings, use high rate elevator.**

**NOTICE:** To ensure AS3X technology functions properly, do not lower rate values below 50%.

**NOTICE:** If oscillation occurs at high speed, refer to the Troubleshooting Guide for more information.

### Exponential

After first flights, adjust expo in your transmitter to suit your flying style.

### Telemetry Setup

See the Telemetry Setup table after binding. In order for the ESC and battery information to auto-populate in your transmitter's telemetry menu, you must begin telemetry setup with the aircraft bound and connected.

DX Series Transmitter Setup
1. Power ON your transmitter, click on scroll wheel, roll to <b>System Setup</b> and click the scroll wheel. Choose yes.
2. Go to <b>Model Select</b> and choose <b>&lt;Add New Model&gt;</b> at the bottom of the list. The system asks if you want to create a new model, select <b>Create</b>
3. Set <b>Model Type</b> : Select <b>Airplane Model Type</b> by choosing the airplane. The system asks you to confirm model type, data will be reset. Select <b>YES</b>
4. Set <b>Model Name</b> : Input a name for your model file
5. Set <b>F-Mode Setup</b> (Flight Mode); <b>Switch 1: Switch D</b>
6. Set <b>Trim Setup</b> ; <b>Aileron: 5 F Mode</b> <b>Elevator: 5 F Mode</b>
7. Select <b>&lt;Main Screen&gt;</b> , Click the scroll wheel to enter the <b>Function List</b>
8. Set <b>D/R (Dual Rate) and Expo; Aileron</b> Set <b>Switch: Switch F</b> Set <b>High Rates: 100%, Expo 10% - Low Rates: 70%, Expo 5%</b>
9. Set <b>D/R (Dual Rate) and Expo; Elevator</b> Set <b>Switch: SWITCH C</b> <b>High Rates: 100%, Expo 10% - Low Rates 70%, Expo 5%</b>
10. Set <b>Throttle Cut; Switch: Switch H, Position: -100%</b>

NX Series Transmitter Setup
1. Power ON your transmitter, click on scroll wheel, roll to <b>System Setup</b> and click the scroll wheel. Choose yes.
2. Go to <b>Model Select</b> and choose <b>&lt;Add New Model&gt;</b> near the bottom of the list. Select <b>Airplane Model Type</b> by choosing the airplane, select <b>Create</b>
3. Set <b>Model Name</b> : Input a name for your model file
4. Set <b>F-Mode Setup</b> (Flight Mode); <b>Switch 1: Switch D</b>
5. Set <b>Trim Setup</b> ; <b>Aileron: 5 F Mode</b> <b>Elevator: 5 F Mode</b>
6. Select <b>&lt;Main Screen&gt;</b> , Click the scroll wheel to enter the <b>Function List</b>
7. Set <b>D/R (Dual Rate) and Expo; Aileron</b> Set <b>Switch: Switch F</b> Set <b>High Rates: 100%, Expo 10% - Low Rates: 70%, Expo 5%</b>
8. Set <b>D/R (Dual Rate) and Expo; Elevator</b> Set <b>Switch: SWITCH C</b> <b>High Rates: 100%, Expo 10% - Low Rates 70%, Expo 5%</b>
9. Set <b>Throttle Cut; Switch: Switch H, Position: -100%</b>

iX Series Transmitter Setup
1. Power ON your transmitter and begin once the Spektrum Airware app is open. Select the orange pen icon in the upper left corner of the screen, the system asks for permission to <b>Turn Off RF</b> , select <b>PROCEED</b>
2. Select the three dots in the upper right corner of the screen, select <b>Add a New Model</b>
3. Select Model Option, choose <b>DEFAULT</b> , select <b>Airplane</b> . The system asks if you want to create a new acro model, select <b>Create</b>
4. Select the last model on the list, named <b>Acro</b> . Tap on the word Acro and rename the file to a name of your choice
5. Tap and hold the back arrow icon in the upper left corner of the screen to return to the main screen
6. Go to the <b>Model Setup</b> tab
7. Go to <b>Flight Mode Setup</b> ; The system asks if you want to Turn Off RF, select <b>PROCEED</b> ; set <b>Switch 1: Switch D</b>
8. Set <b>Trim Setup</b> ; <b>Aileron: 5 F Mode</b> <b>Elevator: 5 F Mode</b>
9. Exit <b>Model Setup</b> , Go to the <b>Model Adjust</b> menu
10. Set <b>Dual Rates and Expo</b> ; Select <b>Aileron</b> Set <b>Switch: Switch F</b> Set <b>High Rates: 100%, Expo 10% - Low Rates: 70%, Expo 5%</b>
11. Set <b>Dual Rates and Expo</b> ; Select <b>Elevator</b> Set <b>Switch: SWITCH C</b> <b>High Rates: 100%, Expo 10% - Low Rates 70%, Expo 5%</b>
12. Set <b>Throttle Cut; Switch: Switch H, Position: -100%</b>

Use this QR Code to see videos that will help you get the most out of your F-14 Tomcat setup and flying experience.



## Battery Installation and ESC Arming

### Battery Selection

A 4S 2200mAh LiPo battery is required. The Spektrum 2200mAh 14.8V 4S 30C LiPo battery (SPMX22004S30) is recommended. Refer to the Optional Parts List for other recommended batteries. If using a battery other than those listed, the battery should be within the range of capacity, dimensions and weight of the Spektrum Li-Po battery packs to fit in the fuselage. Be sure the model balances at the recommended CG before flying.

1. Lower the throttle to the lowest settings. Power ON the transmitter, then wait 5 seconds.
2. Remove the battery hatch.
3. Apply the loop side (soft side) of the included hook and loop tape to the bottom of your battery, and the hook side to the battery tray.
4. Install the fully charged battery to the rear of the battery compartment as shown.
5. Connect the battery to the ESC. If you have not completed the bind sequence, do so at this time as outlined in this manual.

**CAUTION:** Always keep hands away from the fan intake. When armed, the motor will turn the rotor in response to any throttle movement.

6. Keep the aircraft immobile and away from wind or the system will not initialize.
  - The motor will emit a tone when the battery is connected, and then 4 even tones indicating the number of cells connected.
  - The motor will emit a series of tones after the flight controller is initialized.
  - An LED on the flight controller will indicate the flight mode after initialized. Reinstall the battery hatch.

### Binding

1. Power the Aircraft ON.
2. The receiver in the flight controller will automatically enter bind mode if it does not connect to a transmitter. Bind mode is indicated by flashing blue and red lights.
3. Put your transmitter into bind mode, the aircraft should connect and establish a bind with your transmitter.
4. The aircraft must be kept upright and stable to initialize.

### Integrated ESC Telemetry

This aircraft includes telemetry between the ESC and receiver, which can provide information including RPM, voltage, motor current, throttle setting (%), and FET (speed controller) temperature.

For more information about compatible transmitters, firmware updates, and how to use the telemetry technology on your transmitter, visit [www.SpektrumRC.com](http://www.SpektrumRC.com).

Telemetry Setup	
DX series, NX series, iX series	1. Begin with the transmitter bound to the receiver.
	2. Power ON the transmitter.
	3. Set switch H (throttle cut) to prevent accidental motor operation.
	4. Power ON the aircraft. A signal bar appears on your transmitter's main screen when the telemetry information is being received.
	5. Go to the FUNCTION LIST
	6. Select TELEMETRY; Smart ESC
	7. Set Total Cells: 4
	8. Set LVC Alarm: 3.4V Set Alarm; Voice/Vibe
	9. Set pole count; 6 pole

**TIP:** Spektrum telemetry receiver voltage alarm default is set at 4.3V. If your alarm is active, change; "Receiver Voltage", Min RX V; 4.0V.

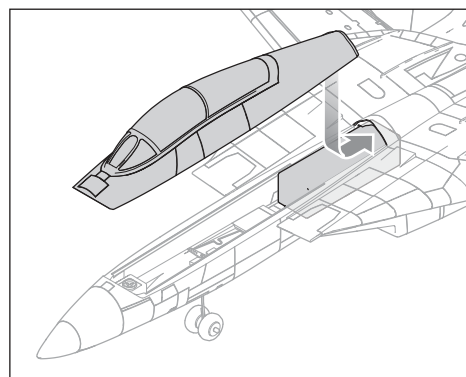
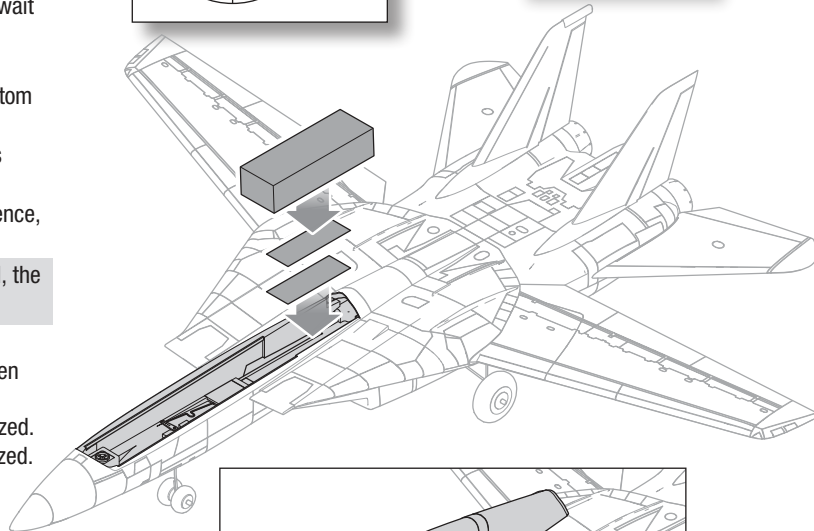
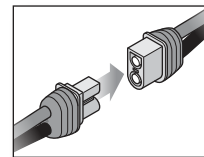
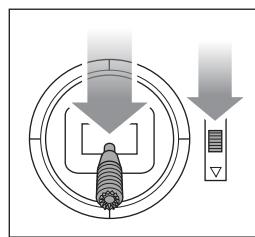

### Flight controller LED

LED Color	Mode
Red and blue flashing	Bind Mode
Solid red and blue	SAFE
Solid red	AS3X

### Failsafe

If the receiver loses transmitter communication, the failsafe will activate. When activated, failsafe moves the throttle channel to its preset failsafe position (low throttle) that was set during binding. All other channels move collectively and actively to place the aircraft in a slow descending turn.

## SAFE® Select Technology

When SAFE Select is activated, bank and pitch limitations keep you from over-controlling the aircraft. Additionally, by releasing the controls in the event you lose orientation, SAFE Select will keep the aircraft level.

To activate SAFE Select, flip the Gear channel switch (Switch A) to position 0. Return the Gear switch to position 1 to turn OFF SAFE Select and fly with just the assistance of AS3X® technology.

If you become disoriented or the aircraft is in a confusing attitude, flip the Gear switch to position 0 and release the sticks. With the aileron and elevator sticks in the neutral position, SAFE Select will automatically keep the airplane in a straight and level attitude.

### Disabling and Enabling SAFE Select

By default, the SAFE Select function of your aircraft is enabled and assigned to the Gear channel switch (channel 5). If you do not wish to have access to SAFE Select while flying, you can choose to disable SAFE Select functionality. AS3X will still be active when SAFE Select is disabled.

SAFE Select cannot be assigned to another channel in this aircraft. Choose to fly with SAFE Select ON or OFF using switch A (by default) when using the suggested transmitter setup.

**IMPORTANT:** Before attempting to disable or enable SAFE Select, ensure the aileron, elevator, rudder, throttle and gear channels are all on high rate with the travel set to 100%. Turn throttle hold OFF if it is programmed in the transmitter.

**CAUTION:** Keep all body parts clear of the rotor, intake and exhaust tube and keep the aircraft securely restrained in case of accidental throttle activation.

1. Power on the transmitter.
2. Power on the aircraft.
3. Hold both transmitter sticks to the inside bottom corners and toggle the Gear switch 5 times (1 toggle = full up and down). The control surfaces of the aircraft will move, indicating SAFE Select has been enabled or disabled.

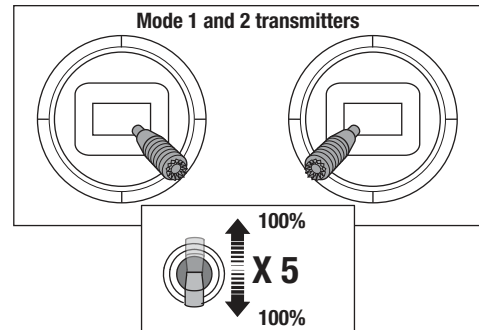

Repeat the process to re-enable or disable SAFE Select.

**Switch A is used for SAFE Select as shown below on the NX8**

**TIP:** If you prefer to use a different switch to control SAFE Select, you can assign it to another switch in your transmitter by changing the switch assigned to gear/channel 5.

**IMPORTANT:** We recommend using high rates when flying with SAFE Select ON

Low rates with SAFE Select ON will reduce the pitch and bank angle limits resulting in less control and wider turns in particular.

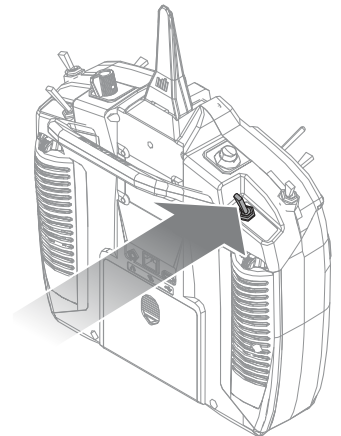

## Control Surface Direction

Switch on the transmitter and connect the battery. Use the transmitter to operate the aileron and elevator controls. Aileron and elevator controls are mixed together on the full flying horizontal stabilizers, creating a taileron configuration. View the aircraft from the rear when checking the control directions.

### Ailerons

1. Move the aileron stick to the left. The right taileron should move down and the left taileron up, which will cause the aircraft to bank left.
2. Move the aileron stick to the right. The right taileron should move up and the left taileron down, which will cause the aircraft to bank right.

### Elevators

3. Pull the elevator stick back. Both tailerons should move up, which will cause the aircraft to pitch up.
4. Push the elevator stick forward. Both tailerons should move down, which will cause the aircraft to pitch down.

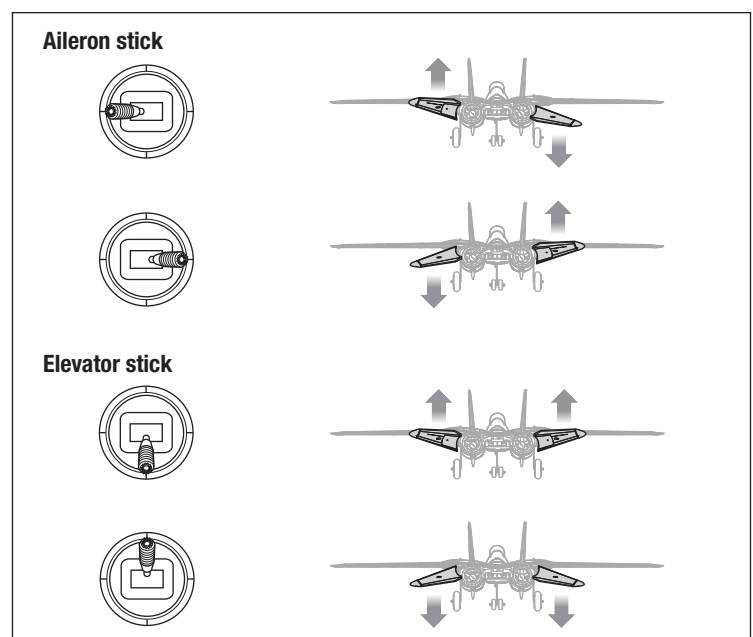

## AS3X Control Response Test

This test ensures that the AS3X control system is functioning properly. Assemble the aircraft and bind your transmitter to the receiver before performing this test.

1. Raise the throttle to any setting above 25%, then lower the throttle to activate AS3X technology.

**CAUTION:** Keep all body parts, hair and loose clothing away from the fan intake, as these items could become entangled.

2. Move the entire aircraft as shown and ensure the control surfaces move in the direction indicated in the graphic. If the control surfaces do not respond as shown, do not fly the aircraft. Refer to the receiver manual for more information.

Once the AS3X system is active, control surfaces may move rapidly. This is normal. AS3X remains active until the battery is disconnected.

	Aircraft movement	AS3X Reaction
Pitch		
Roll		

## Control Surface Centering

After assembly and transmitter setup, confirm the control surfaces are centered. The model must be powered up and bound to the transmitter in AS3X mode, keeping the throttle at zero. When enabled, SAFE mode is active at power up.

AS3X mode is activated when the throttle is raised above 25% for the first time after being powered on. It is normal for the control surfaces to respond to aircraft movement if the aircraft is in AS3X or SAFE modes.

1. Verify the trims and subtrims on your transmitter are zero.
2. Power up the model in AS3X mode and leave the throttle at zero.
3. The tailerons need to be aligned with each other and centered. At neutral the leading edge of the taileron should be 5mm above the mold line in the fuselage as shown, while the aircraft is sitting upright and level. The neutral point shown is the recommended starting point for first flights.
4. If adjustment is required, remove the lower hatch for access to the servo linkages.
5. Adjustments to the tailerons may be made individually by disconnecting the ball link from the control horn and adjusting the length of the pushrod.

**NOTICE:** Be aware of the pushrod bottoming out in the ball linkage. Do not thread the pushrod too far into the ball link or the pushrod will damage the ball link and protrude into the area needed for the control ball.

**IMPORTANT:** When performing the trim setup and checking the trimmed position after the first flight(s), only check the tailerons and adjust the linkages with the wings in the forward (not swept) position.

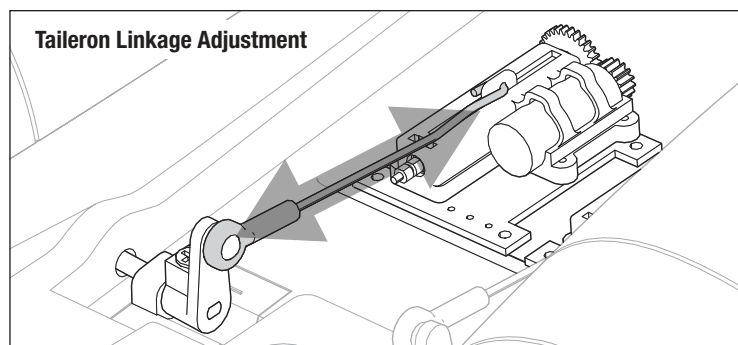
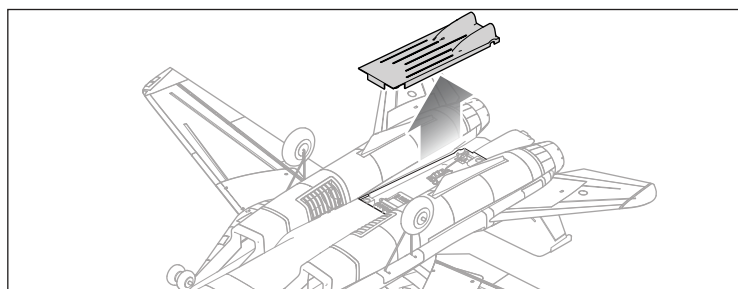
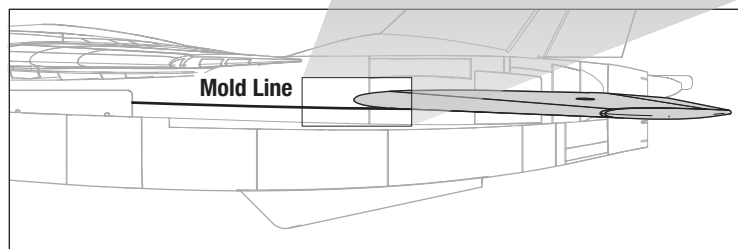
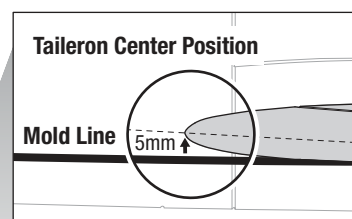

## Dual Rates and Control Throws

Program your transmitter to set the rates and control throws based on your experience level. These values have been tested and are a good starting point to achieve a successful first flight.

After flying, you may choose to adjust the values for the desired control response.

### Taileron Control Throw Measurement

Measure the control throw for the taileron at the leading edge along the fuselage.

**IMPORTANT:** Always measure control throw with the wings in the fully extended position, and in AS3X mode.

	Low Rate	High Rate
<b>Aileron</b>	13mm	20mm
<b>Elevator</b>	10mm	15mm

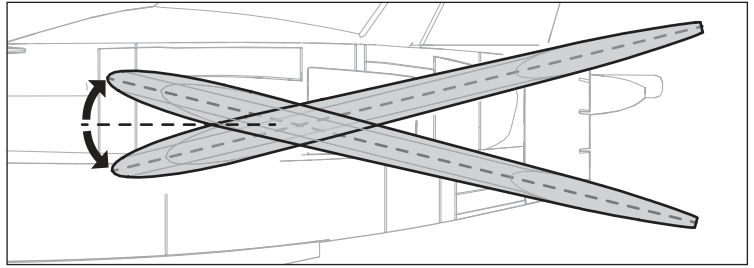

## Center of Gravity

**WARNING:** Install the battery but do not connect it to the ESC while checking the CG. Personal injury may result.

The CG is located at the panel line mark near the wing pivot, and is checked with the wings fully extended, as shown below.

The CG location is adjusted by moving the battery pack forward or backward in the battery compartment.

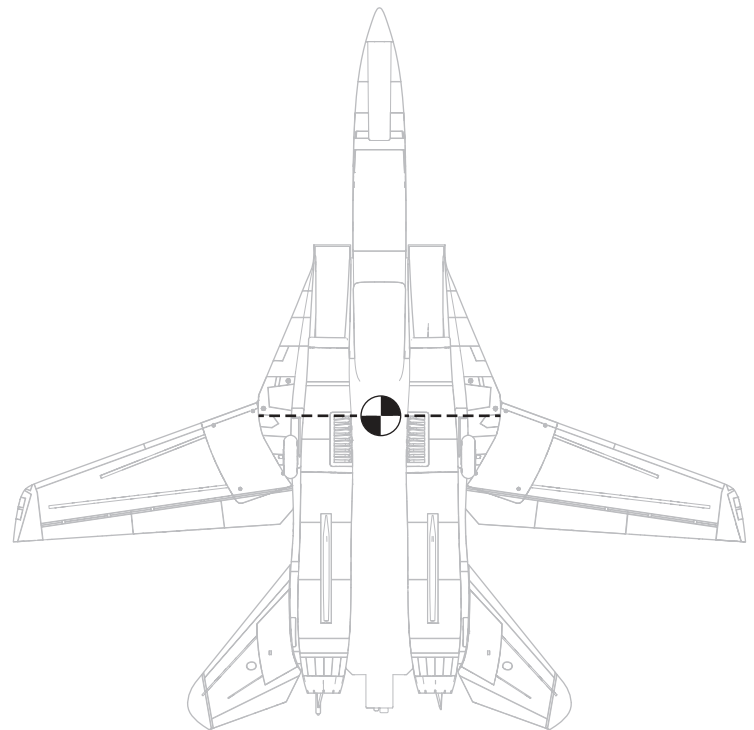
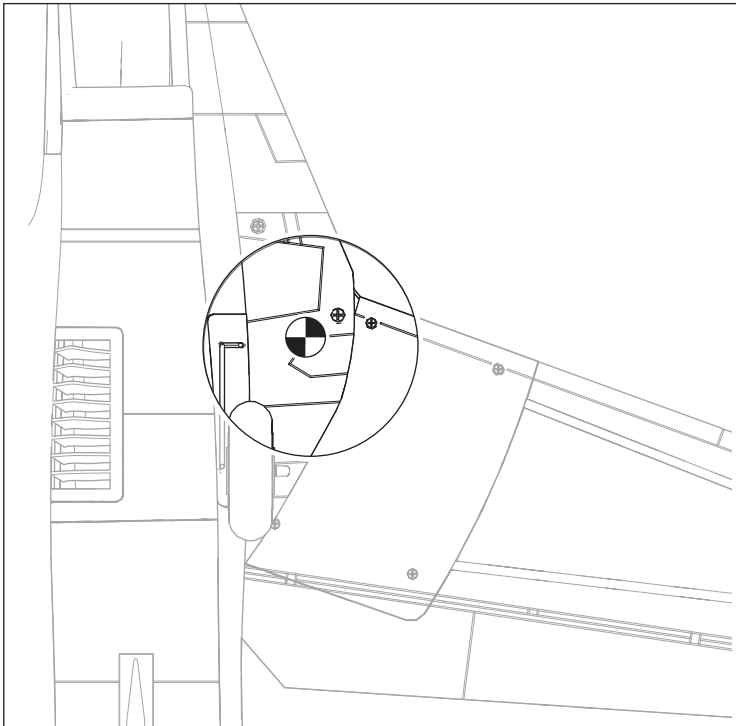

## Landing Gear

The landing gear may be left installed or removed to suit your flying area. We recommend using the landing gear when you can take off and land from a smooth surface. If you are flying from long grass you may choose to remove the landing gear, in which case you will need to hand launch the aircraft and belly land.

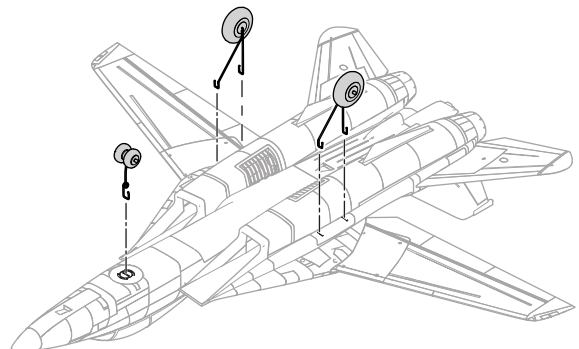

## Hand Launching

### Hand Launching

**NOTICE:** Hand Launching in AS3X mode is not recommended as it may result in a crash. Always hand launch in SAFE mode.

- We recommend flying without landing gear when hand launching.
- Always hand launch in SAFE mode, into the wind with wings forward (not swept), at 100% power, in high rates.

When hand launching in SAFE mode, the control unit will immediately sense the force of the launch and will automatically enable the Hand Launch Assist Mode. In this mode the control unit will add up elevator automatically so the aircraft climbs at a higher angle for a few seconds. It will return to standard SAFE mode shortly after launch.

#### Grip

We recommend holding the aircraft with a wide grip around the nacelles, near the center of gravity, as shown.

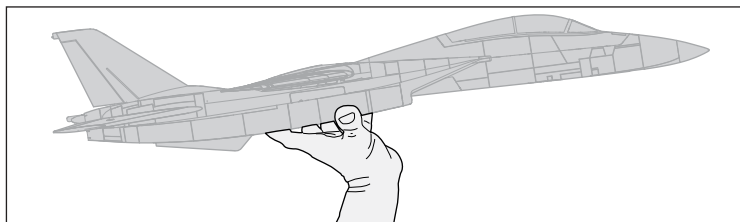
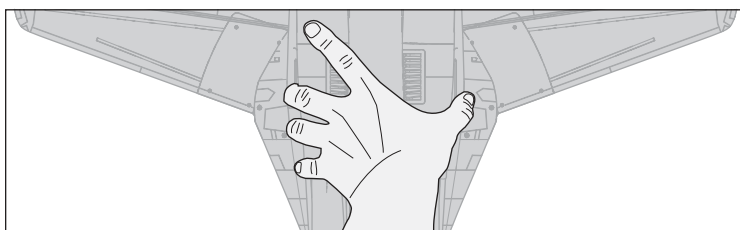
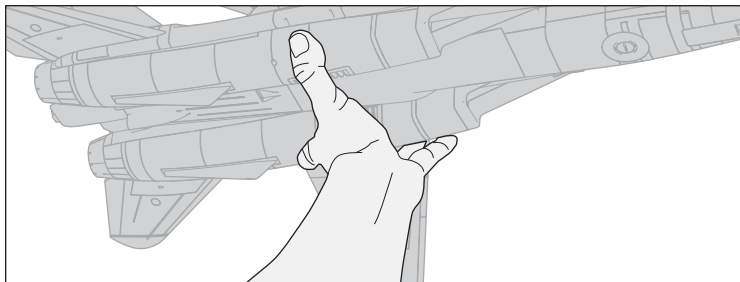

#### Follow Through

Use an overhand throw and launch with wings level and the nose of the model slightly upwards. Follow through with your hand launch by pointing your fingers at the airplane after the throw. Avoid an arching throw which can pull the nose down at release.

## Trimming

The trim process involves trimming for level flight on your transmitter with the wings in the forward position (not swept), and then adjusting the length of the pushrods to reset trim. After adjusting the length of the pushrods, you will need to re-center the trims on your transmitter. The goal is for the model to be as close to mechanically trimmed as possible with the wings in the forward position (not swept). After the initial trimming process, you can trim for mid and fully swept wing positions; each wing position/flight mode will have an independent trim setting in the transmitter when using the recommended transmitter setup.

#### In-Flight Trimming

- Always trim in AS3X mode. NEVER trim this or any model in SAFE mode.
- Fly with the wings in the forward position (not swept) for initial trimming.
- Flight trim will vary with power settings/speed. Fly at 80% power or above with high rate control throws when trimming.
- Flight trim will change when flying without landing gear installed. Adjust flight trims accordingly.

#### Resetting Transmitter Trim After First Flights

After the first flights it is important to reset your transmitter trims to neutral by following these steps:

1. Center the tailerons, measure and note the neutral point you are now using for each taileron after initial trim flights.
2. Reset the aileron and elevator trims to neutral on the transmitter.
3. If adjustment is required, remove the lower hatch for access to the servo linkages.
4. Change the length of the pushrods to set the tailerons to the measured positions from step 1. To change the length of the pushrod, remove the ball link from the control ball and thread the ball link in or out as needed.
5. Test fly again. Adjust the transmitter trim settings in all wing positions/flight modes (the transmitter trim settings will be different for each wing position which is why flight modes are enabled with the suggested transmitter setups). Adjust the pushrod lengths again if needed to keep the transmitter trim settings as close to neutral as possible with the wings in the forward (not swept) position.

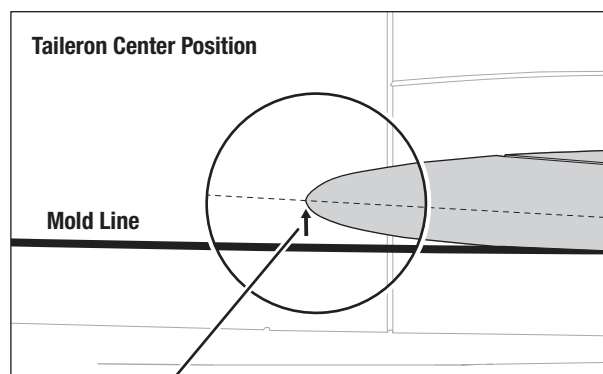

Measure after first flights to determine the trim settings you are using. The model must be powered up and bound to the transmitter in AS3X mode, keeping the throttle at zero, and the measurement should be taken while the aircraft is sitting upright and level.

## Flying Tips and Repairs

Consult local laws and ordinances before choosing a flying location. The E-flite F-14 Tomcat is relatively small and is capable of high speeds, making it capable of covering ground quickly. We recommend flying at designated RC fields. We recommend pilots have some experience flying high-performance EDF aircraft before flying this model. This aircraft is not recommended as your first ducted fan model.

### Getting Started

Before you fly, range check the radio system. Refer to your specific transmitter instruction manual for range test information. When you first connect the battery to the airplane AS3X will not be active. After advancing the throttle the first time, the AS3X system will be active and it is normal to see the control surfaces react to aircraft movement. For your first flights set your transmitter timer or a stopwatch to 3:30. Adjust your timer for longer or shorter flights once you have flown the model.

### Takeoff

Face the aircraft into the wind for takeoff, and set the wings to fully extended. Gradually increase the throttle to full, and steer on the ground with rudder control as necessary to keep the aircraft rolling straight. Be aware the nose wheel will become more sensitive as speed increases. Leave the elevator at neutral and allow the aircraft to accelerate up to speed on the ground, then pull up gently on the elevator to rotate for takeoff. When airborne, climb to a comfortable altitude.

### Flying

For your first flights climb to a moderate altitude and get comfortable with the aircraft while the battery is fresh. Get a feel for the aircraft's low speed performance at a safe altitude (approximately 100 feet or more) before being required to make your first landing attempt. Experiment with high and low speed flight with the wings swept back and with the wings fully extended. Land the aircraft when the timer expires. If at any time the motor power reduces, land the aircraft immediately to recharge the flight battery. See the Low Voltage Cutoff (LVC) section for more details on maximizing battery health and run time.

### Landing

Plan to land the aircraft into the wind when possible. Fly downwind and turn into the wind to begin the approach. Extend the wings, and lower the throttle. Having the wings fully extended will allow the aircraft to fly slower and is recommended for landing. Keep the aircraft pointed into the wind and the wings level during the approach and descent. As the aircraft settles into the final approach you should try to maintain a consistent and slightly nose high attitude. With the angle maintained during the descent, the speed and descent rate is mostly controlled with small throttle changes. Stay in the throttle to maintain speed and control during descent until the aircraft is ready to flare. As the airplane descends into ground effect, fully lower the throttle, pull the nose up more to bleed off airspeed (flare), and the aircraft will settle on its wheels. Because there is no rudder, avoid applying rudder control

## SAFE Select Flying Tips

When flying in SAFE Select mode the aircraft will return to level flight any time the aileron and elevator controls are at neutral. Applying aileron or elevator control will cause the airplane to bank, climb or dive. The amount the stick is moved will determine the attitude the airplane flies. Holding full control will push the aircraft to the pre-determined bank and roll limits, but it will not go past those angles.

When flying with SAFE Select, it is normal to hold the control stick deflected with moderate aileron input when flying through a turn. To fly smoothly with SAFE Select, avoid making frequent control changes and don't attempt to correct for minor deviations. Holding deliberate control inputs will command the aircraft to fly at a specific angle, and the model will make all corrections to maintain that flight attitude.

When flying with SAFE Select, throttle will make the aircraft climb or descend. Full throttle will cause the aircraft to pitch up and climb slightly. Mid throttle will keep the airplane flying level. Low throttle will cause the airplane to descend slightly nose-down.

Return the elevator and aileron controls to neutral before switching from SAFE Select mode to AS3X mode. If you do not neutralize controls when switching into AS3X mode, the control inputs used for SAFE Select mode will be excessive for AS3X mode and the aircraft will react immediately.

until after touchdown; if you are holding rudder input at touchdown the aircraft will transition suddenly from no rudder response in the air to a sensitive nosewheel at high speed and the aircraft could veer off the runway. If landing on grass, it is best to hold full up elevator after touchdown and when taxiing to prevent the nose from digging in. Once on the ground, avoid sharp turns until the plane has slowed enough to prevent scraping the wing tips.

**NOTICE:** If a crash is imminent, reduce the throttle and trim fully. Failure to do so could result in extra damage to the airframe, as well as damage to the ESC and motor.

**NOTICE:** After any impact, always ensure the receiver is secure in the fuselage. If you replace the receiver, install the new receiver in the same orientation as the original receiver or damage may result.

**NOTICE:** Crash damage is not covered under warranty.

**NOTICE:** When you are finished flying, never leave the aircraft in direct sunlight or in a hot, enclosed area such as a car. Doing so can damage the aircraft.

### Low Voltage Cutoff (LVC)

When a Li-Po battery is discharged below 3V per cell, it will not hold a charge. The ESC protects the flight battery from over-discharge using Low Voltage Cutoff (LVC). Before the battery charge decreases too much, LVC removes power supplied to the motor. Power to the motor reduces, showing that some battery power is reserved for flight control and safe landing. Disconnect and remove the Li-Po battery from the aircraft after use to prevent trickle discharge. Charge your Li-Po battery to about half capacity before storage. During storage, make sure the battery charge does not fall below 3V per cell. LVC does not prevent the battery from over-discharge during storage.

**NOTICE:** Repeated flying to LVC will damage the battery.

**TIP:** Monitor your aircraft battery's voltage before and after flying with a Li-Po Cell Voltage Checker (SPMXBC100, sold separately).

### Oscillation

For most flight maneuvers the aircraft should fly smoothly and normal, but it is possible in some flight conditions you may see oscillation (the aircraft rocks back and forth on one axis due to overcontrol). If oscillation occurs, refer to the Troubleshooting Guide for more information.

### Repairs

Thanks to the EPO foam material in this aircraft, repairs to the foam can be made using virtually any adhesive (hot glue, regular CA, epoxy, etc). When parts are not repairable, see the Replacement Parts List for ordering by item number. For a listing of all replacement and optional parts, refer to the list at the end of this manual.

**NOTICE:** Use of CA accelerant on your aircraft can damage paint. DO NOT handle the aircraft until accelerant fully dries.

### Differences between SAFE Select and AS3X modes

This section is generally accurate but does not take into account flight speed, battery charge status, and other limiting factors.

		SAFE Select	AS3X
Control Input	Control stick is neutralized	Aircraft will self level	Aircraft will continue to fly at its present attitude
	Holding a small amount of control	Aircraft will bank or pitch to a moderate angle and maintain the attitude	Aircraft will continue to pitch or roll slowly
	Holding full control	Aircraft will bank or pitch to the predetermined limits and maintain the attitude	Aircraft will continue to roll or pitch rapidly
	Throttle	Full throttle: Climb Neutral: Level flight Low throttle: Descend	Throttle will not affect flight response.

## Post Flight

1. Disconnect the flight battery from the ESC (required for safety and battery life).
2. Power OFF the transmitter.
3. Remove the flight battery from the aircraft.
4. Recharge the flight battery to storage voltage level.

5. Repair or replace all damaged parts.

6. Store the flight battery apart from the aircraft and monitor the battery charge.

7. Make note of the flight conditions and flight plan results, planning for future flights.

## Re-Connecting The Swing Wing Linkage

The wing sweep mechanism is designed to disengage and prevent damage in the event of an impact on the wing. In the event the wing swing mechanism becomes disengaged, the linkage needs to be re-connected to the wing.

To re-connect the wing(s):

1. Remove the bottom fuselage cover from the bottom of the aircraft.
2. Use a magnetized screwdriver to remove the four screws from the bottom of the aircraft that hold the top fuselage cover.
3. Lift at the rear of the top fuselage cover and pull rearward to disengage the clips at the front of the cover, then remove the cover.
4. Power your transmitter and the aircraft ON and move the wing swing mechanism to the wings fully out position.
5. Snap the wing swing linkage back together.
6. Verify the wing swing mechanism is working correctly.
7. Replace the top cover. Insert the two clips at the leading edge of the cover into their respective slots in the fuselage and ensure the hatch is moved forward to fully engage the clips.
8. Reinstall the screws for the top fuselage cover; tighten the front screws first, and then the rear.
9. Reinstall the bottom fuselage cover.
10. Verify the wing swing mechanism is working correctly.

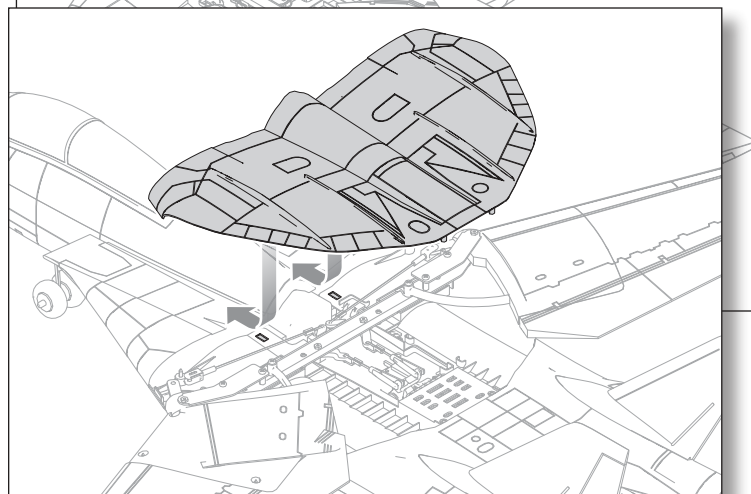
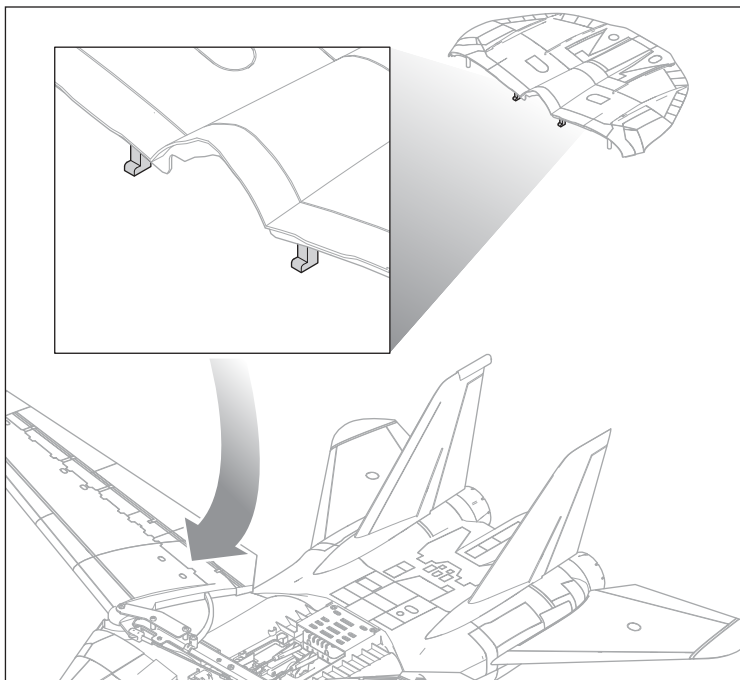
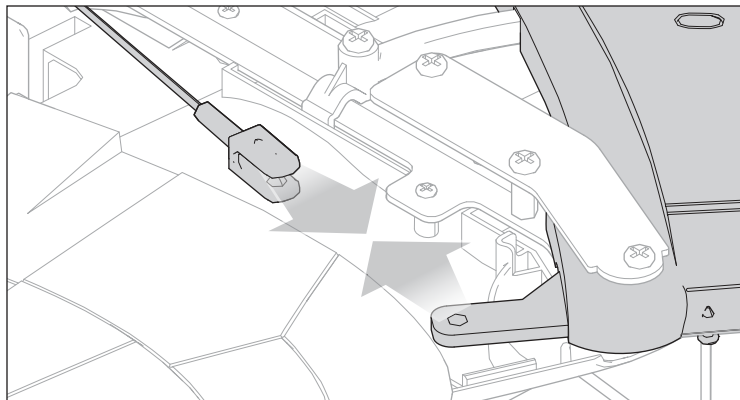
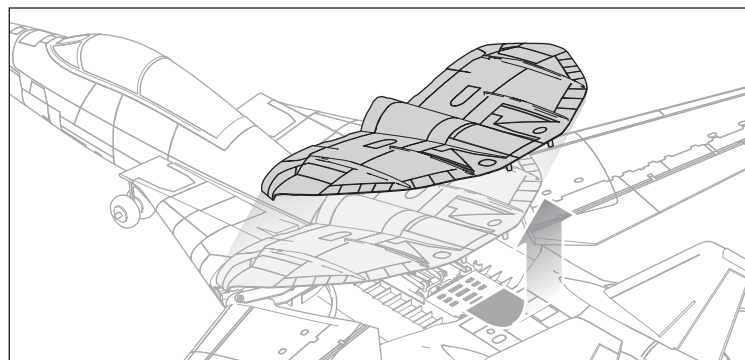
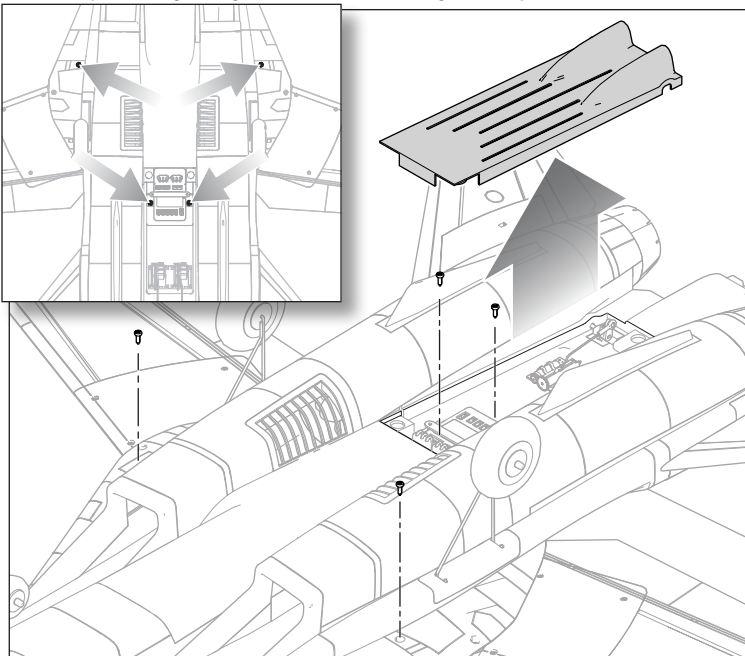

## Replacing a Wing

To replace the wing(s):

1. Remove the bottom fuselage cover from the bottom of the aircraft.
2. Use a magnetized screwdriver to remove the four screws from the bottom of the aircraft that hold the top fuselage cover.
3. Lift at the rear of the top fuselage cover and pull rearward to disengage the clips at the front of the cover, then remove the cover.
4. Power your transmitter and the aircraft ON and move the wing swing mechanism to the wings fully out position.
5. Disengage the wing swing mechanism from the wing
6. Remove the pivot bolt and rotate the wing off the wing swing mechanism.
7. Install the new wing on the wing swing mechanism.
8. Replace the pivot bolt.
9. Snap the wing swing linkage back together.
10. Verify the wing swing mechanism is working correctly.
11. Replace the top cover. Insert the two clips at the leading edge of the cover into their respective slots in the fuselage and ensure the hatch is moved forward to fully engage the clips.
12. Reinstall the screws for the top fuselage cover.
13. Reinstall the bottom fuselage cover.
14. Verify the wing swing mechanism is working correctly.

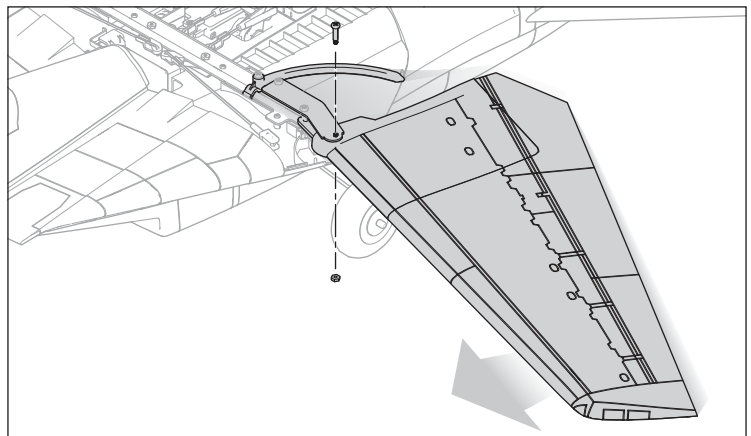
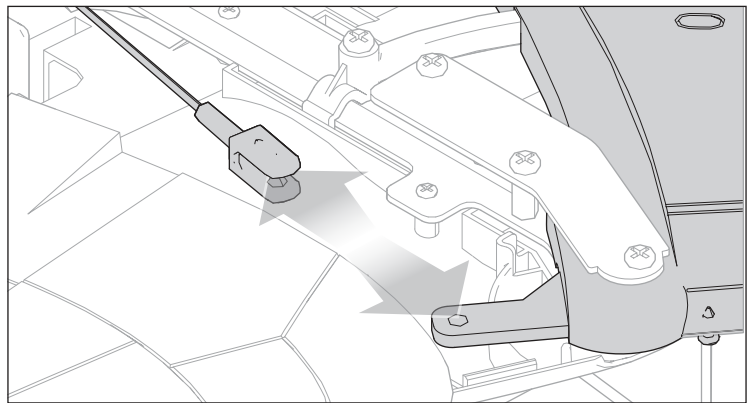

## Replacing The Taileron

In the event a taileron needs to be replaced or the taileron control mechanism needs maintenance, the servo linkages need to be reset for the correct center position.

To re-center the full flying taileron(s):

1. Remove the bottom fuselage cover on the bottom of the aircraft.
2. Loosen the set screw in the control horn to enable removal of the taileron. Repair or replace as necessary.
3. Re-install the taileron and ensure the setscrew is tightened onto the flat spot on the taileron pivot shaft.
4. Turn ON the transmitter and connect power to the aircraft with the throttle cut activated and in AS3X mode.
5. Verify the taileron servos are working correctly and the trim is centered. Disconnect the power from the aircraft (linear actuator servos can be set up without power once centered, unlike rotary servos).
6. Install the pushrod and check the center position.
7. If the taileron leading edge is not centered with the fuselage seam as described in the Control Surface Centering section, adjust the length of the pushrod.
8. Do not use electronic trim to make this adjustment, the taileron needs to be mechanically centered with the electronic trim at neutral.

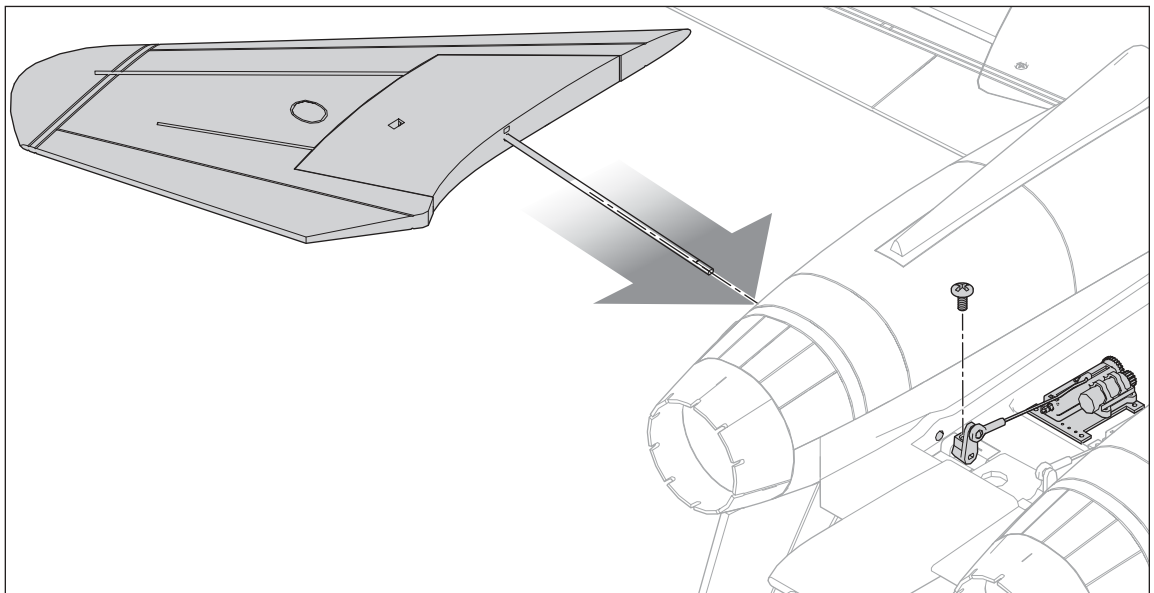

## Power System Installation and Service

**CAUTION:** Always disconnect the flight battery before performing motor service.

The recommended power system components are given in the Specifications table at the beginning of this manual.

1. Use a fresh hobby knife to cut along the glue seam for the lower rear fan ducting to reveal the ducted fan unit.
2. The fan unit is glued in place, remove it by gently twisting the fan enclosure.
3. Repair or replace the fan parts as necessary.
4. Reinstall the fan with a small dab of medium or thick CA glue; the fan enclosure is captured in the foam which provides most of the mounting strength.
5. Install the fan enclosure with small dabs of medium or thick CA glue along the fore/aft seam and along the leading edge of the part.

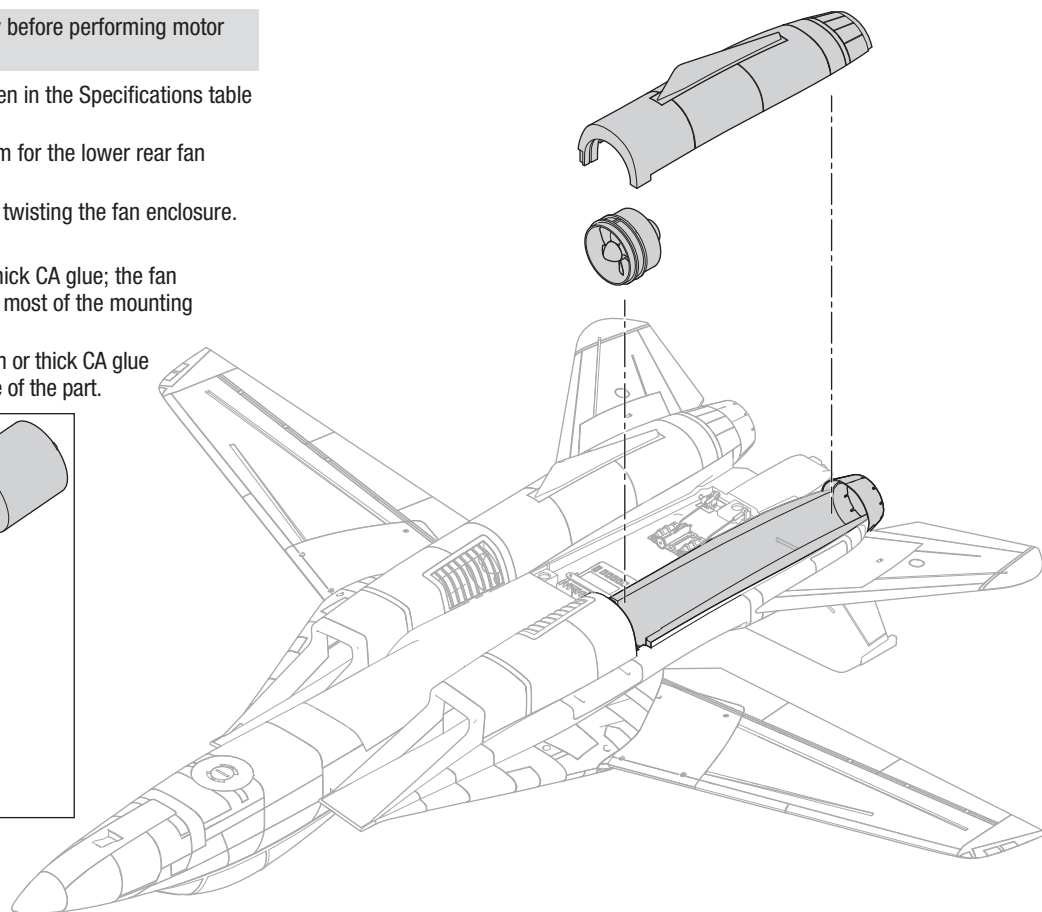
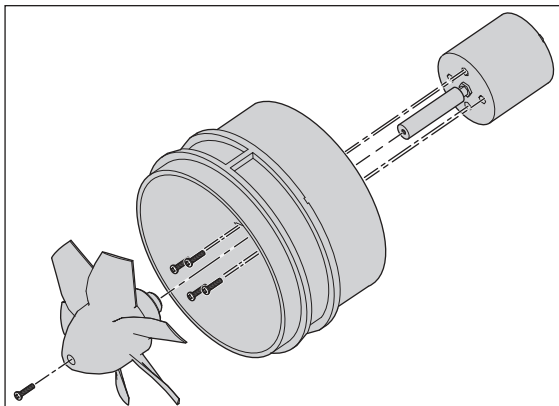

## Replacing a Vertical Stabilizer

In the event the vertical stabilizer(s) needs maintenance, the stabilizer will need to be removed so the replacement can be installed.

To replace the vertical stabilizer(s):

1. Use a fresh hobby knife to cut out any vertical stabilizer material from the mounting location.
2. Secure the new vertical stabilizer in place with thick CA.
3. Be prepared to wipe off any excess glue with a paper towel when you press the stabilizer into place.

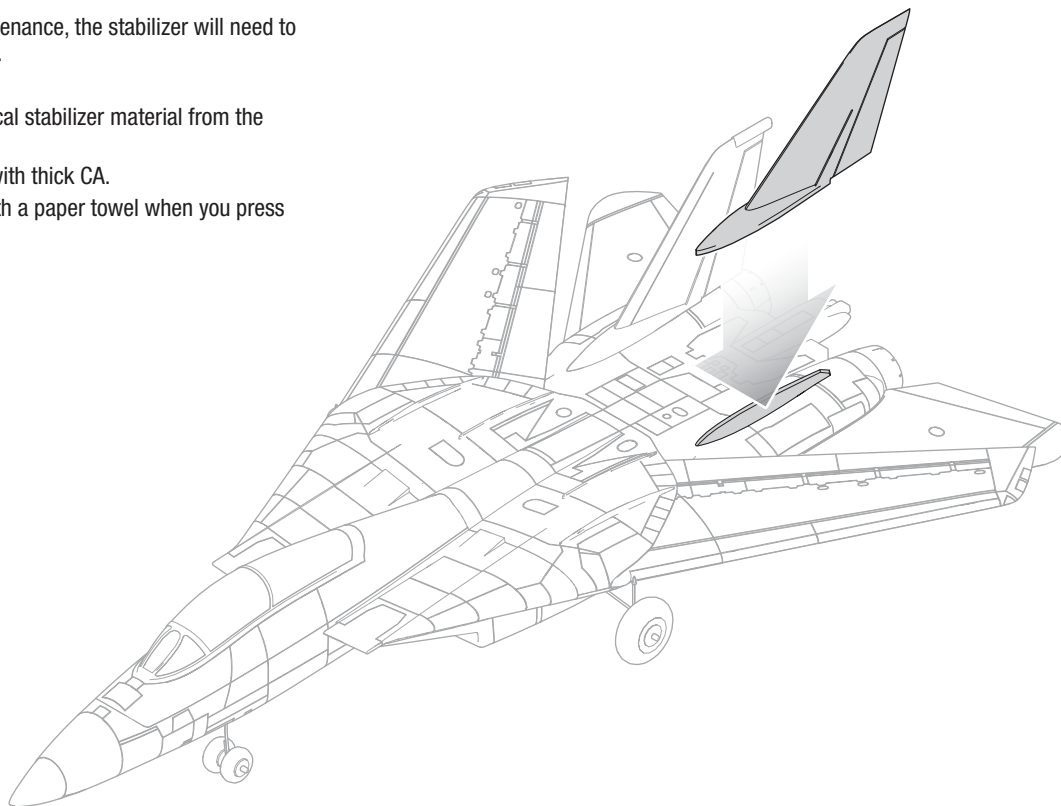

## Flight Controller Wiring

All the functions of this aircraft are handled in the flight controller. If you need to remove the flight controller it needs to be reinstalled in the same orientation as originally mounted. The servo connectors should be at the rear of the receiver, facing down.

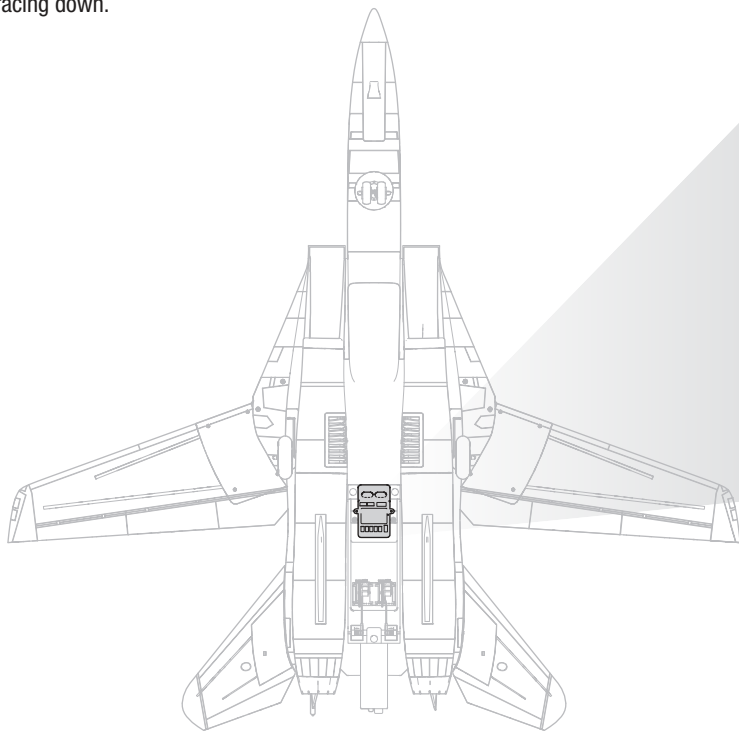

Reference the following diagram for servo and motor connections.

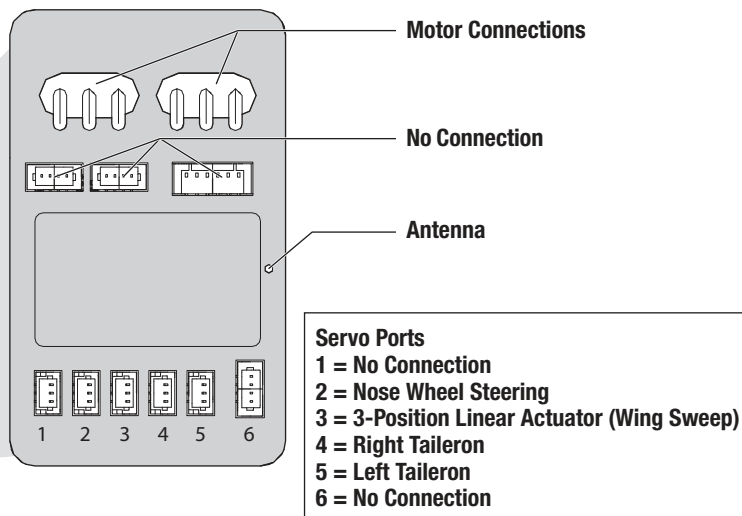

## Troubleshooting Guide AS3X

Problem	Possible Cause	Solution
Oscillation	Damaged rotor or nose cone	Replace rotor or nose cone
	Imbalanced rotor	Balance the rotor
	Motor vibration	Replace parts or correctly align fan unit or other parts and tighten fasteners as needed
	Loose receiver	Align and secure receiver in fuselage
	Loose aircraft controls	Tighten or otherwise secure parts (servo, arm, linkage, horn and control surface)
	Worn parts	Replace worn parts (especially rotor, nose cone, or servo)
	Irregular servo movement	Replace servo
Inconsistent flight performance	Trim is not at neutral	If you adjust trim more than 8 clicks, adjust the ball link to remove trim
	Sub-Trim is not at neutral	No Sub-Trim is allowed. Adjust the servo linkage
	Aircraft was not kept immobile for 5 seconds after battery connection	With the throttle stick in lowest position. Disconnect battery, then reconnect battery and keep the aircraft still for 5 seconds
Incorrect response to the AS3X Control Direction Test	Receiver installed incorrectly	DO NOT fly. Correct the installation, then recheck the AS3X control direction test before flying

## Troubleshooting Guide

Problem	Possible Cause	Solution
Aircraft will not respond to throttle but responds to other controls	Throttle not at idle and/or throttle trim too high	Reset controls with throttle stick and throttle trim at lowest setting
	Throttle servo travel is lower than 100%	Make sure throttle servo travel is 100% or greater
	Throttle channel is reversed	Reverse throttle channel on transmitter
	Motor disconnected from ESC	Make sure motor is connected to the ESC
Excessive fan noise or excessive vibration	Damaged fan, nose cone, collet or motor	Replace damaged parts
	Fan is out of balance	Balance or replace fan
	Fan screw is loose	Tighten the fan screw
Reduced flight time or aircraft underpowered	Flight battery charge is low	Completely recharge flight battery
	Flight battery damaged	Replace flight battery and follow flight battery instructions
	Flight conditions may be too cold	Make sure battery is not cold before use (Do not apply heat to the battery)
	Battery capacity too low for flight conditions	Replace battery or use a larger capacity battery
Aircraft will not bind (during binding) to transmitter	Transmitter too near aircraft during binding process	Move powered transmitter a few feet from aircraft, disconnect and reconnect flight battery to aircraft
	Aircraft or transmitter is too close to large metal object, wireless source or another transmitter	Move aircraft and transmitter to another location and attempt binding again
	The bind plug is not installed correctly in the bind port	Install bind plug in bind port and bind the aircraft to the transmitter
	Flight battery/transmitter battery charge is too low	Replace/recharge batteries
	Bind switch or button not held long enough during bind process	Power off transmitter and repeat bind process. Hold transmitter bind button or switch until receiver is bound
Aircraft will not connect (after binding) to transmitter	Transmitter too near aircraft during connecting process	Move powered transmitter a few feet from aircraft, disconnect and reconnect flight battery to aircraft
	Aircraft or transmitter is too close to large metal object, wireless source or another transmitter	Move aircraft and transmitter to another location and attempt connecting again
	Bind plug left installed in bind port	Rebind transmitter to the aircraft and remove the bind plug before cycling power
	Aircraft bound to different model memory (ModelMatch™ radios only)	Select correct model memory on transmitter
	Flight battery/Transmitter battery charge is too low	Replace/recharge batteries
	Transmitter may have been bound to a different aircraft using different DSM protocol	Bind aircraft to transmitter
Control surface does not move	Control surface, control horn, linkage or servo damage	Replace or repair damaged parts and adjust controls
	Wire damaged or connections loose	Do a check of wires and connections, connect or replace as needed
	Transmitter is not bound correctly or the incorrect airplanes was selected	Re-bind or select correct airplanes in transmitter
	Flight battery charge is low	Fully recharge flight battery
	BEC (Battery Elimination Circuit) of the ESC is damaged	Replace ESC
Controls reversed	Transmitter settings are reversed	Perform the Control Direction Test and adjust the controls on transmitter appropriately
Motor power pulses then motor loses power	ESC uses default soft Low Voltage Cutoff (LVC)	Recharge flight battery or replace battery that is no longer performing
	Weather conditions might be too cold	Postpone flight until weather is warmer
	Battery is old, worn out, or damaged	Replace battery
	Battery C rating might be too low	Use recommended battery

## Replacement Parts

Part #	Description
EFL01451	Fuselage: F-14 Tomcat 40mm Twin
EFL01452	Wing Set: F-14 Tomcat 40mm Twin
EFL01453	Taileron Set: F-14 40mm Twin
EFL01454	Fin Set: F-14 40mm Twin
EFL01455	Landing Gear Set: F-14 40mm
EFL01456	Canopy: F-14 Tomcat 40mm Twin
EFL01457	Pushrod Set w/Clevis: F-14 40mm
EFL01458	Nacelle Set: F-14 40mm Twin
EFL01459	Rotor Fan: F-14 Tomcat 40mm Twin
EFL01460	Fan Unit w/Rotor: F-14 40mm
EFL01461	Top Fuselage Cover: F-14 40mm
EFL01462	Bottom Fuselage Cover: F-14 40mm
EFL01463	Control Arms: F-14 40mm Twin
EFL01464	Swing Wing Guides: F-14 40mm
EFL01465	Center Wing Spar: F-14 40mm
EFL01466	Wing Bolt Bushing Set: F-14 40mm
EFL01467	Decal Set: F-14 Tomcat 40mm
EFL01468	Screw Set: F-14 Tomcat 40mm
EFL01469	3-Position Linear Actuator
EFL01470	Exhaust Tail Cones
SPMA3240	Flight Controller
SPMSA2030L	2.3g Linear Long Throw Servo
SPMSH2040T	2.9g Linear Servo
SPMXAM1600	Brushless Motor; 1820 – 6800Kv 6-Pole

## Recommended Items

Part #	Description
SPMX22004S30	14.8V 2200mAh 4S 30C Smart LiPo, IC3
SPMXC1080	Smart S1100 AC Charger
SPMR6655	DX6e 6-Channel Transmitter

## AMA National Model Aircraft Safety Code

Effective January 1, 2018

A model aircraft is a non-human-carrying device capable of sustained flight within visual line of sight of the pilot or spotter(s). It may not exceed limitations of this code and is intended exclusively for sport, recreation, education and/or competition. All model flights must be conducted in accordance with this safety code and related AMA guidelines, any additional rules specific to the flying site, as well as all applicable laws and regulations.

As an AMA member I agree:

- I will not fly a model aircraft in a careless or reckless manner.
- I will not interfere with and will yield the right of way to all human-carrying aircraft using AMA's See and Avoid Guidance and a spotter when appropriate.
- I will not operate any model aircraft while I am under the influence of alcohol or any drug that could adversely affect my ability to safely control the model.
- I will avoid flying directly over unprotected people, moving vehicles, and occupied structures.
- I will fly Free Flight (FF) and Control Line (CL) models in compliance with AMA's safety programming.
- I will maintain visual contact of an RC model aircraft without enhancement other than corrective lenses prescribed to me. When using an advanced flight system,

## Optional Items

Part #	Description
SPMX224S30	14.8V 2200mAh 4S 30C Smart LiPo G2: IC3
EFLA250	Park Flyer Tool Assortment, 5 pc
SPMXBC100	Smart Battery Checker and Servo Driver
DYN1405	Li-Po Charge Protection Bag, Large
SPMXC1010	Smart S2100 AC Charger, 2X100W
SPMXC1000	Smart S1200 DC Charger 200W
SPMXC10202	Smart 380W Power Supply
SPMR6775	NX6 Transmitter Only
SPMR8200	NX8 Transmitter Only

## Screw Set: F-14 Tomcat (EFL01468)

Qty	Description	Location
9	1X4mm self-tapping screw	1 - Nose Wheel steering arm 8 - Taileron servos
2	1.2X5mm self-tapping screw	Nose Gear Shaft
16	1.6X5mm self-tapping screw	8 - Main wing up/lower plate to wing 8 - Aluminum Wing spar to fuselage
4	1.6X2.0mm Ball link screw	Bell crank ball links
2	2X4.5mm self-tapping screw	Taileron rod collars
4	2.0X6mm self-tapping screw	Fuselage cover
2	2.5X7.9mm screw	Bell crank mounting bolts
6	M2X11mm screw	4 - Upper and lower spar mounting 2 - Main wing guides
3	2.5X8mm self-tapping screw	Actuator mount
8	M2X4mm screw	Motor to fan shroud
8	M2 Nylon insert lock nut	For M2X11mm Aluminum spar bracing
2	1.4X6mm self-tapping screw	ESC Mount
2	M2X8mm screw	Rotor screw
2	M2x12mm Bolts	Main Wing Pivot Bolts
2	M2x4mm Stainless Steel Nuts	Main Wing Pivot Nuts

such as an autopilot, or flying First-Person View (FPV), I will comply with AMA's Advanced Flight System programming.

- I will only fly models weighing more than 55 pounds, including fuel, if certified through AMA's Large Model Airplane Program.
- I will only fly a turbine-powered model aircraft in compliance with AMA's Gas Turbine Program.
- I will not fly a powered model outdoors closer than 25 feet to any individual, except for myself or my helper(s) located at the flight line, unless I am taking off and landing, or as otherwise provided in AMA's Competition Regulation.
- I will use an established safety line to separate all model aircraft operations from spectators and bystanders.

## Limited Warranty

### What this Warranty Covers

Horizon Hobby, LLC, (Horizon) warrants to the original purchaser that the product purchased (the "Product") will be free from defects in materials and workmanship at the date of purchase.

### What is Not Covered

This warranty is not transferable and does not cover (i) cosmetic damage, (ii) damage due to acts of God, accident, misuse, abuse, negligence, commercial use, or due to improper use, installation, operation or maintenance, (iii) modification of or to any part of the Product, (iv) attempted service by anyone other than a Horizon Hobby authorized service center, (v) Product not purchased from an authorized Horizon dealer, (vi) Product not compliant with applicable technical regulations, or (vii) use that violates any applicable laws, rules, or regulations.

OTHER THAN THE EXPRESS WARRANTY ABOVE, HORIZON MAKES NO OTHER WARRANTY OR REPRESENTATION, AND HEREBY DISCLAIMS ANY AND ALL IMPLIED WARRANTIES, INCLUDING, WITHOUT LIMITATION, THE IMPLIED WARRANTIES OF NON-INFRINGEMENT, MERCHANTABILITY AND FITNESS FOR A PARTICULAR PURPOSE. THE PURCHASER ACKNOWLEDGES THAT THEY ALONE HAVE DETERMINED THAT THE PRODUCT WILL SUITABLY MEET THE REQUIREMENTS OF THE PURCHASER'S INTENDED USE.

### Purchaser's Remedy

Horizon's sole obligation and purchaser's sole and exclusive remedy shall be that Horizon will, at its option, either (i) service, or (ii) replace, any Product determined by Horizon to be defective. Horizon reserves the right to inspect any and all Product(s) involved in a warranty claim. Service or replacement decisions are at the sole discretion of Horizon. Proof of purchase is required for all warranty claims. SERVICE OR REPLACEMENT AS PROVIDED UNDER THIS WARRANTY IS THE PURCHASER'S SOLE AND EXCLUSIVE REMEDY.

### Limitation of Liability

HORIZON SHALL NOT BE LIABLE FOR SPECIAL, INDIRECT, INCIDENTAL OR CONSEQUENTIAL DAMAGES, LOSS OF PROFITS OR PRODUCTION OR COMMERCIAL LOSS IN ANY WAY, REGARDLESS OF WHETHER SUCH CLAIM IS BASED IN CONTRACT, WARRANTY, TORT, NEGLIGENCE, STRICT LIABILITY OR ANY OTHER THEORY OF LIABILITY, EVEN IF HORIZON HAS BEEN ADVISED OF THE POSSIBILITY OF SUCH DAMAGES. Further, in no event shall the liability of Horizon exceed the individual price of the Product on which liability is asserted. As Horizon has no control over use, setup, final assembly, modification or misuse, no liability shall be assumed nor accepted for any resulting damage or injury. By the act of use, setup or assembly, the user accepts all resulting liability. If you as the purchaser or user are not prepared to accept the liability associated with the use of the Product, purchaser is advised to return the Product immediately in new and unused condition to the place of purchase.

### Law

These terms are governed by Illinois law (without regard to conflict of law principals). This warranty gives you specific legal rights, and you may also have other rights which vary from state to state. Horizon reserves the right to change or modify this warranty at any time without notice.

### WARRANTY SERVICES

#### Questions, Assistance, and Services

Your local hobby store and/or place of purchase cannot provide warranty support or service. Once assembly, setup or use of the Product has been started, you must contact your local distributor or Horizon directly. This will enable Horizon to better answer your questions and service you in the event that you may need any assistance. For questions or assistance, please visit our website at [www.horizonhobby.com](http://www.horizonhobby.com), submit a Product Support Inquiry, or call the toll free telephone number referenced in the Warranty and Service Contact Information section to speak with a Product Support representative.

#### Inspection or Services

If this Product needs to be inspected or serviced and is compliant in the country you live and use the Product in, please use the Horizon Online Service Request submission process found on our website or call Horizon to obtain a Return Merchandise Authorization (RMA) number. Pack the Product securely using a shipping carton. Please note that original boxes may be included, but are not designed to withstand the rigors of shipping without additional protection. Ship via a carrier that provides tracking and insurance for lost or damaged parcels, as Horizon is not responsible for merchandise until it arrives and is accepted at our facility. An Online Service Request is available at [http://www.horizonhobby.com/content/service-center\\_render-service-center](http://www.horizonhobby.com/content/service-center_render-service-center). If you do not have internet access, please contact Horizon Product Support to obtain a RMA number along with instructions for submitting your product for service. When calling Horizon, you will be asked to provide your complete name, street address, email address and phone number where you can be reached during business hours. When sending product into Horizon, please include your RMA number, a list of the included items, and a brief summary of the problem. A copy of your original sales receipt must be included for warranty consideration. Be sure your name, address, and RMA number are clearly written on the outside of the shipping carton.

**NOTICE:** Do not ship LiPo batteries to Horizon. If you have any issue with a LiPo battery, please contact the appropriate Horizon Product Support office.

#### Warranty Requirements

For Warranty consideration, you must include your original sales receipt verifying the proof-of-purchase date. Provided warranty conditions have been met, your Product will be serviced or replaced free of charge. Service or replacement decisions are at the sole discretion of Horizon.

#### Non-Warranty Service

Should your service not be covered by warranty, service will be completed and payment will be required without notification or estimate of the expense unless the expense exceeds 50% of the retail purchase cost. By submitting the item for service you are agreeing to payment of the service without notification. Service estimates are available upon request. You must include this request with your item submitted for service. Non-warranty service estimates will be billed a minimum of ½ hour of labor. In addition you will be billed for return freight. Horizon accepts money orders and cashier's checks, as well as Visa, MasterCard, American Express, and Discover cards. By submitting any item to Horizon for service, you are agreeing to Horizon's Terms and Conditions found on our website [http://www.horizonhobby.com/content/service-center\\_render-service-center](http://www.horizonhobby.com/content/service-center_render-service-center).

**ATTENTION:** Horizon service is limited to Product compliant in the country of use and ownership. If received, a non-compliant Product will not be serviced. Further, the sender will be responsible for arranging return shipment of the un-serviced Product, through a carrier of the sender's choice and at the sender's expense. Horizon will hold non-compliant Product for a period of 60 days from notification, after which it will be discarded.

10/15

## Contact Information

Country of Purchase	Horizon Hobby	Contact Information	Address
United States of America	Horizon Service Center (Repairs and Repair Requests)	<a href="http://servicecenter.horizonhobby.com/RequestForm/">servicecenter.horizonhobby.com/RequestForm/</a>	2904 Research Rd Champaign, Illinois, 61822 USA
	Horizon Product Support (Product Technical Assistance)	<a href="mailto:productsupport@horizonhobby.com">productsupport@horizonhobby.com</a> 877-504-0233	
	Sales	<a href="mailto:websales@horizonhobby.com">websales@horizonhobby.com</a> 800-338-4639	
European Union	Horizon Technischer Service	<a href="mailto:service@horizonhobby.de">service@horizonhobby.de</a>	Hanskampring 9 D 22885 Barsbüttel, Germany
	Sales: Horizon Hobby GmbH	+49 (0) 4121 2655 100	

## FCC Information

### Contains FCC ID: BRWWAC01T

This equipment complies with FCC and IC radiation exposure limits set forth for an uncontrolled environment. This equipment should be installed and operated with minimum distance 20cm between the radiator and/or antenna and your body (excluding fingers, hands, wrists, ankles and feet). This transmitter must not be co-located or operating in conjunction with any other antenna or transmitter.

### Supplier's Declaration of Conformity

#### F-14 Tomcat Twin 40mm EDF (EFL01450)

 This device complies with part 15 of the FCC Rules. Operation is subject to the following two conditions: (1) This device may not cause harmful interference, and (2) this device must accept any interference received, including interference that may cause undesired operation.



**CAUTION:** Changes or modifications not expressly approved by the party responsible for compliance could void the user's authority to operate the equipment.

**NOTE:** This equipment has been tested and found to comply with the limits for a Class B digital device, pursuant to part 15 of the FCC Rules. These limits are designed to provide reasonable protection against harmful interference in a residential installation. This equipment generates, uses and can radiate radio frequency energy and, if not installed and used in accordance with the instructions, may cause harmful interference to radio communications. However, there is no guarantee that interference will not occur in a particular installation. If this equipment does cause harmful interference to radio or television reception, which can be determined by turning the equipment off and on, the user is encouraged to try to correct the interference by one or more of the following measures:

- Reorient or relocate the receiving antenna.
- Increase the separation between the equipment and receiver.
- Connect the equipment into an outlet on a circuit different from that to which the receiver is connected.
- Consult the dealer or an experienced radio/TV technician for help.

Horizon Hobby, LLC  
2904 Research Rd.,  
Champaign, IL 61822  
Email: [compliance@horizonhobby.com](mailto:compliance@horizonhobby.com)  
Web: [HorizonHobby.com](http://HorizonHobby.com)

## IC Information

### Contains IC: 6157A-WAC01T

#### CAN ICES-3 (B)/NMB-3(B)

This device contains license-exempt transmitter(s)/receiver(s) that comply with Innovation, Science, and Economic Development Canada's license-exempt RSS(s). Operation is subject to the following 2 conditions:

1. This device may not cause interference.
2. This device must accept any interference, including interference that may cause undesired operation of the device.

## Compliance Information for the European Union

### EU Compliance Statement: F-14 Tomcat Twin 40mm EDF (EFL01450)

Hereby, Horizon Hobby, LLC declares that the device is in compliance with the following: EU Radio Equipment Directive 2014/53/EU; RoHS 2 Directive 2011/65/EU; RoHS 3 Directive - Amending 2011/65/EU Annex II 2015/863.

The full text of the EU declaration of conformity is available at the following internet address: <https://www.horizonhobby.com/content/support-render-compliance>.

**F-14 Tomcat Twin 40mm EDF (EFL01450) Wireless Frequency Range and Wireless Output Power:** 2404-2476 MHz / 1.43 dBm

### EU Manufacturer of Record:

Horizon Hobby, LLC  
2904 Research Road  
Champaign, IL 61822 USA

### EU Importer of Record:

Horizon Hobby, GmbH  
Hanskampring 9  
22885 Barsbüttel Germany

### WEEE NOTICE:



This appliance is labeled in accordance with European Directive 2012/19/EU concerning waste of electrical and electronic equipment (WEEE). This label indicates that this product should not be disposed of with household waste. It should be deposited at an appropriate facility to enable recovery and recycling.





© 2021 Horizon Hobby, LLC.

E-flite, AS3X, DSM, DSM2, DSMX, Bind-N-Fly, BNF, the Bind-N-Fly logo, SAFE, the SAFE logo, ModelMatch, EC3, IC3, and the Horizon Hobby logo are trademarks or registered trademarks of Horizon Hobby, LLC. The Spektrum trademark is used with permission of Bachmann Industries, Inc. All other trademarks, service marks and logos are property of their respective owners.

US 9,056,667. US 8,672,726. US 9,753,457. US 10,078,329. US 9,930,567. US 10,419,970. US 10,849,013.

<https://www.horizonhobby.com>