

# F-16 FIGHTING FALCON USER MANUAL

Wingspan:878mm

Item No.: FJ211

Version No.: FJ211-V01



EN

1~ 12

中

13~24

**Freewing** M<sup>3</sup>DEL<sup>®</sup>

[www.sz-freewing.com](http://www.sz-freewing.com)



MADE IN CHINA



The F-16C "Fighting Falcon" was originally developed for the United States Air Force (USAF) as an air superiority day fighter, but it eventually evolved into a successful all-weather multi-role aircraft. The F-16C features an internal M61 Vulcan cannon and multiple locations for mounting weapons and other mission-specific equipment. Operating in nearly 30 countries to this day, the F-16 has distinguished its place in aviation history.

Freewing has modeled this brilliant EPO foam aircraft around a 70mm electric ducted fan (EDF) powerplant. With a 1306mm length and 878mm wingspan, this 1/12 scale flying replica includes many exciting features! An accurate scale outline with sharp surface details and panel lines will make this model stand out at your airfield. Removable main wings and a magnetic nose cone make transport very convenient. The cockpit battery bay cover is secured with a sliding latch to prevent separation during flight, and the entire aircraft is reinforced with strategic placement of carbon fiber tubes to withstand vigorous flying maneuvers.

Our Freewing 70mm F-16C V2 model jet uses electric retractable landing gear for lower drag and better scale appearance during flight. The model is offered in three different powerplant options: 4s Standard, 6s Upgrade, and 6s Professional. These powerplants achieve a maximum flying speed of 125kph, 140kph, and 165kph, respectively. The aircraft is designed for stability, strong climbing performance, and short takeoff distance, suitable for all levels of jet pilots. The aircraft can also maintain a high alpha of 30 degrees to demonstrate its superior low speed stability.

We feature this exciting aircraft in the modern three tone gray US Air Force base colors as well as an Arctic Camo paint scheme, and three decal sets are included for you to choose from to customize your model from various actual Air Force squadrons.

**⚠ NOTE:** This is not a toy. Not for children under 14 years. Young people under the age of 14 should only be permitted to operate this model under the instruction and supervision of an adult. Please keep these instructions for further reference after completing model assembly.

## Note:

1. This is not a toy! Operators should have some basic experience. Beginners should operate only under the guidance of a professional instructor.
2. Before beginning assembly, please read through the instructions and carefully follow them throughout the build.
3. Freewing and it's vendors will not be held responsible for any losses due to improper assembly and operation.
4. Model airplane operators must be at least 14 years of age.
5. This airplane is made of EPO foam material, covered with surface spray paint. Don't use chemicals to clean as it may cause damage.
6. You should avoid flying in areas such as public places, areas with high voltage power lines, nearby highways, airports or in other areas where laws and regulations clearly prohibit flight.
7. Do not fly in bad weather conditions, including thunderstorms, snow, etc...
8. Lipo batteries should be properly stored in a fire proof container and be kept at a minimum of 2M distance away from flammable or explosive materials.
9. Damaged or scrap batteries must be properly discharged before disposal or recycling to avoid spontaneous combustion and fire.
10. At the Flying Field, properly dispose of any waste you have created, don't leave or burn your waste..Ensure that your throttle is in the low position and that your radio is turned on before connecting the Lipo battery.
- 11.Ensure that the throttle is in the lowest position and transmitter switch on, before connecting a Lipo Battery to the ESC of the aircraft.
12. Do not try to catch the airplane while in flight or during landing. Wait for the airplane to come to a complete stop before handling.

## Index

<b>Introduction</b>	<b>1</b>	<b>Control board Instruction</b>	<b>8</b>
<b>Product basic parameters</b>	<b>2</b>	<b>Motor parameters</b>	<b>8</b>
<b>Parts List</b>	<b>2</b>	<b>Powersystem installation Instructions</b>	<b>9</b>
<b>PNP Assembly Instructions</b>	<b>3</b>	<b>Battery Installation</b>	<b>10</b>
<b>Servo Installation Instructions</b>	<b>5</b>	<b>Center of Gravity</b>	<b>10</b>
<b>Landing ear Installation Instructions</b>	<b>6</b>	<b>Control surface diagram</b>	<b>11</b>
<b>Servo parameters</b>	<b>7</b>	<b>Dual rates</b>	<b>12</b>

## Product basic parameters

eN



### Standard version

Wing loading : 121g/dm<sup>2</sup>  
 Motor: 2849-2850KV(4S)  
 brushless outrunner motor  
 Ducted fan: 70mm 12-blade ducted fan  
 Flight speed: 125km/h  
 ESC: 60A brushless ESC  
 Servo: 9g digit plastic servo(6pcs)  
 Weight: 1400g (without battery)  
 Thrust: 1500g

### Upgrade version

Wing loading:145g/dm<sup>2</sup>  
 Motor: 3048-2150KV(6S)  
 brushless outrunner motor  
 Ducted fan: 70mm 12-blade ducted fan  
 Flight speed: 140km/h  
 ESC: 60A brushless ESC  
 Servo: 9g digit metal gear servo (6pcs)  
 Weight: 1450g (without battery)  
 Weight: 2150g (without battery)

### Professional version

Wing loading:145g/dm<sup>2</sup>  
 Motor: 3048-2300KV(6S)  
 brushless outrunner motor  
 Ducted fan: 70mm 12-blade ducted fan  
 ESC: 80A brushless ESC  
 Servo: 9g digit metal gear servo(6pcs)  
 Flight speed: 165km/h  
 Weight: 1450g (without battery)  
 Weight: 2400g (without battery)

**Note:** The parameters stated here are derived from test results using our accessories.

if you use other accessories, the test results will differ. We cannot provide technical support if you have a problem when using other accessories.

The kit doesn't include the optional missiles and pylons, if you wish to have them, please contact your local dealer.

## Parts List

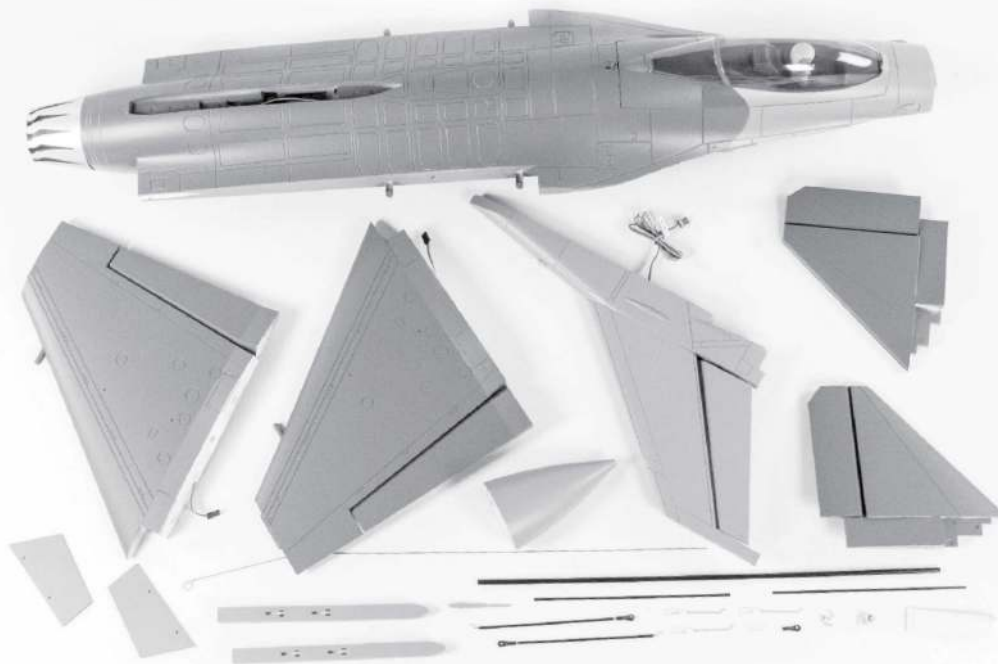

Different types of kits will come with certain specific parts. Refer to the list of parts for your type of kit in the chart below.

NO.	Parts Name	PNP	KIT Plus	Airframe	NO.	Parts Name	PNP	KIT Plus	Airframe
1	Fuselage	Pre-install power system and servos	Pre-installed servo	No electronic equipment	6	Missiles and pylons	Optional part, purchase separately	Optional part, purchase separately	Optional part, purchase separately
2	Main wing	Pre-installed all electronic parts	Pre-installed servo	No electronic equipment	7	Pushrod	✓	✓	✓
3	Vertical tail	Pre-installed all electronic parts	Pre-installed servo	No electronic equipment	8	Carbon Fiber tube	✓	✓	✓
4	Horizontal tail	✓	✓	✓	9	Glue/Decals	✓	✓	✓
5	Nose cone, Fln	✓	✓	✓	10	Manual	✓	✓	✓

## Main wing assembly

1. Insert the carbon tube into fuselage.

Carbon tube ( Ø6x500mm )

2. Connect the main wing servo cable and fuselage extension cable, then install left/right main wing.

main wing trough port

3. Use 4pcs screws to fix the main wing.

Screw ( PWA3x8 4pcs )

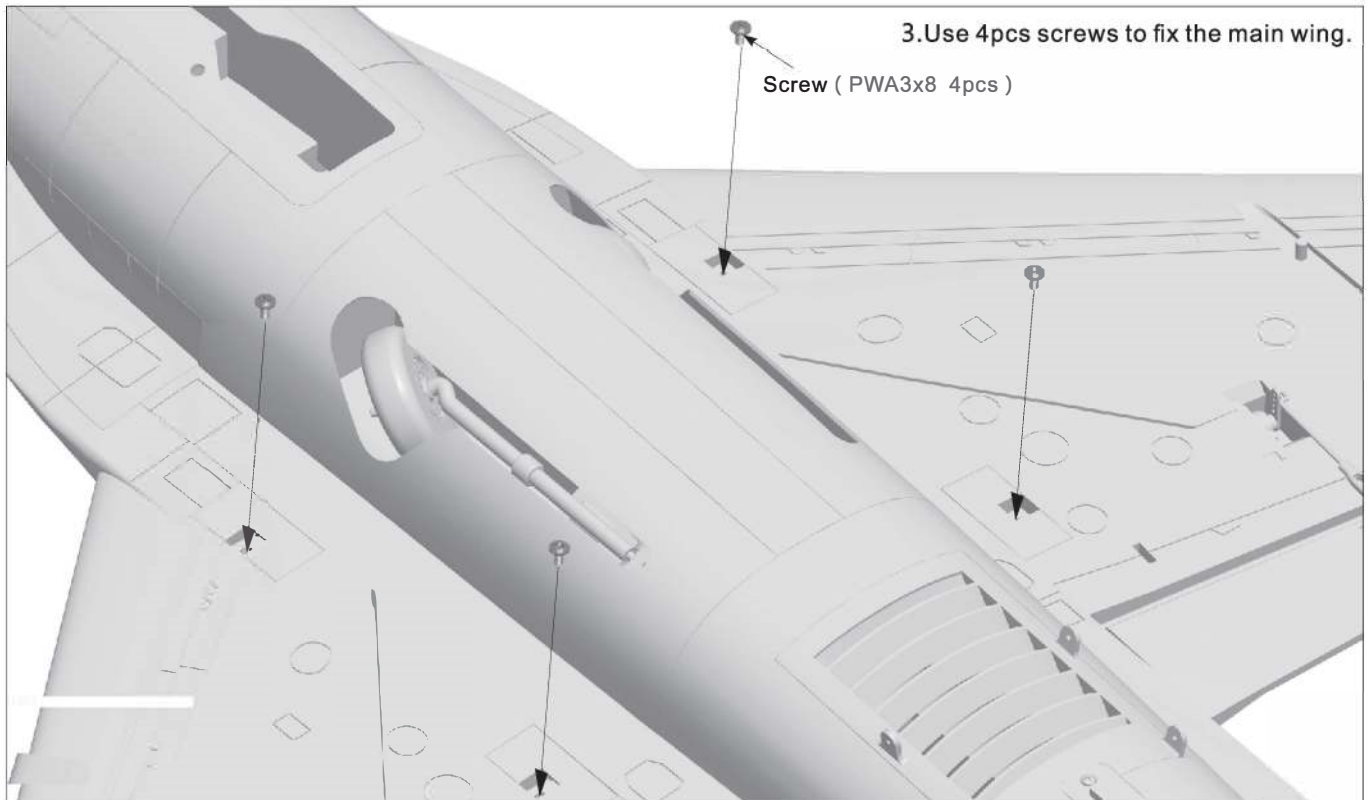

## Horizontal Stabilizer Assembly

Referring to the photo:

1. Use the provided glue to attach the horizontal stabilizer to the tail of the fuselage.
2. Use glue to attach the carbon rod into the trough for additional strength.
3. Repeat the above steps for the other side.

A-Tail fuselage  
B-Horizontal tail  
C-Carbon piece

Note: Please use the provided EPO glue. For best results, glue should be spread evenly, then wait for 90 seconds before assembly

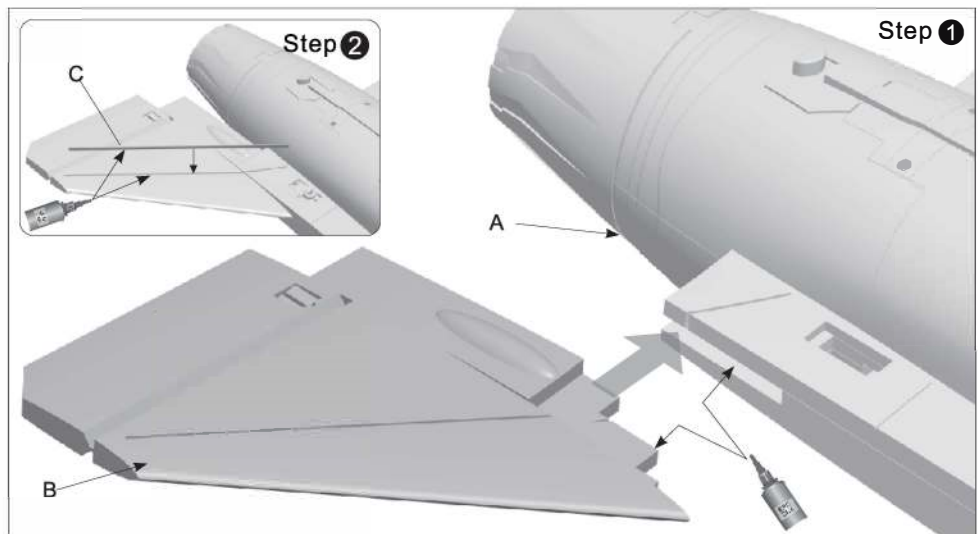



## Vertical Stabilizer Assembly

1. Feed the rudder servo cable into the trough.
2. Use glue to attach the vertical tail.

A-Vertical tail  
B-Trough  
C-Servo cable

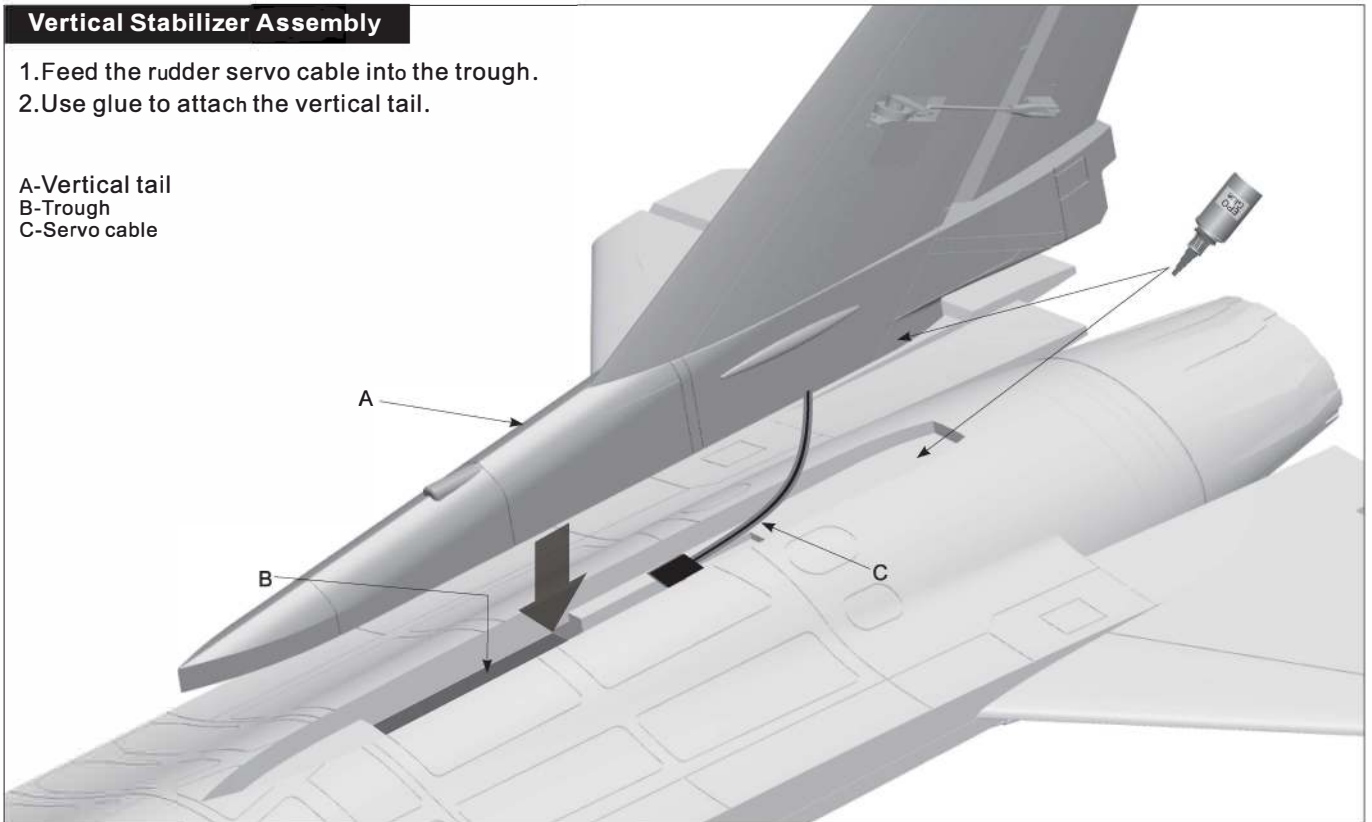

## Missile and Pylon Installation

(Note: This kits does not come with missiles and pylons. Contact your local dealer to purchase them.)

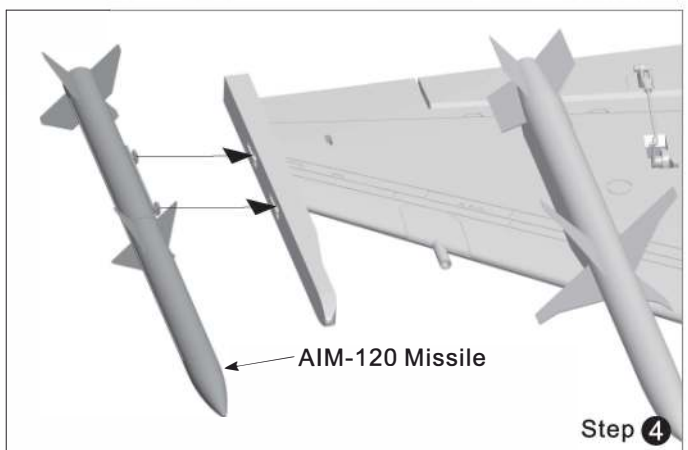
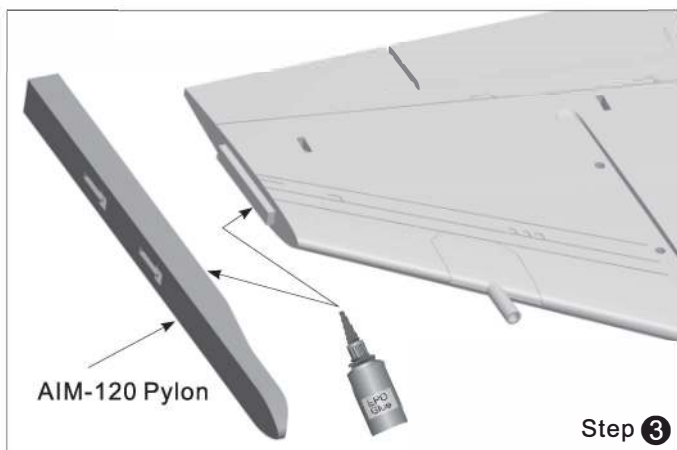
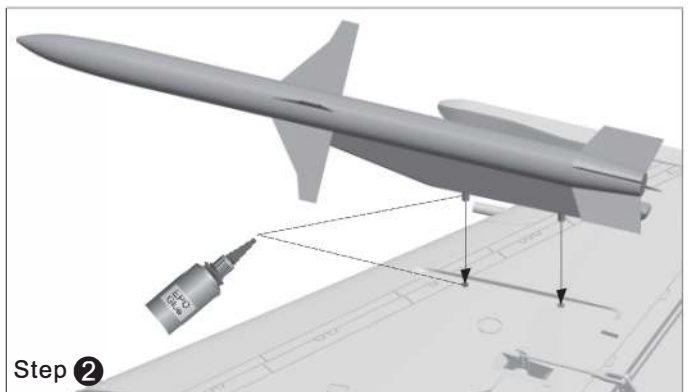
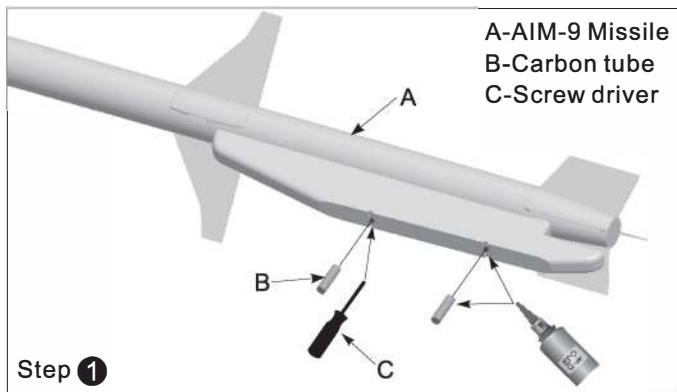

# Introduction to Servo Installation

EN

## Main wing servo Installation

1. Use a servo tester or radio to center the servo arm.
2. Use glue to install the servo and aileron horn to the main wing.
3. Feed the servo cable through the trough, after the servo is installed, apply the decal.
4. Insert one end of the pushrod to the servo arm and adjust its length. Then snap the clevis to the aileron horn.
5. Repeat the above four steps for the other wing.

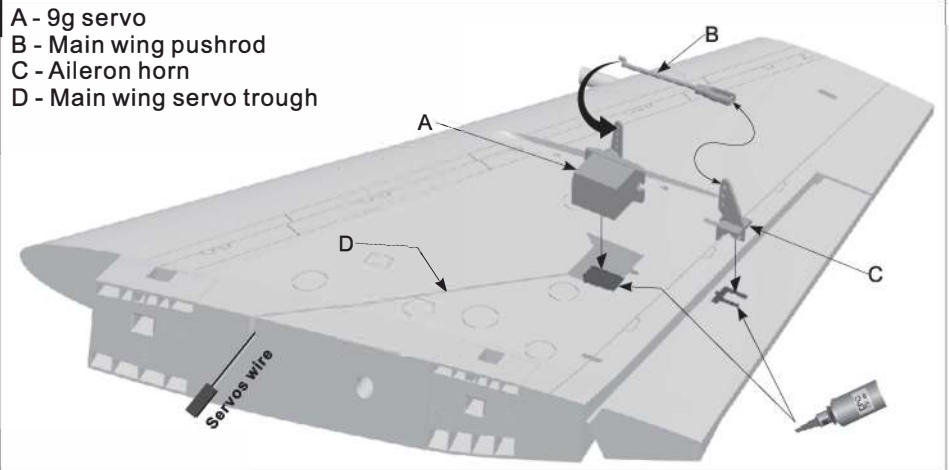

## Elevator servo Installation

1. Use a servo tester or radio to center the servo arm.
2. Use glue to install the servo and control horn to the elevator.
3. Feed the servo cable through the trough.
4. Inset one end of the pushrod to the servo arm and adjust its length. Then snap the clevis to the elevator control horn.
5. Repeat the above four steps for the other elevator

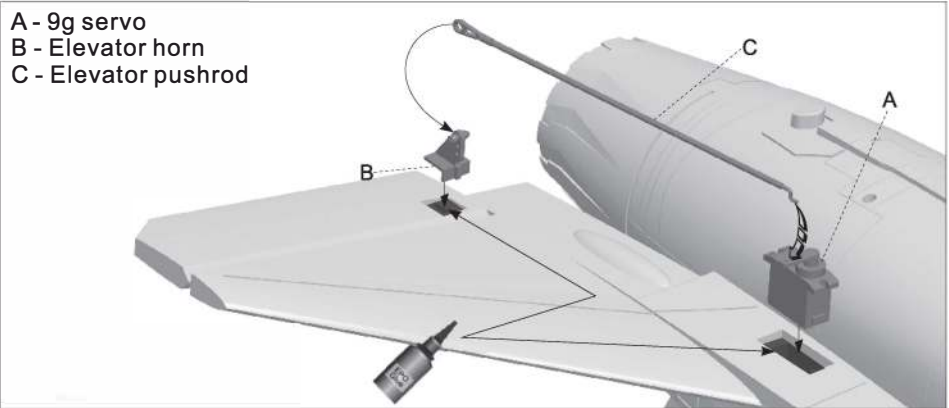

## Rudder servo Installation

1. Use a servo tester or radio to center the servo arm.
2. Use glue to install the servo and servo arm to the rudder.
3. Feed the servo cable through the trough.
4. Insert one end of the pushrod to the servo arm and adjust its length. Then snap the clevis to the rudder control horn.

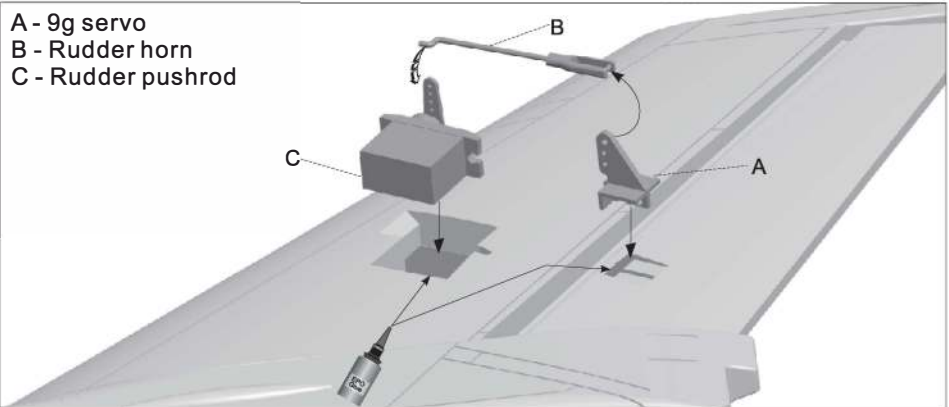

### Aileron pushrod size

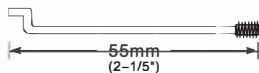

Pushrod diameter Ø1.2mm

### Aileron pushrod mounting hole



### Elevator pushrod size

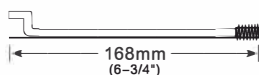

Pushrod diameter Ø1.5mm

### Elevator pushrod mounting hole



### Rudder pushrod size



Pushrod diameter Ø1.2mm

### Rudder pushrod mounting hole



# Landing gear Installation Instructions

EN

## Nose landing gear Assembly

Please refer to the following diagram to assemble, replace or revise the nose landing gear.

### sparepart name and parameters

- |                            |                                |   |
|----------------------------|--------------------------------|---|
| A- Grub screws (M3x3 1pcs) | H- Nose gear steering rod      | N- Screw (KA2.6x12 4pcs)                |
| B- Wheel lock              | I - Metal trunion              | O- Nose gear metal reinforcement plate. |
| C- Wheel                   | J - C clip (Ø2.0mm 1pc)        | P - Assembled Nose gear                 |
| D- Nose gear main strut    | K- Servo plastic cover(left)   | Q-Servo                                 |
| E- Steering arm tiller     | L - Servo plastic cover(right) | R-Screw (PWA2.0x8 2pcs)                 |
| F- Grub screw (M3x3)       | M- Screw (PA1.7x8 2pcs)        | S - Steering pushrod                    |
| G- Nose gear steering ring | M1- Screw (PB1.0x10 3pcs)      | T-Nose gear cover                       |

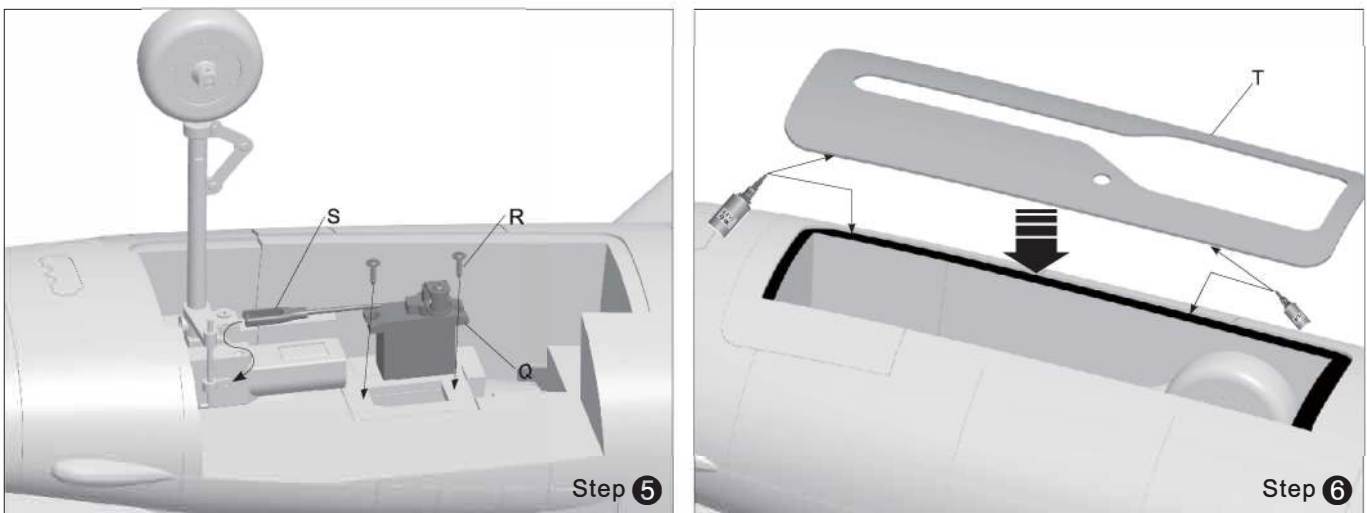
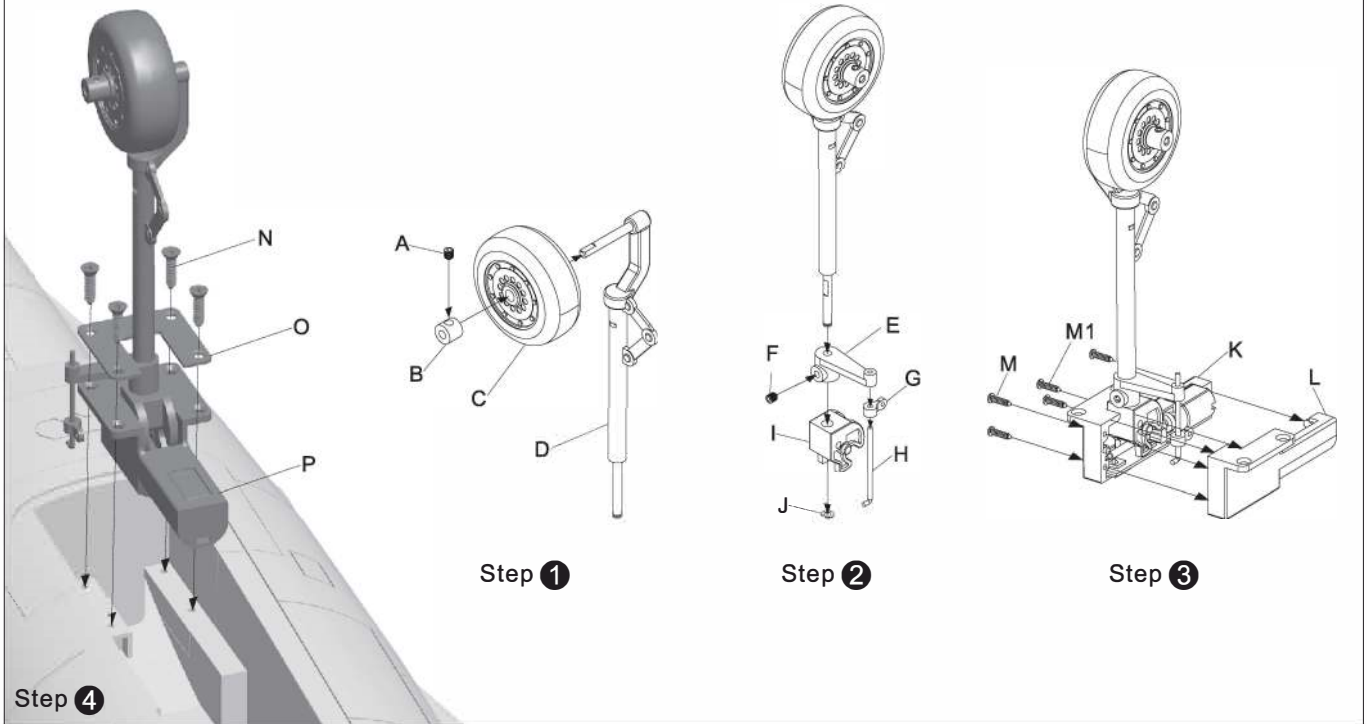

Nose steering pushrod size



Pushrod diameter : Ø1.2mm



**Note:** Ensure that the flat side of the gear shaft is facing towards the screw hole before tightening the grub screw in order to ensure that the gear is both anchored and facing in the proper direction. Failure to do so may result in the the gear coming loose and falling off.

# Landing gear Installation Instructions

EN

## Main landing gear Installation

Please assemble and disassemble the main landing gear with reference to the following photo and diagrams.

A-Grub screw (M3x3 1pc).

B-Wheel lock.

C-Wheel.

D-Rear gear main strut.

E- Electric landing gear retract.

F-Grub screw (M3x3 2pcs).

G-Assembled Main Landing Gear.

H-Metal reinforcement plate.

I -Screw (KA2.6x12 8pcs)

J -Main Gear cover.

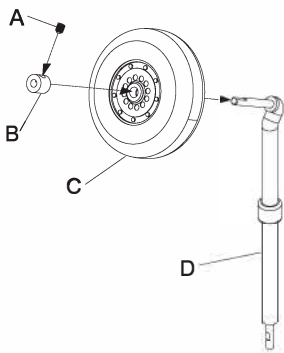

Step 1

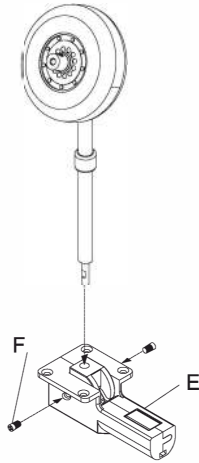

Step 2

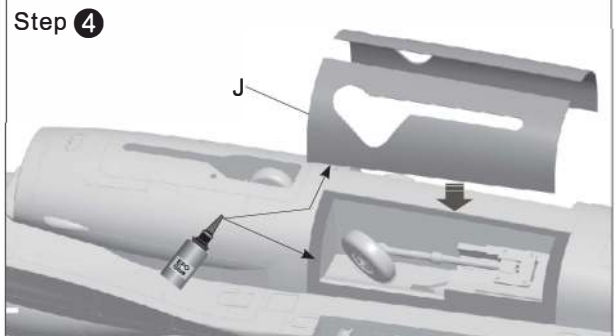
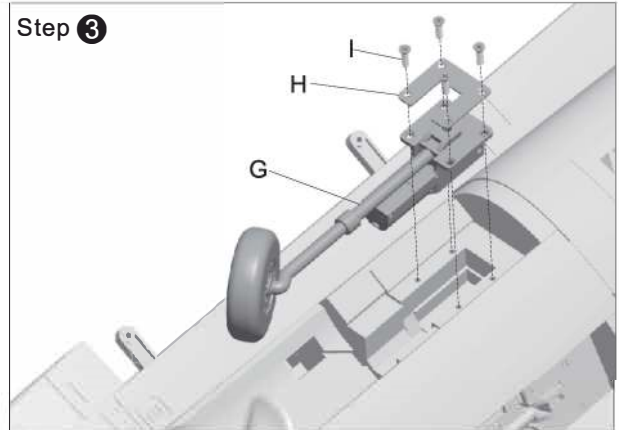

## Servo parameters

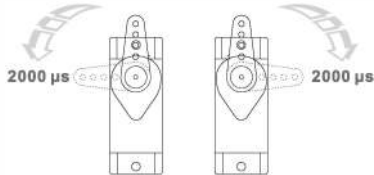

A servo or reversed servo is defined as follows:  
When the servo input signal changes from 1000μs to 2000μs, if the servo arm rotates clockwise, it's a positive servo. If it rotates counter clockwise, it's a reversed servo.

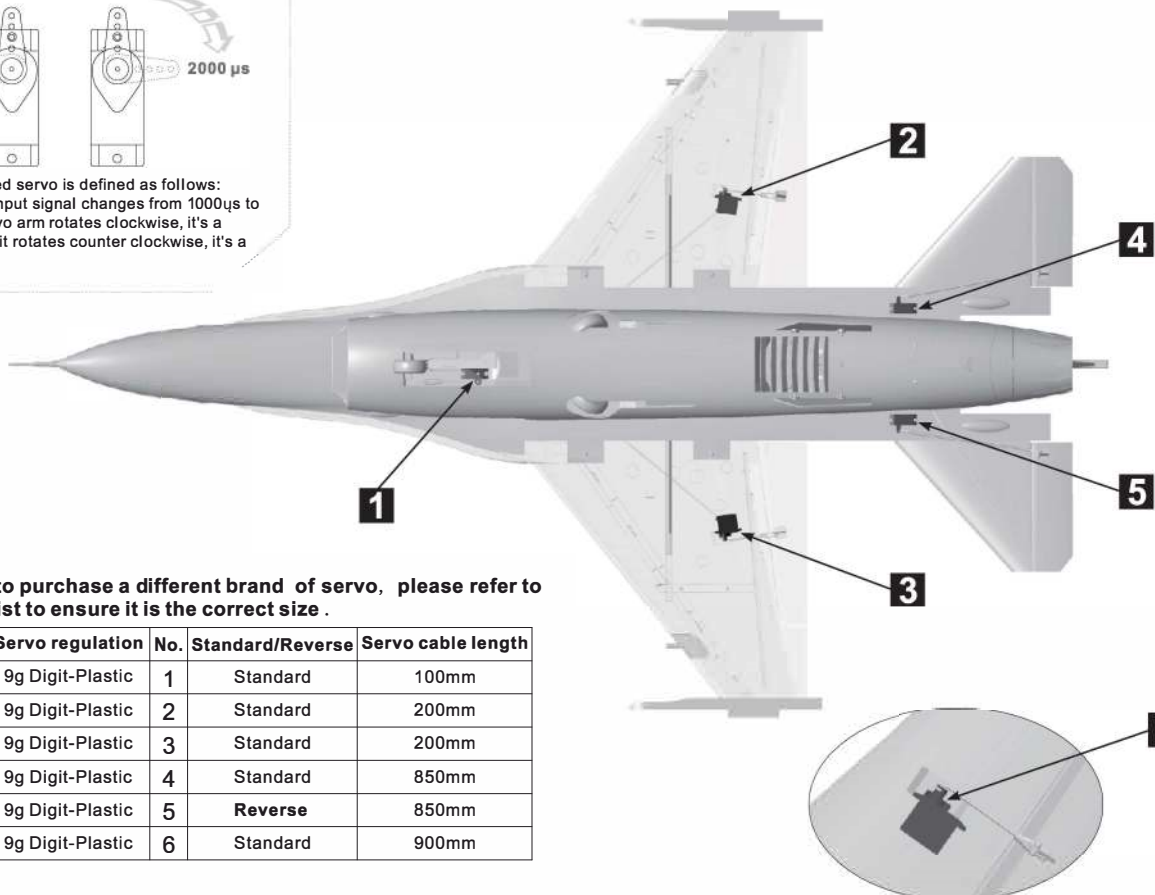

If you choose to purchase a different brand of servo, please refer to the following list to ensure it is the correct size .

Servo position	Servo regulation	No.	Standard/Reverse	Servo cable length
Nose steering	9g Digit-Plastic	1	Standard	100mm
Left aileron	9g Digit-Plastic	2	Standard	200mm
Right aileron	9g Digit-Plastic	3	Standard	200mm
Left elevator	9g Digit-Plastic	4	Standard	850mm
Right elevator	9g Digit-Plastic	5	<b>Reverse</b>	850mm
Rudder	9g Digit-Plastic	6	Standard	900mm



# Control board instruction

EN

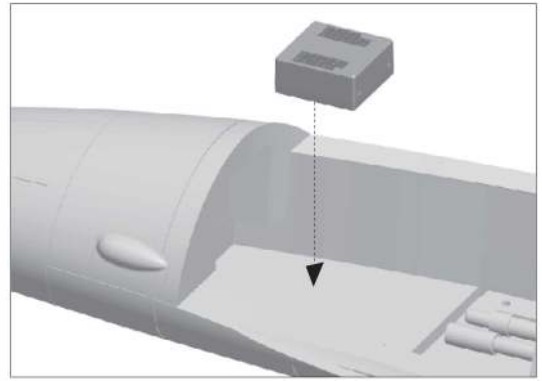
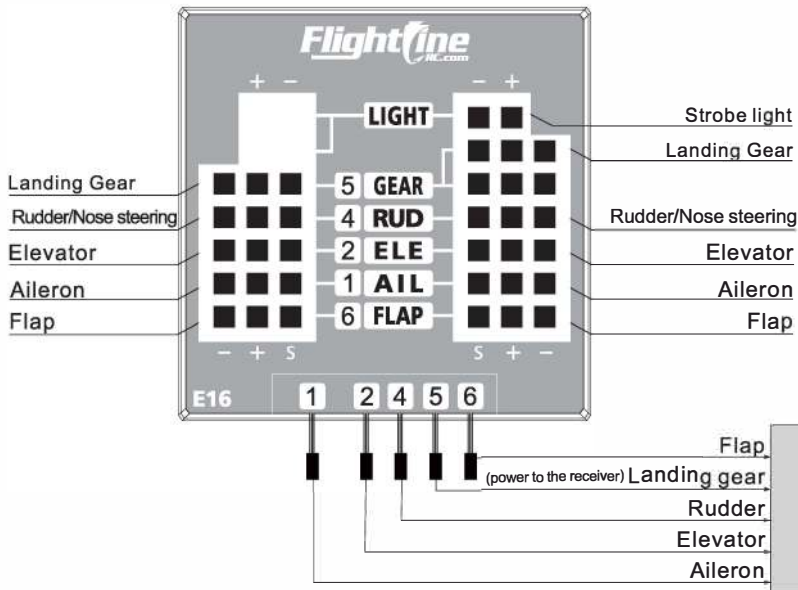

Connect all the control surfaces listed on the control board to the control board. All others will be connected directly to the receiver.

# Motor parameters

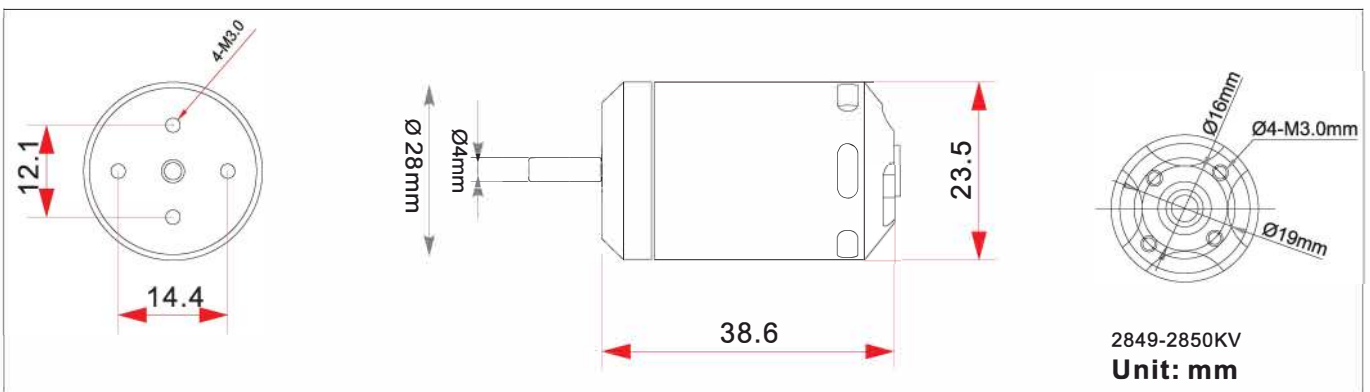
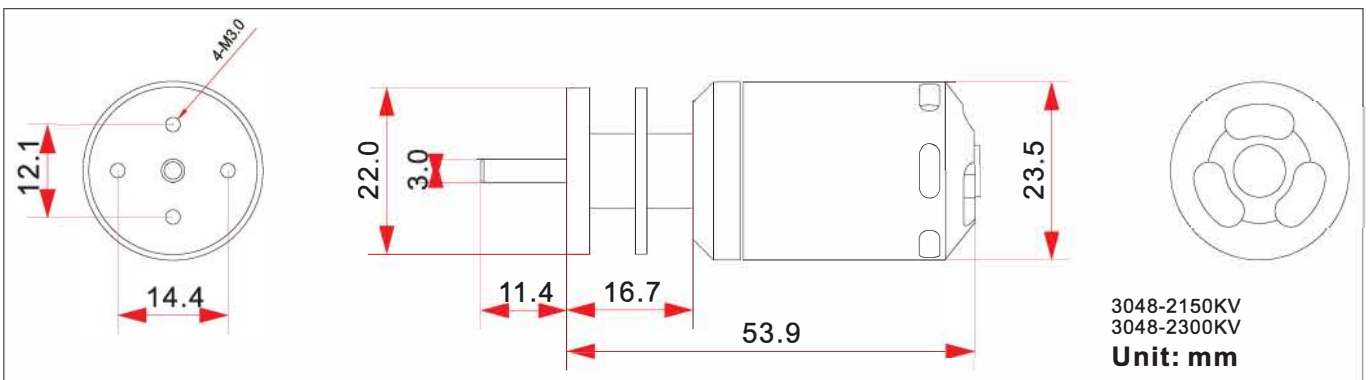

Item No.	EDF Fans	Voltage (V)	Current (A)	Power (W)	Thrust (Kg)	Efficiency (g/w)	Motor Specifications	Rotating speed (rpm)	Weight (g)
E7215	70mm 12-blade EDF	14.8	55-60	880	1.5-1.6	1.76	2849-2850	42000	146
E7216	70mm 12-blade EDF	22.2	55-60	1330	2.05-2.25	1.65	3048-2150	47700	180.7
E7217	70mm 12-blade EDF	22.2	65-72	1510	2.3-2.5	1.6	3048-2300	51000	180.7

## Standard version

- A - 2849-2850KV Brushless outrunner motor
- B - 70mm Outrunner ducted frame
- C - Screw (PWM3x6 4pcs)
- D - Motor chuck
- E - Motor chuck fixed plate
- F - 70mm 12-blade ducted fan
- G - Spacer
- H - Nut
- I - Spinner
- J - Screw (M3x8 1pc)

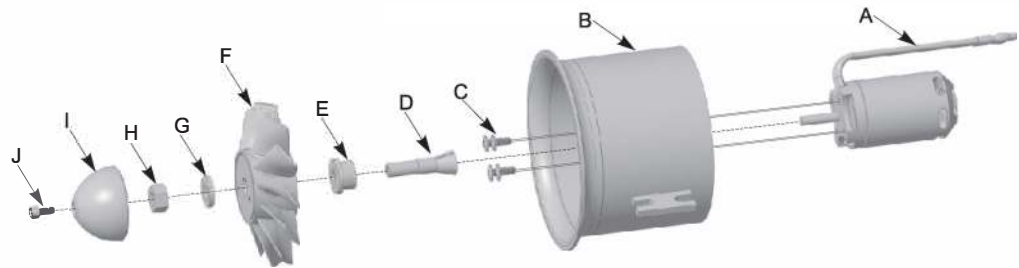

## Upgrade version

- A - 3048-2150KV Brushless outrunner motor
- B - 70mm Outrunner ducted frame
- C - Screw (PWM3x6 4pcs)
- D - Motor chuck
- E - Motor chuck fixed plate
- F - 70mm 12-blade ducted fan
- G - Spacer
- H - Nut
- I - Spinner
- J - Screw (M3x8 1pc)

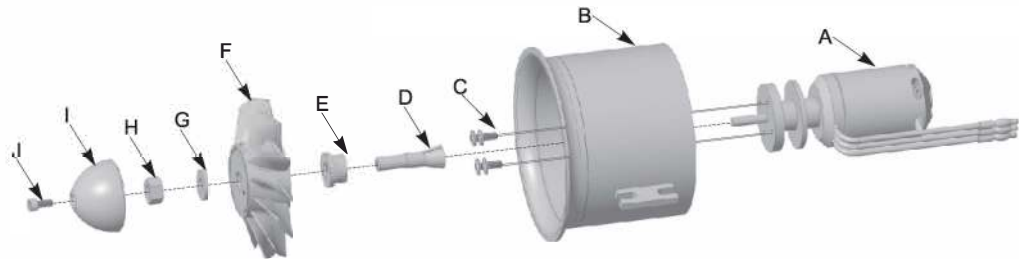

## Professional version

- A - 3048-2300KV Brushless outrunner motor
- B - 70mm Outrunner ducted frame
- C - Screw (PWM3x6 4pcs)
- D - Motor chuck
- E - Motor chuck fixed plate
- F - 70mm 12-blade ducted fan
- G - Spacer
- H - Nut
- I - Spinner
- J - Screw (M3x8 1pc)

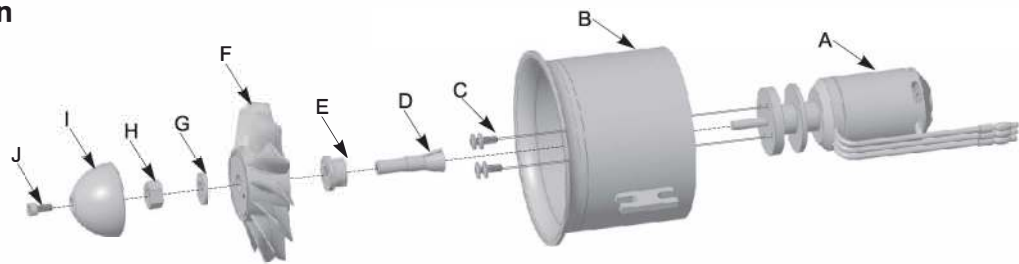

**⚠** When the E SC is connected to the battery, to not touch the E SC or motor to avoid serious injury.  
When testing the EDF, use a test stand for safety.

**Refer to the following diagram to install the ESC and power system:**

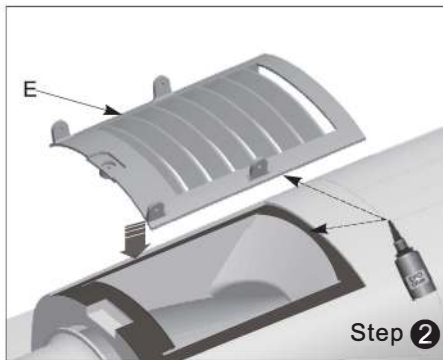
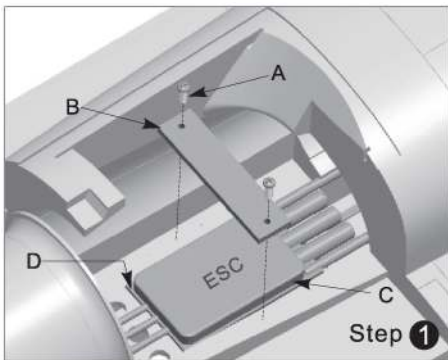

- A - Screws (PA3x25 2pcs)
- B - ESC fixed wood piece 1
- C - ESC
- D - ESC fixed wood piece 2
- E - Intake grid
- F - Screws (PWA3x8 4pcs)
- G - 70mm EDF power system
- H - Screws (KA2.6x8 3pcs)
- I - EDF cover
- J - Screws (KA2.6x8 4pcs)
- K - Flt

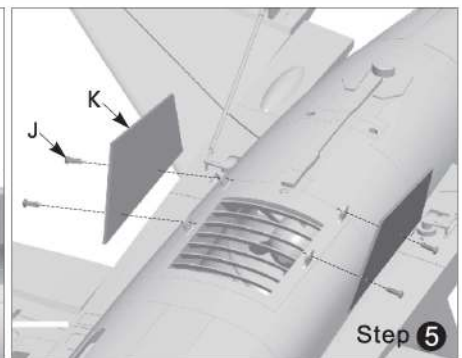
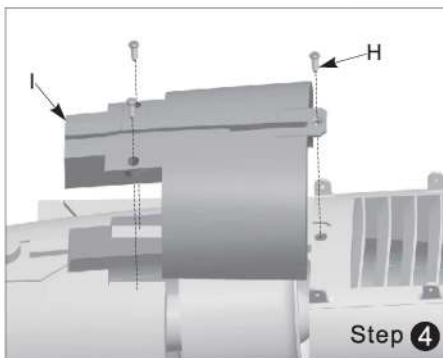
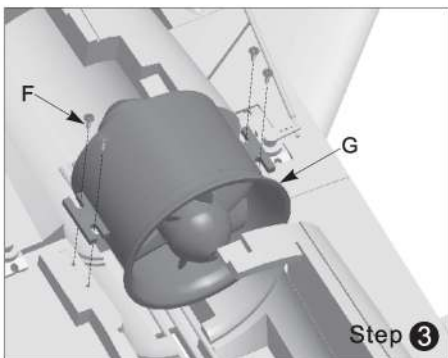

## Battery Installation

EN

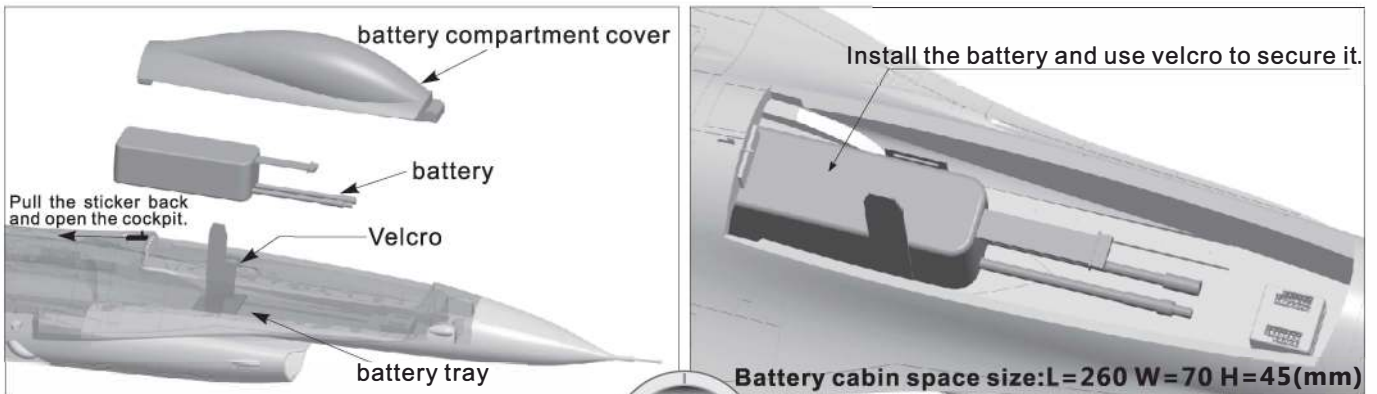

Before connecting the battery to the ESC, please switch on the transmitter and make sure the throttle is in the lowest position. Use the kill switch if you have one assigned.



The battery capacity and discharge rate we advise to use are as follows:

**4S 14.8V 2600~4000mAh**

**6S 22.2V 2600~4000mAh**

discharge rate  $\geq 30C$

## Center of Gravity

The correct center of gravity is directly related to the success of the flight, please refer to the following CG diagram to adjust your plane's center of gravity.

- You can move the battery forward or backward to adjust the center of gravity.
- If you can not adjust the CG by moving the battery, you can also use some other suitable material such as sticky backed weight to counterweight. It's highly important to make sure that CG is in the correct position, especially for the first few flights.
- Afterwards, you can adjust it to suit your individual taste.

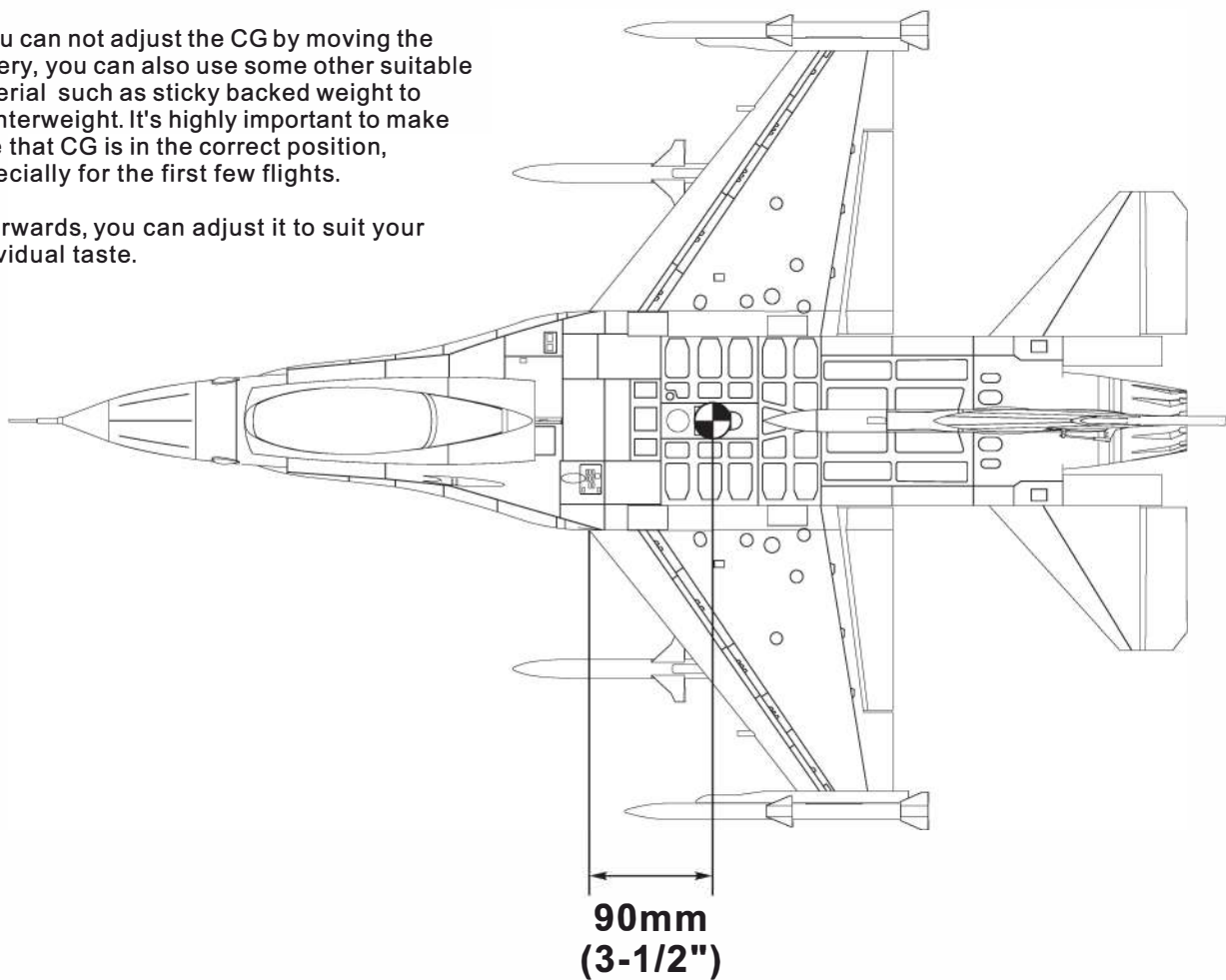

## Control direction test

EN

After the airplane is completely assembled but before the first flight, turn on your radio and ensure that the throttle is in the lowest position, engage the kill switch if you have one assigned. Connect a fully charged battery to the ESC, then use your radio to test and ensure that every control surface is moving in the correct direction.

### Aileron

Stick Left

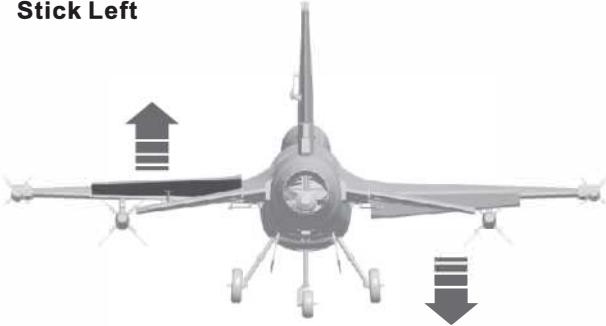

Stick Right

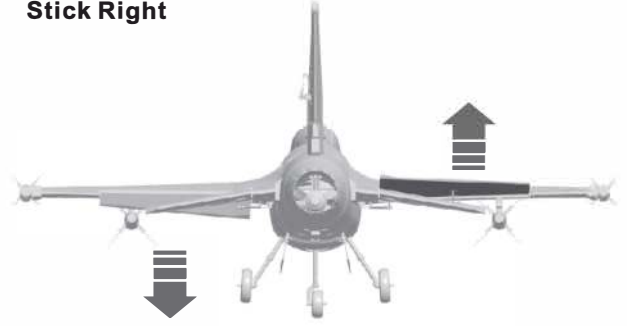

### Elevator

Stick Back

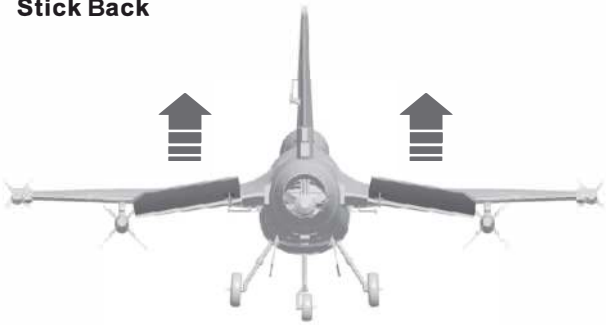

Stick Forward



### Rudder

Stick Left



Stick Right

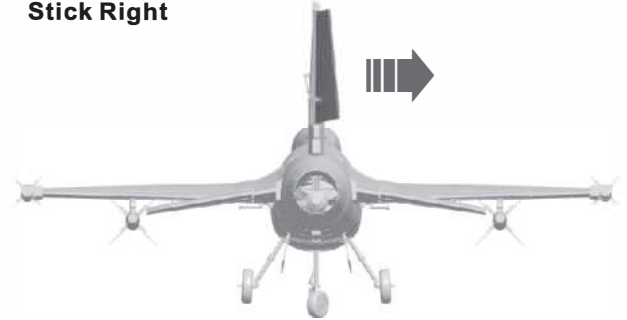



According to our test results, the following rates proved to be a good starting point. Low rates are good for initial flights or less experienced pilots. High Rates will be more sensitive to control inputs After initial flights, adjust the rates to suit your own style.

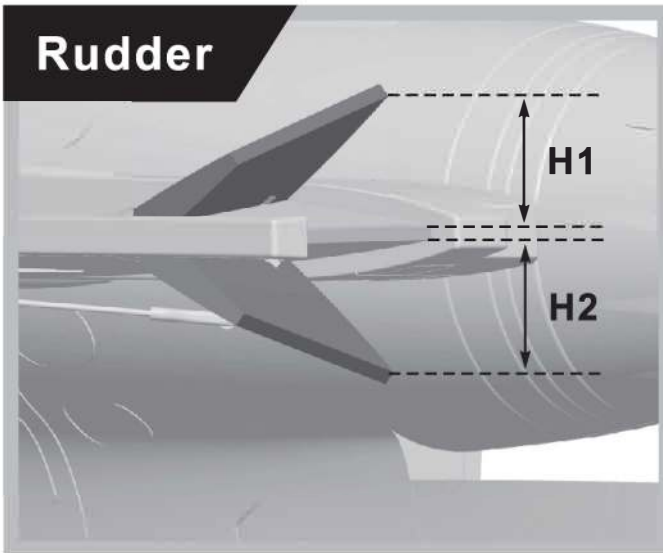
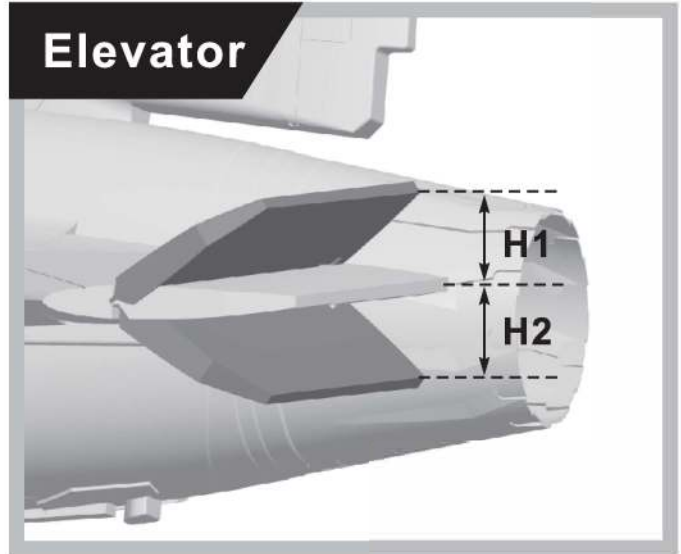
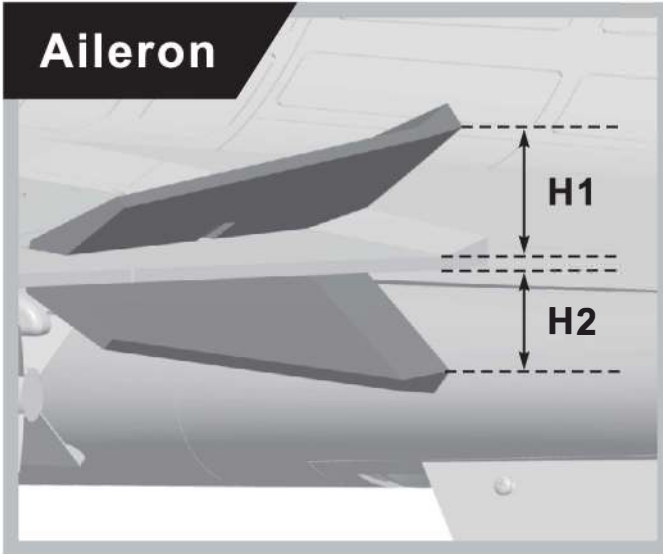

Note: carefully check to see if there are any movements from the other control surfaces when you move your control sticks, say, the ailerons move when you pull up elevator. If so, you can adjust the expo until only the control surface you engage moves.

	Aileron	Elevator	Rudder
<b>Low Rates</b>	H1/H2 22mm/22mm D/R Rate: 65%	H1/H2 19mm/19mm D/R Rate: 80%	H1/H2 30mm/30mm D/R Rate: 85%
<b>High Rates</b>	H1/H2 34mm/34mm D/R Rate: 100%	H1/H2 23mm/23mm D/R Rate: 100%	H1/H2 35mm/35mm D/R Rate: 100%



**Dongguan Freewing Electronic Technology Ltd**  
**HK Freewing Model International Limited**

Add.: FeiYi Building, face to Labor Bureau, Fumin Middle Road, Dalang Town,  
Dongguan City, Guangdong Province, China

Web: <http://www.sz-freewing.com>

Email: [freewing@sz-freewing.com](mailto:freewing@sz-freewing.com)

Tel: 86-769-82669669 Fax: 86-769-82033233

**东莞市飞翼电子科技有限公司**  
**香港飞翼模型国际有限公司**

地址: 广东省东莞市大朗镇富民中路402-408号飞翼楼四楼

Web: <http://www.sz-freewing.com>

Email: [freewing@sz-freewing.com](mailto:freewing@sz-freewing.com)

Tel: 86-769-82669669 Fax: 86-769-82033233

