

PKZ4276



ParkZone® products are distributed exclusively by  
Horizon Hobby, Inc.  
4105 Fieldstone Road  
Champaign, IL 61822  
©2006 Horizon Hobby, Inc.  
[www.parkzone.com](http://www.parkzone.com)





**F-27C**

# **STRYKER™**

***Instruction Manual***



**PLUG-N-PLAY™**



***Charge-and-Fly Park Flyer***

Wingspan: 37 in (950mm)  
Length: 27 in (700mm)  
Weight: 22 oz (620 g)

Motor: 6-pole brushless direct-drive, 1880Kv  
Speed Control: E-flite 25A brushless ESC  
Wing: Z-Foam™  
Prop: 6x4

# F-27C Stryker Plug-N-Play Instruction Manual

Congratulations on your purchase of the ParkZone® F-27C Stryker™ Plug-N-Play™ airplane. Your F-27C Stryker PNP comes almost fully assembled so you can get in the air quickly. It already has two 3-wire servos installed, along with a ParkZone 6-pole 1880Kv brushless motor and E-flite® 25 amp ESC. You only need to add your own 72MHz FM transmitter, with four or more channels, a receiver, and a 3S Li-Po battery pack. The minimum recommended discharge rate for the battery pack is 12C. We recommend ParkZone's 3S 2200mAh Li-Po pack (PKZ1030).

Everyone at ParkZone is committed to giving you the most enjoyable flying experience possible. In order to ensure safe and successful flight, we ask that you do not fly until you have read these instructions thoroughly.

## **Warning: WE KNOCKED THIS ONE OUT OF THE PARK**

This is a high-performance airplane and is not a toy. The F-27C Stryker PNP is capable of flying at speeds exceeding 80 miles per hour (129 kilometers per hour), so it is intended for highly experienced and expert radio control pilots only. We suggest that this airplane only be flown at AMA approved flying sites. It travels much too fast to be flown in a typical park setting, even one with many acres of space. Never fly where you may place anyone's safety in jeopardy. **Crash damage is not covered under any warranty.**

## ASSEMBLING YOUR F-27C STRYKER PNP

### **Step 1** Attaching the Nose

1. Trial fit the nose without peeling away the paper covering the tape. This will give you a good idea as to what the fit will be.
2. Peel the paper off the tape and carefully attach the nose.
3. To add support, apply the included decals to the side and bottom of the nose/fuselage

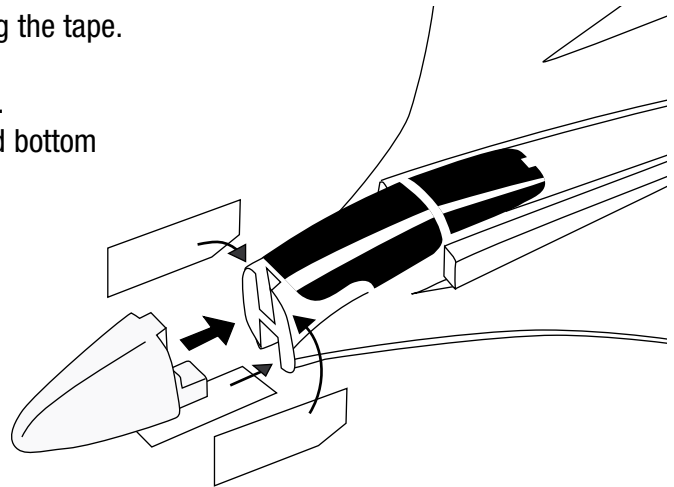

## Step 2

### Attaching the Vertical Fins

1. Slide the fins into the slots on the fuselage. The leading edge of the fin should fit under the retainer that is already secured in the fuselage.
2. Confirm that the fit is tight and both fins are secured properly.

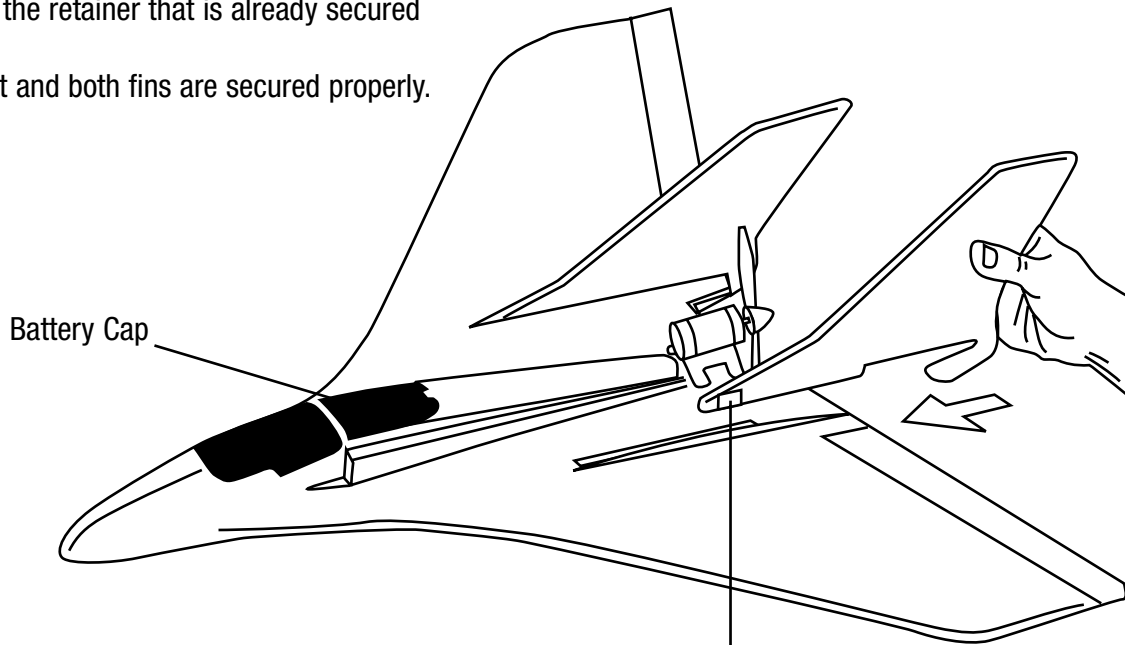

**Note:** It may be helpful to add a few drops of CA to the front tips of the vertical stabs in order to keep them in place while flying your F-27C Stryker PNP. There is rubber double-sided tape on the front of each one, but over time, and despite a tight tension fit when you slide the fins on the first time, they can lose their sticking power. At speeds exceeding 80 mph, it is good, for your safety and the safety of your plane, to add CA to ensure they will stay in place.

## Step 3

### Installing Your Receiver

Your F-27C Stryker PNP requires, at minimum, a 3-Channel FM 72MHz radio system, and utilizes elevons that control pitch and roll. The E-flite 25A brushless ESC that comes already installed in your F-27C Stryker PNP controls throttle.

1. Plug the ESC lead into the Throttle channel of your receiver.
2. Consult your radio instructions for the set-up for elevons/"V" tail control.

Make certain to carefully route the receiver antenna from the receiver through the bottom of the left wing. There is a small cavity molded in the foam for the purpose of running the antenna through (just behind the carbon spar in the wing). Make sure the antenna exits the bottom left wing tip so there is at least 14 inches (35.5 cm) of the antenna hanging from the plane to ensure the range will be sufficient.

**Note:** Always make certain that you perform a proper range check prior to your first flight and after you have made any change to your receiver and/or transmitter.

# PREPARING TO FLY

## Step 1 Setting Aileron and Elevator Throws

The throws that we recommend you set-up for low rate are:  
Ailerons: +/- 7/16 inches (11mm)  
Elevator: +/- 3/8 inches (9mm)

The throws that we recommend you set-up for high rate are:  
Ailerons: +/- 5/8 inches (16mm)  
Elevator: +/- 1/2 inches (12mm)

**Note:** When you are looking from the tail of the aircraft and

you give right aileron command, the right elevon should deflect upward, while the left deflects downward (and vice versa).

When pulling the elevator stick back, the elevons should both deflect upward. When pushing the elevator stick forward, the elevons should both deflect downward

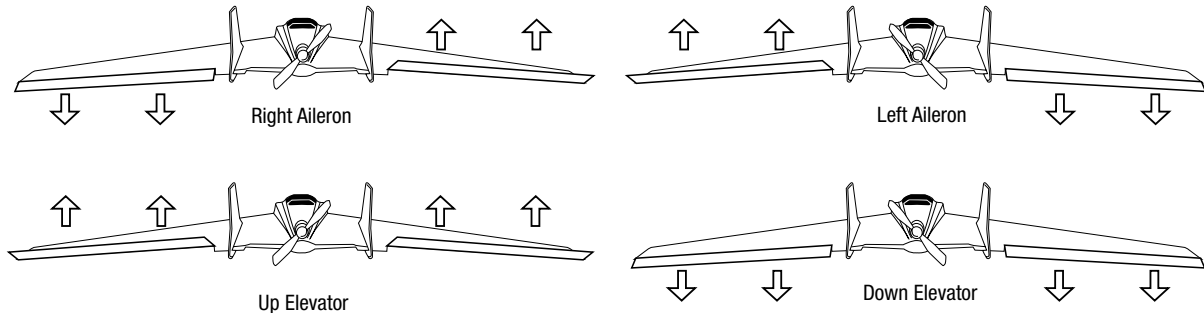

## Step 2 E-flite 25-Amp Brushless ESC

Your F-27C Stryker PNP comes out of the box with the E-flite 25A Brushless ESC. This controller has been designed for use in radio control aircraft to handle up to 25 amps of continuous motor current and up to 4 micro servos with a 2- to 3-cell Li-Po battery. It is suitable to use with most radio brands. The ESC comes in an impressive plastic case with exposed, finned heat sinks for both of the motor drive mosfets. And, unlike many ESCs, it also has a finned heat sink fitted to the BEC regulators to give a more reliable and potent power supply to the servos. If you intend to fly your F-27C Stryker PNP stock, then there is no need to program the ESC. It comes installed with the default settings for the installed motor. If you intend to re-program the ESC, we strongly recommend removing the propeller first in order to avoid the propeller from spinning if the motor is accidentally engaged.

**Note: ALWAYS assume the motor and the propeller are live. ALWAYS keep clear of the propeller at all times. The high rpm of the brushless motor can cause severe injury.**

The E-flite 25-amp ESC has the following features:

- Two soft-cut settings (for 2- and 3-cell Li-Po battery packs)
- 70% Smart Cut feature
- Brake option
- Timing options for up to a 4-pole motor and motors with more than 4-poles
- 2 setting options for the throttle input range

### Using the E-flite 25A Brushless ESC:

The E-flite 25A Brushless ESC is very simple to use. It includes a safety feature that will not arm the motor until the throttle stick has been held in the Idle/Off position for more than one second. When the battery is first connected, the ESC will indicate what setting you have selected for the soft cut voltage with a low, long beep followed by two or three medium length, mid-tone beeps to indicate the cell count (7 beeps if 70% Smart Cut is selected).

**Note:** Some computer radios may require the ATV to be increased on the low end to arm the ESC. Try using increments of 5%, such as 105%, 110%, etc.

Also make sure the servo reversing switch on the Tx is set at normal, or it will not arm.

To prepare for flight, turn on your transmitter and ensure the throttle is set to the idle/OFF position. Next, plug in the flight pack to the speed control and listen for the tones to indicate soft cut voltage. After the controller has indicated the cell count, the controller will make one set of 3 medium length, rising tones to tell you it is armed and ready to fly, or 2 sets of fast rising tones if you are entering the programming mode.

For your own safety, and the safety of others, you should always treat the motor and propeller as though they are "live" and dangerous, remembering that the motor could start at any time.

## Step 2 *continued*

Keep any body parts, clothing and tools clear of the propeller arc. **Never leave the battery connected when you are not flying the aircraft.** Always remove the battery pack from the model before charging the battery, and when finished flying.

### Programming:

The programming sequence of the E-flite 25A Brushless ESC uses an intuitive **stick up=Full Throttle** or **stick down=Idle** menu system that is designed to be very simple to learn and remember.

The default setup for your E-flite 25-amp ESC is:

- 3S auto cutoff
- Brake inactive
- 4-pole and greater timing
- Auto setting throttle input range

### To enter the programming mode:

1. With the battery disconnected from the ESC, and the transmitter turned on, first move the throttle stick to the full-power position. Leave it in this position and then connect the battery to the controller.
2. After five seconds, the ESC will give two sets of fast ringing tones to indicate you have successfully entered the programming mode.
3. Once you hear these tones, move the stick to center and the ESC will beep once, indicating that you are at menu item #1.
4. The ESC will now wait five seconds for you to make your selection. Move the stick to Full Throttle or to Idle.
5. When you have made a valid selection, the ESC will beep once with a lower tone and then you can move the stick back to center for the next menu item. It will then beep twice indicating that you are at menu item #2 (three times for menu item #3 and so on). If you do not make a selection within 5 seconds, the ESC will move to the next menu item.

### To exit programming mode at any point in the menu sequence:

1. Move the throttle stick to Idle, after making your last menu selection.
2. Simply unplug the battery – or – wait approximately eight seconds until the ESC indicates it has armed the motor with one set of three medium length, rising tones.

### Menu Item Selections:

The menu items and choices are as below;

#### Menu Item 1: Cell Count

Stick up - 3S Li-Po soft cut (default setting)

Stick down - 2 cells Ni-Cd or Ni-MH and our exclusive 70% Smart Cut. (See below for Smart Cut information).

To access the 70% Smart Cut option, leave the stick at Full Throttle for 7 seconds while in menu item 1, until 7 beeps are heard, then continue through the program normally. This option will activate the soft cut at 70% of startup voltage. For example, if your pack measures 10.0 volts at startup, then the soft cut will occur at 7 volts. The Smart Cut option will check the startup voltage every time you plug the controller in, so beware of using partially charged packs, as the system cannot protect your Li-Po batteries if you are using Smart Cut and connect a partially charged pack.

**Note:** The default setting is 3-cell auto cutoff (3.05 volts per cell). You will know that your battery pack has reached auto cutoff when you hear the motor “whine/pulse” repeatedly.

#### Menu Item 2: Brake

Stick up - Brake inactive (default setting)

Stick down - Brake active

This option gives you the choice to force the propeller to stop during flight or allow it to windmill. Use the brake option for gliders.

#### Menu Item 3: Timing

Stick up - 4-pole and greater timing mode (default setting)

Stick down - 2-pole motors

Refer to your motor specifications to confirm the number of poles.

#### Menu Item 4: Input Range

Stick up - Throttle range 1.1mS to 1.9mS

Stick down - Auto set (default setting)

This option is to allow for all the different radios on the market. Most radios will work well with the auto set option, but some radios have a wider output range and may give a more linear response with the 1.1- to 1.9mS range. If you feel that there is too much “dead” area in the stick movement near full throttle, try adjusting the end points in your radio or change to the wider input range. Beware that if

## Step 2 *continued*

these settings are not correct, it may be impossible to arm the controller. If this happens, return the input range setting to the default auto learning setting. The auto setting option learns the minimum position of your throttle (between 1.1 and 1.3mS), stores this value at each startup, and then adds a value of 0.6mS for the full throttle setting.

### **Error Codes:**

The controller will beep continuously (beep..beep..beep) if the input voltage is below the soft-cut voltage when the battery is connected. If you have trouble arming the controller, enter the programming mode and try the auto setting in menu item 4 to see if it helps fix your problem. If it is a computer radio, you may alternatively increase your ATV (endpoint) percentages.

**Note:** If you reverse the polarity of the ESC, you will destroy it. Do not allow the ESC to contract any moisture.

When flying in hot weather, we recommend checking on the condition of the ESC, battery, and motor after each flight. You should strongly consider letting the electronic components cool between flights. We also recommend throttle management. Flying an entire flight at full throttle can cause permanent damage to your motor, battery, and ESC.

For more information regarding specifications and information on the E-flite 25A ESC, go to [e-fliterc.com](http://e-fliterc.com)

## Step 3 **ParkZone 6-Pole 1880Kv Brushless Motor**

Your F-27C Stryker PNP is powered by ParkZone's 6-pole 1880Kv brushless motor, which is installed at the factory, and a 6 x 4 propeller. The 6 x 4 propeller, along with the motor, was chosen to create the correct balance of speed and torque and we do not recommend changing propeller sizes.

### **Warning:**

Changing the propeller size could increase the current draw and may cause damage to the motor, ESC and battery pack.

## Step 4 **Charging Your Li-Po Battery**

The ParkZone team recommends that you fly your F-27C Stryker PNP with a 3S Li-Po battery pack. The one that comes stock with the ready-to-fly version of the F-27C is a 3S 11.1V 2200mAh pack, which features a balancing charge lead to more safely charge the pack (PKZ1030). In order to avoid damage and possibly a fire, you must charge your Li-Po pack with a Li-Po compatible charger and at the proper charge rate. The ParkZone Li-Po charger that comes with the F-27C Stryker PNP ready-to-fly will work well with the ParkZone Li-Po battery pack (PKZ1040).

Refer to the chart below to select the appropriate charge rates:

Capacity:	Charge Rate:
300mAh–400mAh	300mAh
500mAh–1000mAh	500mAh
1000mAh–1500mAh	1A
1500mAh–2000mAh	1.5A
2000mAh or greater	2.0A

**Warning: Selecting a charge rate higher than 1 x battery capacity may cause a fire!**

## Step 5 Checking the Center of Gravity

The correct center of gravity (CG) sits approximately 6 inches (15.25cm) in front of the trailing edge of the elevons and is based on using the ParkZone 3S 2200mAh Li-Po battery (PKZ1030). Molded round holes in each side of the finger holds on the bottom of the plane mark the correct CG location.

Whatever 3S Li-Po battery you choose, the CG should be correct, provided you insert it correctly into the molded bat-

tery saddle. In order to avoid any problems, always double-check the CG when using a different size battery from the one you previously used. Also, any battery you choose should fit snugly into the foam saddle to prevent the CG from shifting in flight.

## Step 6 Range Checking Your Radio System

Prior to each flight, range check the radio system to make certain everything is functioning correctly. To do this:

- Make certain that no one is using the channel you will be flying on.
- Always make sure the transmitter is on prior to plugging in the flight battery, and when you have finished flying, the transmitter is turned off after the battery has been unplugged.
- Have someone help you with your range check. One person needs to carefully hold the aircraft while the other walks approximately 100 feet (30 meters) away. **Make certain the person holding the plane stays clear of the propeller.**
- With the radio on and the battery plugged in, the person with the transmitter needs to turn the motor on and off, and move the elevons up and down, to ensure the plane functions properly and is receiving a strong signal from the transmitter. Make certain the aircraft is responding correctly to all input. If the aircraft does not respond properly to every control command, **DO NOT FLY**. Call the Horizon Hobby Product Support Team at: 1-877-504-0233 (M – F, 8 a.m. to 7 p.m. CST).
- Prior to each flight, always make sure all controls are functioning per the transmitter input.
- Always make sure you have fully charged transmitter batteries.

## Step 7 Launching and Landing

As stated in the beginning of this instruction manual, we recommend you only fly the F-27C Stryker PNP at an AMA sanctioned flying field. This airplane covers ground at more than 80 mph (129 kilometers/hour) – that's 117.3 feet per second or 35.8 meters per second. Make certain no one is flying on the same frequency before you take flight.

1. Always launch your aircraft directly into the wind, with a very slight upward angle.
2. We recommend launching with power off, and then adding between 60% and full throttle. This is due to the fact that the F-27C Stryker PNP has a pusher propeller, and if you are not careful you could cut your finger(s).
3. Do not fly the F-27C Stryker PNP at full throttle for the duration of your flight. This may cause permanent damage to your Li-Po battery and/or ESC.
4. After several minutes of flying, (approximately 6-10) and when you begin to feel the power decreasing, it is time to land.
5. Line up the aircraft directly into the wind when landing, making sure you land with no power to the motor. This will avoid causing damage to the prop, motor, and other components of the plane.



# F-27C Stryker Plug-N-Play™ Parts

## Replacement Parts:

Item	Description	Retail
PKZ1009	Propeller: F-27C (6 x 4)	\$ 2.99
PKZ1010	Prop Adapter	\$ 4.99
PKZ1061	Mini Servo (3) with Arms, Long Lead	\$ 12.99
PKZ1062	Servo Gear Set (3W and 5W)	\$ 2.49
PKZ1212	Battery Hatch	\$ 3.49
PKZ1218	Clevis and Pushrod	\$ 2.49
PKZ1220	Vertical Fin Set	\$ 7.99
PKZ1221	Vertical Fin Retainer (2)	\$ 1.59
PKZ4203	Decal Sheet	\$ 5.99
PKZ4213	Complete Hatch Set	\$ 7.99
PKZ4215	Painted Nose	\$ 4.99
PKZ4216	6-pole 1880Kv Brushless Motor	\$ 55.99
PKZ4233	Elevons with Control Horns	\$ 3.99
PKZ4234	Motor Mount with Hardware	\$ 4.99
PKZ4276	Instruction Manual	\$ .99
EFLA1025	25A Brushless ESC	\$ 52.99

## Optional Accessories:

Item	Description	Retail
PKZ1030	3S 2200mAh Li-Po Battery	\$ 75.99
PKZ1040	Variable Rate DC Balancing Charger	\$ 34.99
PKZ1050	3S 2200mAh Li-Po and 2-3S DC Balancing Li-Po Charger	\$119.99
PKZ1051	Non-Balancing Charge Lead Adapter (3S to EC3)	\$ 2.99
PKZ1052	Non-Balancing Charge Lead Adapter (3S to JST)	\$ 1.99
PKZ1053	Non-Balancing Charge Lead Adapter (2S to JST)	\$ 1.99
PKZ1267	Unpainted Fuselage	\$ 19.99
PKZ4141	Transmitter: (T572) CH 17, 72.130	\$ 32.99
PKZ4142	Transmitter: (T572) CH 19, 72.170	\$ 32.99
PKZ4143	Transmitter: (T572) CH 21, 72.210	\$ 32.99
PKZ4144	Transmitter: (T572) CH 50, 72.790	\$ 32.99
PKZ4145	Transmitter: (T572) CH 52, 72.830	\$ 32.99
PKZ4146	Transmitter: (T572) CH 54, 72.870	\$ 32.99
PKZ4151	Receiver: (RG600T) CH 17, 72.130	\$ 28.99
PKZ4152	Receiver: (RG600T) CH 19, 72.170	\$ 28.99
PKZ4153	Receiver: (RG600T) CH 21, 72.210	\$ 28.99
PKZ4154	Receiver: (RG600T) CH 50, 72.790	\$ 28.99
PKZ4155	Receiver: (RG600T) CH 52, 72.830	\$ 28.99
PKZ4156	Receiver: (RG600T) CH 54, 72.870	\$ 28.99
PKZ4161	FM Crystal Set: Ch 17, 72.130	\$ 9.99
PKZ4162	FM Crystal Set: Ch 19, 72.170	\$ 9.99
PKZ4163	FM Crystal Set: Ch 21, 72.210	\$ 9.99
PKZ4164	FM Crystal Set: Ch 50, 72.790	\$ 9.99
PKZ4165	FM Crystal Set: Ch 52, 72.830	\$ 9.99
PKZ4166	FM Crystal Set: Ch 54, 72.870	\$ 9.99

## Future RC Flight

Thank you for choosing to purchase the F-27C Stryker PNP. We are sure you will have an amazing time flying it, and hope that you will consider checking out ParkZone's many other fun and exciting aircraft at [www.ParkZone.com](http://www.ParkZone.com). Please don't hesitate to give us a call if you have any questions. Our Product Support Team is available to help you enjoy your flying experience. They can be reached toll-free, Monday through Friday 8 a.m. to 7 p.m. CST, at 1-877-504-0233.

Sincerely,  
The ParkZone Team

# Warranty

---

## Limited Warranty Period

Horizon Hobby, Inc. guarantees this product to be free from defects in both material and workmanship at the date of purchase.

## Limited Warranty & Limits of Liability

Pursuant to this Limited Warranty, Horizon Hobby, Inc. will, at its option, (i) repair or (ii) replace, any product determined by Horizon Hobby, Inc. to be defective. In the event of a defect, these are your exclusive remedies.

This warranty does not cover cosmetic damage or damage due to acts of God, accident, misuse, abuse, negligence, commercial use, or modification of or to any part of the product. This warranty does not cover damage due to improper installation, operation, maintenance, or attempted repair by anyone other than an authorized Horizon Hobby, Inc. service center. This warranty is limited to the original purchaser and is not transferable. In no case shall Horizon Hobby's liability exceed the original cost of the purchased product and will not cover consequential, incidental or collateral damage. Horizon Hobby, Inc. reserves the right to inspect any and all equipment involved in a warranty claim. Repair or replacement decisions are at the sole discretion of Horizon Hobby, Inc. Further, Horizon Hobby, Inc. reserves the right to change or modify this warranty without notice.

REPAIR OR REPLACEMENT AS PROVIDED UNDER THIS WARRANTY IS THE EXCLUSIVE REMEDY OF THE CONSUMER. HORIZON HOBBY, INC. SHALL NOT BE LIABLE FOR ANY INCIDENTAL OR CONSEQUENTIAL DAMAGES.

As Horizon Hobby, Inc. has no control over use, setup, final assembly, modification or misuse, no liability shall be assumed nor accepted for any resulting damage or injury. By the act of use, setup or assembly, the user accepts all resulting liability.

If you as the purchaser or user are not prepared to accept the liability associated with the use of this product, you are advised to immediately return this product, in new and unused condition, to the place of purchase.

## Safety Precautions

This is a sophisticated hobby product and not a toy. It must be operated with caution and common sense and requires some basic mechanical ability. Failure to operate this product in a safe and responsible manner could result in injury or damage to the product or other property. This product is not intended for use by children without direct adult supervision.

The product manual contains instructions for safety, operation and maintenance. It is essential to read and follow all the instructions and warnings in the manual, prior to assembly, setup or use, in order to operate correctly and avoid damage or injury.

## Questions, Assistance, and Repairs

Your local hobby store and/or place of purchase cannot provide

warranty support or repair. Once assembly, setup or use of the product has been started, you must contact Horizon Hobby, Inc. directly. This will enable Horizon to better answer your questions and service you in the event that you may need any assistance.

## Questions or Assistance

For questions or assistance, please direct your email to [product-support@horizonhobby.com](mailto:product-support@horizonhobby.com), or call toll free 877.504.0233 (M – F, 8 a.m. – 7 p.m. CST) to speak to a service technician.

## Inspection or Repairs

If your product needs to be inspected or repaired, please call for a Return Merchandise Authorization (RMA). Pack the product securely using a shipping carton. Please note that original boxes may be included, but are not designed to withstand the rigors of shipping without additional protection. Ship via a carrier that provides tracking and insurance for lost or damaged parcels, as Horizon Hobby, Inc. is not responsible for merchandise until it arrives and is accepted at our facility. Include your complete name, address, phone number where you can be reached during business days, RMA number, and a brief summary of the problem. Be sure your name, address, and RMA number are clearly written on the shipping carton.

## Warranty Inspection and Repairs

To receive warranty service, you must include your original sales receipt verifying the proof-of-purchase date. Providing warranty conditions have been met, your product will be repaired or replaced free of charge. Repair or replacement decisions are at the sole discretion of Horizon Hobby.

## Non-Warranty Repairs

Should your repair not be covered by warranty and the expense exceeds 50% of the retail purchase cost, you will be provided with an estimate advising you of your options. You will be billed for any return freight for non-warranty repairs. Please advise us of your preferred method of payment. Horizon Hobby accepts money orders and cashiers checks, as well as Visa, MasterCard, American Express, and Discover cards. If you choose to pay by credit card, please include your credit card number and expiration date. Any repair left unpaid or unclaimed after 90 days will be considered abandoned and will be disposed of accordingly.

Electronics and engines requiring inspection or repair should be shipped to the following address (freight prepaid):

**Horizon Service Center**  
**4105 Fieldstone Road**  
**Champaign, Illinois 61822**

All other products requiring inspection or repair should be shipped to the following address (freight prepaid):

**Horizon Product Support**  
**4105 Fieldstone Road**  
**Champaign, Illinois 61822**



