

# User Guide

rev. 2018/09



Fully 3d printable

## F-86A Sabre electro ducted fan airplane

scale ~1:7,3, wingspan 1427mm (55.7 inch)

## F-86A Sabre – fully printable R/C plane for your desktop 3Dprinter

Future of flying - Print your own plane. [Speedy guide](#)

We're still trying to move things further, so this project is again full of improvements for better durability, easier assembly, better geometry solution and more..., we hope you enjoy it, although this print may test your abilities and quality of your printer...

Welcome to the thin wall printing!

**The first fully printable** airplanes with files prepared for your 3Dprinter, with flight characteristics, comparable or even superior to classic build model airplane. This is not a dream, now you can print this HI-TECH at home. Simply download and print the whole plane or spare parts anytime you need just for a cost of filament only about \$40

**Extensive hi-tech 3d structural reinforcement** making the model very rigid while maintaining a lightweight airframe and exact airfoil even it's just a plastic. This perfect and exact 3d structure is possible only thanks to additive 3dprinting technology. So welcome to the 21st century of model flying and be the first at your airfield.

**Easy to assemble**, you don't need any extra tools or hardware, simply glue the printed parts together and make pushrods for controls. The rest of the assembly is very easy. Simply add brushless EDF, ESC, servos and radio system. Detailed step by step PDF/VIDEO userguide is included.

We designed this aircraft the way you don't need any nuts or additional joining elements, just click all printed parts together.

You will get a great performing training and durable airplane able to withstand even hard landings (easily changeable landing gear). Our F-86A Sabre is a spin-stall proof plane even in low speed tight turn.

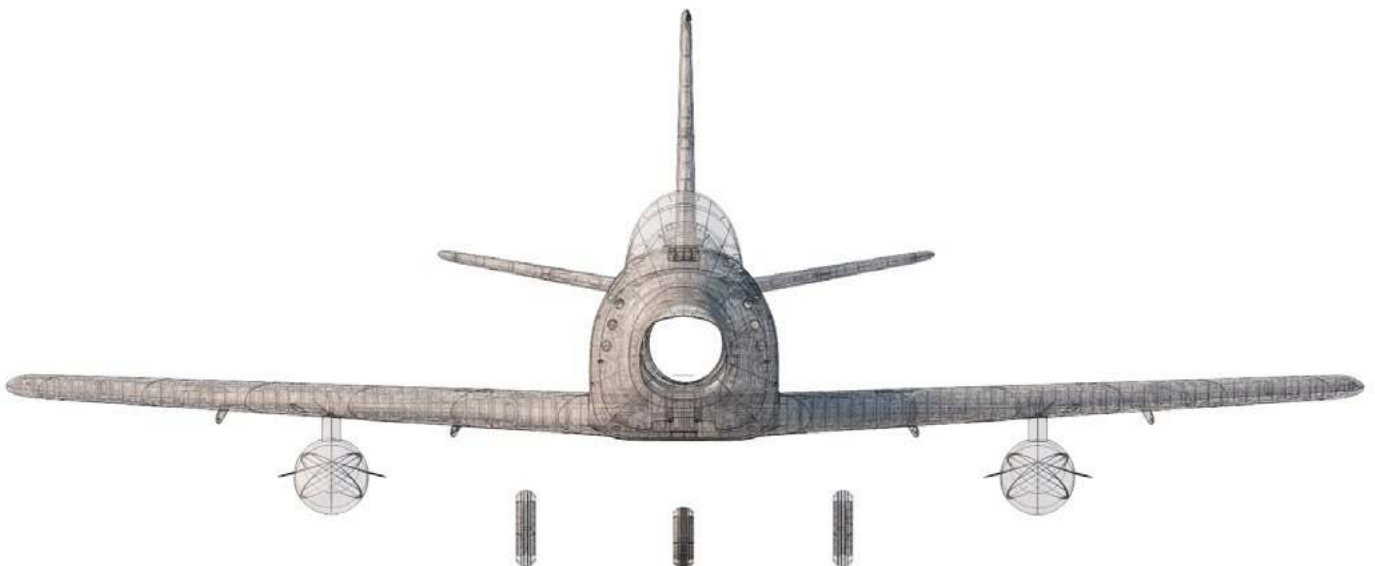

## General specifications:

Length:	1427mm / 55.7 inch
Wingspan:	1427mm / 55.7 inch
Height:	560 mm / 21.8 inch
Wing area:	45,76 dm <sup>2</sup> / 4.92 sq foot
Wing loading:	104 g/dm <sup>2</sup> / 28 oz at sq foot
Center of gravity:	248mm (9.68 inch) from LE See CG tags on wings...
Airfoil:	3DLabPrint modified
Print weight:	2485 g / 87.6 oz
Empty weight (w/o battery):	3900 g / 137.5 oz
Takeoff weight (2x 3s 3700 lipo):	4760 g / 167.9 oz
Max takeoff weight:	5500 g / 194.0 oz
Never exceed speed, VNE:	200 km/h / 125 mph
Design maneuvering speed, VA:	120 km/h / 75 mph
Stall speed:	50 km/h / 15 mph



## Powerplant

EDF:	90mm for 6S (or 8S) Li-Pol
Motor:	1750kV
ESC:	<a href="#">100A Electronic Speed Controller</a> or similar 80-100Amps
Battery:	2x <a href="#">Li-Pol 6200mAh/3s (40-65C)</a> , at least 451g / 17.9oz, 65C (fuselage space for 3000-6200mAh packs)



## Performance measurement

Max speed VH (level flight):	150 km/h 80 kn 90 mph with 6s Li-Pol
Rate of climb:	46 m/s (10 673 ft/min)
Flight time (2x 3s 6200mAh):	11:00min

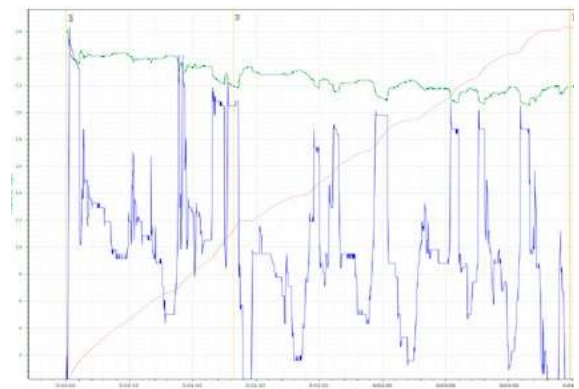



## F-86A Sabre, History

The North American F-86 Sabre, is a transonic jet fighter aircraft. Produced by North American Aviation, the Sabre is best known as the United States' first swept wing fighter that could counter the swept-wing Soviet MiG-15 in high-speed dogfights in the skies of the Korean War (1950–1953), fighting some of the earliest jet-to-jet battles in history. Considered one of the best and most important fighter aircraft in that war, the F-86 is also rated highly in comparison with fighters of other eras. Although it was developed in the late 1940s and was outdated by the end of the 1950s, the Sabre proved versatile and adaptable and continued as a front-line fighter in numerous air forces.

Its success led to an extended production run of more than 7,800 aircraft between 1949 and 1956, in the United States, Japan, and Italy. Variants were built in Canada and Australia. The Sabre is by far the most-produced Western jet fighter, with total production of all variants at 9,860 units.



## Included:

### 1. STL 3d files

Universal STL files designed for use with desktop FMD 3d printers and slicer software such as Simplify3D (recommended) CURA or MatterControl (these STLs are not compatible with Slic3r or Makerware slicers).

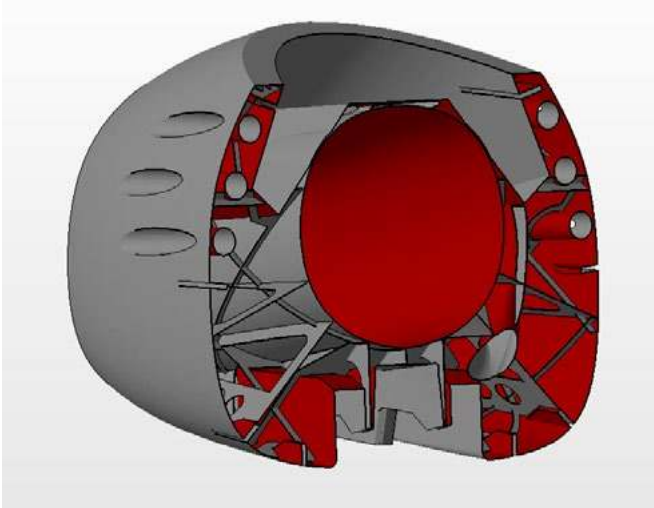

### 2. Factory files for Simplify3D slicer

with all our settings, these Factory files include all you need. Note: we're using PRUSA i3 ORIGINAL printers so you may need to adjust the basic printing parameters to match your printer or use it as a starting point for you. Please check the [Simplify3D](#)

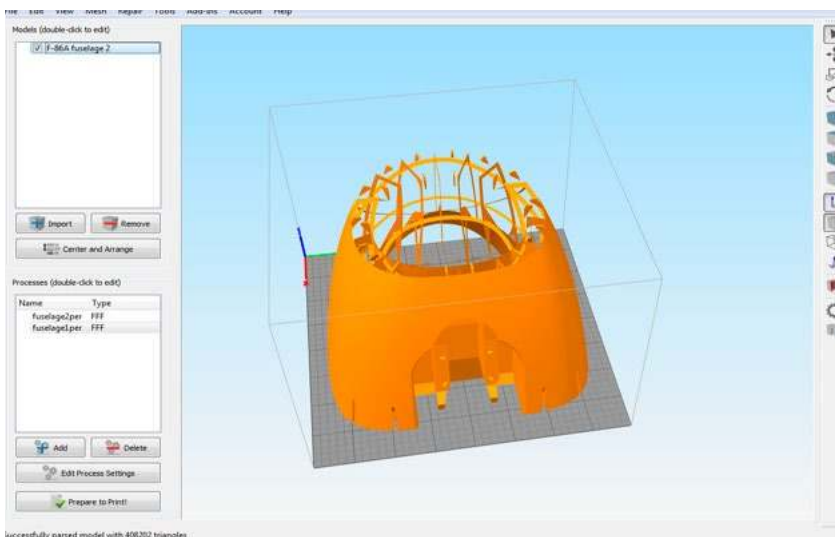

### 3. Step By Step PDF/VIDEO userguides

Apart from this userguide, please read / watch the Printing Guide with some Tips and Advice for airplane printing (Thin Wall Printing) and the Help section of the website.

## 4. Gcodes

Basic Gcodes prepared for direct use, as universal as possible. Should work with i3 style printers. We cannot guarantee that it will work with your printer, but they're 100% compatible with PRUSA i3 ORIGINAL 3d printers.

## 5. Prepared settings for CURA and MatterControl slicers

If you don't like Simplify3D for any reason, there is the possibility to use another free slicer. Please check the Help section or the latest Cura settings.

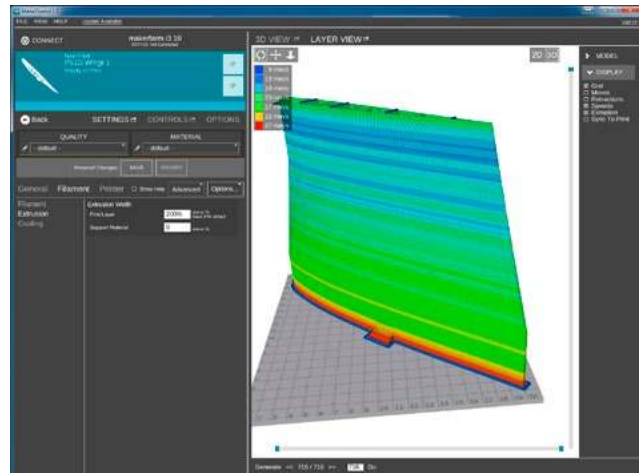
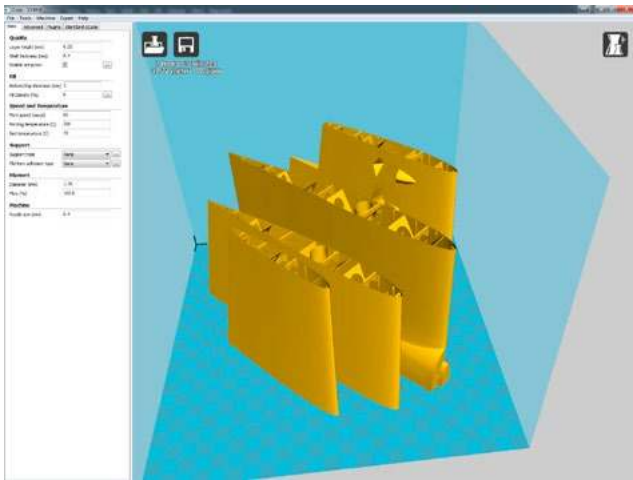

## 6. Scale markings PDF

Print this scale PDF on a thin self adhesive advertisement foil and place it on the model as required. Violet cut lines included.

U.S. AIR FORCE  
**8178**  
U.S. AIR FORCE  
**8178**

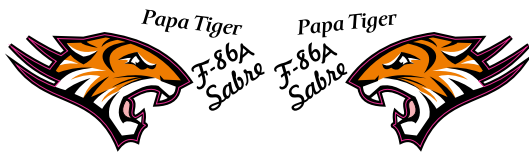

PILOT AIR MARSHAL CLIFF SPER  
★★★  
PILOT AIR MARSHAL CLIFF SPER  
★★★

**FU-178**  
**FU-178**



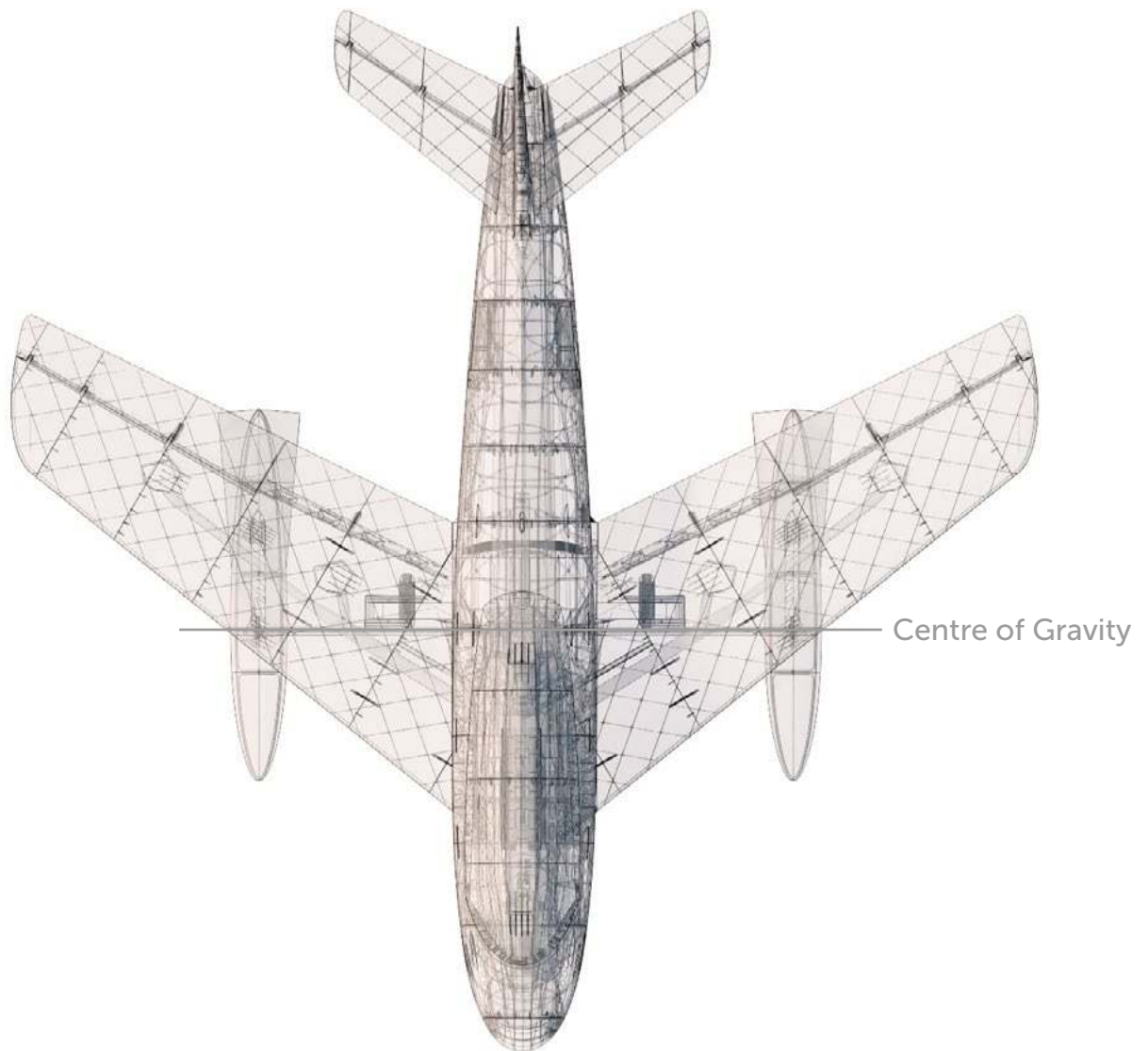

Wing area: 45,76 dm<sup>2</sup> / 4.92 sq foot

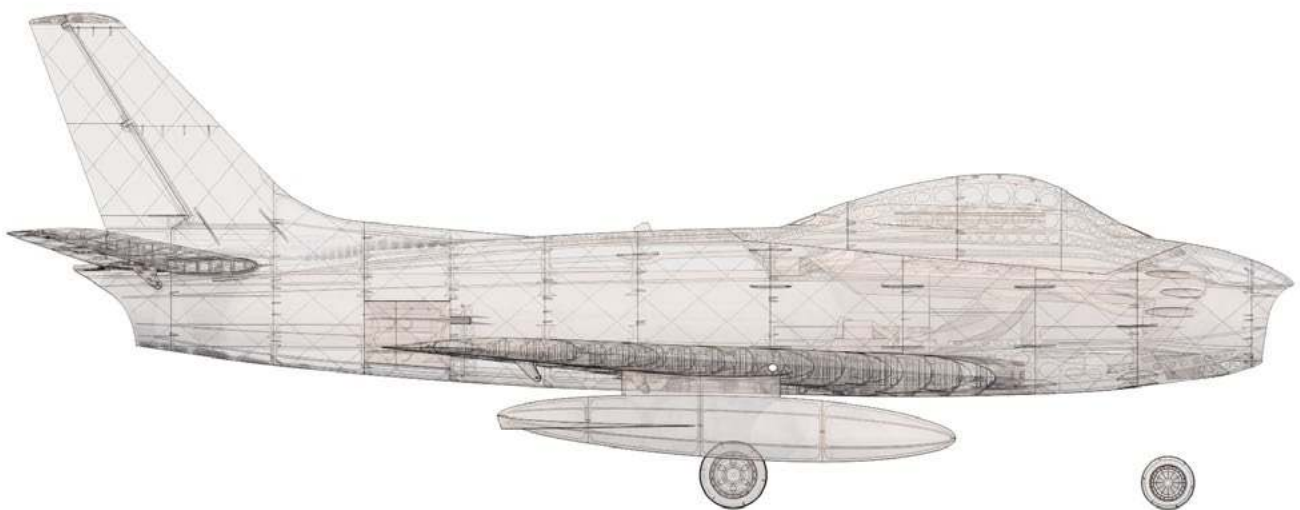

Length: 1427mm / 55.7 inch

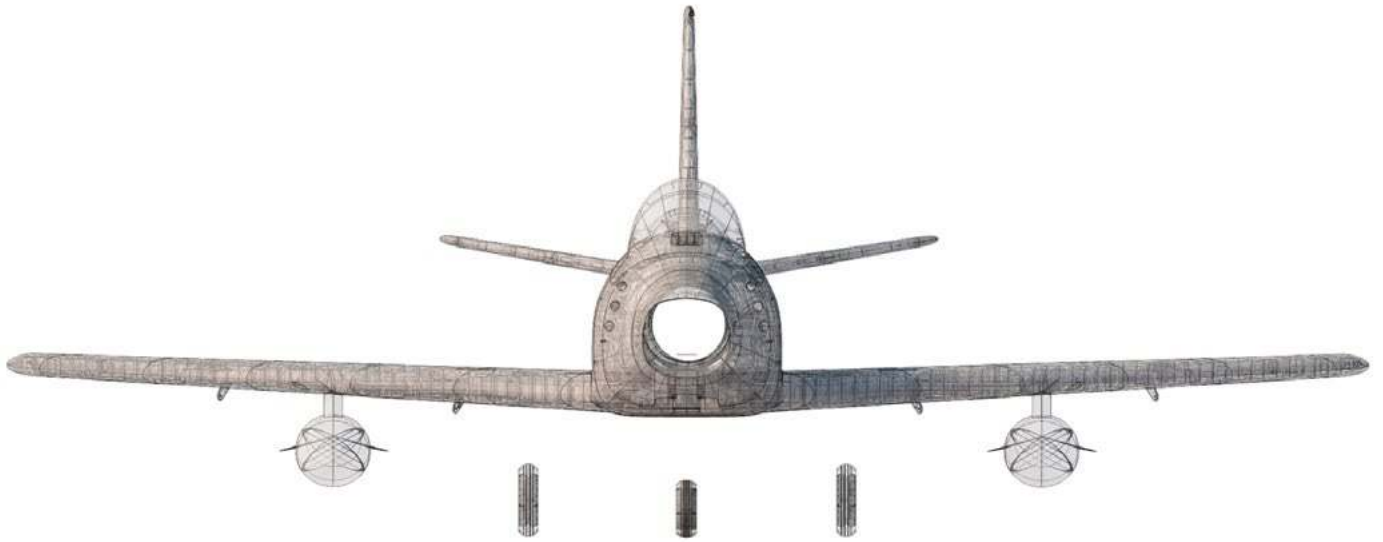

Wing span: 1427mm / 55.7 inch

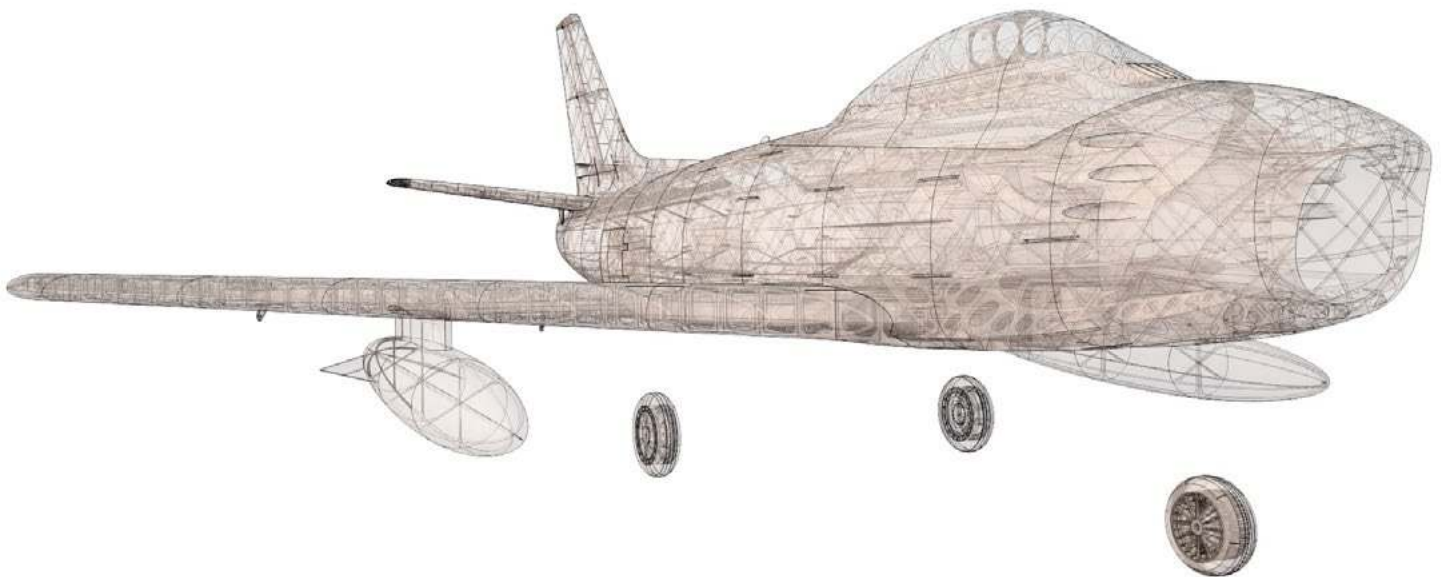



## Step By Step PDF/VIDEO userguide

### 1. Choose airplane at [www.3DLabprint.com](http://www.3DLabprint.com). Our [Facebook](#) for live information.



**Basic requirements for F-86A Sabre is 200/200/175mm build volume.** recommended nozzle size 0.4mm (alternatively 0.35 - 0.5mm), heated bed is very recommended.

PLA filament (or PETG, APLA, htPLA, PC-max.... not ABS) and some flex for tires...

If unsure you meet the requirements, you can download and try to print test part from our [FORUM](#) (usually the biggest part)

### 2. Create account, download

You'll receive the download link for all files via e-mail automatically right after the payment has been completed or you can log in to your account and download directly from our website. If you don't receive the download link within few seconds after the payment has been confirmed, please contact us on [support@3dlabprint.com](mailto:support@3dlabprint.com).

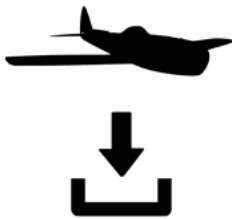

### 3. Gcodes preparing

option A Gcodes:

You can use the [precompiled gcodes](#) if your printer is compatible with Prusa i3. Simply save each file to SD card and let 3d printer do it's job. For best layer adhesion is the HE temperature set to 230°C. You can edit speed and temperature through your printer LCD or add a custom start script to the beginning of the Gcode if needed. Please proceed with the other options if the precompiled gcodes doesn't work for you.

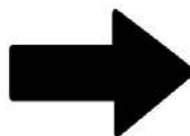
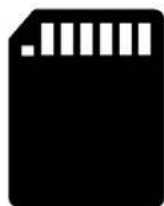

### option B Factory files Simplify3D (recommended)

We prepared all you need in these files (basic FFF profiles, parts layout, and so on...) You can use our settings as a starting point and edit according to your printer needs, print only the spare parts, etc... It should work as it is for most printers, but please go through the settings and edit it as needed. We are not liable for any damage resulting from the use of our settings. If for any reason this does not work for you, please proceed to the next option.

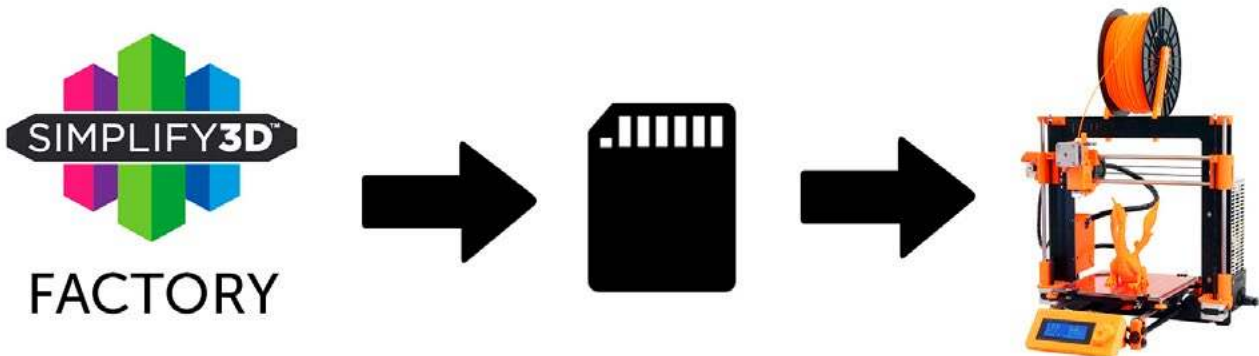

### option C Simplify3D manual setting (watch and learn)

Use our [Guide](#) to build your own factory file. This is a very good option to learn a lot about Simplify3D and become a 3D expert. Of course you spend a lot of time and the YouTube pause button will become your best friend. For simplification we show only our basic setting (wings and fuselage), please use our prepared Factory files as a reference for the rest of parts, like motor mounts, control surfaces, etc.

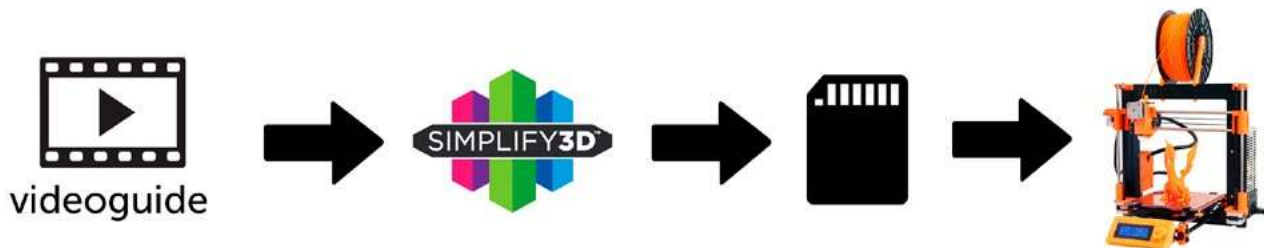

AND... please look at VideoGuides:

#### [video 2 Simplify3D setting](#)

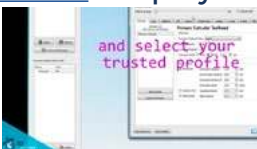

#### [video about Thin Wall Printing](#)

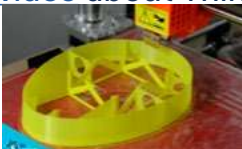

option D CURA or MatterControl (considered as the last resort, we recommend Simplify3D) MatterControl and CURA are free and provide good results. The airframe is still strong enough, but don't expect the best quality. Both slicers lacks some very useful features, and finer settings, like multiple processes according to Z height, retraction options, layer start, etc. Please try to find the best extrusion multiplier and temperature for good weight and best possible layer bonding. Look at parts weight list for proper multiplier settings.

You can also use our predefined CURA or MC (works only with older versions see info in videoguide) slicer setting file included in the package (always adapt it for your printer, change build volume, filament diameter and so on... depends on your printer!!!):

<a href="#">CURA_wing_fuse.ini</a>	(wing and fuselage (expect1) parts) + <a href="#">CURA_wing_tip.ini</a>
<a href="#">CURA_ailer_elev.ini</a>	(only ailerons, elevator and rudder parts)
<a href="#">CURA_thick.ini</a>	(fuselage1 only, struts, holders, landing gear... )
OR	
<a href="#">MC_wing_fuse.slice</a>	(wing and fuselage (expect1) parts) + <a href="#">MC_wing_tip.slice</a>
<a href="#">MC_ailer_elev.slice</a>	(only ailerons, elevator and rudder parts)
<a href="#">MC_thick.slice</a>	(fuselage1 only, struts, holders, landing gear... )

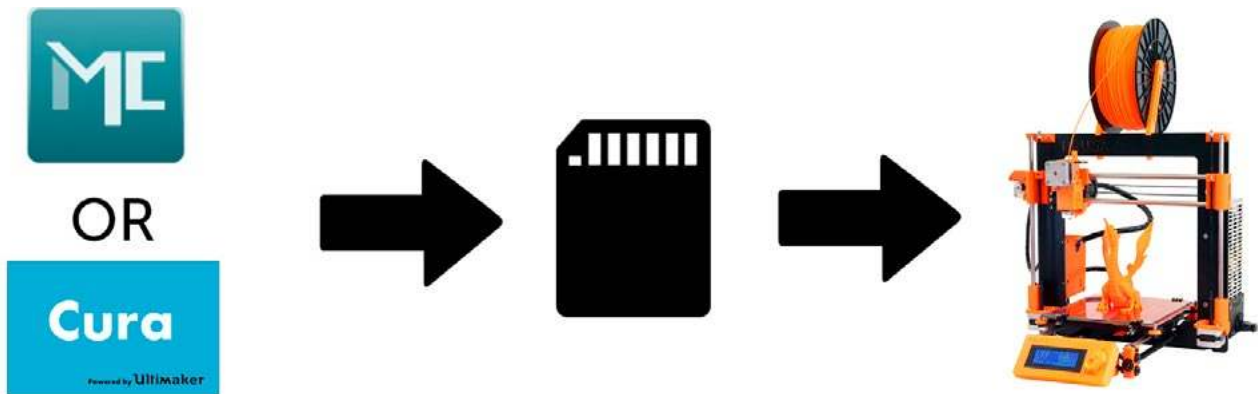

AND... please look at [VideoGuides](#) or [Help](#) for up to date info:

[Cura not slicing internal structure](#)

[CNC kitchen \(Cura setting\)](#)

[video CURA slicer setting](#)

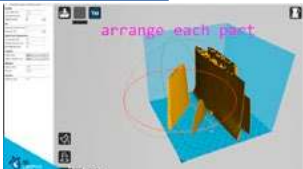

[CURA 2.3.1 import setting](#)



[video CMatterControl slicer setting](#)

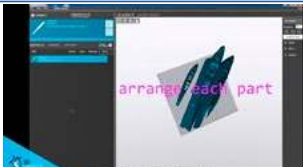

## 4. Print it

Save generated Gcodes and insert SD card to your printer, prepare your printer and start printing. We prefer to use SD rather than a direct connection via USB. Note: ABS filament is not suitable for this. Scaling the model will lead to unusable result!

Note: ninja flex or similar fillaments can stick very hard to PEI based surfaces, be careful...

Video guide [about printing](#):

You will need: PLA filament - good quality and strong PLA (we need good layer bonding)  
Strong hair spray (or your favorite adhesive bed surface)  
Razor blade  
(disregard with PEI or simmilar bed surface, Mk2...)

AND... please watch the VideoGuides:

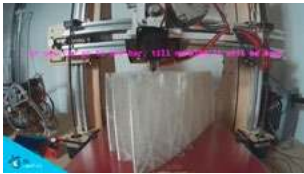

[video printing guide](#)

## F-86A Sabre - parts diagram:

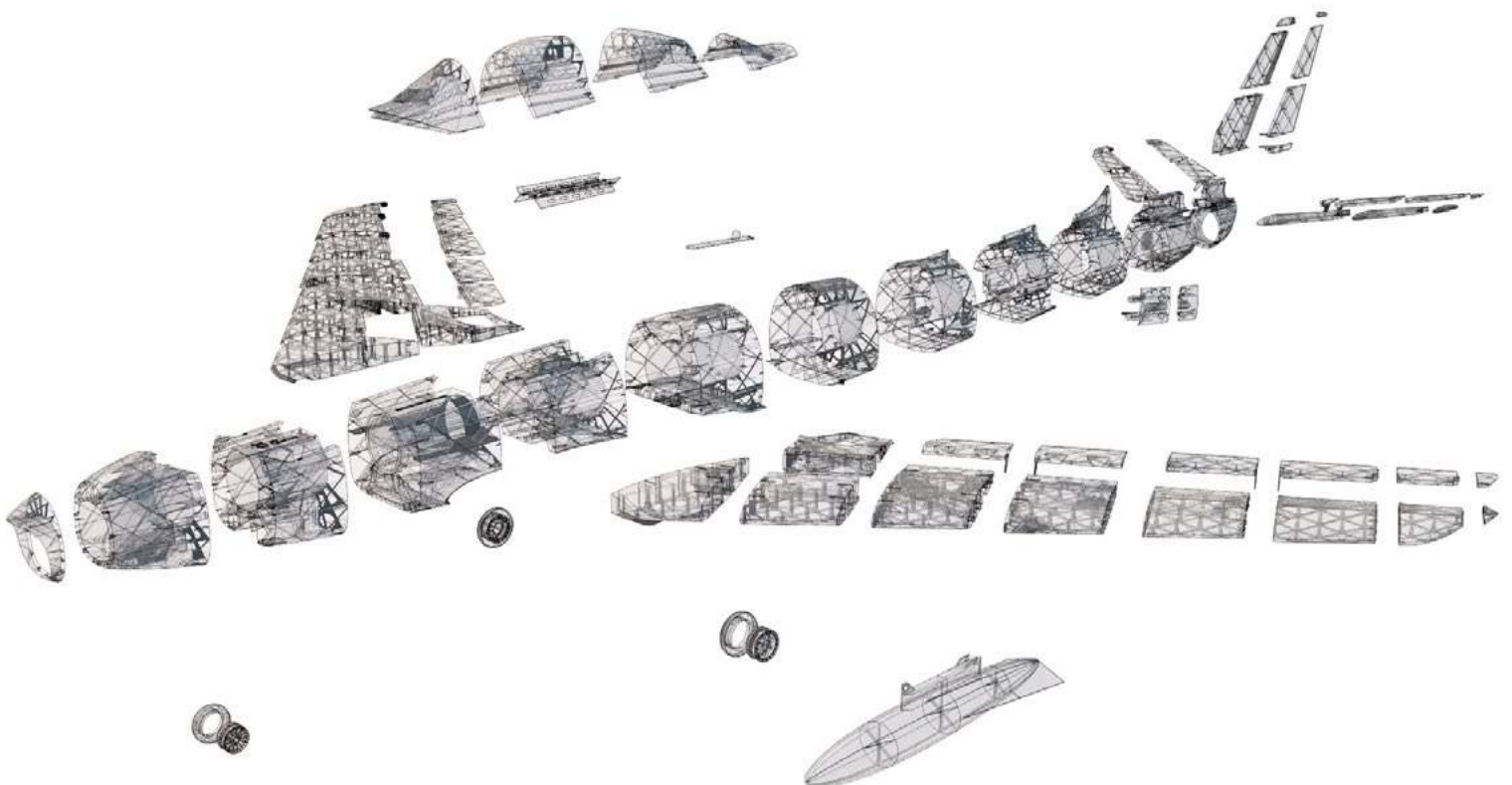

## Basic Tips and Advice

Please experiment with your extrusion multiplier to achieve the same weights as in the list. HotEnd temperature is very important for a strong result. The reason is the plastic leaving the nozzle has to melt the previous layer to create solid joint. Please try increasing the temperature

to find the best value (215° up to 260° Celsius). Turn OFF cooling fan (Heatbreak fan of course has to be left ON). Thin walls easily cools down on its own and the cooling fan worsens the layer bonding. You can use cooling fan for thick parts if needed...

Heated bed is very recommended, use 50-60° Celsius to print without warping ends.

Any standard quality PLA is suitable to print our planes, but the result depends on combination of PLA vs. Extruder vs. HotEnd.

Some colors and brands of filament has lower layer adhesion, please do experiment with it.

There are a lot of 3dprinters on the market, most of them are OK for printing our aircraft (specific thin wall printing...) with sufficient volume, heated bed, 0.4 mm nozzle.

Please see the [FAQ](#) and our [Forum](#) for more information:

Need a help? our Forum is the best place... where the community can help you

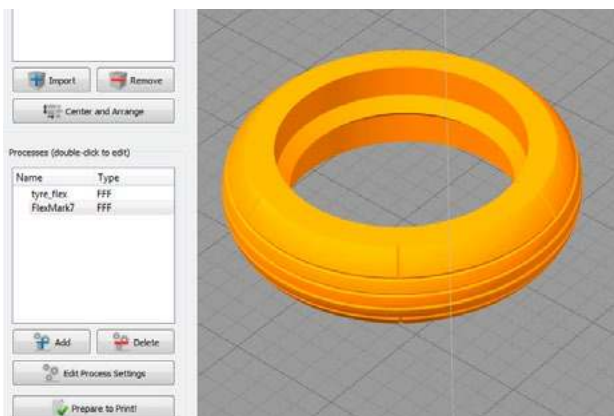
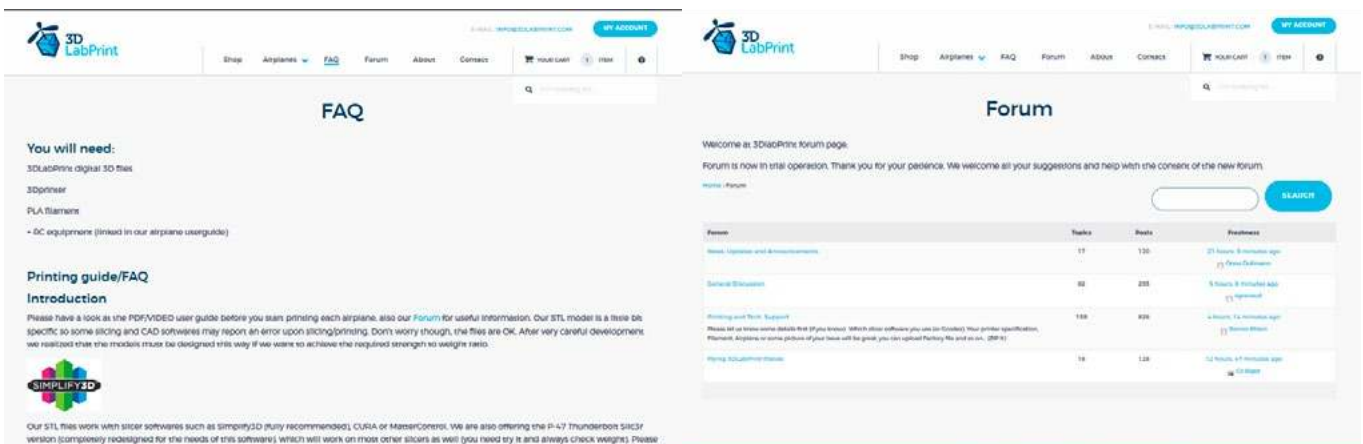

## How to print tyres?

Slowly! We have the best results with [Treed Flexmark 7](#). Perfect material for F-86A tyres but really hard to print it. Your printer has to be set for maximum printing speed of 20mm/s. You can find all the tested process settings in our factory files.

## 5. Assembling the printed parts

### 5.1 Wing assembly

For perfect alignment glue the wing parts L1 and L2 (R1 and R2) on a flat surface. Do the same with parts L3 and L4 (R3 and R4). Start glueing wing on center section, L1-L4 and R1-R4. Glue both sides with CA glue together (position locks and pins will help you), use the activator. Continue with the rest of the parts of the wing symmetrical on both sides (L5/R5 - L10/R10). You can use snap knife to clear the printed parts (mostly for the landing gear and ailerons installation), but usually this is not necessary.

Glue together all parts of flaps L1 and L2 (R1 and R2) and ailerons L1-L4 (R1-R4) and use suitable 0,8 mm carbon rod or wire as a hinge. Try if you could easily push the 8 mm wing carbon spar inside the wing slot.

[See video guide #4](#)

you will need: [CA Glue - medium or similar medium viscosity CA glue](#)  
[Activator for CA Glue](#) or similar, but gas presurized aerosol is better  
 Snap knife  
 0,8 mm carbon or steel wire

R wing completed

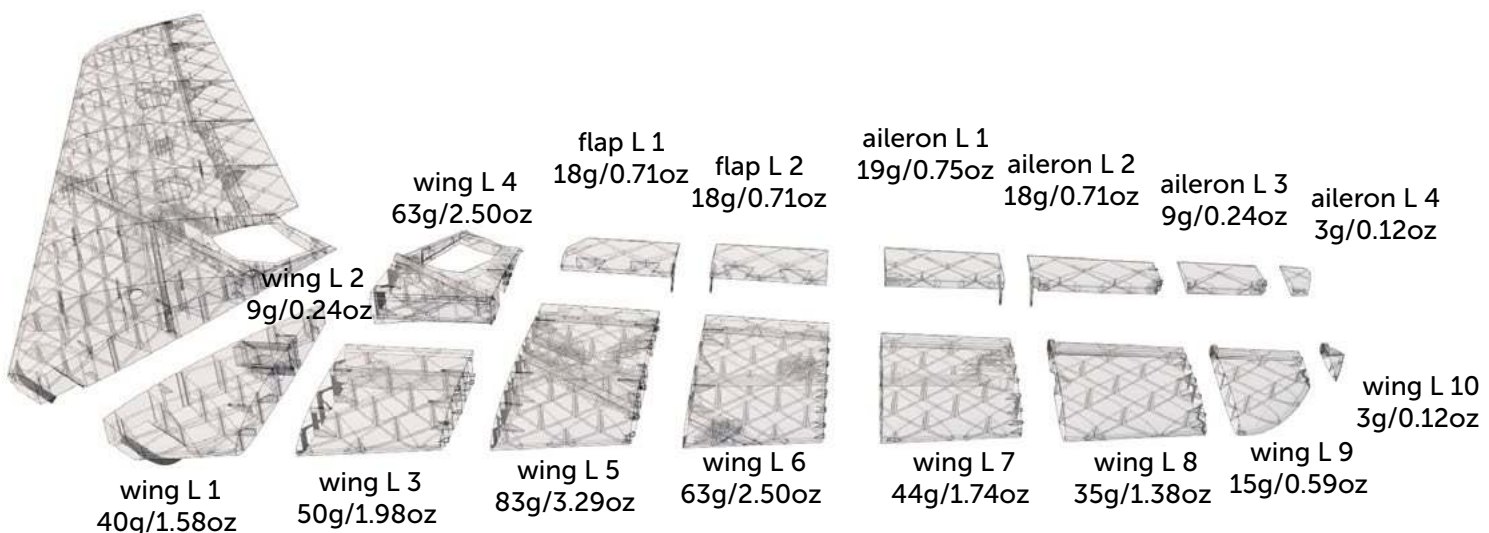

## 5.2. Fuselage assembly

Glue together the fuselage parts with CA glue (position locks and pins will help you) use the activator. You can use snap knife to clean the shape of printed parts, but mostly this is not necessary.

Glue together F1-F6 fuselage parts. Insert pen spring to F7 part, insert canopy lock, glue F7 to fuselage and test a canopy lock functionality. Glue the rest of the fuselage parts F8-F12. Glue the canopy parts 1-4 together and test the perfect fit with fuselage and canopy lock functionality.

**NOTE: Don't glue the tailparts yet !!! (for rudder, elevator and stabilizers proceed to the next step)**

[See video guide #5](#)

You will need: [CA Glue - medium or similar medium viscosity CA glue](#)  
[Activator for CA Glue](#) or similar, but gas pressurized aerosol is better  
 1x ballpoint pen spring (a spring from old ballpoint pen will work fine)  
 Snap knife  
 Soldering Iron or any hot tool

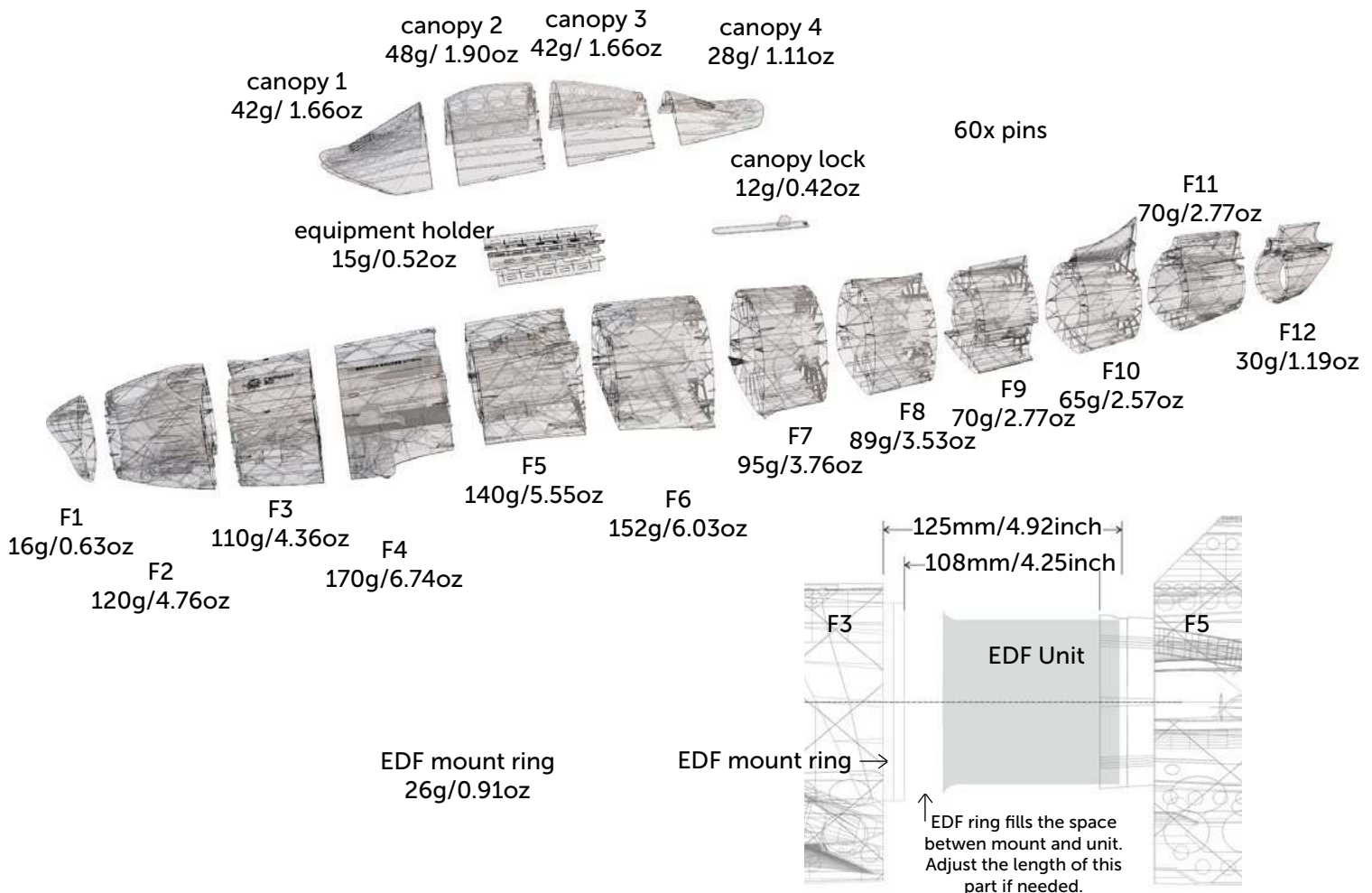

## 5.3. Fuselage tail - rudder, elevator pushrods and servos

Now it's a good time to install the tail stabilizers, elevator, rudder and pushrods. You can use snap knife to clean the shape of printed parts. Glue together the horizontal and vertical stabiliser and glue it to the fuselage. UP side of vertical stabiliser is marked. Glue the rudder and elevator. For hinge use shaped 0,8 mm / 14AWG pushrod wire or carbon rod. You can clear the holes using hot wire.

[See video guide #6](#)

You will need:

- [CA Glue - medium viscosity CA glue](#)
- [Activator for CA Glue](#) or similar, but gas presurized aerosol is better
- 0,8 mm /14AWG pushrod wire or carbon rod
- 1,2 mm / 16 AWG pushrod wires
- Wire cutter, Z bend pliers or pliers.
- Snap knife
- Soldering Iron or any hot tool

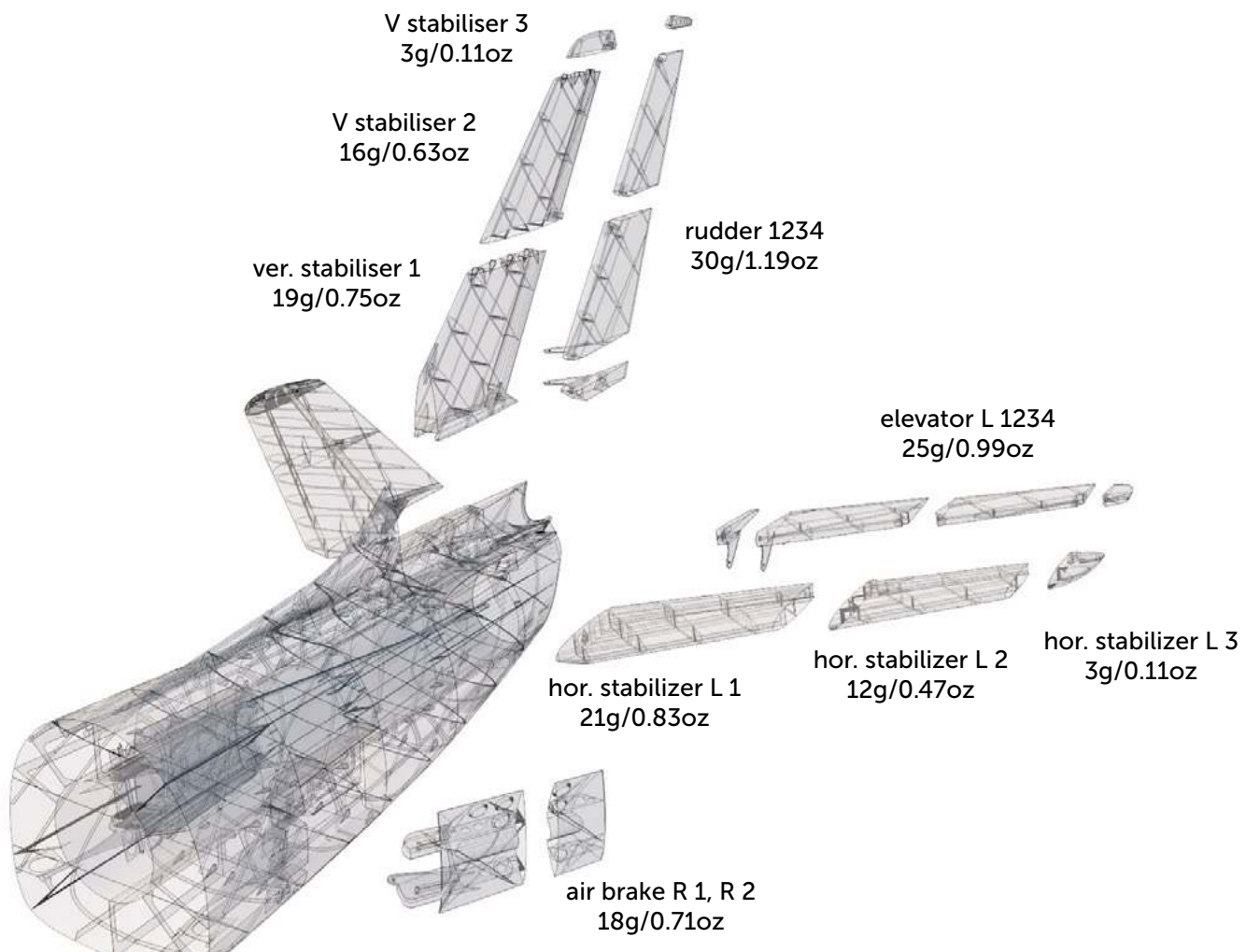



## 6.1. Servos for aileron, flaps, air brakes, rudder, elevator

Proceed with installing all the servos. Use 1,2 mm wire for pushrods. Make Z bend or use your preferred pushrods fixing method. We like these [Pushrod Keepers](#). Thread pushrods and hinge the flaps, ailerons, elevators and rudder in correct position.

[See video guide #7](#)

You will need:

9x Hitec HS-81/82MG, [Corona CS283MG](#) or similar servos  
1x Hitec HS-65 MG or [HobbyKing™ HK15178 Analog Servo](#)  
or similar for front leg  
6x [servo extension cables 300mm / 12 inch](#)  
2x [servo extension cables 500mm / 20 inch](#)  
1,2 mm / 16 AWG pushrod wires  
Wire cutter, Z bend pliers or pliers.

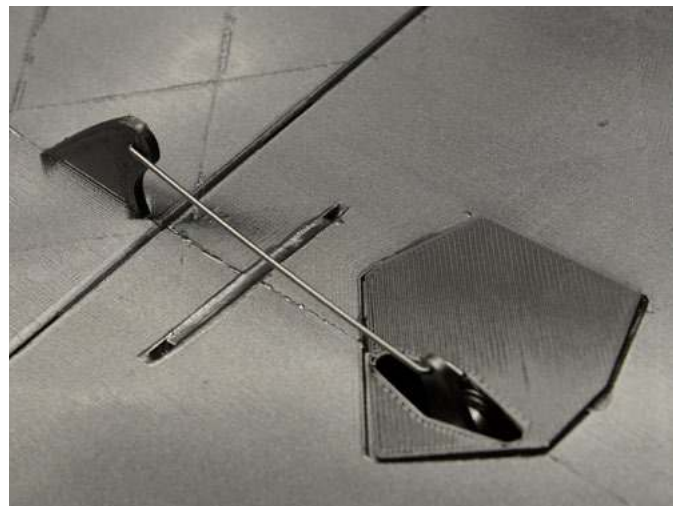

## 7.1 Landing gear - nose, main retracts

### Top Quality Retracts

The best retracts set you can buy for your F-86A Sabre are [Electron retracts ER-30eVo](#) with Electron steering system and 4mm leg pins. Great quality, perfect nose leg steering. Great retracts suitable for any plane. The best on the market.

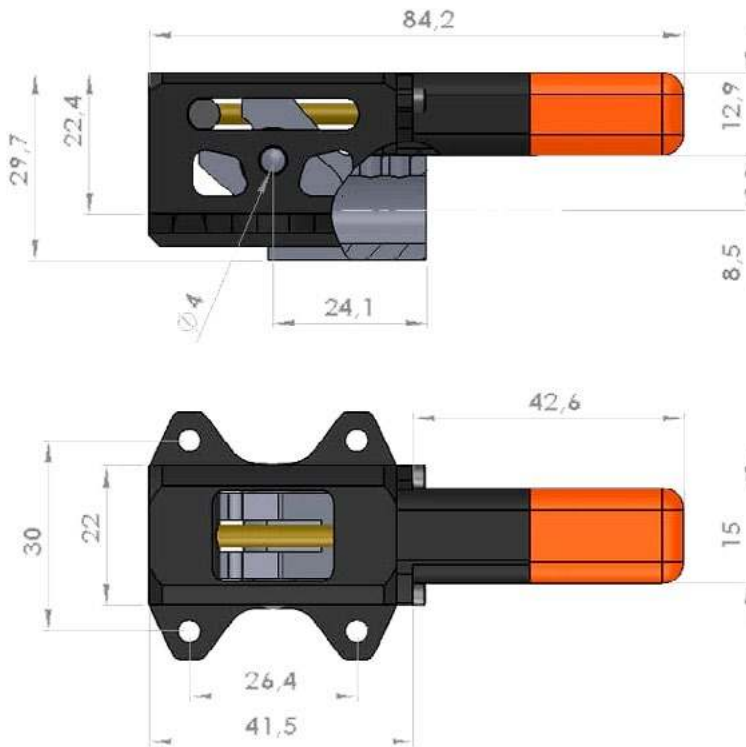

### Standard Retracts

Use standard 33mm x 35mm [Servoless Retract with 4mm metal pins](#). for main legs. For the nose leg use 33mm x 35mm [Servoless Nose Wheel Retract with 4mm metal pin](#).

**NOTE:** You can also use any other retract with similar size.



## 7.2.1 Landing gear - main legs

Suitable main landing gear legs can be found in this set [Alloy Oleo Strut Set with Wheels and Rubber Tires](#) from Hobbyking. The legs has to be slightly bent to fit into the landing gear slot. Or you can find or make any other suitable legs with the right lenght and wheel offset according the diagram below.

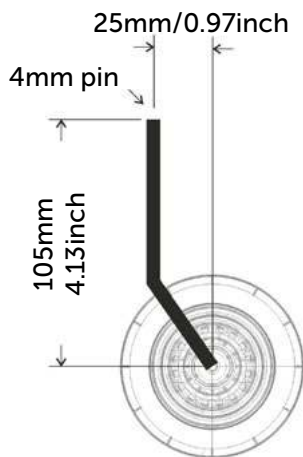

## 7.2.2 Landing gear - front leg

One of the main legs in this set [Alloy Oleo Strut set w/wheels for 90mm/1.20 Class Jet](#) is suitable as an ideal front leg, or you can again find or make any other leg with the right lenght and wheel offset according to the image below

[See video guide #8](#)

You will need: fitting screws  
1x Hitec HS-65 MG  
or [HobbyKing™ HK15178 Analog Servo](#) or similar

Electron retracts ER-30eVo  
with Electron steering system and  
alloy oleo leg 100mm / 3.90inch.

0-15mm/0-0.58inch

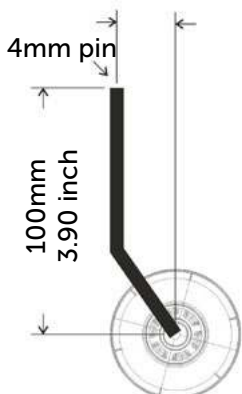

Standard Hobbyking retract with  
alloy oleo leg 100mm / 3.90inch.



## 8.1 Electro Ducted Fan propulsion system

Our F-86A Sabre was designed for 90mm EDF. We tested it with 6S and 8S Li-Pol and 3-4kg thrust. The use of more powerful drives has not been tested or designed for. We do not take responsibility for using overpowered EDFs. Be careful with the powerplant.

You can use hot wire or dremel tool to prepare the EDF holder in the fuselage. Mount your EDF, push it well to the outtake and use screws to secure it in place. Measure the distance between intake channel and the EDF. Print the cover ring in measured length. Cut it off to the right dimension and use cable binder to secure it. Test your power unit.

### Top Power

Use top brand carbon EDF with excellent quality and sound, with ESC Jeti Mezon for perfect telemetry tuned setup.



### High Power

[12 Blade High-Performance 90mm EDF Unit](#) - high quality thrust and sound with [Turnigy 3553-1800 90mm EDF Brushless Fan Motor](#) and 100A ESC.



## Standard Power

[Dr Mad Thrust 11-Blade Alloy 90mm](#) - standard quality, not so nice sound.  
[Mount strap for 90mm Alloy DPS Fan](#)



**NOTE:** Our Dr Mad Thrust unit arrived without holder, probably you'll need it ordered separately [Mount strap for 90mm Alloy DPS Fan](#).

[See video guide #9](#)

You will need: [90mm EDF for 6s-8S Li-Pol, 3-4kg thrust, not so long body...](#)  
[Dr Mad Thrust 11-Blade Alloy 90mm EDF unit with 1750kv Motor - 90mm](#)  
or similar  
fitting screws

## 9.1. Cooling system

Keep your controller cold! Use strong enough 90 - 150 A ESC. Make a short flight and watch the controller temperature after landing. Cooling vents helps keep the airflow around ESC.

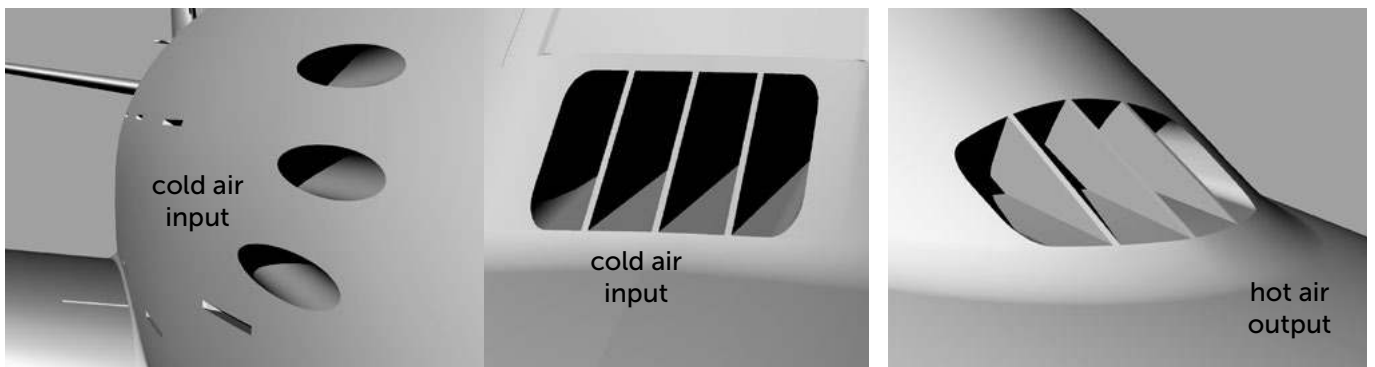

## 10. RC equipment and final assembly

Glue the controller holder and mount it to the fuselage. Install your receiver, connect battery, setup servos, etc. with your transmitter, check the throws on neutrals. Set recommended deflection according to the videoguide. Check CoG point (see CG- tags on wings). Use 820mm/32inch of 8mm carbon tube for wings reinforcement. Carbon tube marks CoG.

**Make sure the battery is placed properly and secured. If battery moves mid-flight it can shift the center of gravity and aircraft will become uncontrollable!**

You will need:

- Your own Rx/Tx system
- 2x 3S Li-Pol 4000mAh used as serial for 6S
- [80-100A Electronic Speed Controller](#)
- Adhesive velcro strip (or ZIP) for Li-Pol battery and ESC
- Scale markings printed on adhesive foil
- Battery bays fits [2900 - 6200mAh with 35x65mm](#) profile.

[See video guide #10](#)

battery maximal  
profile:  
**35 x 65 mm**  
**1.36 x 2.53 inch**

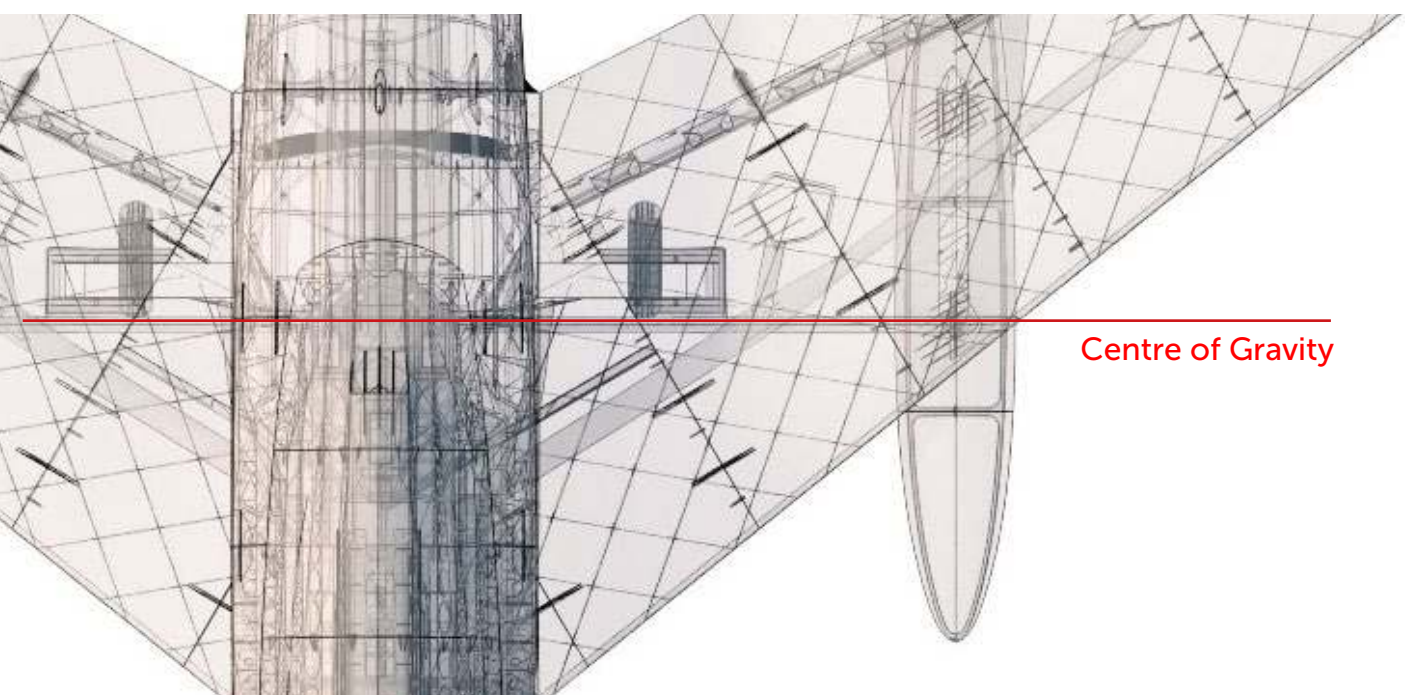

## 10.2. Flying setup

Setup flight modes on your RC system.

### Start mode

Flaps down for 15°, lower the undercarriage, 30% expo.

### Normal mode

all in neutral, lower/retract the undercarriage, 30% expo

### Fast Fly mode

all in neutral, retract the undercarriage, 40% expo, 70% elevator, rudder, ailerons

### Landing (butterfly) mode

lower the undercarriage, flaps full down 45°, ailerons up +15mm, elevator slightly down -5mm. 30% expo. You will need about half EDF power for perfect speed.

#### aileron

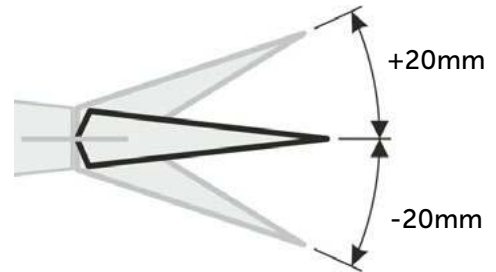

#### flap

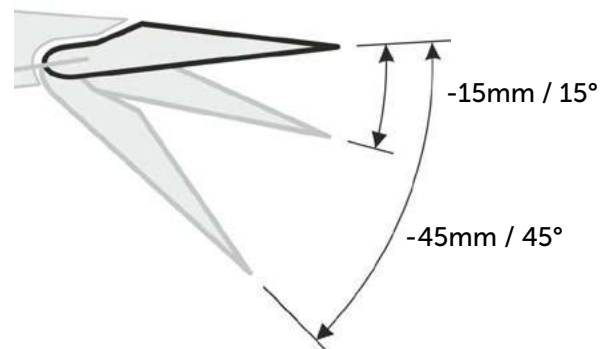

#### elevator

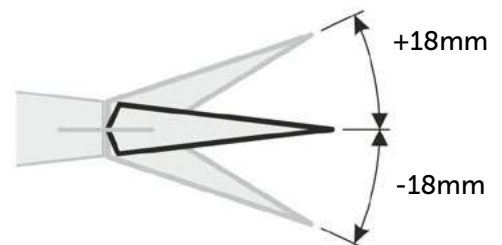

#### rudder

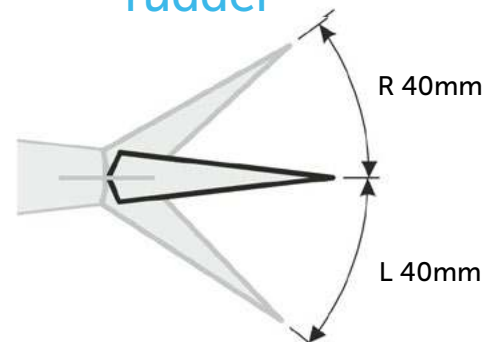

## 11. Pilots Please Attention!

For the first flights we recommend setting the center of gravity to around 5 mm forward of the CG tag - nose heavy, this increases the stability (you can use heavier battery). Also increasing the expo settings on your transmitter for elevator and aileron to 60 % calms the response from your stick inputs or you can decrease elevator and ailerons deflection.

Make sure the battery is well fixed in proper position. If it moves during flight it will cause the CoG move backwards and can lead to uncontrollable flight behavior.

When you feel comfortable, you can use the suggested balance of the aircraft, and set expo to 30-50 % ... to gain back extra maneuverability. This is not a beginner plane. Be sure you have enough experience flying RC models before attempting to fly this jet.

Spend at least 10 hours with RC flight simulator before you go out for the first time.

[Flite test: RC Planes for beginners](#) (but note: we use primary ailerons for turn, not only rudder)

[See your F-86A Sabre flight video!](#)

Please, use these files only for your own purpose, do not send it further. Thank you very much. Enjoy your flight.





## Shopping list

Printing material:	2,5 kg of <a href="#">PLA</a>
RC:	12 channel receiver by your RC system
EDF:	Use any 90mm EDF by your choice. We tested:  <a href="#">12 Blade High-Performance 90mm EDF Unit - high quality 3553-1800 90mm EDF Brushless Fan Motor</a>  <a href="#">Dr Mad Thrust 11-Blade Alloy 90mm - standard quality Mount strap for 90mm Alloy DPS Fan</a>  or similar for 6S Li-Pol with not so long body...
Controller:	<a href="#">80-100A Electronic Speed Controller</a>
Battery:	2x 3S or 4S Li-Pol 4200-6200mAh used as serial for 6S or 8S
Servos:	9x Hitec HS-81/82MG, <a href="#">Corona CS283MG</a> or similar servos 1x Hitec HS-65 MG or <a href="#">HobbyKing™ HK15178 Analog Servo</a> or similar 6x <a href="#">servo extension cables 300mm / 12 inch</a> 2x <a href="#">servo extension cables 500mm / 20 inch</a>
Retracts:	<a href="#">Electron retracts ER-30eVo</a> or  33mm x 35mm <a href="#">Servoless Retract with 4mm metal pins</a> . for main legs. For the nose leg 33mm x 35mm <a href="#">Servoless Nose Wheel Retract with 4mm metal pin</a> .
Legs:	<a href="#">Alloy Oleo Strut Set with Wheels and Rubber Tires</a> (main legs) <a href="#">Alloy Oleo Strut set w/wheels for 90mm/1.20 Class Jet</a> (one main as nose leg)
Glue:	<a href="#">CA Glue - medium or similar medium viscosity CA glue Activator for CA Glue</a> or similar,
Other:	8mm carbon tube 3x 0,8 mm / 14 AWG pushrod wires or carbon rods 5x 1,2 mm / 16 AWG pushrod wire fitting screws