

Item No.:FJ1071
Version No.:FJ1071-V01

Freewing MIDEL®
www.sz-freewing.com

F/A-18E SUPER HORNET



1030MM LENGTH

760MM WINGSPAN

64MM EDF JET

EN

1 ~ 10

中

11 ~ 20

  
MADE IN CHINA



Thanks for your purchasing our Freewing F/A-18E Super Hornet. F/A-18E is the main carrier-based fighter aircraft carrier in America today, this aircraft is the Navy's most important battle of a strike fighter.

This 64mm EDF jet F/A-18E Super Hornet produced from Freewing, it continues the excellent design of Freewing products---we are very easy to finish its assembly work within half an hour. The main wing, elevator, rudder, landing gear and other components, you can remove very easily, without damage.

This F/A-18E Super Hornet own excellent flight performance. Very scale appearance and detail decals, let this small size jet is more entertaining.

Please read the manual carefully to familiarize you with all the steps before starting.

⚠ NOTE: This is not a toy. Not for children under 14 years. Young people under the age of 14 should only be permitted to operate this model under the instruction and supervision of an adult. Please keep these instructions for further reference after completing model assembly.

Note:

1. This is not a toy! Operator should have a certain experience, beginners should operate under the guidance of professional players.
2. Before install, please read through the instructions carefully and operate strictly under instructions.
3. Cause of wrong operation, Freewing and its vendors will not be held responsible for any losses.
4. Model planes' players must be on the age of 14 years old.
5. This plane used the EPO material with surface spray paint, don't use chemical to clean, otherwise it will damage.
6. You should be careful to avoid flying in areas such as public places, high-voltage-intensive areas, near the highway, near the airport or any other place where laws and regulation clearly prohibit.
7. You cannot fly in bad weather conditions such as thunderstorms, snows....
8. Model plane's battery, don't allowed to put in everywhere. Storage must ensure that there is no inflammable and explosive materials in the round of 2M range.
9. Damaged or scrap battery should be properly recycled, it can't discard to avoid spontaneous combustion and fire.
10. In flying field, the waste after flying should be properly handled, it can't be abandoned or burned.
11. In any case, you must ensure that the throttle is in the low position and transmitter switch on, then it can connect the lipo-battery in aircraft.
12. Do not try to take planes by hand when flying or slow landing process. You must wait for landing stop, then carry it.

Assembling Data Index

Product basic information	2
Package list	2
Installing Plane	3
Battery	6
Power system	7
Center of Gravity	8
Servo introduction	8
Control surface direction and set up	9
Dual Rates	9
Troubleshooting Guide	10

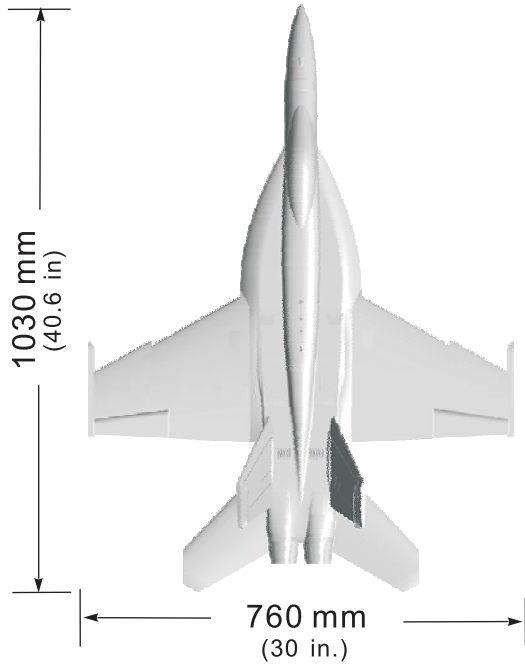

- Motor
2627-4300KV (Use for 11.1V 3S battery)
2836-3500KV (Use for 14.8V 4S battery)
- ESC
30A Brushless ESC (Use for 2627-4300KV Brushless motor)
40A Brushless ESC (Use for 2836-3500KV Brushless motor)
- Servo
9g Servos (5pcs)
- Battery
3S 11.1V 2200mAh 25C
4S 14.8V 2200mAh 25C
- Ducted fans
64mm EDF
- Take-off weight
780~980g (3S Battery/4S Battery)
(27.5~34.5 oz.)
- Thrust
650g (22.93 oz.) (For 3S Battery)
900g (31.75 oz.) (For 4S Battery)

Note: The parameters in here are derived from test result using our accessories. If use other accessories, the test result will be different. Any problem since of using other accessories, we are not able to provide technical support.

Landing Gear	Aileron	Flaps	Elevator	Rudder	Throttle
Yes	Yes	No	Yes	No	Yes

Package list



Different equipment include different spareparts. Please refer to the following contents to check your sparepart list.

PNP equipment list

1. Fuselage set (installed, include the electric parts and connection lines)
2. Main wing set (installed, include the electric parts and connection lines)
3. Tail wing set (installed, include the electric parts and connection lines)
4. Nose cone, tail vector.
5. Landing gear set (installed, include the electric parts and connection lines)
6. Pushord parts、Plastic parts
7. Screw
8. Glue、manual

KIT equipment list

1. Fuselage set
2. Main wing set
3. Tail wing set
4. Nose cone, tail vector.
5. Landing gear set
6. Pushord parts、Plastic parts
7. Screw
8. Glue、manual

Installing main wing

EN

Installing servo of main wing

1. Use glue to attach the "servo A" and "control surface horn C" on the indicated position.
2. Press the servo cable to the "trough D".
3. Use "pushrod B" to connect the servo arm and control surface horn.

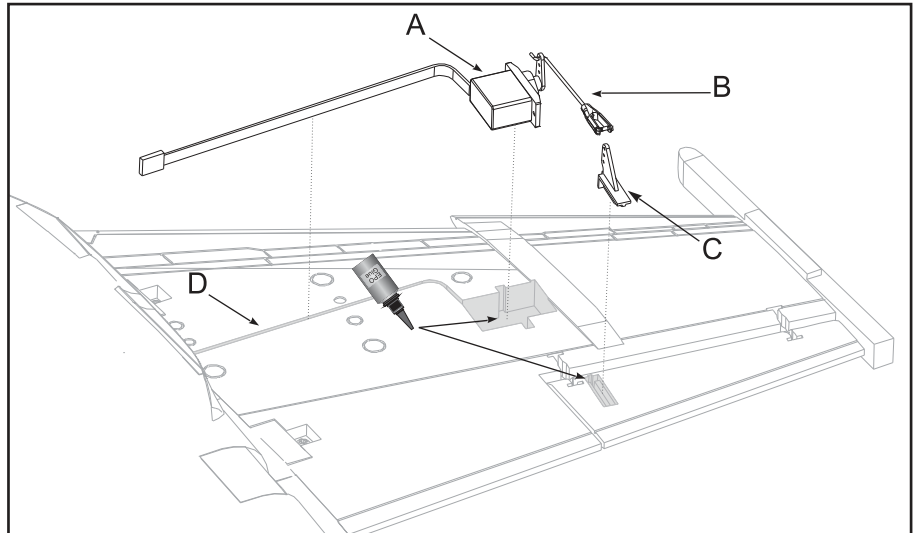

Aileron pushrod size

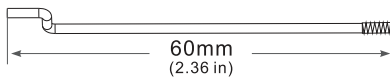

Pushrod Diameter : $\varnothing 1.2\text{mm}$

Aileron pushrod mounting hole

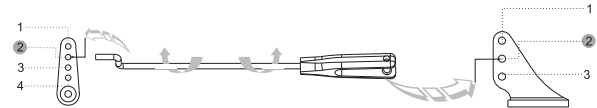

1. Remove the carbon tube from parts bag, insert the carbon tube into the fuselage.
2. Insert the left, right wing into fuselage, then fix it by 4pcs screws.

Carbon tube size: ($\varnothing 6 \times 213\text{mm}$ 2pcs)
Screws: (PWA3 \times 8mm 4pcs)

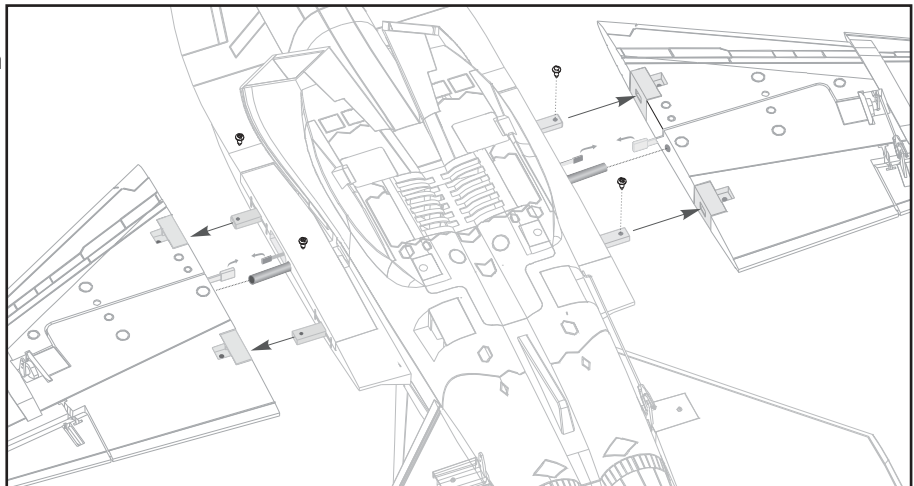

Installing the elevator

1. Insert the left/right elevator into full rotating shaft of "elevator B".
2. Fix the elevator by 2pcs "screws A".
3. Pull out the elevator by hand, test the elevator is fixed firmly or not.
4. Rotate the elevator by hand, test its smooth or not. If feel tightly, you can try to use the following way to improve:
 - Disassemble the elevator and install again.
 - Disassemble the elevator and use sandpaper to polish the rotating shaft.

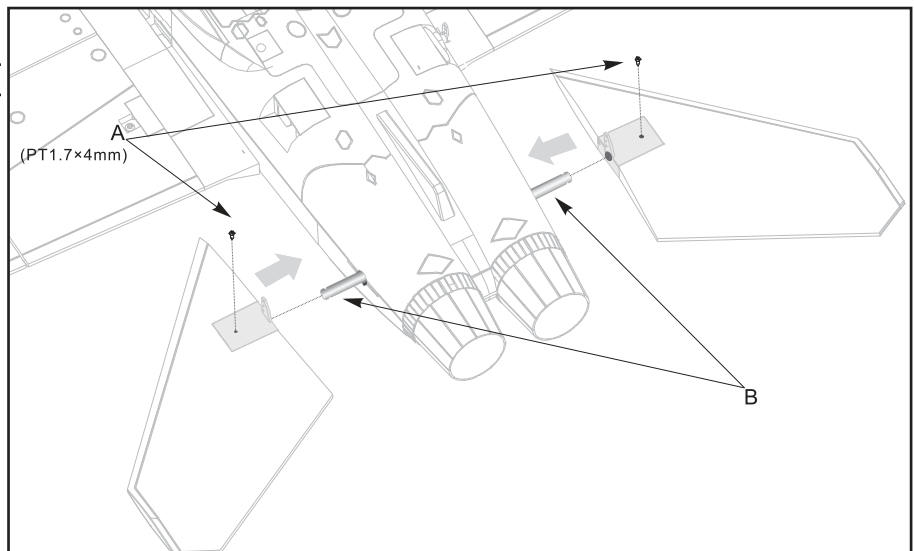

Remember you can't be over polished, and control the polished thickness within 0.05mm. If over polished, shaft will be smaller and happen absence space.

Installing the servo of elevator

1. Use glue to fix the “servo A” to indicated position.
2. Finish to install the servo, use glue to attach the “plastic cover B” well.
3. After finish to install the elevator, use “pushrod C” to connect the servo arm and elevator horn.

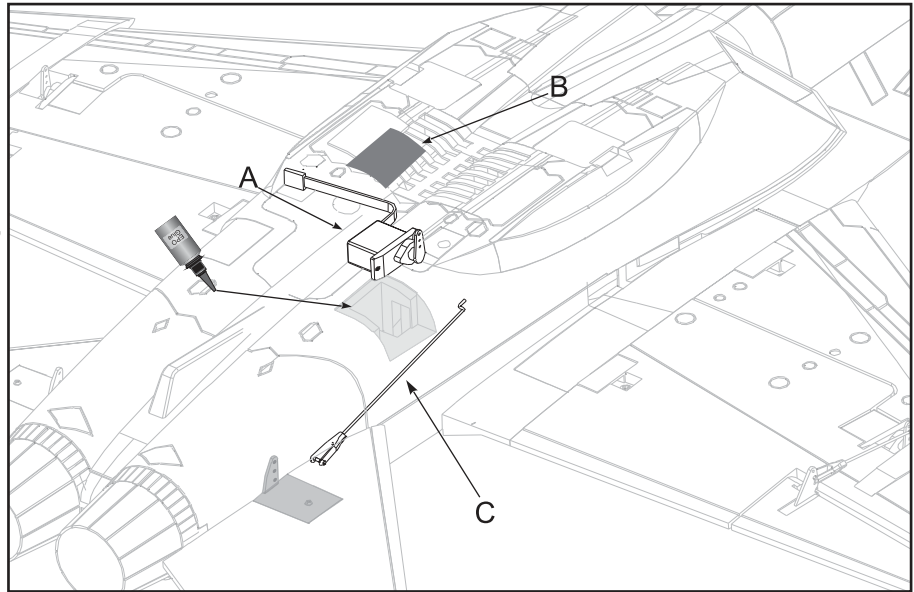

Elevator pushrod size

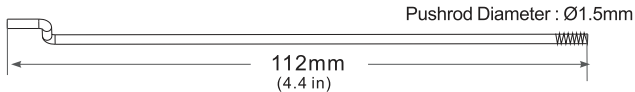

Elevator pushrod mounting hole

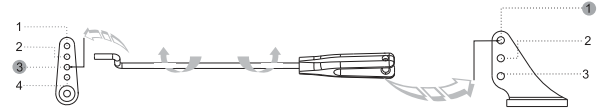

Installing rudder

1. As the right photo shown, use the glue to attach the left, right rudder.

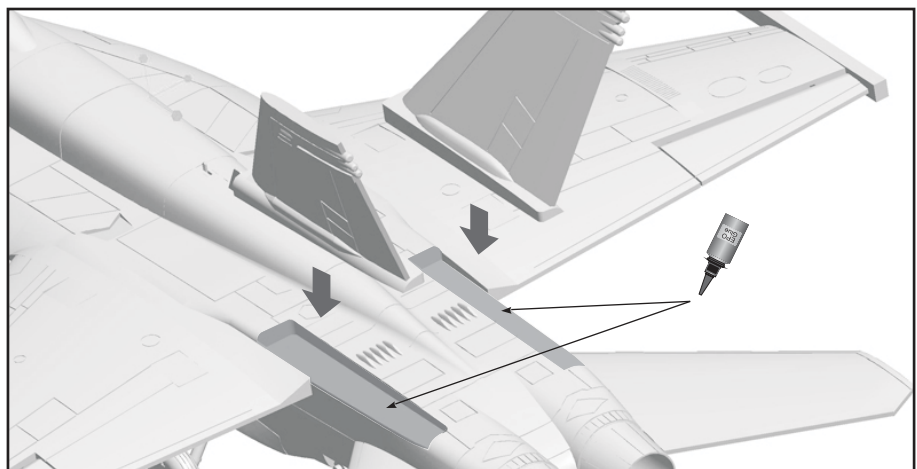

Installing nose cone

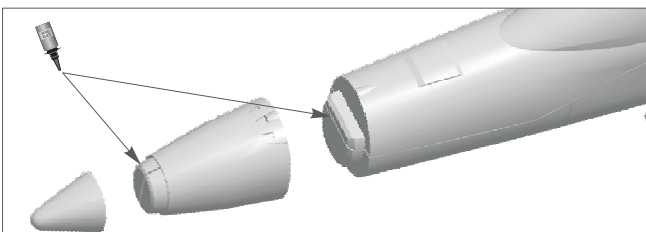

As the right photo shown, use the glue to attach the nose cone.

Installing the tail outlet

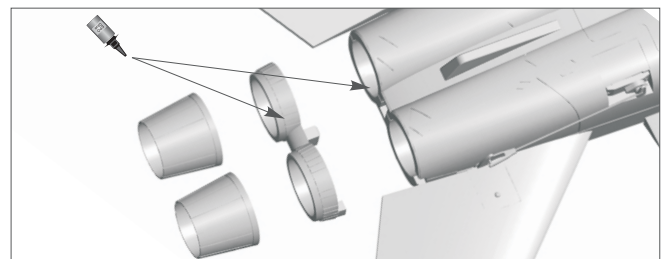

As the right photo shown, use the glue to fix the “8” shape foam part and plastic tail outlet on the fuselage.

Installing the wingtip pylons

EN

1. As the right photo shown, use the glue to fix the wingtip pylons on the main wing.

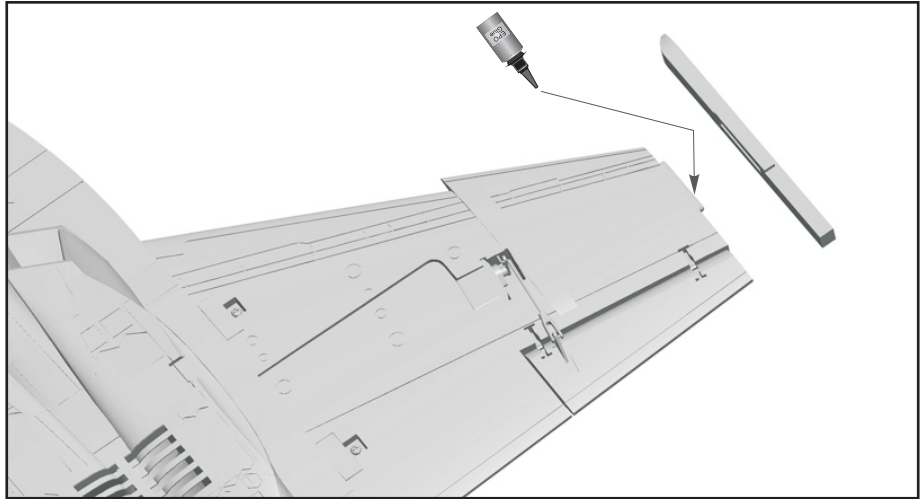

Installing nose landing gear

Accessories list:

- A-U-shape pushrod
- B-Servo steering arm
- C-Pushrod connecting part 1
- D-Servo (9g)
- E-Servo fixing mount of nose landing gear
- F-Nose landing gear metal wire
- G-U-shape connecting arm
- H-Slant support rod
- I-Pushrod connecting part 2
- J-Wheel shaft
- K-Wheel
- L-Jimi screw (Ø35×10mm)
- M-Screw (M3×3mm)
- N-Screw (PM2×4mm)
- O-Screw (PWA2×8mm)
- P-E-buckle (FA2.2×24mm)
- Q-E-buckle (Ø2.0mm)
- R-Pin (Ø1.5mm)
- S-Screw (Ø1.5mm)

1. Fix the "servo rotating arm (B)" to the "servo (D)" by "screws (M)".
2. Insert the "U shape pushrod (A)" into "servo steering arm (B)" and "pushrod connecting part 1 (C)" respectively, and use "Jimi screw (L)" to fix.
3. Insert the "servo (D)" into "servo fixing mount (E)" of nose landing gear and use "screws (N)" to fix.
4. One side of "Nose landing gear metal wire (F)" pass through the "servo fixing mount (E)" of nose landing gear, insert to the "pushrod connecting part 1 (C)" and use "jimi screw (L)" to fix.
5. Insert the other side of "nose landing gear metal wire (F)" to the pushrod connecting part 2 and use 2pcs "screws (L)" to fix.
6. Use "Jimi screw (L)", "E-buckle (P)" to fix the "wheel shaft (J)", and "wheel (K)".
7. Buckle the "U-shape connecting arm (G)" on the "nose landing gear metal wire (F)", use "Pin (R)", "E-buckle (Q)" to connect the "U-shape connecting arm (G)" and "slant support rod (H)".
8. Test and adjust the nose landing gear is in the center, and use "screw (O,S)" to fix the installed nose landing gear on the fuselage.

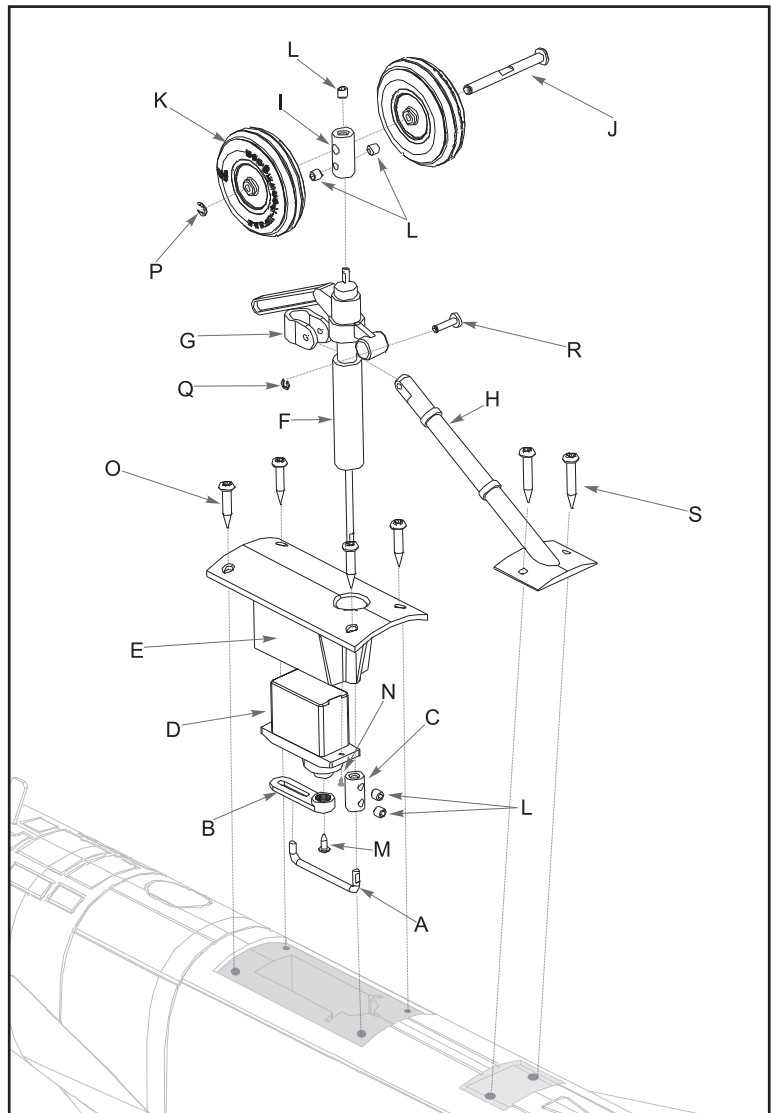

⚠ Note: When use Jimi screw to fix the pushrod connecting parts 1 and 2, we need to check the flat position of pushrod, its on the face of screw hole, it can fix effectively.

Accessories list

- A-Rear landing gear metal wire fixing mount.
- B-Rear landing gear metal wire
- C-Wheel
- D-Wheel shock
- E-Jimi screw

1. Use glue to fix the "rear landing gear metal wire fixing mount (A)" on the fuselage.
2. After the glue solidify, insert the left, right "landing gear metal wire (B)" in the "rear landing gear metal wire fixing mount (A)"
3. Put the "wheel (C)", "wheel shock (D)" on the left, right "rear landing gear metal wire (B)", and use 2pcs "jimi screws (E)" to fix the left, right "wheel shock (D)".

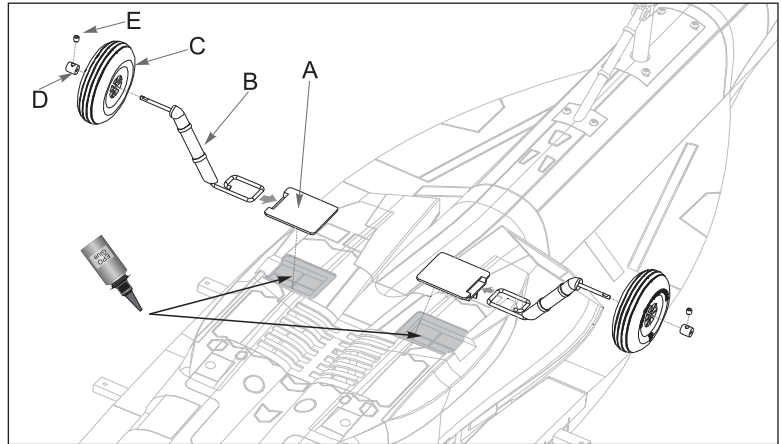

Install on battery

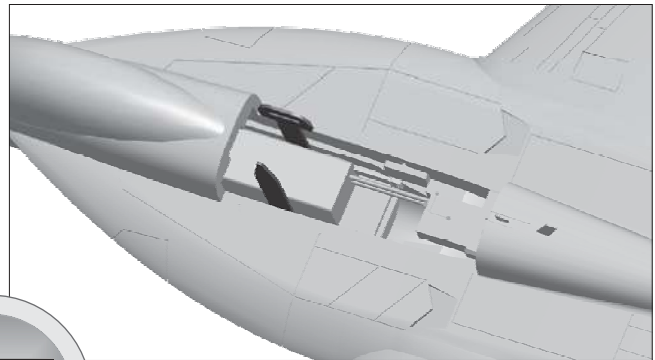
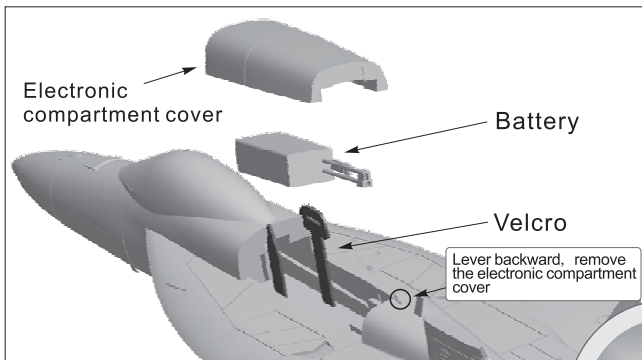

Lever backward, remove the electronic compartment cover, then use velcro to fix battery.

Before connect battery and receiver, please switch on the transmitter and check that the throttle is in the low position.

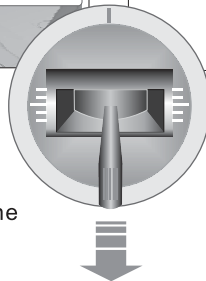

Our standard battery is :
3S 11.1V 2200mAh 25C or 4S 14.8V 2200mAh 25C
 You can choose the battery refer to the battery cabin size.
L=155mm W=43mm H=62mm
 The battery capacity and discharge rate we advise is in the following:
3S 11.1V 1800mAh ~ 3S 11.1V 2600mAh
4S 14.8V 1800mAh ~ 4S 14.8V 2600mAh
Discharge rate ≥ 25C

Different weight battery may affect its CG, please the correct range of CG indication.

1. Assemble motor (A) to the motor mount (B).
2. Fix the motor(A) by screws(C).
3. Insert the collet(D) into motor shaft.
4. Set backplate(E) into the collet(D).
5. Set the fan (F) into the collet(D).
6. Screw the collet(D) by nut(G) to fix the fan (F).
7. Put the assembled EDF (J) into fuselage.
8. Connect ESC and motor and sort out the wires of ESC and motor.
9. Cover the EDF cabin cover(I).
10. Fix it by 2pcs screws(H).

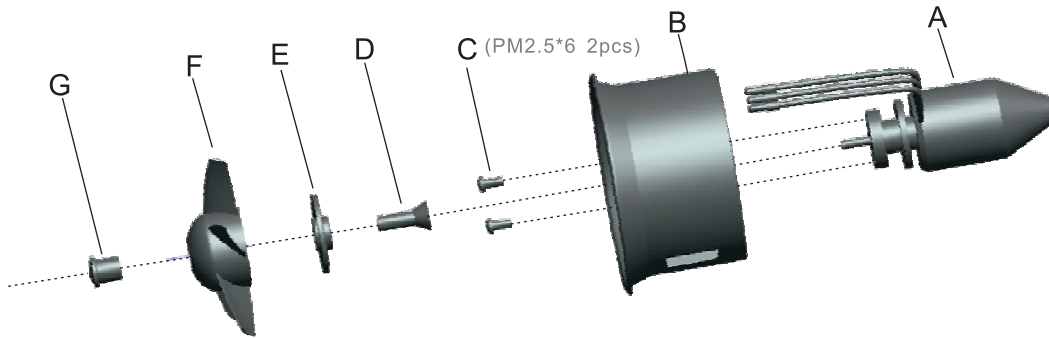

Note: When screw the nut(G), please don't screw too tight, if screw too tight, it may cause the damage of fan (F).

Note: When ESC and battery connected, prohibit to touch them by hand to avoid accidental injury. When test EDF, please use safety test stand for testing, prohibit to touch by hand for testing.

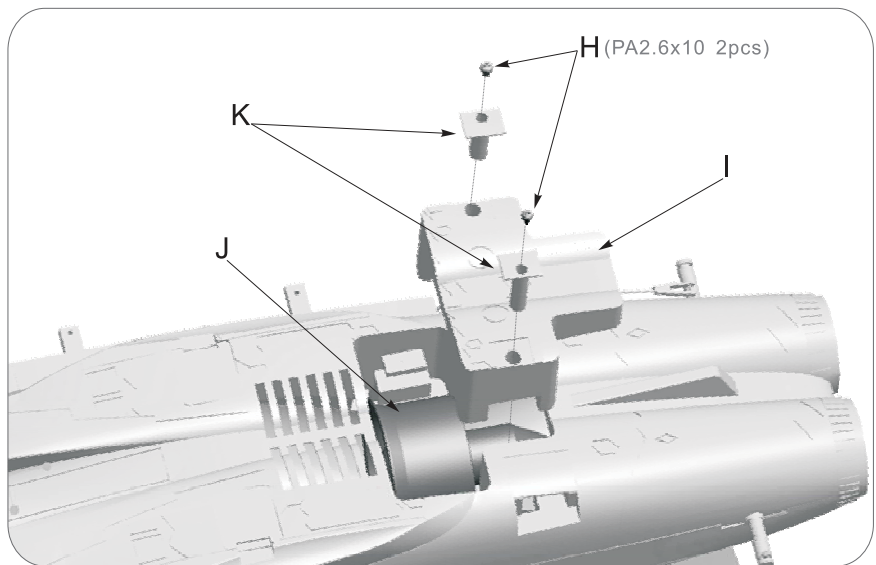

Motor parameters

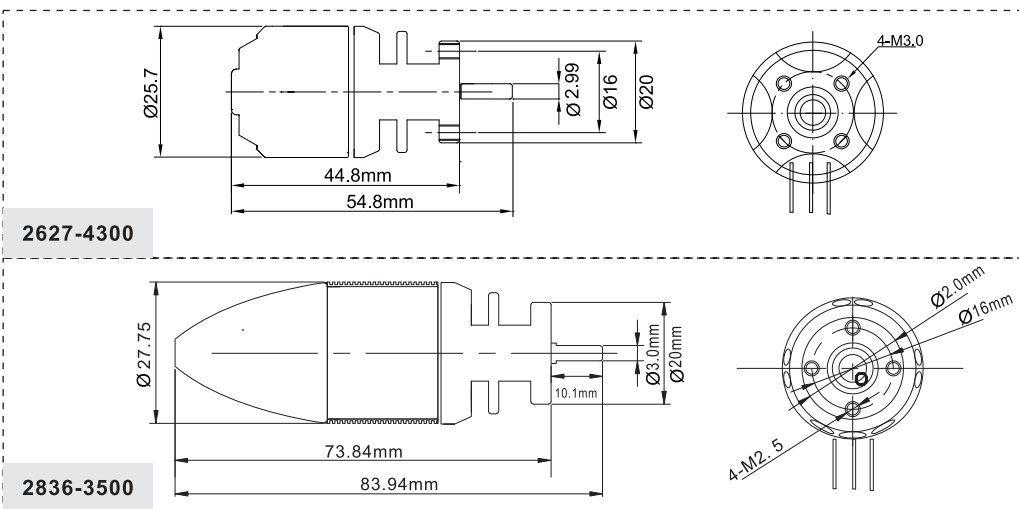

2627-4300KV brushless motor use 3S 11.1V lipo battery and 30A ESC

3826-3500KV brushless motor use 4S 14.8V lipo battery and 40A ESC.

Note: If you need other motor to use, please refer to the dimension shown on the left to select your motor, to make sure that the motor you purchased can install successfully.

Model	KV Value	Volate (V)	Current (A)	Pull (g)	RPM	Weight (g)	No Load Current	Propeller	ESC
2627-4300	4300RPM/V	11.1	22.1	680	47700	42	0.7A	64mm Ducted Fan	30A
2836-3500	3500RPM/V	14.8	32	900	51000	98	2.7A	64mm Ducted Fan	40A

Correct center of gravity is directly related to the success of the flight, please refer to the following CG diagram to adjust your plane's center of gravity.

- You can move the battery forward or backward to adjust the center of gravity.

-If you can not adjust the CG through move the battery, you can also use some other suitable material weight to counterweight, to make sure that CG is in the correct position.

**60 ~ 70mm
(2.36 ~ 2.75 in)**

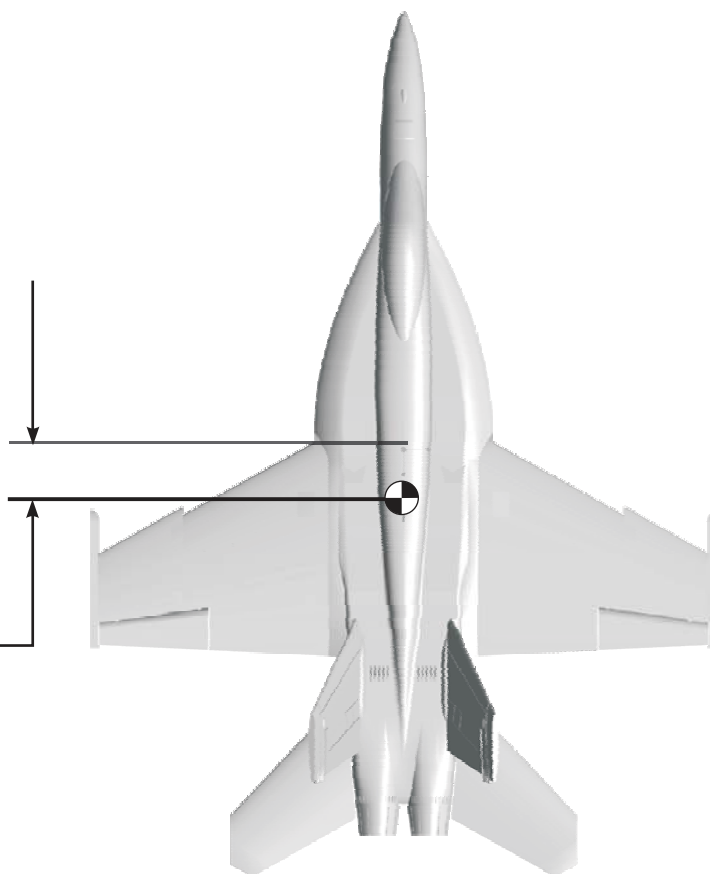

Servo introduction

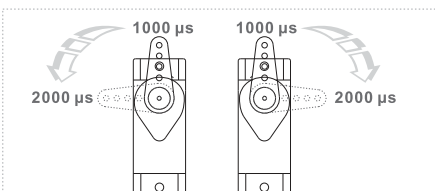

The servo positive or reverse rotation is defined as follows:
 When servo input signal change from 1000 μ s to 2000 μ s,
 The servo arm is **rotated clockwise, its positive servo.**
 The servo arm is **rotated counterclockwise, its reverse servo.**

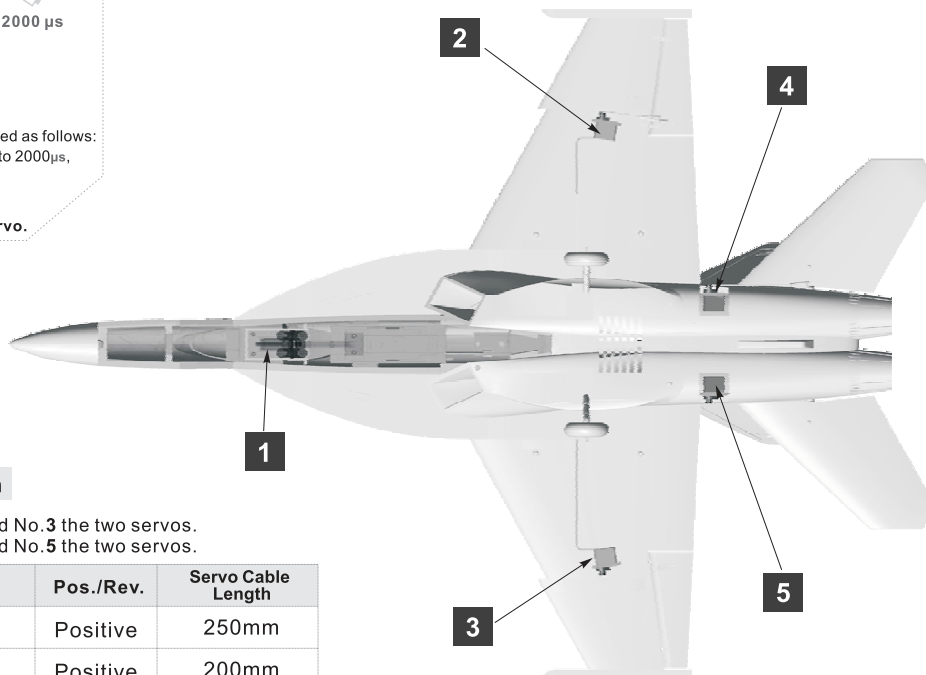

Servo connection instruction

1. Use Y-wire to connect the No.2 and No.3 the two servos.
2. Use Y-wire to connect the No.4 and No.5 the two servos.

Servo installing position	No.	Pos./Rev.	Servo Cable Length
Nose gear steering servo	1	Positive	250mm
Aileron servo	2	Positive	200mm
Aileron servo	3	Positive	200mm
Elevator servo	4	Positive	100mm
Elevator servo	5	Reverse	100mm

After installed the plane, before flying, we need a fully charged battery and connect to the ESC, then use radio to test and check that every control surface work properly.

Aileron

Stick Left

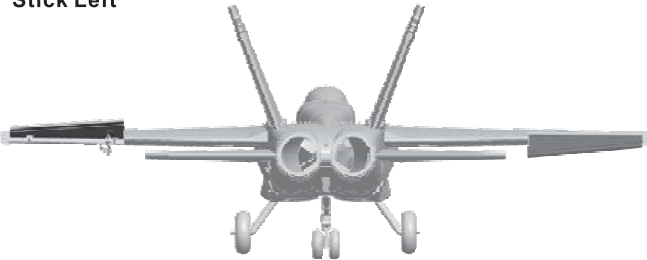

Stick Right



Elevator

Up Elevator



Down Elevator

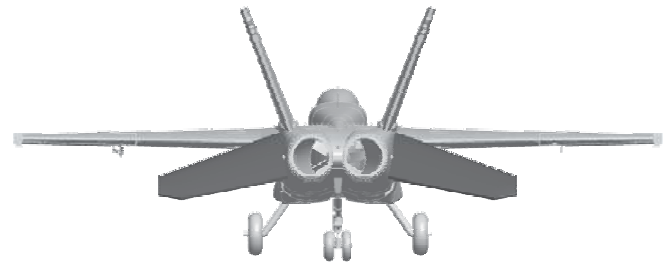

Rudder

Stick Left



Stick Right



Dual Rates

According to our testing experience, refer to the following parameters to set up control surface rate, it will be useful for your flight. You can choose a rate to fly according to your own circumstance.

Note : If your radio haven't the rate setup function, you can adjust the hole of control horn which connect with pushrod, to increase or decrease its rate.

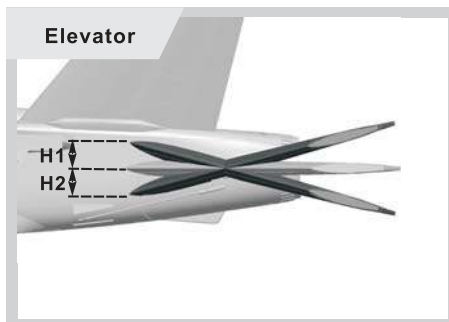
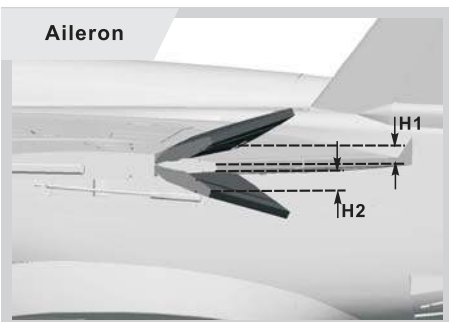

	High Rate	Low Rate
Aileron (H1, H2)	21mm	15mm
Elevator (H1, H2)	13mm	9mm

Motor does not turn on	A) Li-Po battery depleted	A) Recharge Li-Po battery
	B) Transmitter batteries depleted	B) Replace or recharge batteries
	C) Transmitter not turned on	C) Turn on transmitter
	D) Li-Po battery not plugged in	D) Plug in Li-Po battery
	E) Motor not armed	E) Arm motor
	F) A crash has damaged an internal component	F) Replace
	G) ESC or other damaged	G) Check ESC or contact local distributor
Cub is difficult to control	A) You are flying in too much wind	A) Fly when there is no wind
	B) Li-Po battery depleted	B) Recharge Li-Po battery
	C) Transmitter batteries depleted	C) Replace or recharge batteries
	D) Transmitter antenna not extended completely	D) Extend transmitter antenna completely
	E) Surface control rate is too high	E) Use low rate to fly
The nose always move down when fly, always need to up elevator	A) CG is forward	A) Adjust CG backward refer to instruction
Cub constantly climbs or descends, or turns right or left without control input	A) The aircraft is out of trim adjustment	A) Adjust the transmitter trim tabs
	B) You are flying in too much wind	B) Fly when there is no wind
Elevator is too flexible, up and down is not stable	A) CG is backward	A) Adjust CG forward refer to instruction
Plane will be slant when taxi on the runway	A) Nose gear is not center.	A) Center nose gear
	B) Rudder is not center.	B) Center rudder
Take off is difficult	A) Thrust is not on the high position	A) Thrust is on the high position
	B) Taxi distance is not enough	B) Long taxi distance
	C) Elevator rate is not enough high	C) Use high rate of elevator
Cub will not climb	A) Li-Po battery is depleted	A) Recharge Li-Po battery
	B) Ducted fan is damaged	B) Check and replace ducted fan
	C) Motor is damaged	C) Check and replace motor
	D) ESC overheat protection, power reduction.	D) Landing firstly, check and select a more powerful ESC
Li-Po battery is slightly warm after charging	A) This is normal	A) The Li-Po battery may be slightly warm when fully charged. It should not be hot to the touch.
Motor vibrates excessively	A) Ducted fan is damaged	A) Check and replace ducted fan
	B) Motor is damaged	B) Check and replace motor
	C) Ducted fan is not balance	C) Adjust the ducted fan balance
	D) High speed will happen slightly vibrate	D) Its normal to use
Control surface move the wrong direction	A) Servo direction is reversed	A) Adjust servo reversing function



Dongguan Freewing Electronic Technology Ltd
HK Freewing Model International Limited

Add.: FeiYi Building, face to Labor Bureau, Fumin Middle Road, Dalang Town,
Dongguan City, Guangdong Province, China

Web: <http://www.sz-freewing.com>

Email: freewing@sz-freewing.com

Tel: 86-769-82669669 Fax: 86-769-82033233

东莞市飞翼电子科技有限公司
香港飞翼模型国际有限公司

地址: 广东省东莞市大朗镇富民中路402-408号飞翼楼四楼

Web: <http://www.sz-freewing.com>

Email: freewing@sz-freewing.com

Tel: 86-769-82669669 Fax: 86-769-82033233

