



# FuntanaS™ .40

## ASSEMBLY MANUAL



### Specifications

Wingspan: .....	56 in (1422 mm)	Weight: .....	4–5.5 lbs (1.8 Kg–2.5 Kg)
Length: .....	56 in (1441 mm)	Radio: .....	4-channel w/5 servos
Wing Area: .....	714 sq in (46.1 sq dm)	Engines: .....	32–.46 2-stroke, .40–.72 4-stroke

The new FuntanaS™ .40 3D ARF was designed exclusively for Hangar 9® by Italy's most famous 3D pilot, Sebastiano Silvestri. He based the FuntanaS on his highly successful KatanaS TOC design. The result is a budget-friendly .40-size airplane with unlimited 3D performance.

The FuntanaS can do it all—harriers, torque rolls, blenders, and almost anything else you can dream up. It's all possible, thanks to an extremely lightweight, all-wood airframe and big control surfaces that give the FuntanaS a very impressive thrust to weight ratio and crisp control authority at any airspeed. Sebastiano's signature UltraCote® trim scheme and factory painted parts such as the cowl and wheel pants complement the performance perfectly.



© 2005, Horizon Hobby, Inc.  
4105 Fieldstone Road  
Champaign, Illinois 61822  
(217) 355-9511  
www.horizonhobby.com

# Table of Contents

Table of Contents .....	2
Additional Required Equipment .....	3
Contents of Kit .....	3
Additional Required Tools and Adhesives .....	4
Other Items Needed (not included in the kit) .....	4
Warning .....	4
Before Starting Assembly .....	5
Using the Manual .....	5
Warranty Information .....	5
Section 1: Attaching the Wing to the Fuselage .....	6
Section 2: Installing the Horizontal Stabilizer .....	7
Section 3: Installing the Vertical Stabilizer .....	10
Section 4: Installing the Ailerons .....	12
Section 5: Installing the Elevators .....	14
Section 6: Installing the Tail Wheel .....	16
Section 7: Installing the Rudder .....	18
Section 8: Engine Installation .....	20
Section 9: Throttle Pushrod Installation .....	21
Section 10: Fuel Tank Assembly .....	22
Section 11: Fuel Tank Installation .....	24
Section 12: Electric Motor Installation .....	25
Section 13: Cowling Installation .....	26
Section 14: Landing Gear Installation .....	28
Section 15: Radio Installation .....	30
Section 16: Linkage Installation .....	34
Section 17: Canopy and Decal Installation .....	39
Adjusting the Engine .....	40
Control Throws and Center of Gravity .....	40
Preflight at the Field .....	40
2003 Official AMA National Model Aircraft Safety Code .....	41

# Contents of Kit

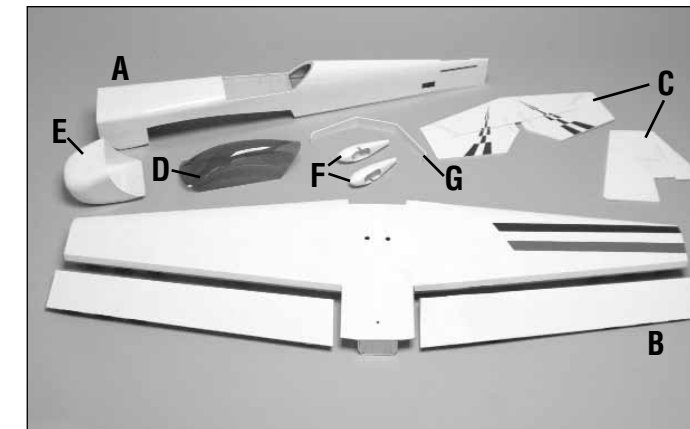

## Large Parts

A. Fuselage	HAN1977
B. Wing	HAN1976
C. Tail Set	HAN1978
D. Canopy	HAN1979
E. Cowl	HAN1981
F. Wheel Pants	HAN1982
G. Landing Gear	HAN1983

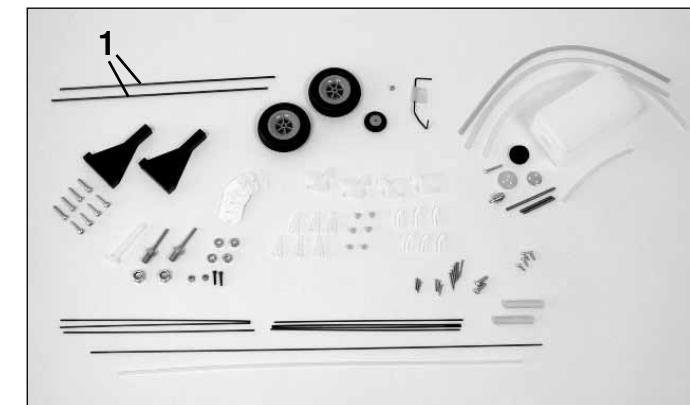

## Small Parts

1. Carbon Fiber Tail Support Rods	HAN1980
-----------------------------------	---------

## Additional items sold separately

Decal Set (not shown)	HAN1984
-----------------------	---------

# Additional Required Equipment

## Radio Equipment

- 4-channel radio system (minimum)
- 5 standard servos (JRPS537 recommended or equivalent)

## Recommended JR™ Systems

- PCM10X
- XP8103
- X-378
- XP662
- XF631



## Recommended Engines

- .40-.48 2-stroke
- .40-.72 4-stroke



## Additional Required Tools and Adhesives

---

### Tools

- Canopy Scissors
- Drill
- Drill bit: 1/16", 1/8"
- Flat blade screwdriver
- Foam: 1/4"
- Hobby knife
- Masking tape
- Phillips screwdriver (large)
- Phillips screwdriver (small)
- Pliers
- Ruler
- Sandpaper
- Square

### Adhesives

- 6-minute epoxy
- 30-minute epoxy
- Thin CA (cyanoacrylate) glue
- Thick CA (cyanoacrylate) glue
- CA remover/debonder
- Pacer Z-42 Threadlock
- Canopy glue (RC-56)
- Masking tape (3M blue recommended)

### Other Required Items

- Epoxy brushes
- Felt-tipped pen or pencil
- Measuring device (e.g. ruler, tape measure)
- Mixing sticks for epoxy
- Paper towels
- Petroleum jelly
- Radio packing foam
- Rubbing alcohol
- Sanding bar
- Sandpaper (medium)
- String
- T-pins
- Wax paper

## Other Items Needed (not included in the kit)

---

- Propeller (low pitch, large diameter recommended)
- 537 Standard Servo (JRPS537) (5) or equivalent
- 9" Servo Lead Extension (JRPA097) (2)
- 12" Servo Lead extension (JRPA098) (2)
- Large servo arm (JRPA212) (2)

## Warning

---

An RC aircraft is not a toy! If misused, it can cause serious bodily harm and damage to property. Fly only in open areas, preferably at AMA (Academy of Model Aeronautics) approved flying sites, following all instructions included with your radio and engine.

## Before Starting Assembly

---

Before beginning the assembly of the FuntanaS™, remove each part from its bag for inspection. Closely inspect the fuselage, wing panels, rudder, and stabilizer for damage. If you find any damaged or missing parts, contact the place of purchase.

If you find any wrinkles in the covering, use a heat gun or covering iron to remove them. Use caution while working around areas where the colors overlap to prevent separating the colors.

## Using the Manual

---

This manual is divided into sections to help make assembly easier to understand, and to provide breaks between each major section. In addition, check boxes have been placed next to each step to keep track of each step completed. Steps with two boxes indicate that the step will require repeating, such as for a right or left wing panel, two servos, etc. Remember to take your time and follow the directions.

## Warranty Information

---

Horizon Hobby, Inc. guarantees this kit to be free from defects in both material and workmanship at the date of purchase. This warranty does not cover any parts damage by use or modification. In no case shall Horizon Hobby's liability exceed the original cost of the purchased kit. Further, Horizon Hobby reserves the right to change or modify this warranty without notice.

In that Horizon Hobby has no control over the final assembly or material used for the final assembly, no liability shall be assumed nor accepted for any damage of the final user-assembled product. By the act of using the product, the user accepts all resulting liability.

Once assembly of the model has been started, you must contact Horizon Hobby, Inc. directly regarding any warranty question that you have. Please do not contact your local hobby shop regarding warranty issues, even if that is where you purchased it. This will enable Horizon to better answer your questions and service you in the event that you may need any assistance.

If the buyer is not prepared to accept the liability associated with the use of this product, the buyer is advised to return this kit immediately in new and unused condition to the place of purchase.

Horizon Hobby  
4105 Fieldstone Road  
Champaign, Illinois 61822  
(217) 355-9511  
www.horizonhobby.com

## Section 1: Attaching the Wing to the Fuselage

### Required Parts

- Wing
- Fuselage
- 1/4-20 x 2" nylon bolt
- 1/4" x 1 1/2" wing dowel (2)

### Required Tools and Adhesives

- 6-minute epoxy
- Sandpaper
- Flat blade screwdriver

This is one of the easiest sections of this manual. Too bad you need to use epoxy, which means you'll have some waiting to do along the way.

### Step 1

Locate the 1/4" x 1 1/2" wing dowels. Sand a small taper on one end of the dowel to make it easier to attach the wing to the fuselage.

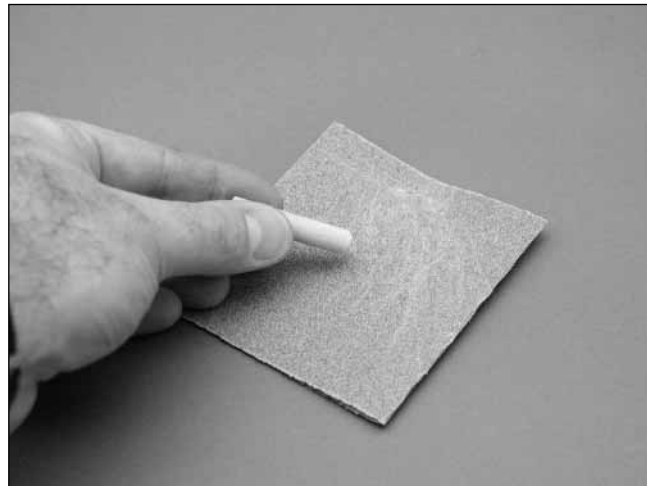

### Step 2

Glue the dowels into the wing using 6-minute epoxy. Make sure there is around 1/2" of the dowel exposed.

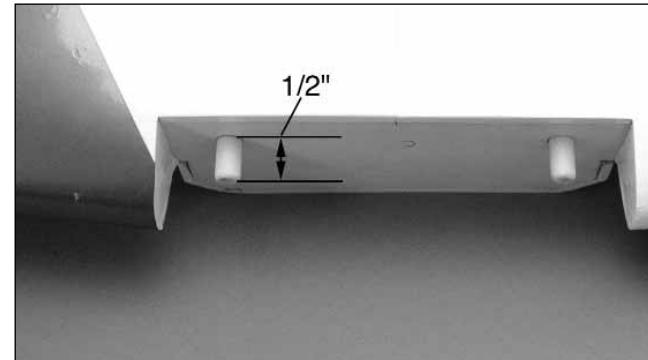

### Step 3

Place the wing onto the fuselage. Secure the wing using the 1/4-20 x 2" nylon bolt.

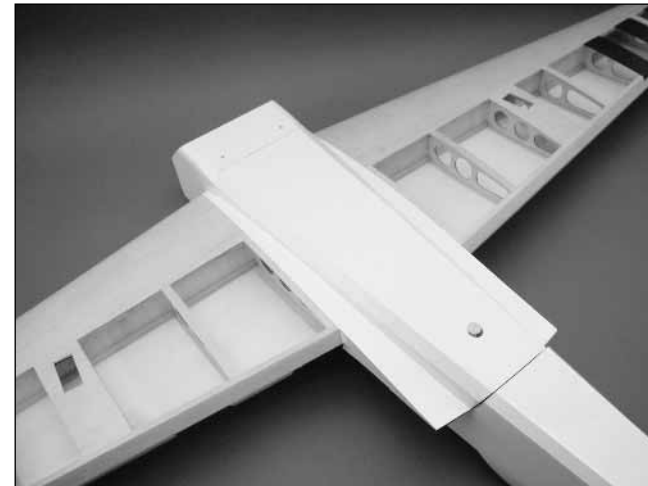

## Section 2: Installing the Horizontal Stabilizer

### Required Parts

- Wing
- Fuselage
- Horizontal stabilizer
- Elevator joiner wire
- Carbon fiber tail support rods

### Required Tools and Adhesives

- Thin CA
- Medium CA
- Flat blade screwdriver
- Sandpaper
- Drill
- Drill Bit: 3/32"
- Felt-tipped pen

Installing the horizontal stabilizer (stab) requires three easy alignment steps, removing some covering, and applying a little CA.

### Step 1

Slide the stab into the fuselage. Center the stab in the opening by measuring the distance from the fuselage to each tip. The stab is aligned when both measurements are identical.

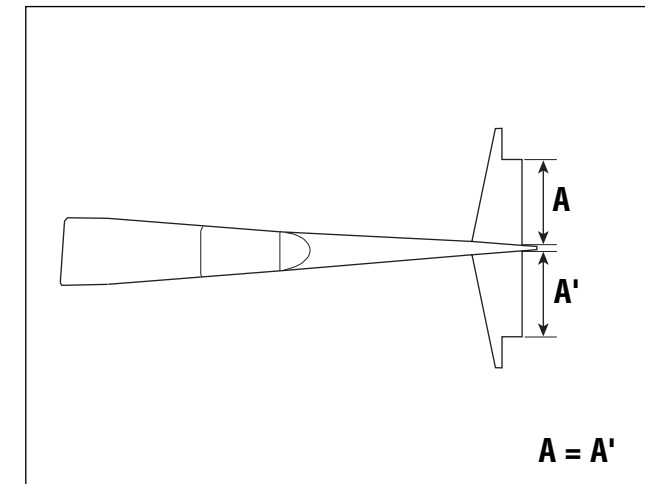

### Step 2

Check the distance from each stab tip to each wing tip. Remember to measure right-to-right, left-to-left. It won't work the other way around. These measurements must also be equal.

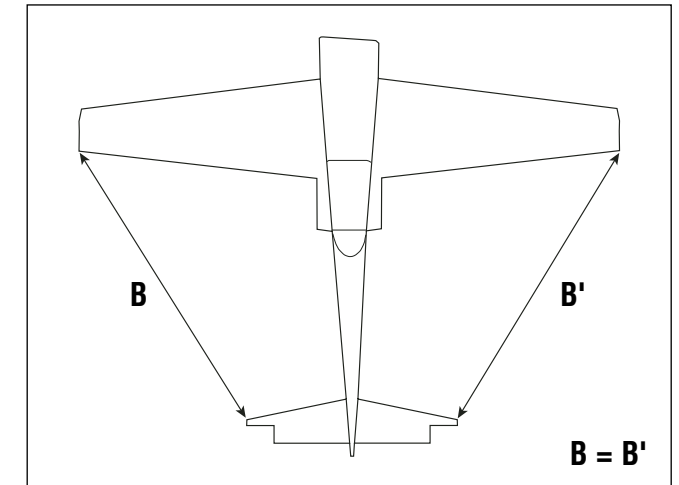

### Step 3

The last alignment step is making sure the wing and stabilizer are parallel. If they are not, lightly sand the opening in the fuselage for the stab until the stab rests parallel to the wing.

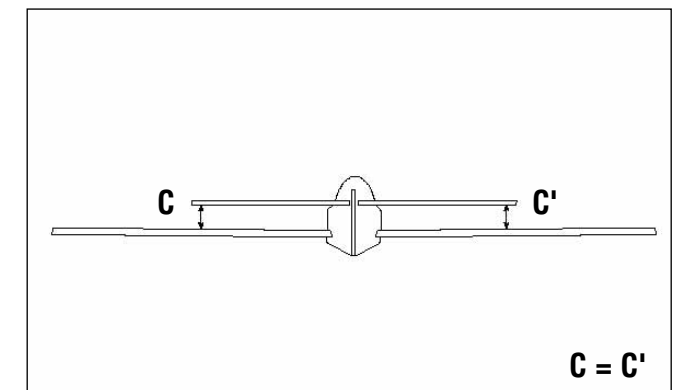

## Section 2: Installing the Horizontal Stabilizer

### □ Step 4

Use a felt-tipped pen to trace the outline of the fuselage on the stab.

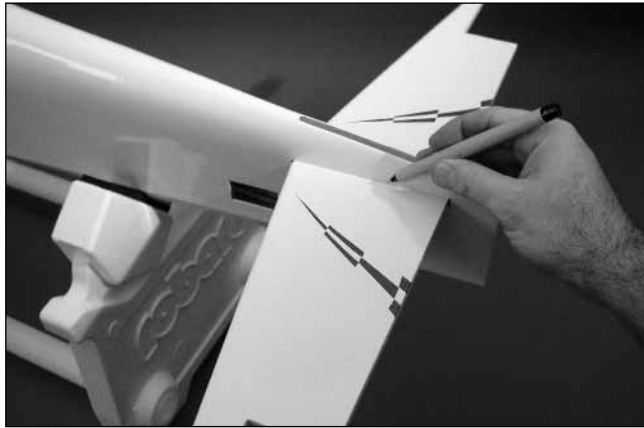

### □ Step 5

Remove the stab and use a hobby knife with a brand new blade to remove the covering 1/16" inside the lines just drawn.

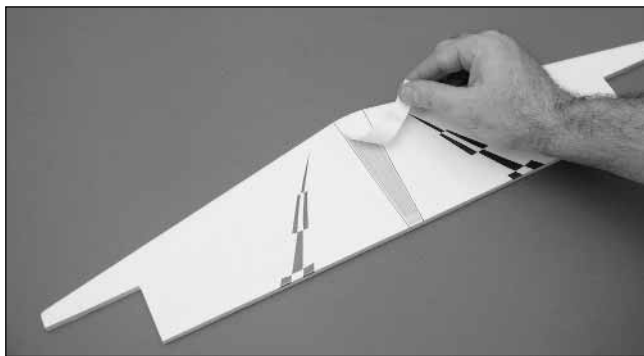
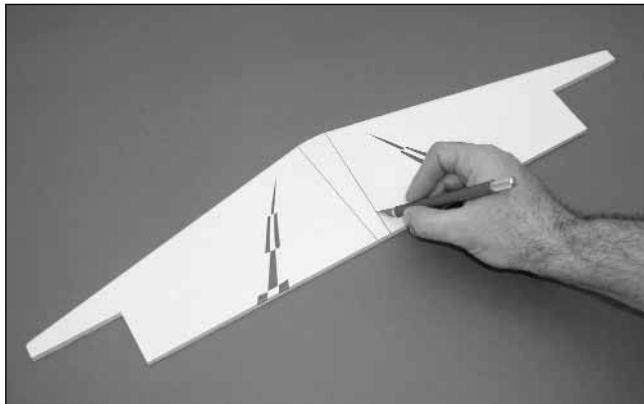

**Note:** Use care not to cut into the underlying wood and weaken the structure. Doing so will almost guarantee stab failure in flight, which is not a good thing.

### □ Step 6

Place the elevator joiner wire into the slot for the stab. Reposition the stab into the fuselage. It may be necessary to trim the opening at the rear to allow for clearance for the joiner wire.

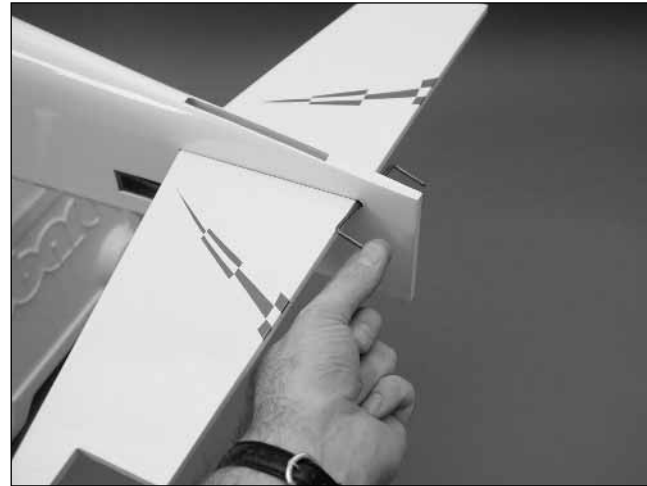

**Cool Tip:** Use a little rubbing alcohol and a paper towel to remove those nasty felt-tipped marker lines once they are no longer needed.

### □ Step 7

Double-check the alignment, to verify it's correct. Apply thin CA to the top and bottom of the joint between the fuselage and stab. Allow the CA to cure naturally; do not use accelerator. After a couple of minutes, apply a thin bead of medium CA to the joint to fill any gaps and to fuel-proof the joint.

**Cool Tip:** Use a little masking tape to keep the joiner wire from flopping around until it's time to install the elevators.

## Section 2: Installing the Horizontal Stabilizer

### □ □ Step 10

Mark the bottom of the stab using a felt-tipped pen. The mark will be 1 3/8" from the tip of the stab and centered fore-aft.

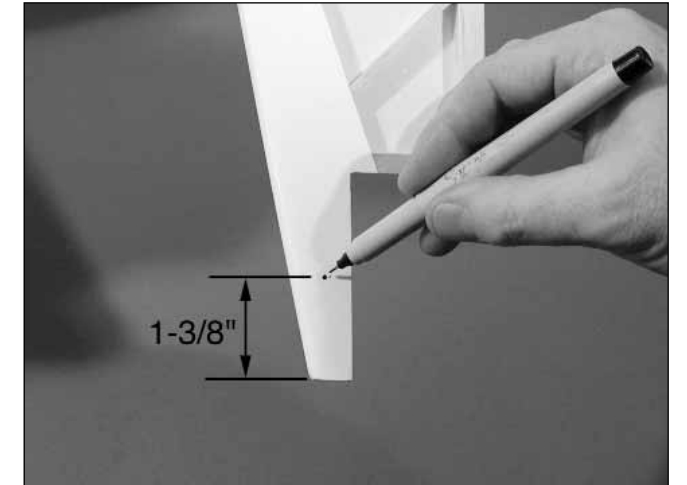

### □ □ Step 11

Place the carbon tail support into the hole drilled in the fuse. The other end of the rod should line up on the mark made in the previous step. Trace the angle of the rod onto the bottom of the stab for about 1/4".

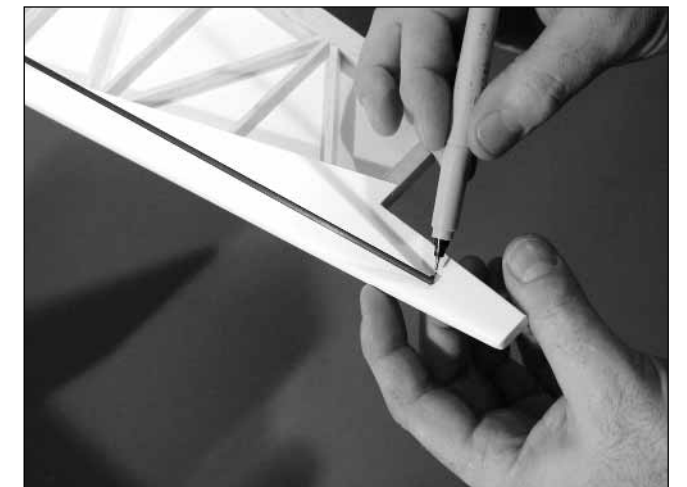

### □ □ Step 8

Mark the location for the carbon fiber tail support rods. They will be positioned 2 1/8" below the stab, and in-line with the leading edge of the stab. The goal is to butt them against the former that is in front of the stab.

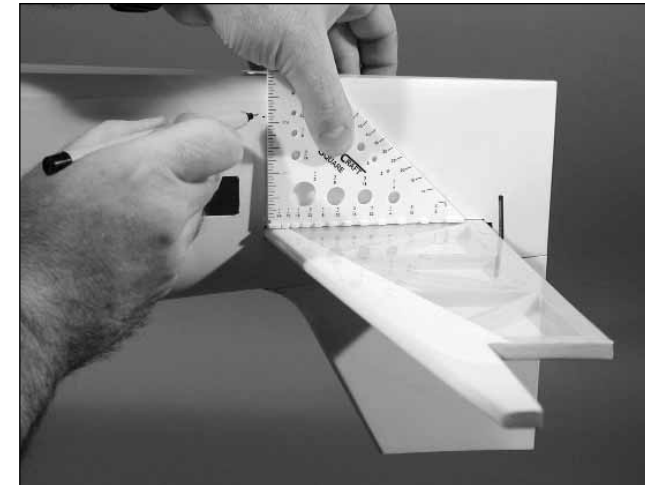

### □ □ Step 9

Drill the location marked in the previous step using a 3/32" drill bit.



## Section 2: Installing the Horizontal Stabilizer

### Step 12

Carefully cut a notch into the stab along the line drawn. The goal is to have the end of the carbon rod rest in the slot. The notch will be roughly 3/32"–1/8" deep.

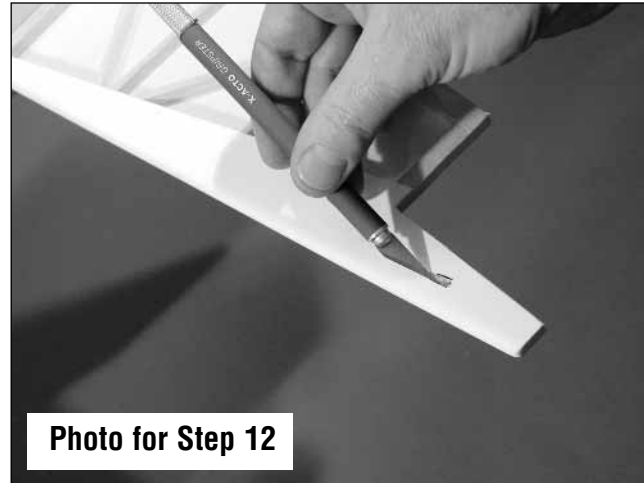
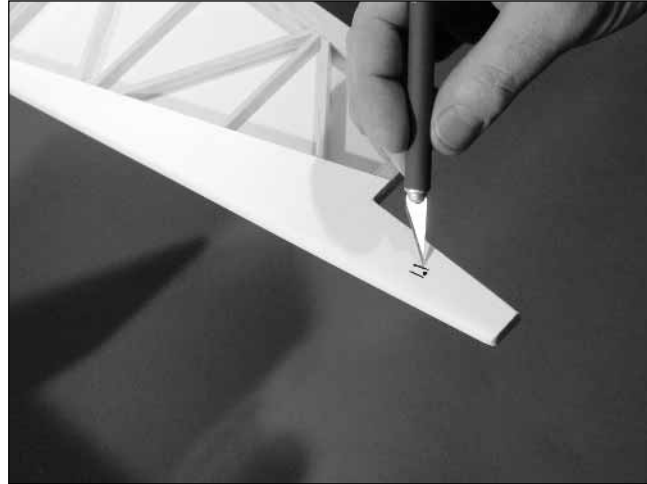

Photo for Step 12

### Step 13

Roughen up about 1/4" of each end using sandpaper. Test fit the carbon support rod on the fuse and stab. Use medium CA to glue the rod into position.

### Step 14

Repeat Steps 8 through 13 for the remaining support rod.

## Section 3: Installing the Vertical Stabilizer

### Required Parts

- Wing
- Fuselage
- Vertical stabilizer

### Required Tools and Adhesives

- 30-minute epoxy
- Sandpaper
- Square
- Ruler

The vertical stabilizer (fin) is a bit easier to install than the stab. There is still some alignment that must be done, but it is a lot less tricky.

### Step 1

Locate the vertical stabilizer (fin) and slide it into position. Position the fin so it aligns with the aft end of the fuselage. Use a ruler to check the alignment.

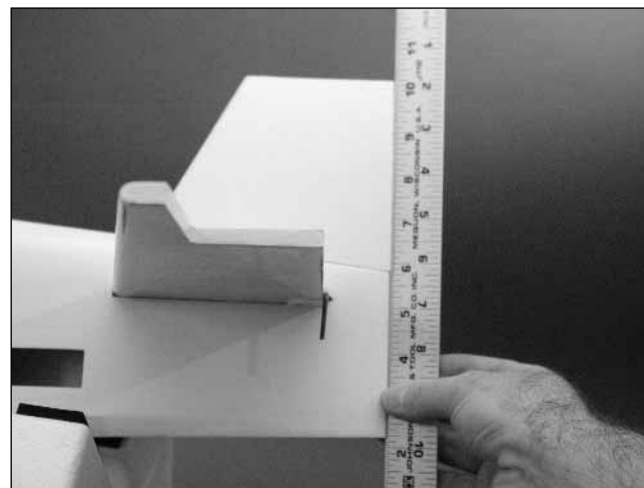

### Step 2

Check the alignment between the fin and stab. The fin must be 90 degrees to the stab to be in alignment. Sand the opening in the fuselage slightly if necessary to get the perfect alignment.

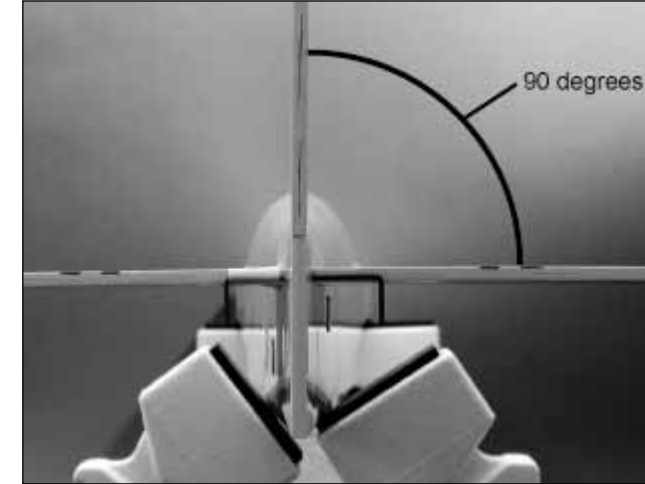

### Step 3

Trace the outline of the fuselage onto the fin.

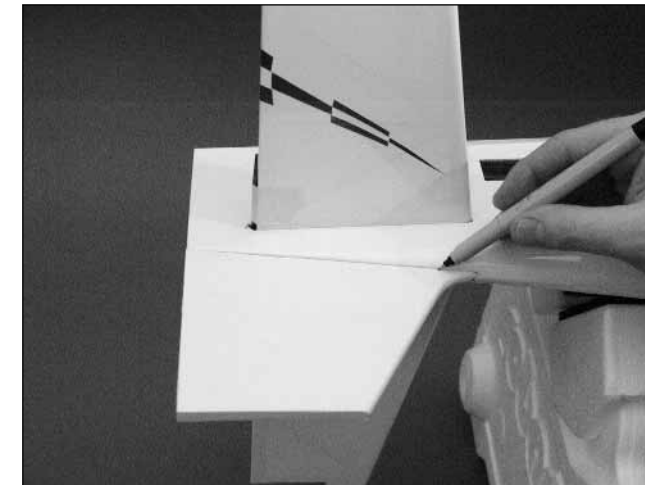

### Step 4

Remove the covering 1/16" below the line drawn in the last step.

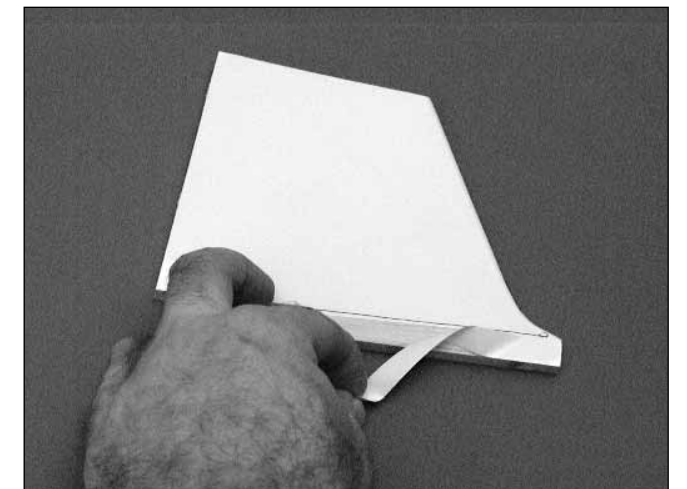
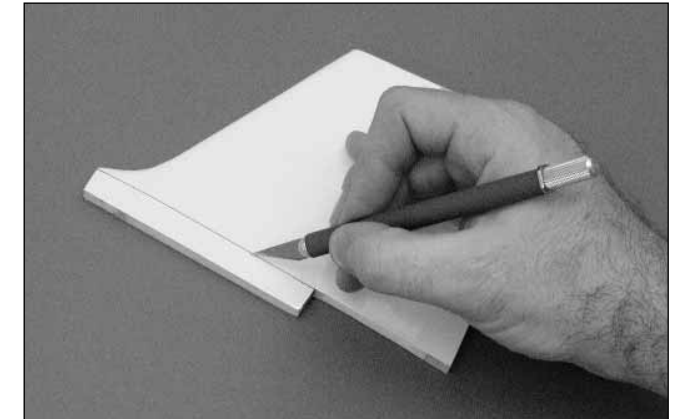

### Step 5

Use a ruler to draw two lines from the end of the slot onto the fuselage as shown.

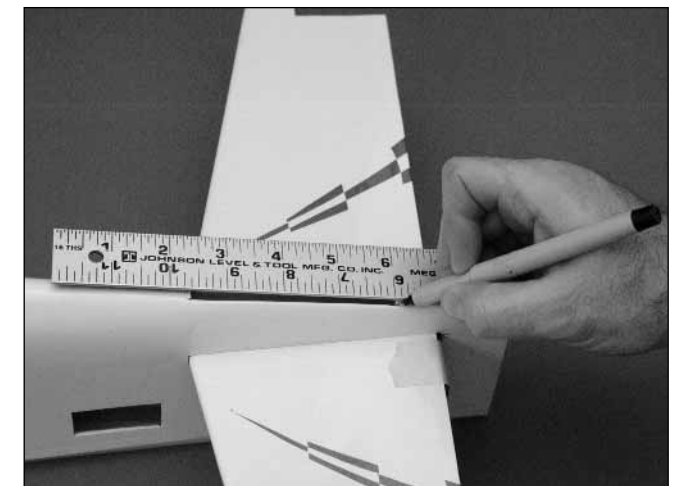

## Section 3: Installing the Vertical Stabilizer

### □ Step 6

Use a sharp hobby knife to remove the covering from between the lines drawn in the last step.

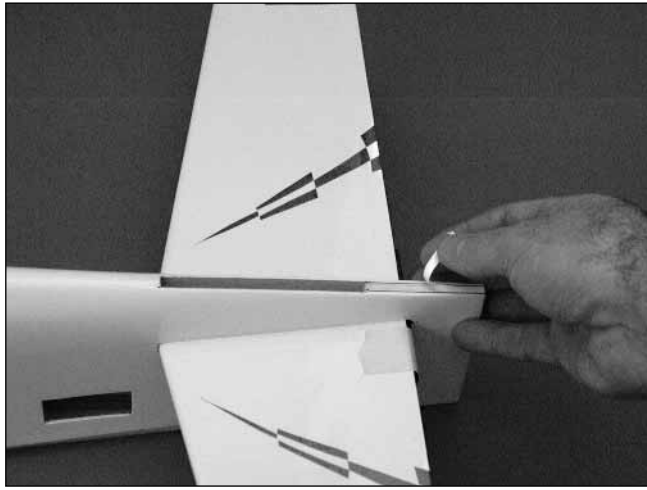

### □ Step 7

Mix 1/2 ounce of 30-minute epoxy. Apply the epoxy to the tab on the fin and to the area on the top of the fuselage where the covering was removed. Position the fin in the slot and check the alignment. Use masking tape to hold the fin in position until the epoxy fully cures.

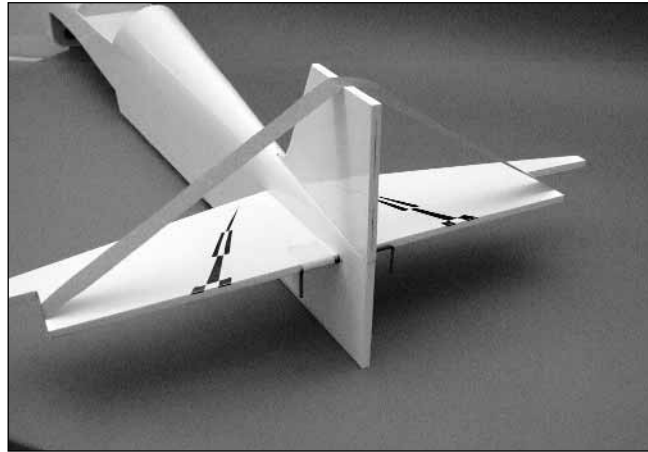

**Cool Tip:** Use rubbing alcohol and a paper towel to clean up any excess epoxy. Remember, this only works before the epoxy cures.

## Section 4: Installing the Ailerons

### Required Parts

- Wing
- CA hinges (10)
- Aileron (left and right)

### Required Tools and Adhesives

- Thin CA
- T-Pins

We recommend that you use the hinges provided. They work extremely well when installed as described. Even though the ailerons are large, we had absolutely no problems.

### □ □ Step 1

Locate 10 of the CA hinges. Place a T-pin in the center of five of the hinges.

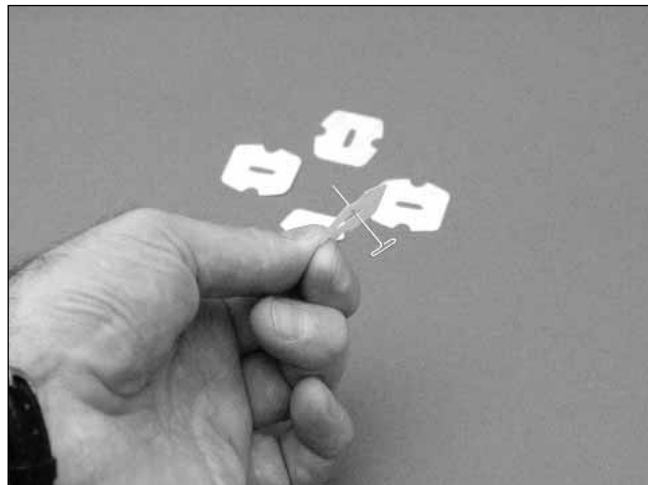

### □ □ Step 2

Place the hinges in the precut slots in the aileron (or wing if you prefer). The T-pin will rest against the edge when installed correctly.

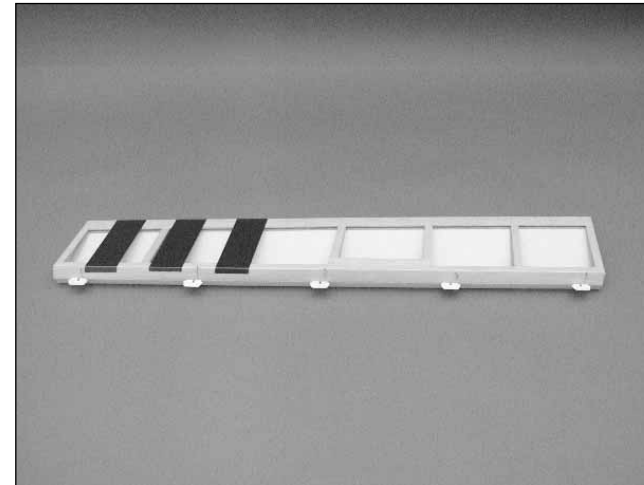

### □ □ Step 3

Slide the aileron and wing together. The gap between the aileron and wing should be nearly infinitely small, approximately 1/64".

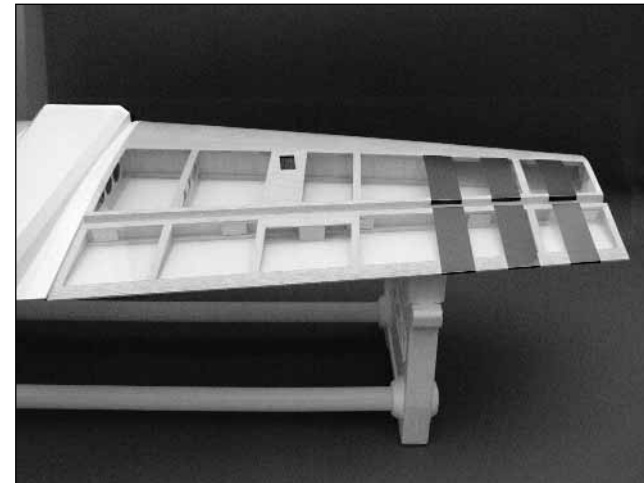

## Section 4: Installing the Ailerons

### □ □ Step 4

Use a ruler to align the end of the aileron to the wing. Also check the gap between the wing and aileron at the root, which should be about 1/32"–1/16".

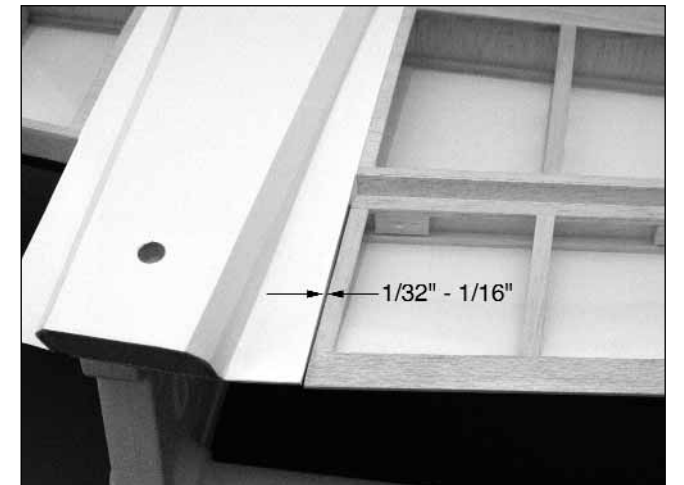
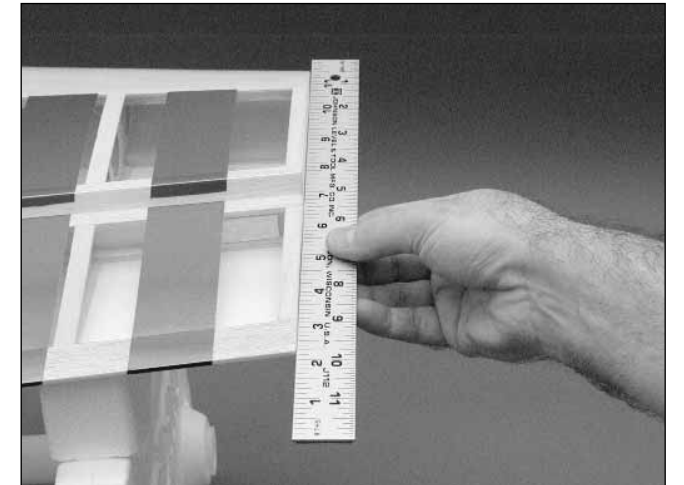

**Note:** Do not use CA accelerator during the hinging process. The CA must be allowed to soak into the hinge to provide the best bond. Using accelerator will not provide enough time for this process.

## Section 4: Installing the Ailerons

### □ □ Step 5

Remove the T-Pins and apply thin CA to each hinge. Make sure the hinge is fully saturated with CA. Use a paper towel and CA remover/debonder to clean up any excess CA from the wing and/or aileron.



### □ □ Step 6

Firmly grasp the wing and aileron and gently pull on the aileron to ensure the hinges are secure and cannot be pulled apart. Use caution when gripping the wing and aileron to avoid crushing the structure.

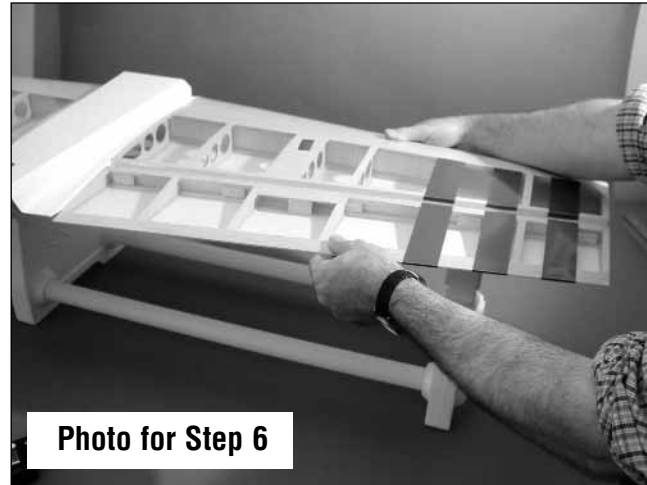

### □ □ Step 7

Move the aileron up and down several times to work in the hinges and check for proper movement.

### □ Step 8

Repeat Steps 1 through 7 for the remaining aileron.

## Section 5: Installing the Elevators

### Required Parts

- Fuselage assembly
- CA hinge (6)
- Elevator (left and right)

### Required Tools and Adhesives

- Thin CA
- T-Pins
- 30-minute epoxy
- Medium sandpaper

This step can be a little tricky, as the elevators must be installed parallel to each other. Grab a cappuccino and take your time to ensure this section goes as planned.

### □ □ Step 1

Locate three CA hinges and do the T-Pin thing to them.

### □ □ Step 2

Place the T-pins into one elevator half or stab half.

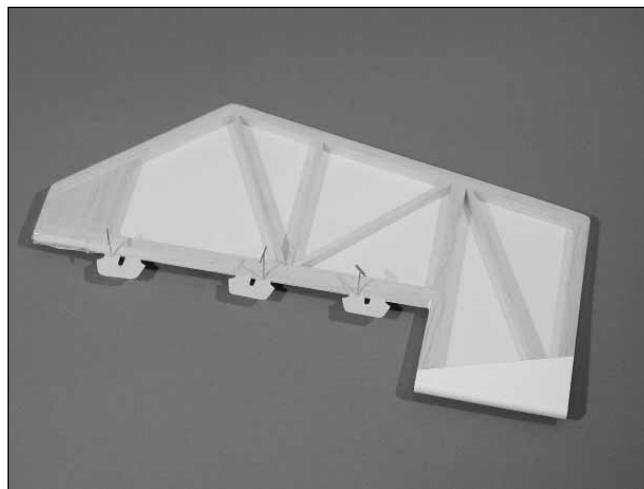

### □ □ Step 3

Slide the elevator and stab together. Remember to insert the joiner wire into the elevator before starting the hinges.

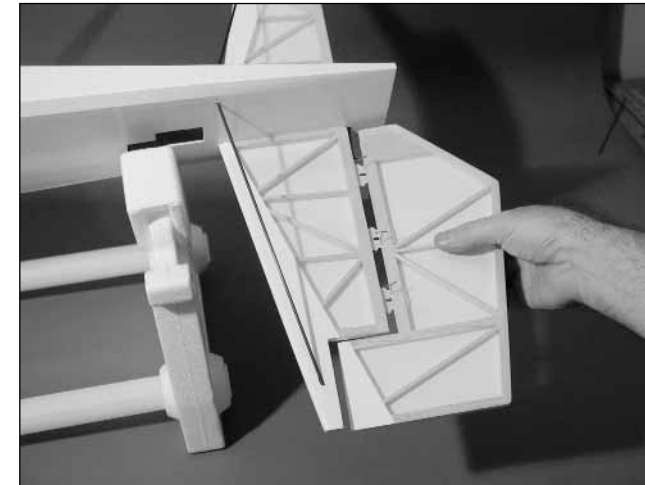

### □ Step 4

Repeat Steps 1 through 3 for the other elevator half.

### □ Step 5

Use a ruler to align one half of the elevator parallel to the stabilizer. Use a second ruler to see if the opposite elevator is also in alignment. If not, bend the joiner wire slightly until both elevators align. If the elevators are not aligned, the aircraft won't trim properly.

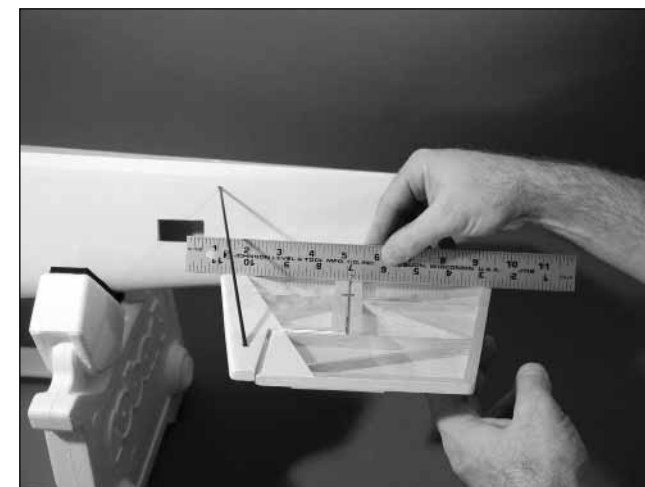

## Section 5: Installing the Elevators

### □ Step 6

Remove the elevators from the stabilizer. Roughen the joiner wire using medium sandpaper. Mix 1/2 ounce of 30-minute epoxy and apply it to the groove and hole in one elevator half. Install the elevator half as described in Step 3. Remove any excess epoxy using rubbing alcohol and a paper towel. 30-minute epoxy should provide enough time to do both of the elevators.

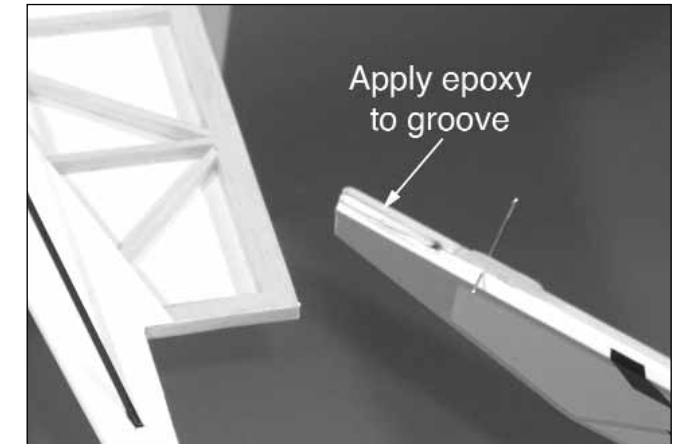

**Cool Tip:** You can combine the previous step with the following step if you like. This will hold the elevator in position while the epoxy cures.

### □ Step 7

Check to make sure both elevators move freely. They should not rub against the stabilizer towards the tips. Apply thin CA to both sides of the hinge. Make sure to saturate the hinge and don't use accelerator.

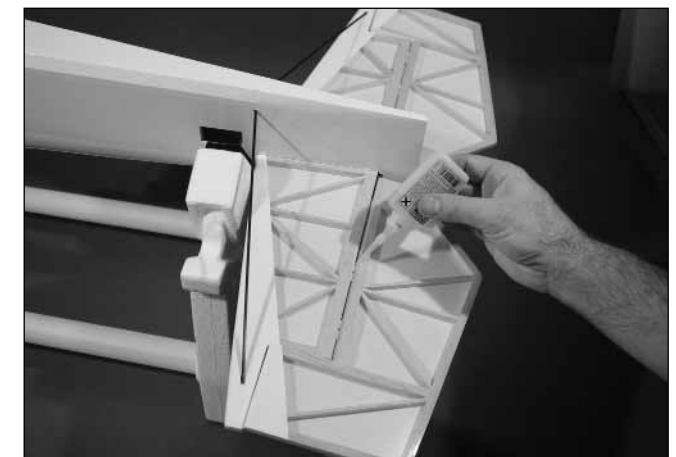



## Section 5: Installing the Elevators

### □ Step 8

Once the CA and epoxy has fully cured, give the elevator and stab the tug test to make sure the hinges are well glued. Flex the elevators a few times to break in the hinges.

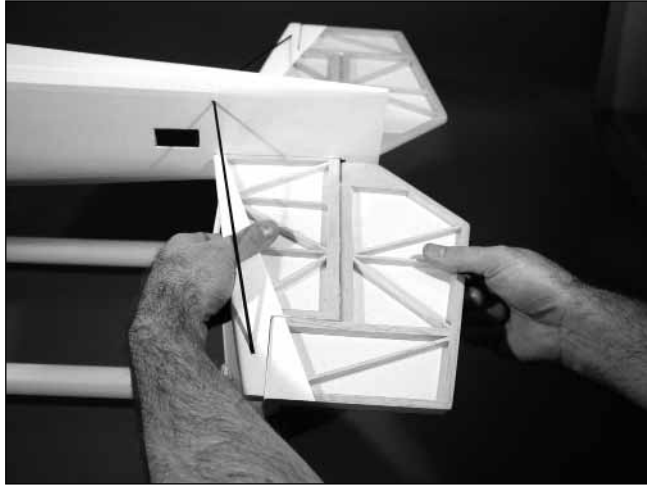

## Section 6: Installing the Tail Wheel

### Required Parts

- Fuselage assembly
- Rudder
- Tail wheel assembly

### Required Tools and Adhesives

- T-Pins
- Hobby knife
- 6-minute epoxy
- Petroleum jelly
- Drill
- Drill Bit: 1/8"
- Hex wrench (included in kit)

Although we both know this plane won't be on the ground much, it still needs to have a tail wheel to taxi back into the pits after your spectacular and thrilling aerobatic routine.

### □ Step 1

Locate the rudder and make a mark 1 1/4" from the bottom. Drill the location using a 1/8" drill bit. Make sure the drill is perpendicular to the hinge line of the rudder.

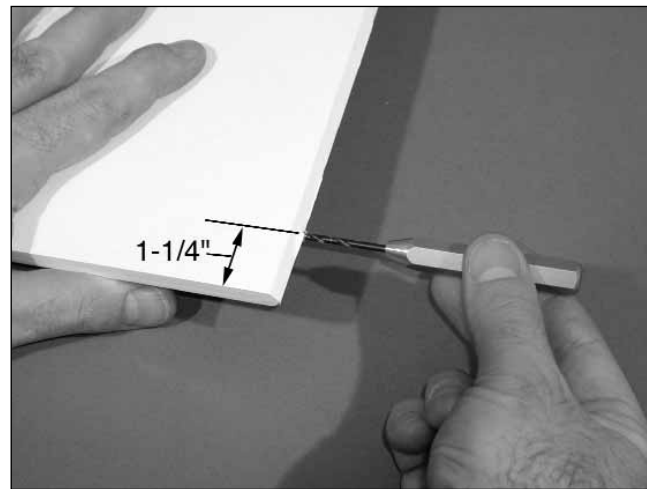

### □ Step 2

Cut a groove from the hole to the bottom of the rudder. This is necessary to provide clearance for the tail wheel bearing.

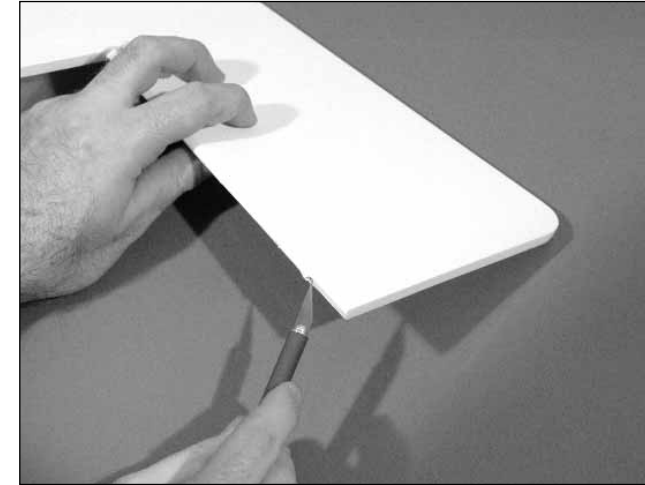

### □ Step 3

Test fit the tail wheel bracket into the rudder. Make sure there is plenty of clearance for the bracket bushing and that the hole has been drilled deep enough to fit the tail wheel wire.

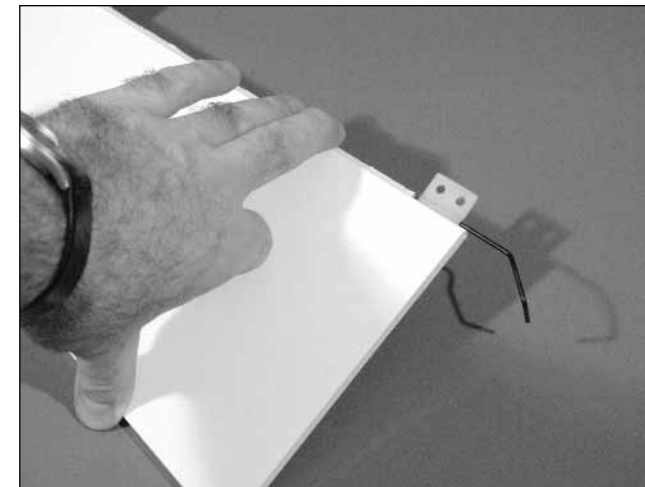

### □ Step 4

Cut a slot in the aft end of the fuselage for the tail wheel bearing using a hinging tool or hobby knife. Position the top of the slot 7/8" from the bottom of the fuselage. The slot should be 13/16" long, which is the length of the tail wheel bearing.

## Section 6: Installing the Tail Wheel

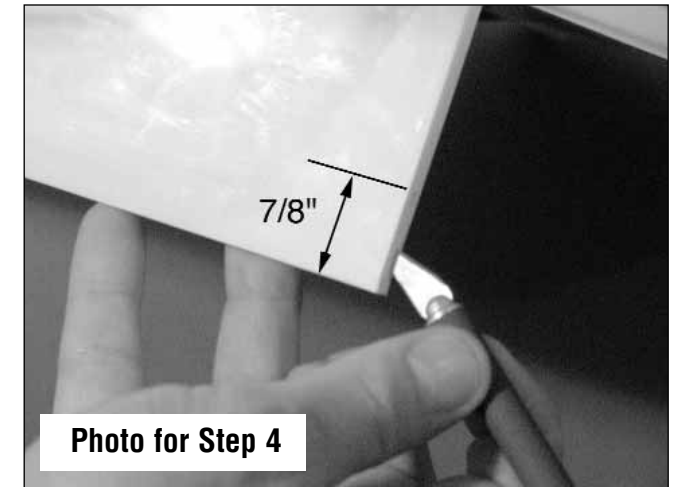

### □ Step 5

Test fit the tail wheel bearing into the slot. Make the slot large enough that the bushing will fit without forcing the wood apart.



### □ Step 6

Apply a light coat of petroleum jelly onto the tail gear wire where the bearing will ride. This is done to prevent the epoxy from sticking to the wire and bearing, which would make it a little difficult to steer or even use the rudder.

### □ Step 7

Mix 1/2 ounce of 6-minute epoxy and apply it to both the tail gear bearing and the slot in the fuselage. Install the bearing. Use a paper towel and rubbing alcohol to remove any excess epoxy from the tail gear wire, bushing, and fuselage.

## Section 7: Installing the Rudder

### Required Parts

- Fuselage assembly
- Rudder
- CA hinge (3)

### Required Tools and Adhesives

- Thin CA
- T-Pins
- 6-minute epoxy

The last and most powerful of the control surfaces to install, the rudder. Just think, from here on out, all you need to do is install the radio, engine, fuel tank... Well, I guess there is still quite a bit more to do.

#### Step 1

Locate the last three CA hinges, and place T-pins in the center like we have done for the ailerons and elevator.

#### Step 2

Install the hinges in the rudder.



#### Step 3

Place the rudder in its location on the fuselage. You may notice that there isn't a slot cut into the fuselage for the bottom hinge. Use a felt-tipped marker to indicate the location for the hinge.

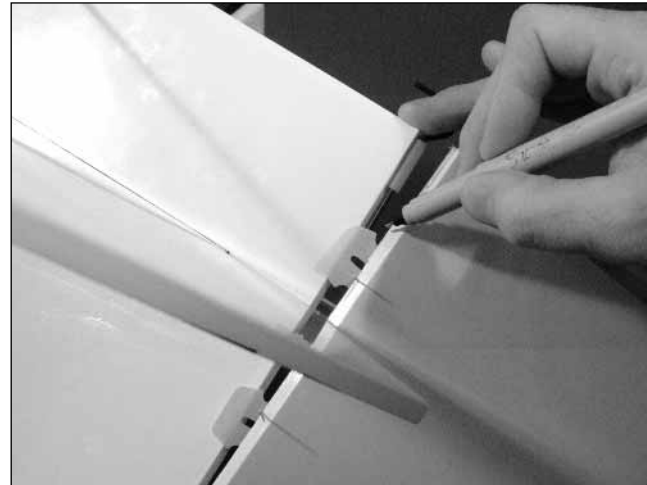

#### Step 4

Cut a slot in the fuselage for the lower hinge. Use a hinging tool, or carefully use a hobby knife.

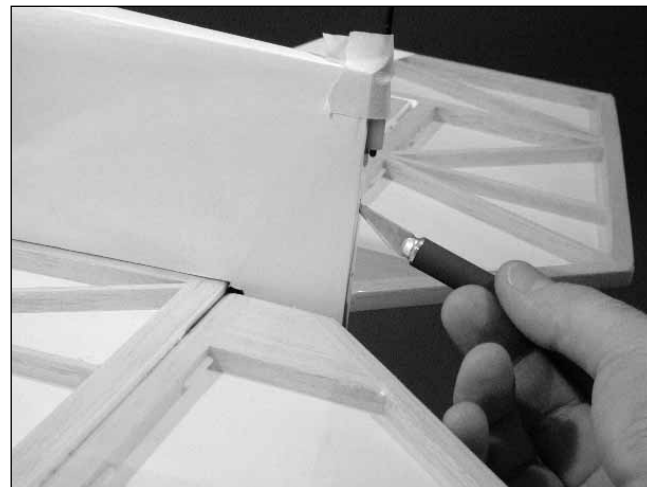

#### Step 5

Test fit the rudder to the fuselage. Make sure the tail gear wire goes into the rudder, and that the rudder will rest tight against the fin and fuselage. The tail gear bearing should not interfere with the rudder. If it does, fix it.

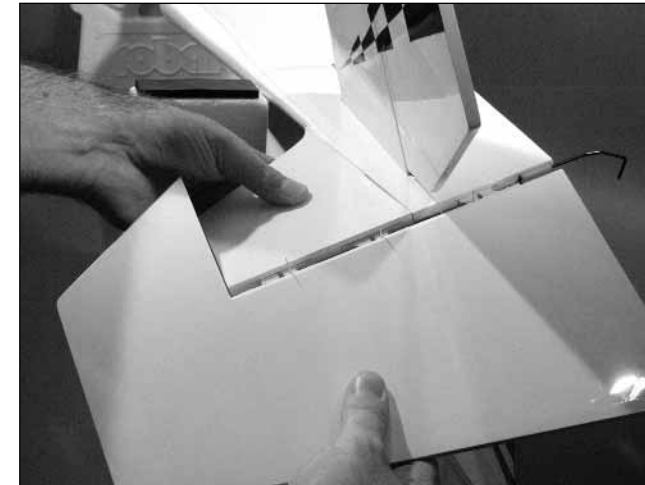

#### Step 6

Mix 1/2 ounce of 6-minute epoxy. Remove the rudder and place the epoxy only in the hole, not in the groove. Epoxy in the groove will probably make it difficult to use the rudder. Install the rudder as described in the previous step.

**Cool Tip:** You can combine the previous step with the following step if you like. This will hold the rudder in position while the epoxy cures.

#### Step 7

Check to make sure the rudder moves freely. It should not rub against the fin at the tip. Apply thin CA to both sides of the hinge. Make sure to saturate the hinge, and don't use accelerator. Use a paper towel and CA debonder/remover to clean up any excess CA.

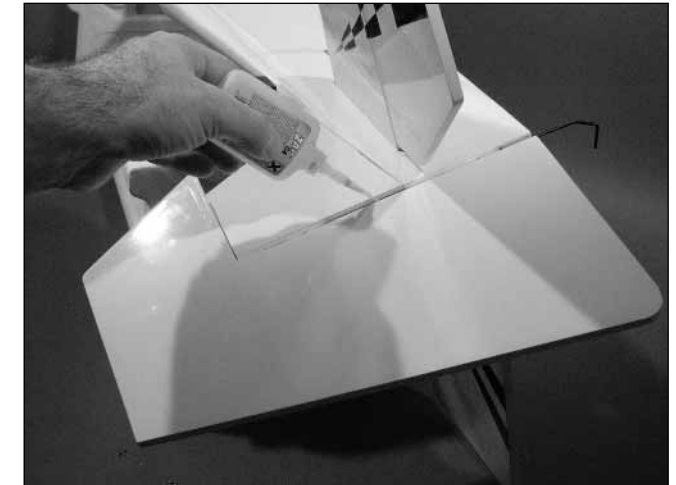

#### Step 8

Once the CA and epoxy has fully cured, give the rudder and fin the tug test to make sure the hinges are well glued. Flex the rudder a few times to break in the hinges.

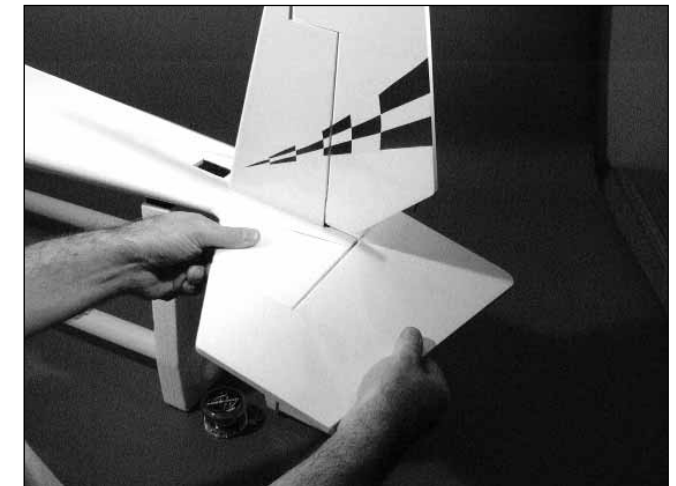

## Section 8: Engine Installation

### Required Parts

- Fuselage assembly
- Engine mount (2)
- 6-32 x 3/4" screw (4)
- #6 x 5/8" socket head sheet metal screw (4)

### Required Tools and Adhesives

- Drill
- Pliers
- Engine
- Phillips screwdriver (large)
- Drill Bit: 3/32"
- Clamp

The FuntanaS™ makes a great plane for electric conversion. The airframe is very light and there is plenty of room inside of the fuselage to install batteries, since the servos are in the wings and tail. It sure would be a nice change, and you could prove that electrics are just as cool as glow planes. If you have decided to make the conversion, skip directly to Section 12, Electric Motor Installation.

#### Step 1

Attach the engine mount to the firewall using four 6-32 x 3/4" screws.



#### Step 2

Position the engine on the mount. Adjust the engine so the distance from the firewall to the drive washer is 4 3/8". Use a clamp to hold the engine in position.

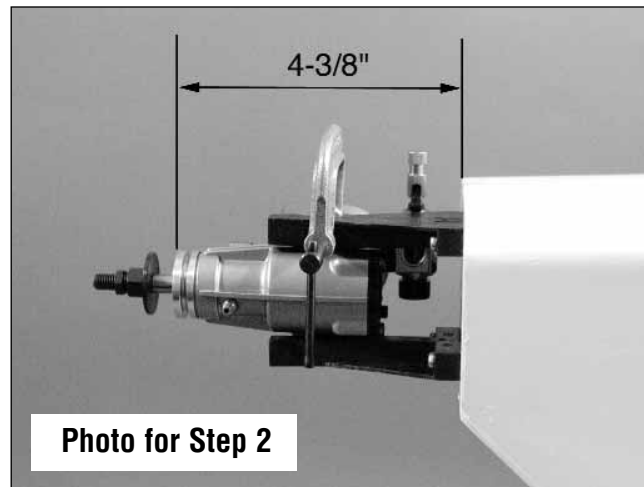

#### Step 3

Mark the locations for the engine mounting bolts.

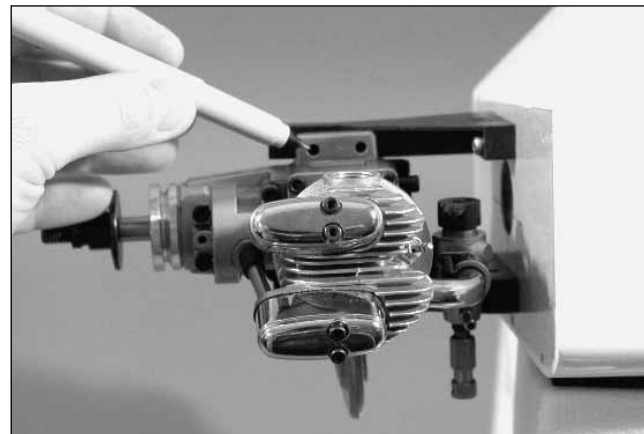

#### Step 4

Remove the engine and drill the locations marked in the previous step using a 3/32" drill bit.



## Section 8: Engine Installation

**Cool Tip:** Apply a little bar soap to the threads of the screws to make them thread easier into the mount. You can also remove the mounts and run the screws through, then reattach them to the firewall, then bolt the engine down.

**Cool Tip:** Use a drill press for the best results. This makes holes perfectly perpendicular (square) to the mount.

#### Step 5

Attach the engine using four #6 x 5/8" socket head sheet metal screws.



## Section 9: Throttle Pushrod Installation

### Required Parts

- Fuselage assembly
- 16 1/2" outer pushrod tube

### Required Tools and Adhesives

- Drill
- Drill Bit: 5/16"
- Medium CA
- Sandpaper

This section is obviously for those guys that decided on installing a glow engine. If you have opted to go electric, you can skip this section, and the next section, and even the one after that.

#### Step 1

Determine the proper location for the throttle pushrod. Mark the location with a felt-tipped pen and drill the firewall for the pushrod tube using a drill and 5/16" drill bit. Remove the engine if necessary.



## Section 9: Throttle Pushrod Installation

### □ Step 2

Test fit the throttle pushrod tube through the firewall and into the fuselage. Once satisfied with the fit, roughen the tube using medium sandpaper. Slide the tube back into position and use medium CA to glue it to the firewall.

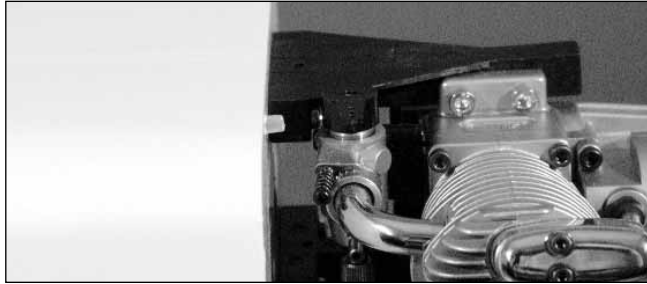

### □ Step 3

Trim the throttle pushrod tube so it extends 1" onto the servo tray.

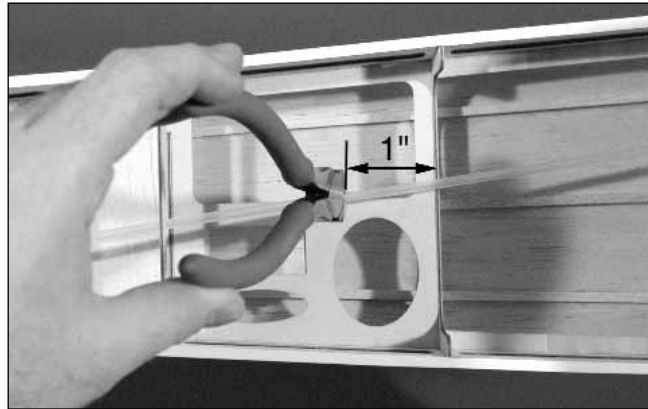

## Section 10: Fuel Tank Assembly

### Required Parts

- Clunk (fuel pickup)
- Fuel pickup tubing
- Rubber stopper
- Metal tubes (short and long)
- Metal caps (2)
- Fuel tank
- M3x20 screw

### Required Tools and Adhesives

- Hobby knife
- Phillips screwdriver (small)

**Note:** The stopper provided with the FuntanaS™ has three holes that are not bored completely through the stopper. The holes are for the fuel pickup, fill, and vent lines. For these instructions only two holes will be used: one for the fuel pickup and one for the fuel vent. Only open the third hole if you are going to use a separate fill line.

### □ Step 1

Locate the fuel tank parts.

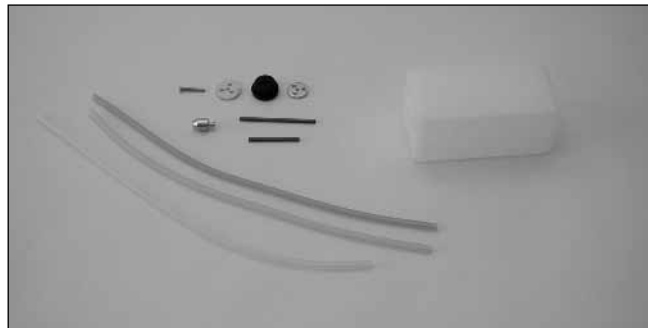

### □ Step 2

Locate the rubber stopper. Insert the shorter metal fuel tube into one of the holes in the stopper so that an equal amount of tube extends from each side of the stopper. This tube will be the fuel tank pickup that provides fuel to the engine.



### □ Step 3

Slide the smaller cap over the tube on the smaller end of the rubber stopper. This end will be inserted into the fuel tank. The larger cap is placed on the side of the rubber stopper that makes the cap. Loosely install the M3 x 20 screw through the center of the stopper.



### □ Step 4

Bend the longer fuel tube carefully to a 45 degree angle using your fingers. This will be the fuel tank vent tube. Use care not to kink the tube while bending.

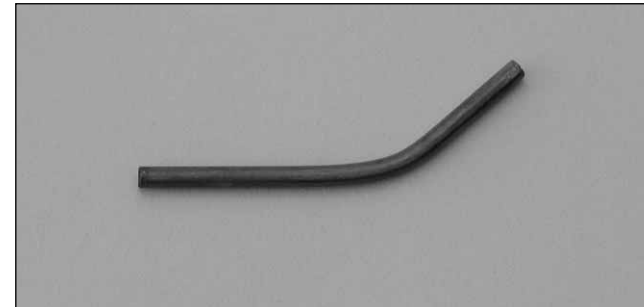

### □ Step 5

Slide the vent tube into one of the remaining two holes in the stopper from the tank (small cap) side.



## Section 10: Fuel Tank Assembly

### □ Step 6

Locate the short piece of silicone fuel tubing and the fuel tank clunk. Install the clunk onto one end of the silicone tubing. Slide the silicone tubing (end opposite the clunk) onto the fuel tank pickup tube (straight tube) in the stopper.

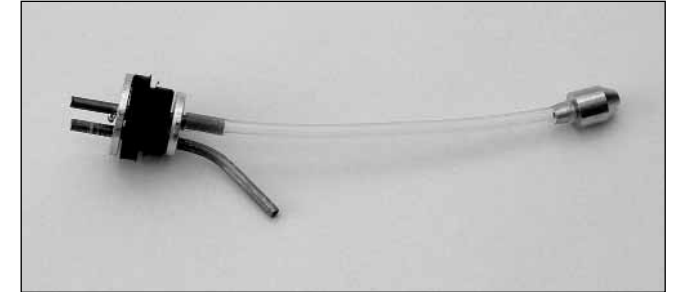

### □ Step 7

Carefully insert the stopper assembly into the fuel tank. Note the position of the vent tube; it must be up at the top portion of the fuel tank to function properly. Also, it may be necessary to shorten the length of the fuel pickup tubing to make sure the clunk does not rub against the back of the fuel tank. You should be able to turn the tank to any attitude except for having the stopper facing downward the clunk will fall to the lowest point.

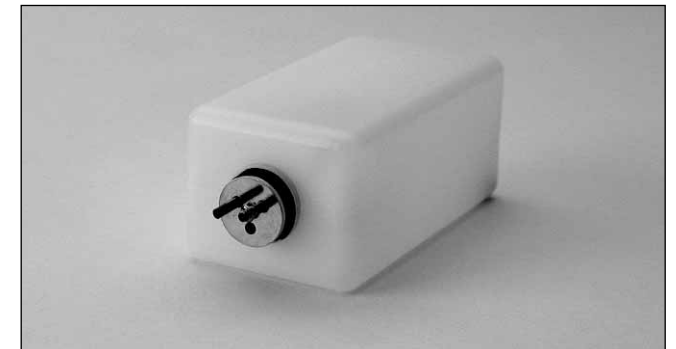

## Section 10: Fuel Tank Assembly

### Step 8

Tighten the M3 x 20 screw carefully—do not over tighten. This allows the rubber stopper to form a seal by being slightly compressed, thus sealing the fuel tank opening.

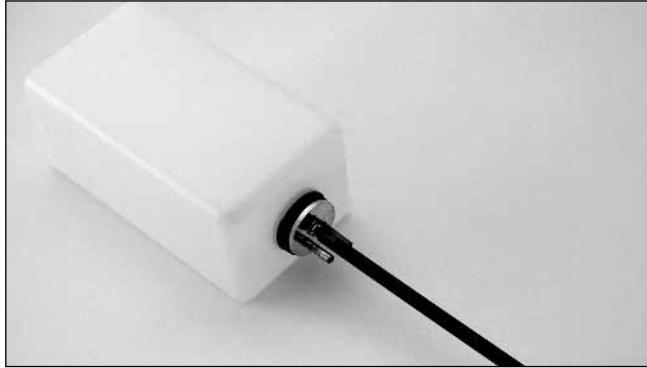

**Important:** Be sure to differentiate between the vent and fuel pickup tube. Once the tank is mounted inside the fuselage, it will be difficult to tell the tubes apart.

## Section 11: Fuel Tank Installation

### Required Parts

- Fuselage assembly
- Fuel tank assembly
- Fuel tubing (red and green)

### Required Tools and Adhesives

- Foam: 1/4", 1/2"
- Masking tape

When installing the fuel tank, make sure to have a piece of foam at any point that contacts any structure inside the fuselage. Without the foam, vibrations will be transmitted to the fuel tank, which will cause the fuel to foam. In turn, you will not get the optimum performance from your engine.

### Step 1

Glue a piece of 1/2" foam and 1/4" foam inside the fuselage as shown.



### Step 2

Connect the two pieces of fuel tubing to the fuel tanks pickup and vent tubes.

**Cool Tip:** Connect the red tube to the vent, and the green tube to the pickup. If you forget, just come back to this paragraph to remind yourself.

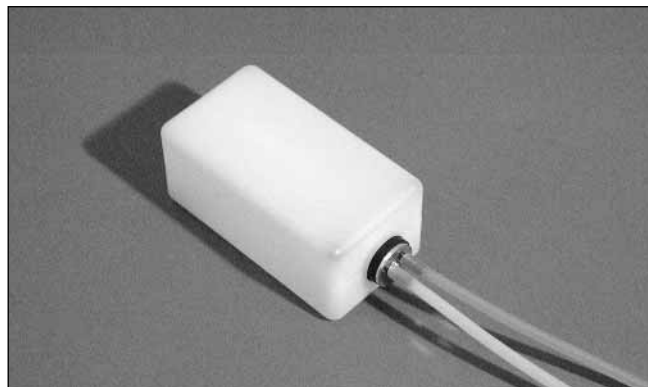

## Section 11: Fuel Tank Installation

**Cool Tip:** Make sure the rear support brace will not interfere with the installation of the wing.

### Step 4

Make the proper connections to the engine using the engine manufacturer's instructions.

### Step 3

Install the fuel tank into the fuselage. Make any necessary supports to keep the tank from moving during flight.

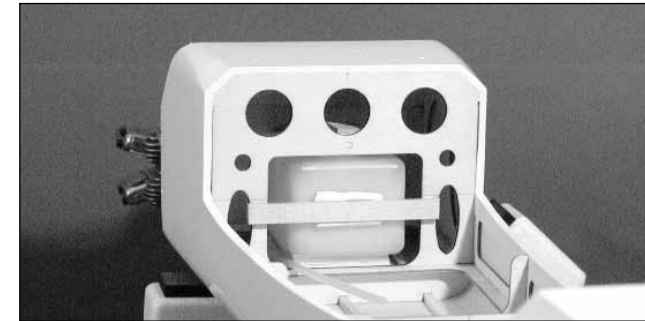

## Section 12: Electric Motor Installation

### Required Parts

- Fuselage assembly

### Required Tools and Adhesives

- 6-32 all thread (4)
- 6-32 nuts (20)
- 1/8" Aircraft ply (2 PCS)
- Hook and loop material
- Hacker B50-10L motor with 6.7:1 gearbox
- APC 17 x 10 electric prop
- Batteries: • 16-cell Sanyo HRSC2600 Ni-MH or  
• 4 parallel 5 cell packs in series (Li Poly 8000mAh cells)

### Step 1

Cut 2-ply pieces as shown in the photos. Drill both pieces to match 4 mounting holes in firewall. Cut a clearance hole for the motor in one, and mount the motor to the other.

### Step 2

Install a piece of 6-32 all thread into each blind nut in the firewall. Use a 6-32 nut to lock the threaded rod into position.

### Step 3

Thread a 6-32 nut onto each of the threaded rods about 2/3 of the way toward the firewall. Slide the ply plate with the clearance hole onto the rods. Use four more nuts to secure the plate in position.

### Step 4

Place four more nuts on the front of the all thread, install the motor and plate and secure with four nuts. Use threadlock to keep the nuts from loosening during flight.

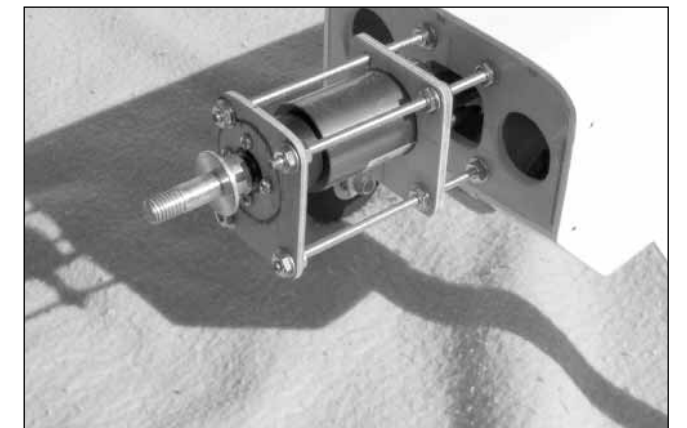

## Section 12: Electric Motor Installation

### Step 5

Install the batteries as shown. Use hook and loop material to keep the batteries from moving during flight.



## Section 13: Cowling Installation

### Required Parts

- Fuselage assembly
- Cowling
- #2 x 1/2" sheet metal screw (4)

### Required Tools and Adhesives

- Drill
- Drill Bit: 3/32", 1/8"
- Phillips screwdriver (small)

### Step 1

Use a piece of cardstock to indicate the location of the engine and firewall.

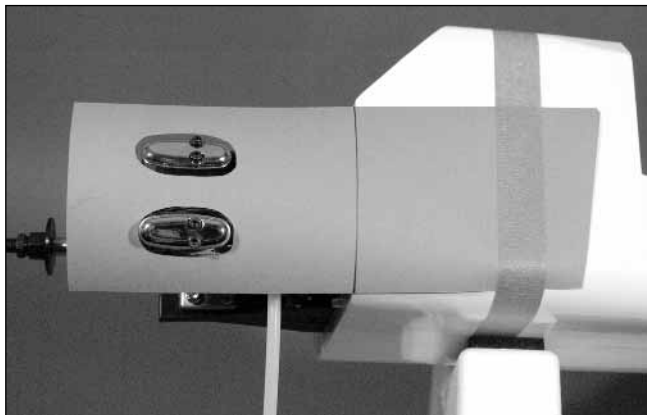

### Step 2

Remove the engine. Position the cowl onto the fuselage so it is 4 1/4" from the firewall. Transfer the location for only the engine onto the cowl.

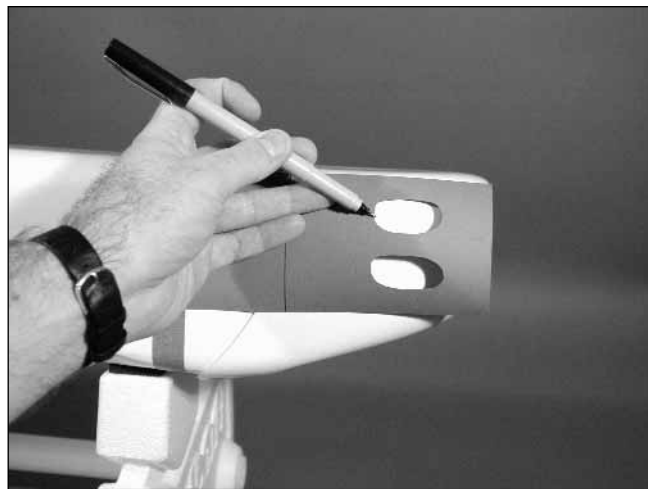

### Step 3

Remove the cowl and remove the necessary material to fit the cowl over the engine. Install the engine back onto the firewall, and test fit the cowl over the engine.

**Cool Tip:** Start by removing only a little material at a time. You can always make the holes bigger, but you can't make them smaller. Work until the cowl fits nicely over the engine.

### Step 4

Slide the cowling onto the fuselage. Temporarily install the propeller and spinner back plate. Position the cowl so there is 1/8" gap between the back plate and the cowl.

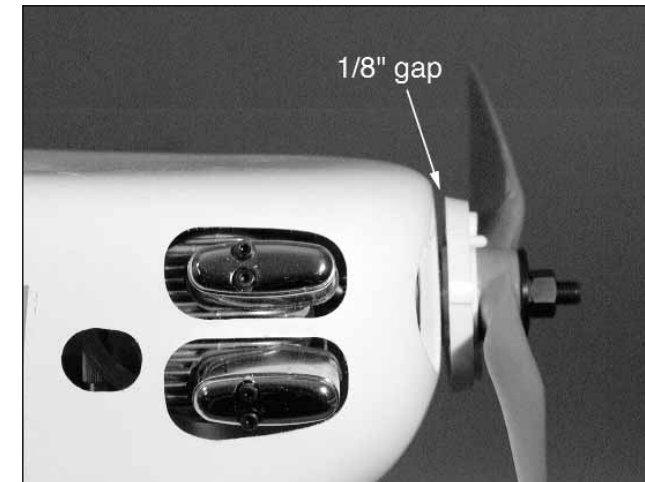

### Step 5

Use the cardstock from Step 1 to locate the positions for the cowling screws. The goal is to drill into the firewall for the four screws that hold the cowling. Drill the locations using a 3/32" drill bit.



## Section 13: Cowling Installation

### Step 6

Enlarge the holes drilled in the cowling using a 1/8" drill bit.

### Step 7

Make any cut outs in the cowling to clear items such as the muffler, fueling valve, needle valve, etc.

### Step 8

Attach the cowl using four #2 x 1/2" sheet metal screws.



### Step 9

Apply a couple drops of CA into the screw holes after threading the screws in a couple times. This will harden the wood and keep the screws from loosening during flight.

# Section 14: Landing Gear Installation

## Required Parts

- Landing gear
- 1" tail wheel
- 2 1/4" wheel (2)
- 4-40 blind nut (2)
- Fuselage assembly
- 6-32 x 1/2" screw (2)
- Wheel pant (left and right)
- 5/32" x 1 1/8" axle w/nut (2)
- 1/16" wheel collar w/set screw
- 4-40 x 1/2" socket head screw (2)
- 5/32" wheel collar w/set screw (4)

## Required Tools and Adhesives

- Drill
- Drill Bit: 1/16", 1/8", 5/32"
- Phillips screwdriver (large)
- Hex wrench (included in kit)

### Step 1

Locate the main landing gear and two 6-32 x 1/2" screws. Attach the gear using the screws. The angle on the gear should be towards the rear of the plane.

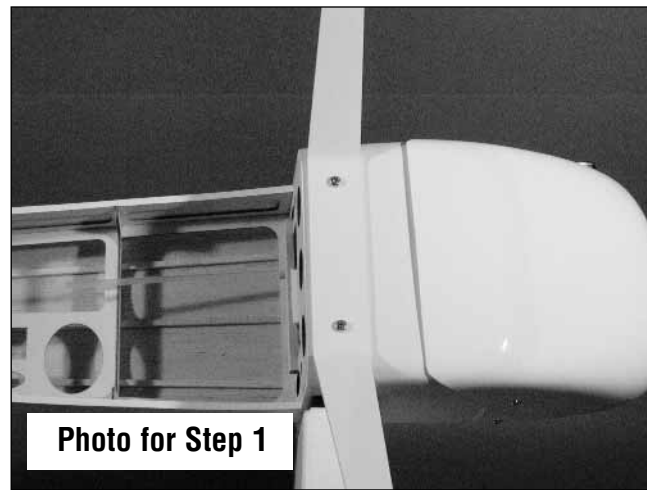
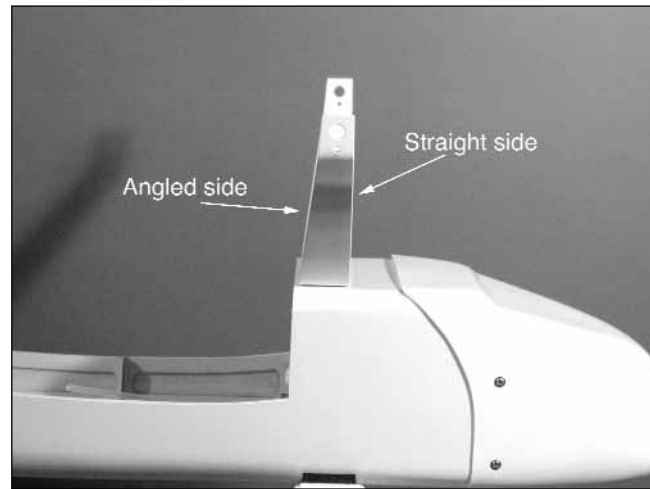

### Step 2

Attach an axle to the landing gear using a nut.

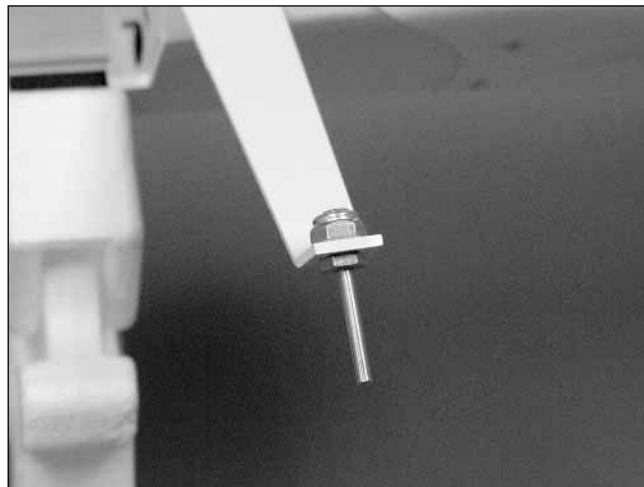

### Step 3

Hold the wheel pant so it is parallel to the bottom of the fuselage. Mark the location for the wheel pant screw.

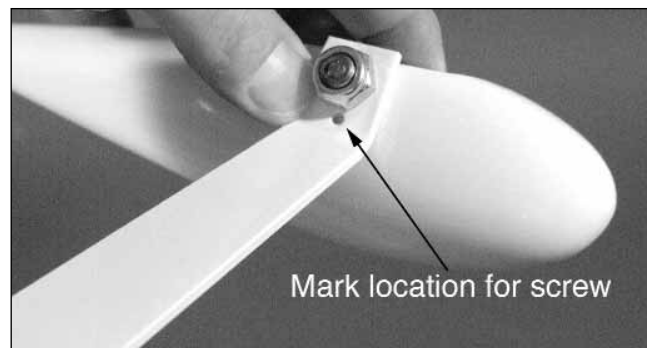

### Step 4

Drill the location for the pant screw using a 5/32" drill bit.

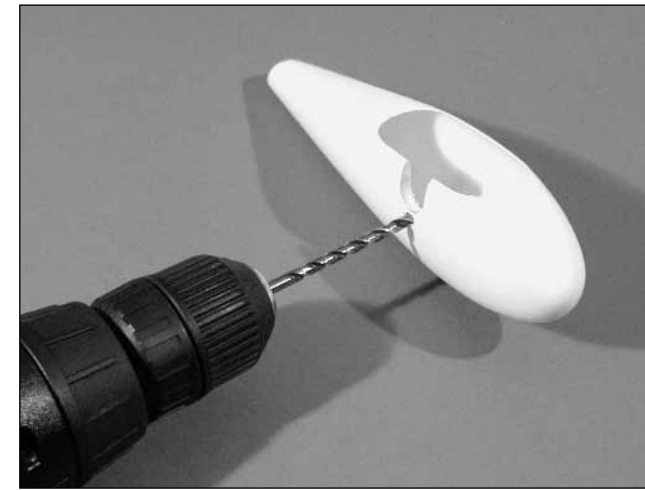

### Step 6

Insert a 4-40 blind nut into the hole from the inside of the wheel pant.

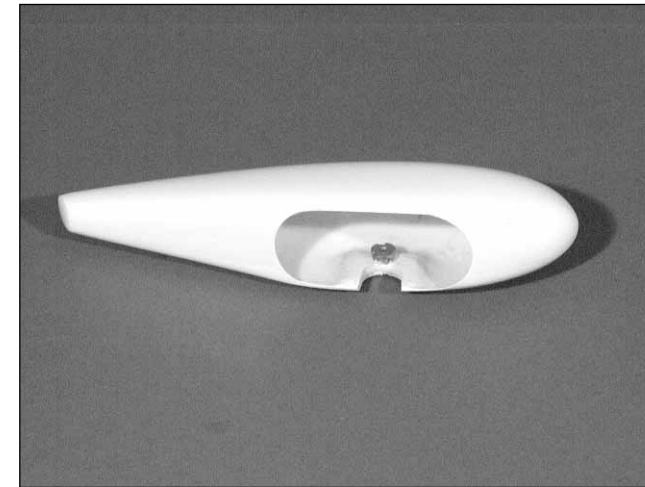

# Section 14: Landing Gear Installation

### Step 7

Attach the wheel to the axle using two wheel collars and set screws. The exact position of the wheel will be determined after the wheel pant is installed.



**Cool Tip:** Position the set screws on the wheel collars facing directly down. This way you can get to them later to position the wheel on the axle.

### Step 8

Attach the wheel pant to the landing gear using a 4-40 x 1/2" socket head screw.



## Section 14: Landing Gear Installation

### Step 9

Position the wheel so it is centered in the wheel pant. Tighten the collars once the wheel has been positioned.



### Step 10

Repeat Steps 2 through 9 for the other wheel pant.

### Step 11

Attach the tail wheel using a 5/32" wheel collar.



### Required Parts

## Section 15: Radio Installation

- Fuselage assembly
- Wing assembly
- Servo w/hardware (5)

### Required Tools and Adhesives

- Drill
- Drill Bit: 1/16", 3/32"
- Phillips screwdriver (small)

### Step 1

Install the recommended servo hardware (grommets and eyelets) supplied with your radio system onto five servos (elevator, rudder, throttle, and aileron (2)).

### Step 2

Temporarily install the rudder servo.



### Step 3

Mark the locations for the servo screws using a felt-tipped pen.

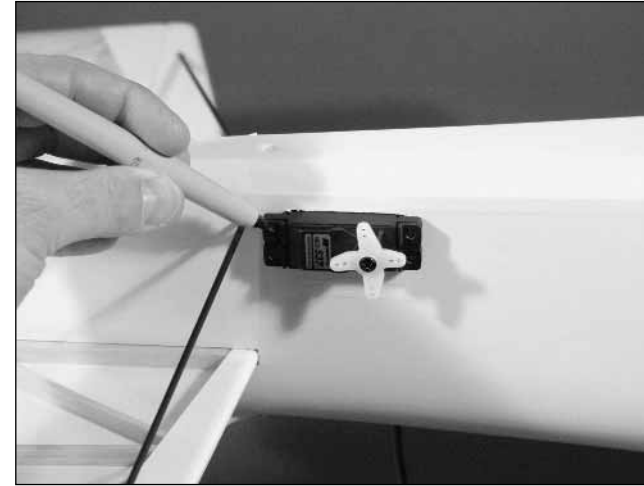

### Step 4

Remove the servo and drill the holes for the servo mounting screws using a 1/16" drill bit.

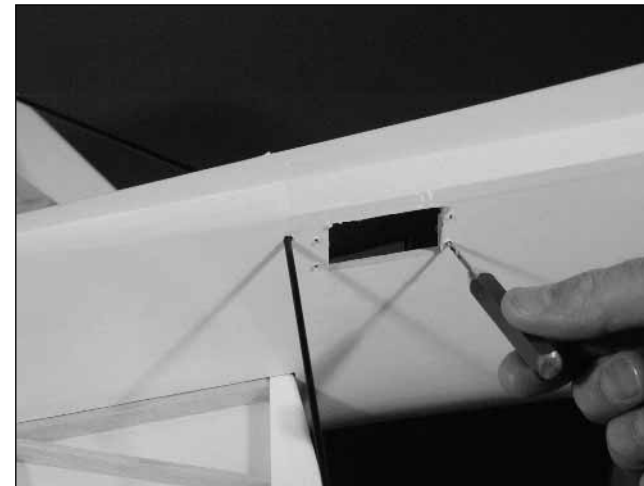

**Cool Tip:** Place a drop of thin CA onto each screw hole to harden the wood around the

## Section 15: Radio Installation

hole. Allow the CA to fully cure before installing the servos.

### Step 5

Attach an 18" servo extension onto the rudder servo. Use your favorite method to secure the extension to prevent it from coming loose during flight. Secure the rudder servo using the screws provided with the servo.

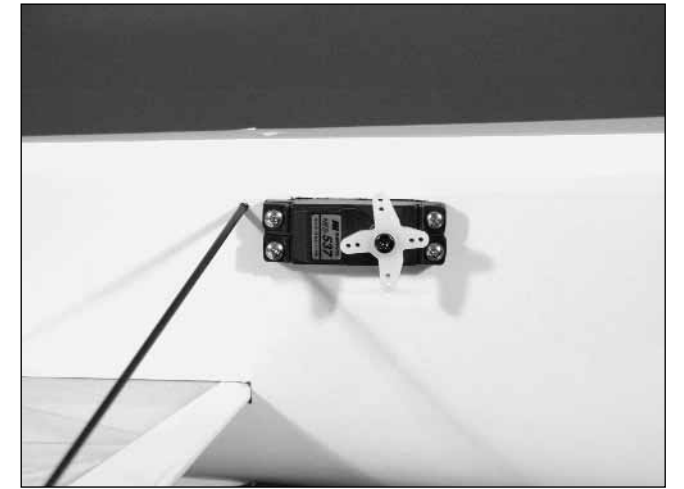

### Step 6

Repeat Steps 1 through 5 for the elevator servo.



### Step 7



## Section 15: Radio Installation

Temporarily install the aileron servo and mark the locations for the servo screws using a felt-tipped pen.

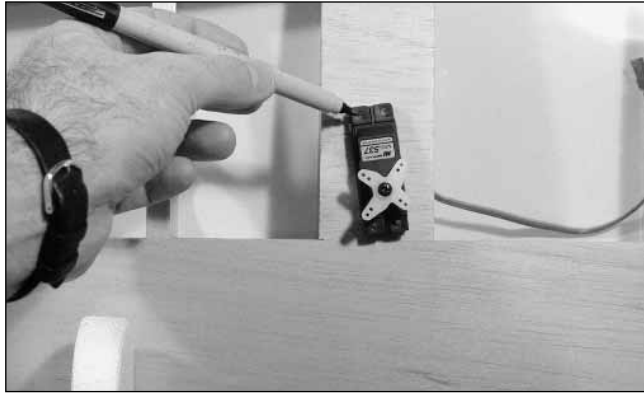

### Step 8

Remove the servos and drill the holes for the servo mounting screws using a 1/16" drill bit.

### Step 9

Use a piece of string with a small weight (such as a wheel collar) attached as a device to pull the servo lead through the wing. Lower the weight through the servo opening, allowing it to pass through the ribs and out the hole in the center of the wing.

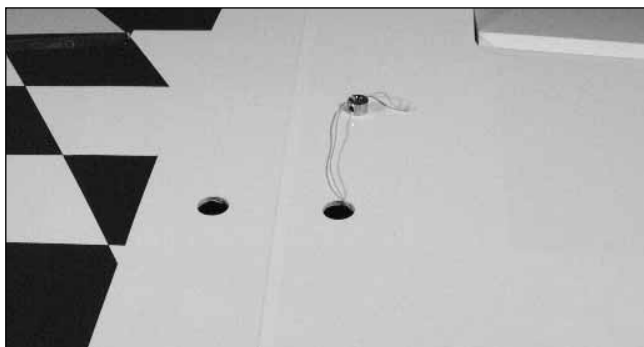
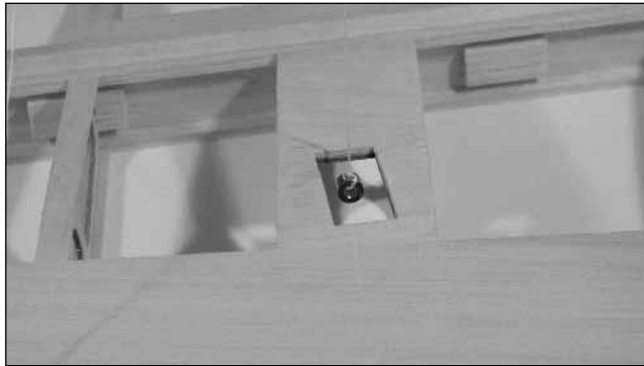

### Step 10

Attach a 9" servo extension to the aileron servo. Tie the string onto the servo extension. Gently pull the extension through the wing using the string. Untie the string when the servo lead has been pulled through. Use tape to secure the servo lead to the wing to prevent it from falling back into the wing panel.



### Step 11

Repeat Steps 7 through 10 for the other aileron servo.

### Step 12

Temporarily install the throttle servo and mark the locations for the servo screws using a felt-tipped pen. Remove the servo and drill the holes for the servo mounting screws using a 1/16" drill bit. Secure the servo using the screws supplied with the servo.

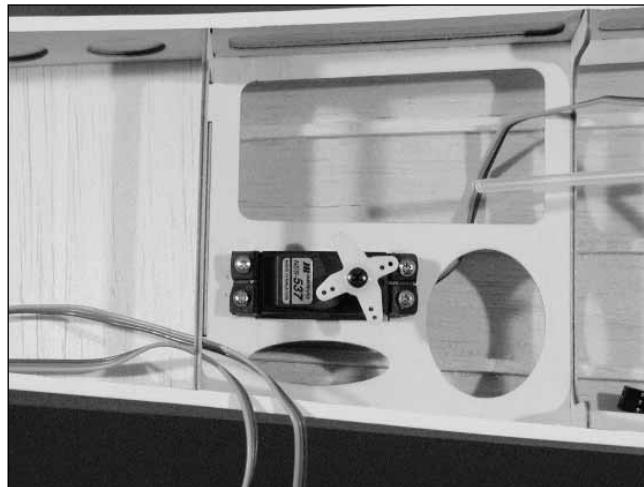

### Step 13

Wrap the receiver and receiver battery in protective foam to prevent damage that may be caused by engine vibration.

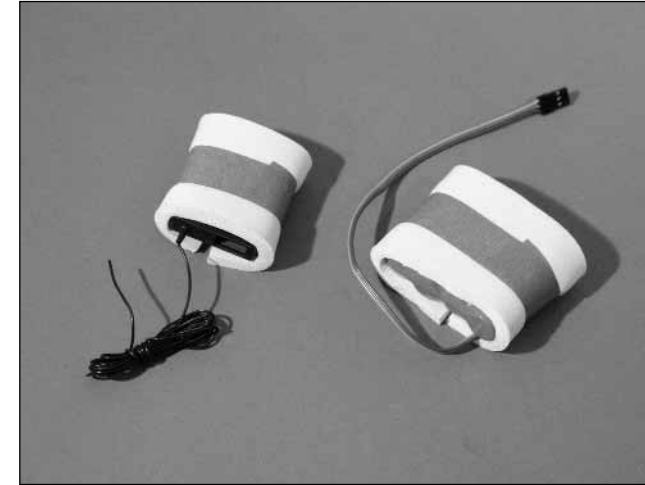

### Step 14

Temporarily mount the receiver and battery into the fuselage. It may be necessary to relocate the battery forward or aft to balance the model as described in the section "Control Throws and Center of Gravity." Plug in any servo leads or extensions at this time.

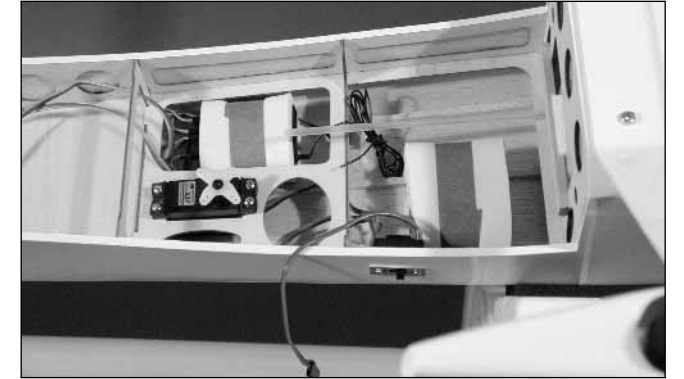

### Step 15

Mount the radio switch in the side of the fuselage.

### Step 16

Route the antenna out through the bottom of the fuselage and secure it to the tail wheel with rubber bands.

# Section 16: Linkage Installation

## Required Parts

- Wing assembly
- Clevis retainer (5)
- Nylon wire keeper (5)
- 2-56 x 1/2" screw (6)
- 7 7/8" pushrod wire (5)
- 7 7/8" pushrod wire (4)
- #2 x 3/4" sheet metal screw (6)
- Nylon clevis (5)
- Fuselage assembly
- 18 3/4" pushrod wire
- Nylon control horn (4)

## Required Tools and Adhesives

- Drill
- Drill Bit: 1/16", 3/32"
- Phillips screwdriver (small)

### □ □ Step 1

Slide a clevis retainer onto a nylon clevis. Thread a clevis onto a 7 7/8" wire a minimum of 10 turns.

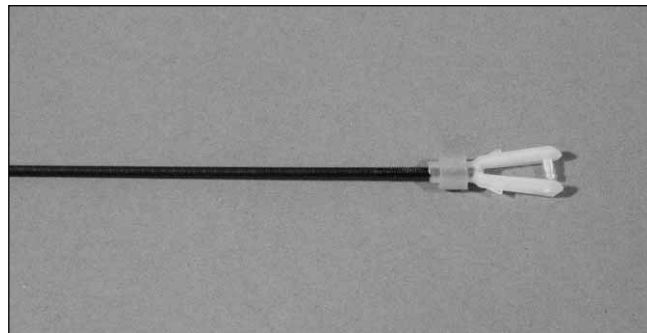

### □ □ Step 2

Remove the back plate from a control horn using side cutters or a sharp hobby knife.

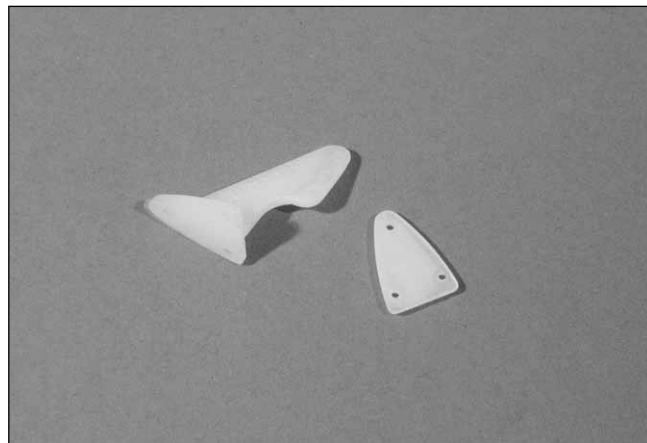

### □ □ Step 3

Position the control horn on the elevator so the horn aligns with the hinge line of the elevator. Mark the position for the mounting holes using a felt-tipped pen.

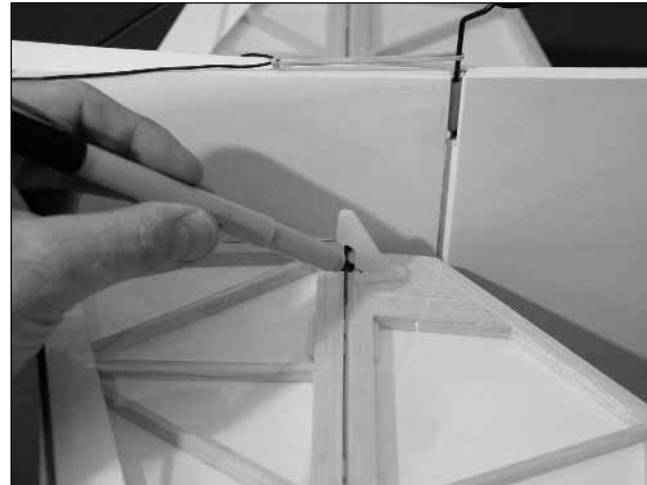

### □ □ Step 4

Drill three 3/32" holes through the elevator at the locations marked in the previous step.



### □ □ Step 5

Place 2-3 drops of thin CA into the hole to harden the wood. Repeat this for each of the three holes.



### □ □ Step 6

Attach the control horn using three 2-56 x 1/2" screws and the control back plate.

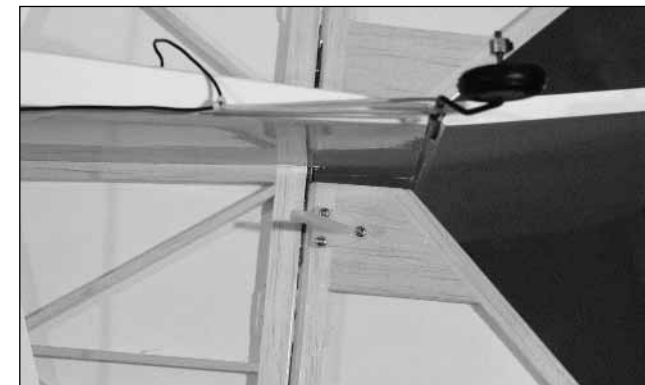

# Section 16: Linkage Installation

### □ □ Step 7

Center the elevator servo electronically using the radio system. Install a servo arm onto the elevator servo. Attach the pushrod with clevis to the control horn. Physically place the elevator control surface in neutral. Mark the pushrod where it crosses the holes in the servo arm.

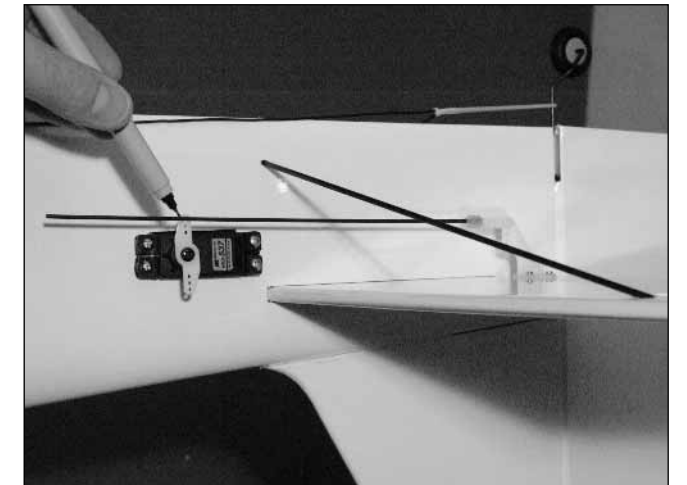

### □ □ Step 8

Bend the wire 90 degrees at the mark made in the previous step.

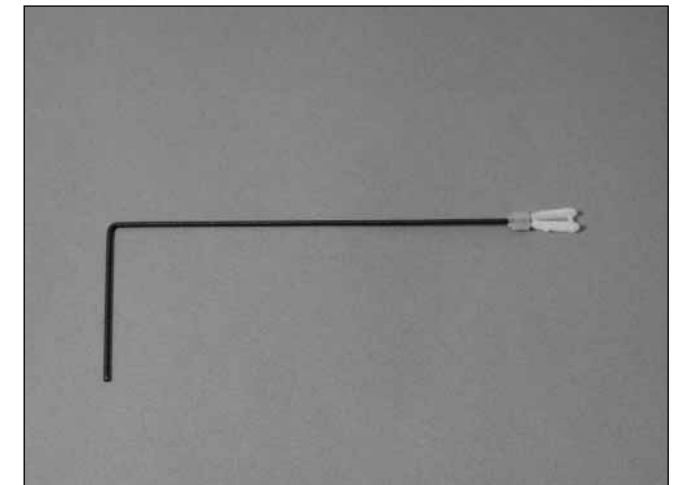

## Section 16: Linkage Installation

### □ □ Step 9

Cut the wire 1/2" above the bend.

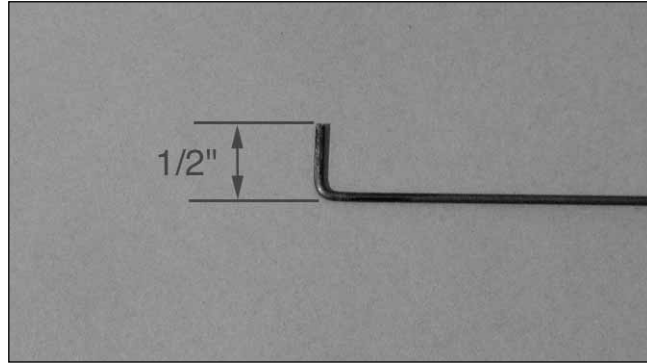

### □ □ Step 10

Slide the wire through the outer hole in the elevator servo arm. Secure the wire using a nylon wire keeper.



### □ Step 11

Repeat Steps 1 through 10 for the rudder linkage.

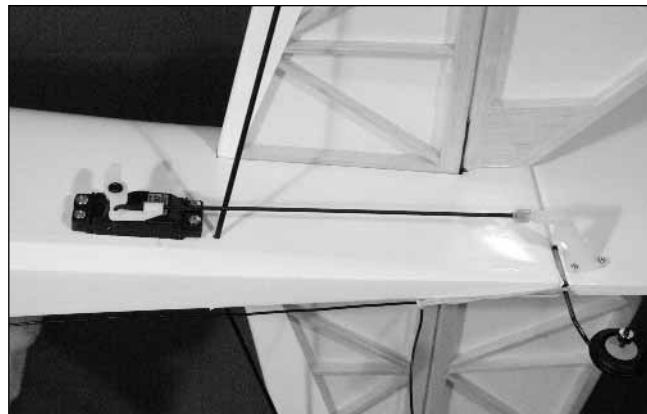

### □ □ Step 12

Slide a clevis retainer onto a nylon clevis. Thread a clevis onto a 7-7/8" wire a minimum of 10 turns.

### □ □ Step 13

Remove the back plate from a control horn using side cutters or a sharp hobby knife.

### □ □ Step 14

Position the control horn on the aileron so the horn aligns with the hinge line of the aileron. Mark the position for the mounting holes using a felt-tipped pen.

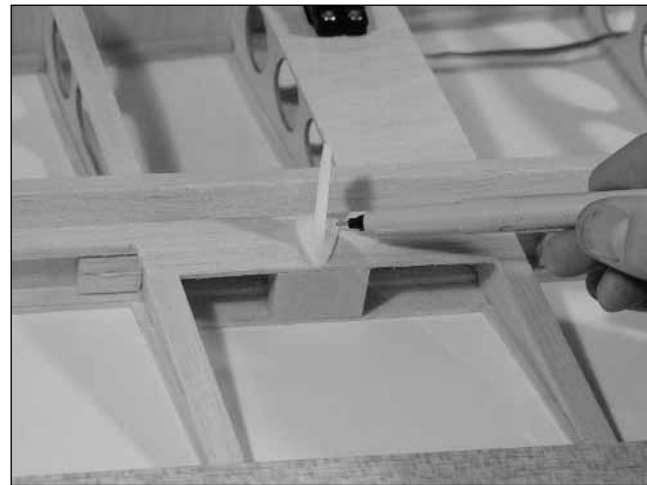

### □ □ Step 15

Drill three 1/16" holes at the locations marked in the previous step. The holes only need to be 3/4" deep: don't drill through the top of the aileron.

### □ Step □ 16

Install one of the #2 x 3/4" screws in a hole drilled, then remove it. Place 2-3 drops of thin CA into the hole to harden the wood. This will eliminate the potential of the screw pulling out of the wood. Repeat this for each of the three holes.

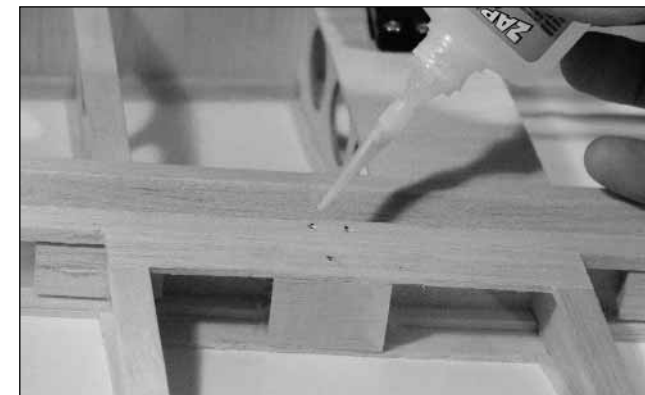

### □ □ Step 17

Attach the control horn using three #2 x 3/4" screws.



### □ □ Step 18

Center the aileron servo electronically using the radio system. Install a servo arm onto the aileron servo. Attach the pushrod with clevis to the control horn. Physically place the aileron control surface in neutral. Mark the pushrod where it crosses the holes in the servo arm.

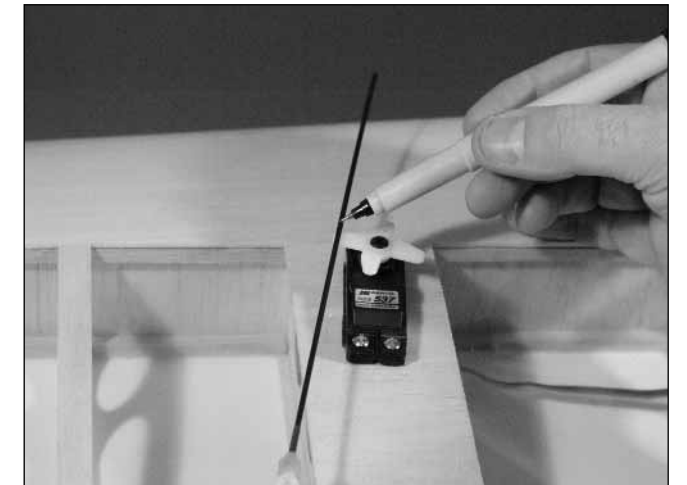

### □ □ Step 19

Bend the wire 90 degrees at the mark made in the previous step. Cut the wire 1/2" above the bend.

### □ □ Step 20

Slide the wire through the outer hole in the aileron servo arm. Secure the wire using a nylon wire keeper.

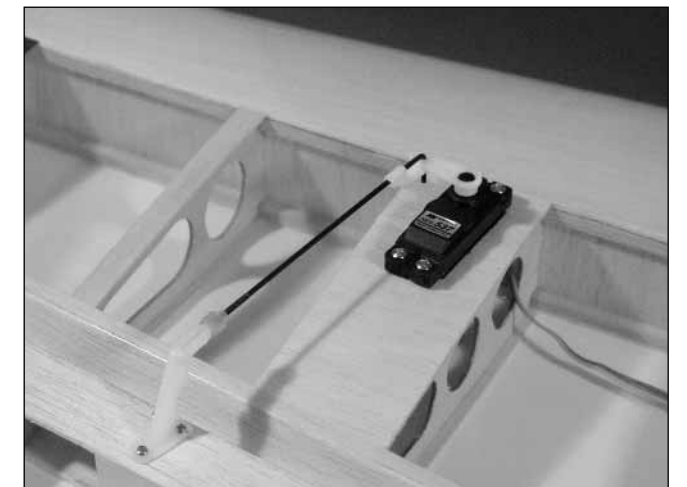

## Section 16: Linkage Installation

### Step 21

Repeat Steps 12 through 20 for the other aileron servo.

### Step 22

Slide a clevis retainer onto a nylon clevis. Thread a clevis onto an 18 <sup>3</sup>/<sub>4</sub>" pushrod wire a minimum of 10 turns onto the wire.

### Step 23

Center the throttle stick and trim with both the receiver and transmitter on. Install the throttle servo arm in the neutral position.

### Step 24

Install the throttle pushrod into the tube from the inside of the fuselage. Connect the clevis to the throttle servo arm.



### Step 25

Move the servo to the throttle closed position using the radio system. Manually move the throttle arm to the closed position. Mark the location where the pushrod crosses the servo arm using a felt-tipped pen.

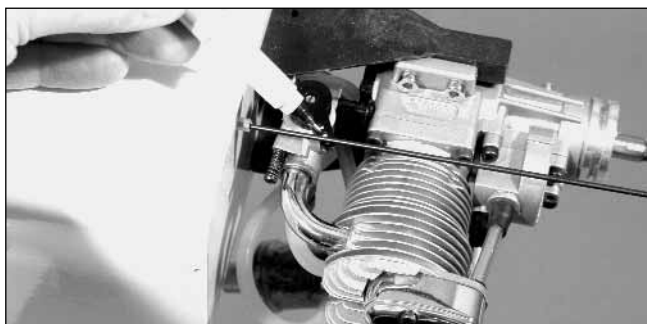

### Step 26

Make a Z-bend at the mark made in the last step. Remove the clevis and slide the pushrod into the pushrod tube from the firewall. Connect the pushrod to the throttle arm. You may need to remove the throttle arm to make the connection.

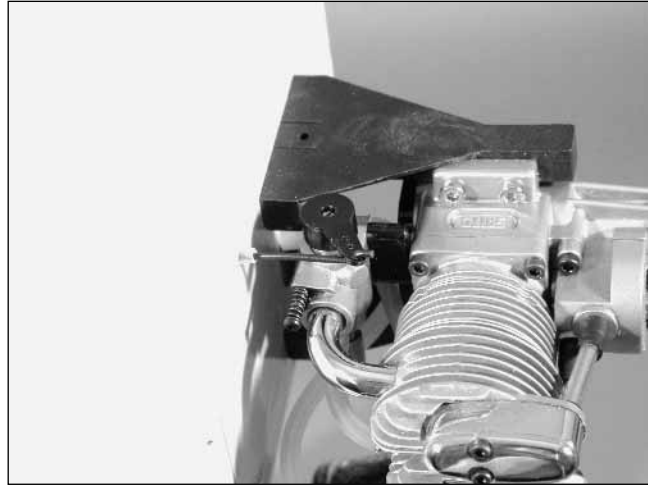

### Step 27

Reinstall the clevis and connect to the servo arm. Check the movement of the throttle to verify there is no binding at either low or high throttle. If there is, make the necessary adjustment to eliminate any binding. Install the throttle servo arm screw when complete.

### Step 28

Use scrap wood to make a brace for the throttle pushrod tube near the servo as shown.



## Section 17: Canopy and Decal Installation

### Required Parts

- Fuselage assembly
- Canopy

### Required Tools and Adhesives

- Canopy glue (RC-56)
- Sandpaper (medium grit)

Finally, the fun part of building your model. Adding details besides the ones provided can really dress up your plane and make it stand out at the field.

### Step 1

Install a pilot of your choosing. Use epoxy or Zap-A-Dap-A-Goo to secure the pilot.

### Step 2

Position the canopy onto the fuselage. Trace around the canopy and onto the hatch using a felt-tipped pen.



### Step 3

Lightly sand the inside edge of the canopy and slightly inside the line drawn on the hatch using medium sandpaper.

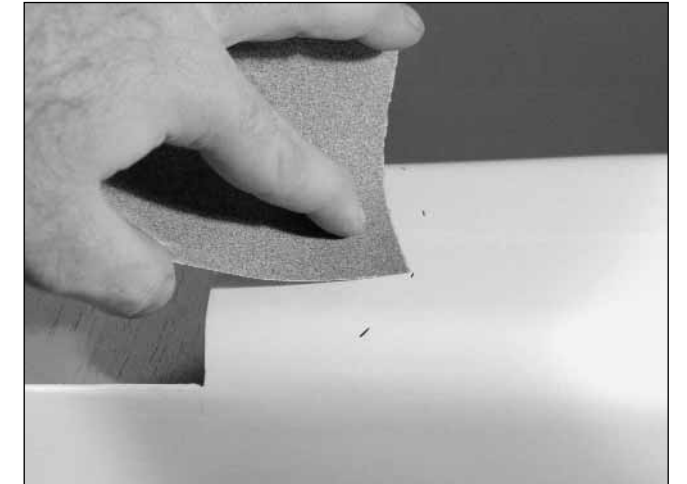

### Step 4

Apply a bead of RCZ56 Canopy Glue (ZINJ5007) around the inside edge of the canopy. Position the canopy onto the hatch. Use tape to hold the canopy secure until the glue fully cures.

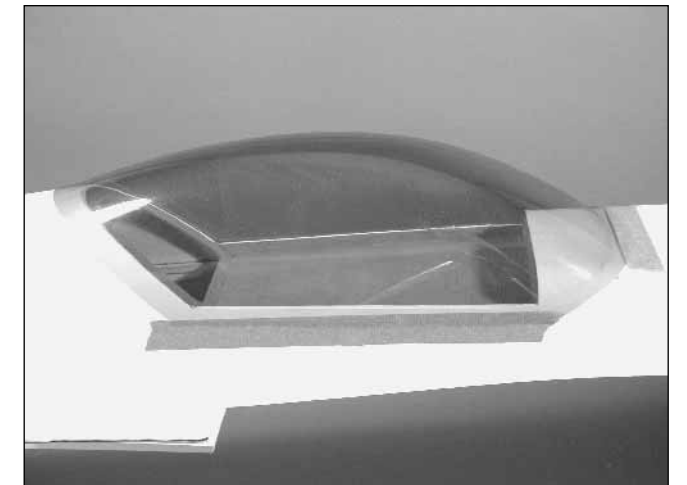

### Step 5

Apply the decals. Use the photos on the box to aid in their location.

# Control Throws and Center of Gravity

## Recommended CG Location

An important part of preparing the aircraft for flight is properly balancing the model. This is especially important when various engines are mounted.

### Caution: Do not inadvertently skip this step!

The recommended Center of Gravity (C.G.) range for the FuntanaS is 5 <sup>5</sup>/<sub>16</sub>" to 5 <sup>11</sup>/<sub>16</sub>" behind the leading edge of the wing measured at the fuselage sides. If necessary, move the battery pack or add weight to either the nose or the tail until the correct balance is achieved. Stick-on weights are available at your local hobby shop and work well for this purpose.

The following control throws offer a good place to start with your first flights. We recommend only one rate setting for the FuntanaS. As you become more familiar with the handling of your model, you may wish to add a second rate setting.

Once the control throws for the ailerons and flaps have been set, tighten the 4-40 nuts against the clevises to prevent them from loosening during flight. It is also highly suggested to use threadlocking compound.

### Recommended Control Throws

	<u>Low Rate</u>	<u>3D Rate</u>
Aileron	3/4" (9°) up 5/8" (6°) down	2 1/8" (27°) up 1 7/8" (23°) down
Elevator	7/8" (11°) up 7/8" (11°) down	2 5/8" (40°) up 2 5/8" (40°) down
Rudder	2" (25°) left 2" (25°) right	3 7/8" (45°) left 3 7/8" (45°) right

# Preflight at the Field

## Step 1

Before each flying session, range-check your radio. This is accomplished by turning on your transmitter with the antenna collapsed. Turn on the radio in your airplane. With your airplane on the ground, you should be able to walk 30 paces away from your airplane and still have complete control of all functions. If not, don't attempt to fly! Have your radio equipment checked out by the manufacturer.

## Step 2

Double-check that all controls (aileron, elevator, throttle, rudder) move in the correct direction.

## Step 3

Before you fly, be sure that your batteries are fully charged per the instructions included with your radio.

# Adjusting the Engine

## Step 1

Completely read the instructions included with your engine and follow the recommended break-in procedure.

## Step 2

At the field, adjust the engine to a slightly rich setting at full throttle and adjust the idle and low-speed needle so that a consistent idle is achieved.

## Step 3

Before you fly, be sure that your engine idles reliably, transitions and runs at all throttle settings. Only when this is achieved should any plane be considered ready for flight.

# 2003 Official AMA National Model Aircraft Safety Code

Effective January 1, 2003

Model Flying **MUST** be in accordance with this Code in order for AMA Liability Protection to apply.

## GENERAL

- 1) I will not fly my model aircraft in sanctioned events, air shows or model flying demonstrations until it has been proven to be airworthy by having been previously, successfully flight tested.
- 2) I will not fly my model higher than approximately 400 feet within 3 miles of an airport without notifying the airport operator. I will give right-of-way and avoid flying in the proximity of full-scale aircraft. Where necessary, an observer shall be utilized to supervise flying to avoid having models fly in the proximity of full-scale aircraft.
- 3) Where established, I will abide by the safety rules for the flying site I use, and I will not willfully and deliberately fly my models in a careless, reckless and/or dangerous manner.
- 4) The maximum takeoff weight of a model is 55 pounds, except models flown under Experimental Aircraft rules.
- 5) I will not fly my model unless it is identified with my name and address or AMA number, on or in the model. (This does not apply to models while being flown indoors.)
- 6) I will not operate models with metal-bladed propellers or with gaseous boosts, in which gases other than air enter their internal combustion engine(s); nor will I operate models with extremely hazardous fuels such as those containing tetranitromethane or hydrazine.

- 7) I will not operate models with pyrotechnics (any device that explodes, burns, or propels a projectile of any kind) including, but not limited to, rockets, explosive bombs dropped from models, smoke bombs, all explosive gases (such as hydrogen filled balloons), ground mounted devices launching a projectile. The only exceptions permitted are rockets flown in accordance with the National Model Rocketry Safety Code or those permanently attached (as per JATO use); also those items authorized for Air Show Team use as defined by AST Advisory Committee (document available from AMA HQ). In any case, models using rocket motors as a primary means of propulsion are limited to a maximum weight of 3.3 pounds and a G series motor. (A model aircraft is defined as an aircraft with or without engine, not able to carry a human being.)
- 8) I will not consume alcoholic beverages prior to, nor during, participation in any model operations.
- 9) Children under 6 years old are only allowed on the flight line as a pilot or while under flight instruction.

## RADIO CONTROL

- 1) I will have completed a successful radio equipment ground range check before the first flight of a new or repaired model.
- 2) I will not fly my model aircraft in the presence of spectators until I become a qualified flier, unless assisted by an experienced helper.
- 3) At all flying sites a straight or curved line(s) must be established in front of which all flying takes place with the other side for spectators. Only personnel involved with flying the aircraft are allowed at or in the front of the flight line. Intentional flying behind the flight line is prohibited.

# 2003 Official AMA National Model Aircraft Safety Code

Continued

4) I will operate my model using only radio control frequencies currently allowed by the Federal Communications Commission. (Only properly licensed Amateurs are authorized to operate equipment on Amateur Band frequencies.)

5) Flying sites separated by three miles or more are considered safe from site-to site interference, even when both sites use the same frequencies. Any circumstances under three miles separation require a frequency management arrangement which may be either an allocation of specific frequencies for each site or testing to determine that freedom from interference exists. Allocation plans or interference test reports shall be signed by the parties involved and provided to AMA Headquarters. Documents of agreement and reports may exist between (1) two or more AMA Chartered Clubs, (2) AMA clubs and individual AMA members not associated with AMA Clubs, or (3) two or more individual AMA members.

6) For Combat, distance between combat engagement line and spectator line will be 500 feet per cubic inch of engine displacement. (Example: .40 engine = 200 feet.); electric motors will be based on equivalent combustion engine size. Additional safety requirements will be per the RC Combat section of the current Competition Regulations.

7) At air shows or model flying demonstrations a single straight line must be established, one side of which is for flying, with the other side for spectators.

8) With the exception of events flown under AMA Competition rules, after launch, except for pilots or helpers being used, no powered model may be flown closer than 25 feet to any person.

9) Under no circumstances may a pilot or other person touch a powered model in flight.

## Organized RC Racing Event

10) An RC racing event, whether or not an AMA Rule Book event, is one in which model aircraft compete in flight over a prescribed course with the objective of finishing the course faster to determine the winner.

A. In every organized racing event in which contestants, callers and officials are on the course:

1. All officials, callers and contestants must properly wear helmets, which are OSHA, DOT, ANSI, SNELL or NOCSAE approved or comparable standard while on the racecourse.

2. All officials will be off the course except for the starter and their assistant.

3."On the course" is defined to mean any area beyond the pilot/staging area where actual flying takes place.

B. I will not fly my model aircraft in any organized racing event which does not comply with paragraph A above or which allows models over 20 pounds unless that competition event is AMA sanctioned.

C. Distance from the pylon to the nearest spectator (line) will be in accordance with the current Competition Regulations under the RC Pylon Racing section for the specific event pending two or three pylon course layout.

11) RC Night flying is limited to low performance models (less than 100 mph). The models must be equipped with a lighting system that clearly defines the aircraft's attitude at all times.

If you're looking for a 4-stroke to power your airplane, you'll want to check out Saito's latest release, Saito's new .72 4-stroke. It's the lightest weight engine in this 4-cycle displacement category.

The .72 features an all-new crankcase with the same mounting dimensions as the Saito .56. This is achieved by narrowing the case just below the mounting flanges.

On the bench we compared the new .72 to the Saito .65 and to its nearest competitor using several different props. The new .72 consistently turned 400-600 rpm more than its .65 sibling and 200-300 rpm more than its nearest competitor on the same fuel. Also, the .72 weighs 3 ounces less than both, giving a much greater power-to-weight ratio than other brands.

Saito's .72 is available in a standard version or a Golden Knight version featuring a gloss black powder-coated finish with gold rocker covers. For overpowering performance at a fraction of the weight, check out Saito's new .72.



Ounce for ounce, Evolution's .46 NT is the best value in its class. It easily outperforms many of its more expensive competitors, provides silky smooth transition, and gives you the unparalleled tuning ease of SetRight needle valves. No other .46 offers as much bang for the buck.

