

GOBLIN

HELICOPTER

MANUAL

GOBLIN 380 BUDDY



SAB HELI DIVISION

Goblin 380 BUDDY Manual

Release 1.1 - November 2019

WORLD DISTRIBUTION

www.goblin-helicopter.com

For sales inquiries, please email: sales@goblin-helicopter.com

For information, please email: support@goblin-helicopter.com

Attention: If you are a consumer and have questions or need of assistance,
please contact the retailer where you made the purchased first.

EUROPEAN DISTRIBUTION

www.sabitaly.it

For sales inquiries, please email: sales@sabitaly.it

For information, please email: info@sabitaly.it

Attention: If you are a consumer and have questions or need of assistance,
please contact the retailer where you made the purchased first.

VERY IMPORTANT

On the main plate you can see your serial number . Please take a moment to register your kit online via our web site at:



<http://www.goblin-helicopter.com>

It is extremely important that you take a moment to register your helicopter with us. This is the only way to ensure that you are properly informed about changes to your kit, such as upgrades, retrofits and other important developments. SAB Heli Division cannot be held responsible for issues arising with your model and will not provide support unless you register your serial number.

Thank you for your purchase, we hope you enjoy your new Goblin helicopter!

SAB Heli Division

INDEX

- | | | |
|--|---|---|
| 1 – Specifications | 7 – Assembling The Modules | 13 – Tail Assembly |
| 2 – Important Notes  | 8 – Installation of Swashplate Servos | 14 – Installation of the Boom, Canopy |
| 3 – Components and Box | 9 – Tail Servo Assembly | 15 – Battery |
| 4 – Carbon frame Assembly | 10 – Installation of The Motor | 16 – In flight  |
| 5 – Transmission Assembly | 11 – Installation of The ESC | 17 – Maintenance |
| 6 – Main Rotor Assembly | 12 – Installation of Flybarless Unit and RX | 18 – Exploded Views |
| | | 19 – Spare Parts |

SPECIFICATIONS

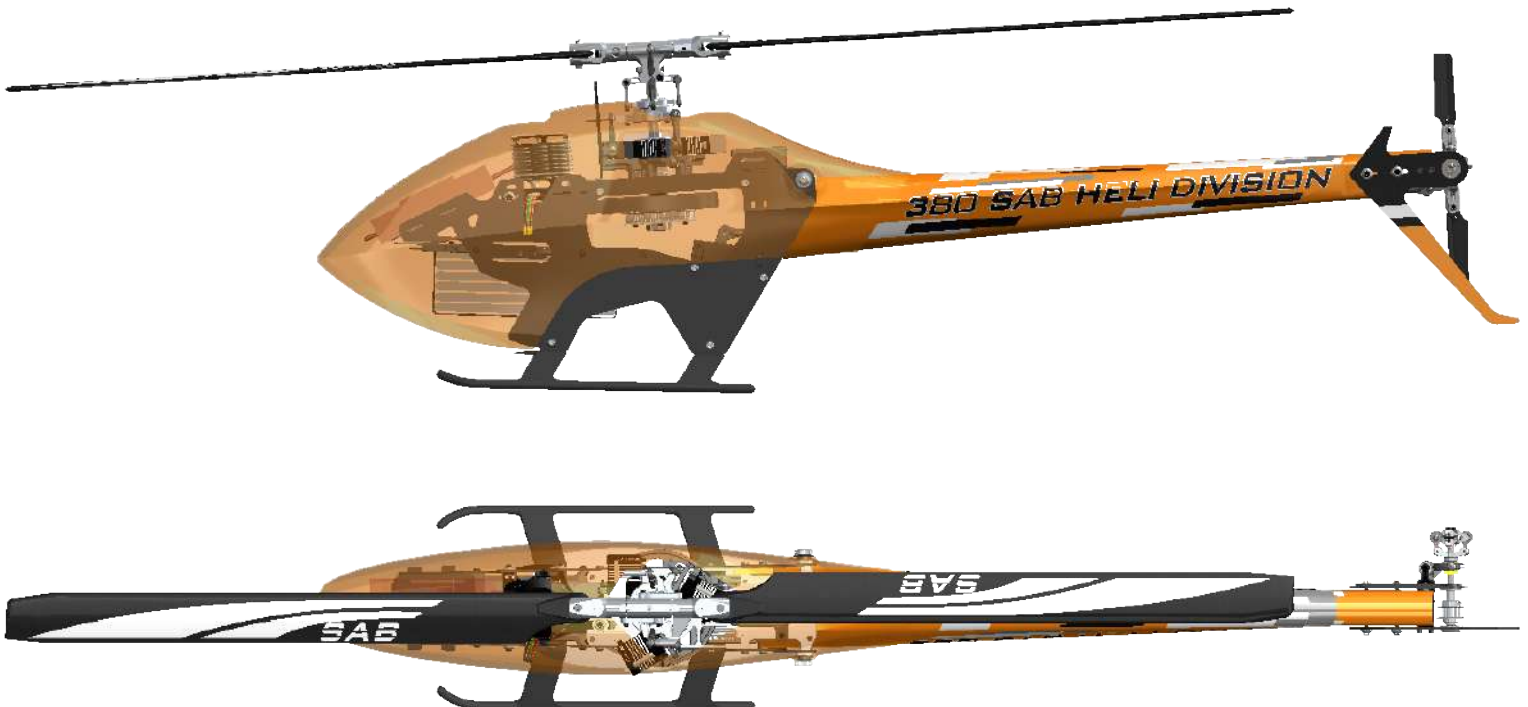

- Main rotor diameter : 856mm.
- Main blade length : 380mm.
- Tail rotor diameter : 192mm.
- Tail blade length : 70mm.
- Main shaft diameter : 8mm.
- Tail shaft diameter : 5mm.
- Spindle diameter : 5mm.

Motor size: Maximum 41mm diameter, maximum height 41mm.
 Battery compartment: 44x44x130mm.



IMPORTANT NOTES

- *This radio controlled helicopter is not a toy.
- *This radio controlled helicopter can be very dangerous.
- *This radio controlled helicopter is a technically complex device which has to be built and handled very carefully.
- *This radio controlled helicopter must be built following these instructions. This manual provides the necessary information to correctly assemble the model. It is necessary to carefully follow all the instructions.
- *Inexperienced pilots must be monitored by expert pilots.
- *All operators must wear safety glasses and take appropriate safety precautions.
- *A radio controlled helicopter must only be used in open spaces without obstacles, and far enough from people to minimize the possibility of accidents or of injury to property or persons.
- *A radio controlled helicopter can behave in an unexpected manner, causing loss of control of the model, making it very dangerous.
- *Lack of care with assembly or maintenance can result in an unreliable and dangerous model.

***Neither SAB Heli Division nor its agents have any control over the assembly, maintenance and use of this product. Therefore, no responsibility can be traced back to the manufacturer. You hereby agree to release SAB Heli Division from any responsibility or liability arising from the use of this product.**

SAFETY GUIDELINES

- *Fly only in areas dedicated to the use of model helicopters.
- *Follow all control procedures for the radio frequency system.
- *It is necessary that you know your radio system well. Check all functions of the transmitter before every flight.
- *The blades of the model rotate at a very high speed; be aware of the danger they pose and the damage they may cause.
- *Never fly in the vicinity of other people.

DAMAGE LIMITS

SAB HELI DIVISION SHALL NOT BE LIABLE FOR SPECIAL, INDIRECT OR CONSEQUENTIAL DAMAGES, LOSS OF PROFITS OR PRODUCTION OR COMMERCIAL LOSS IN ANY WAY CONNECTED WITH THE PRODUCT, WHETHER SUCH CLAIM IS BASED IN CONTRACT, WARRANTY, NEGLIGENCE, OR STRICT LIABILITY. Further, in no event shall the liability of SAB Heli Division exceed the individual price of the Product on which liability is asserted. As SAB Heli Division has no control over use, setup, final assembly, modification or misuse, no liability shall be assumed nor accepted for any resulting damage or injury. By the act of use, setup or assembly the user accepts all resulting liability. If you as the Purchaser or user are not prepared to accept the liability associated with the use of this Product, you are advised to return this Product immediately in new and unused condition to the place of purchase.

LIMITED WARRANTY

SAB Heli Division reserves the right to change or modify this warranty without notice and disclaims all other warranties, express or implied.

- (a)** This warranty is limited to the original Purchaser (“Purchaser”) and is not transferable. REPLACEMENT AS PROVIDED UNDER THIS WARRANTY IS THE EXCLUSIVE REMEDY OF THE PURCHASER This warranty covers only those Products purchased from an authorized SAB Heli Division dealer. Third party transactions are not covered by this warranty. Proof of purchase is required for warranty claims.
- (b)** Limitations- SAB HELI DIVISION MAKES NO WARRANTY OR REPRESENTATION, EXPRESS OR IMPLIED, ABOUT NONINFRINGEMENT, MERCHANTABILITY OR FITNESS FOR A PARTICULAR PURPOSE OF THE PRODUCT. THE PURCHASER ACKNOWLEDGES THAT THEY ALONE HAVE DETERMINED THAT THE PRODUCT WILL SUITABLY MEET THE REQUIREMENTS OF THE PURCHASER’S INTENDED USE.
- (c)** Purchaser Remedy- SAB Heli Division’s sole obligation hereunder shall be that SAB Heli Division will, at its option, replace any Product determined by SAB Heli Division to be defective In the event of a defect, this is the Purchaser’s exclusive remedy. Replacement decisions are at the sole discretion of SAB Heli Division. This warranty does not cover cosmetic damage or damage due to acts of God, accident, misuse, abuse, negligence, commercial use, or modification of or to any part of the Product. This warranty does not cover damage due to improper installation, operation, maintenance or attempted repair by anyone.



Important



Use retaining compound (eg Loctite 648)



Use retaining compound (eg Loctite 243)



Use CA Glue



Use Proper Lubricant

⇒ Bag xx Indicates that for this assembly phase you need materials that are in Bag xx.

ADDITIONAL COMPONENTS REQUIRED

- *Electric Motor: 850 - 1000Kv:
Maximum diameter 41mm.
Maximum height 41mm.
Pinion shaft diameter 5 mm.
- *Speed controller: minimum 60A , extreme 3D Flight 70-90A.
- *Batteries: 6S-1800 mAh (1500 - 2600 mAh) .
- *1 flybarless 3 axis control unit.
- *Radio power system, if not integrated with the ESC.
- *3 micro cyclic servos.
- *1 mini (midi) tail rotor servo.
- *6 channel radio control system on 2.4 GHz.

(See configuration examples on page 14).

TOOLS, LUBRICANTS, ADHESIVES

- *Generic pliers.
- *Hexagonal driver, size 1.5,2,2.5mm.
- *5.5mm Socket wrench (for M3 nuts).
- *7mm Hex fork wrench (for M4 nuts).
- *Medium threadlocker (eg. Loctite 243).
- *Strong retaining compound (eg. Loctite 648).
- *Spray lubricant (eg. Try-Flow Oil).
- *Grease (eg. Microlube GL261).
- *Cyanoacrylate adhesive.
- *Pitch Gauge (for set-up).
- *Soldering equipment (for motor and ESC wiring).

Inside the main box there are:

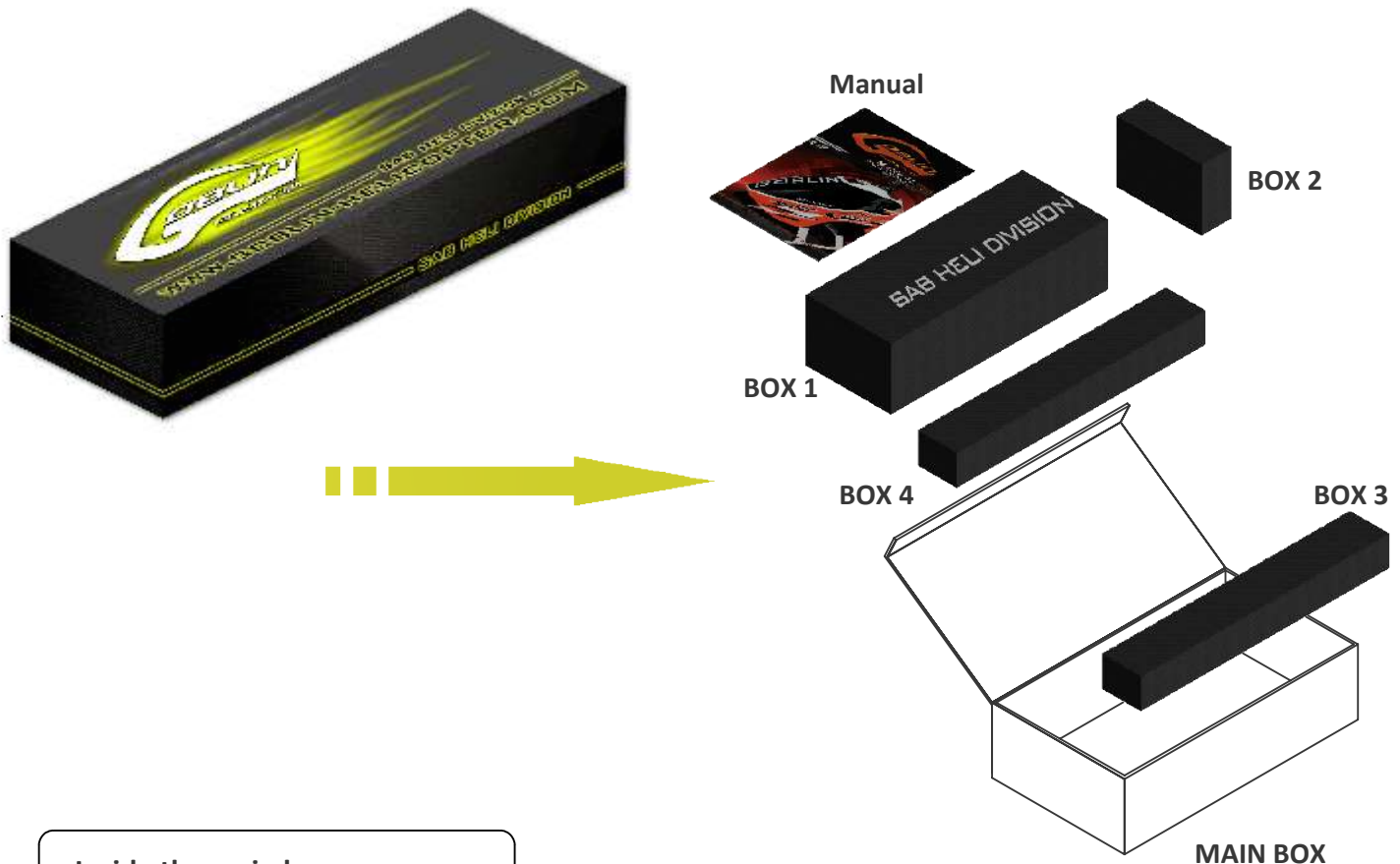

Inside the main box:

- Box 1: Canopy.
Frames.
Blade Holder.
Landing Gear.
Battery Support.
Tail Fin Assembly.
- Box 2: Combo Components (Optional).
- Box 3: Boom.
Carbon Rod.
Blades + Tail Blades.
- Box 4: Mechanical parts, Bags.

The assembly process is described in the following chapters. Each chapter provides you with the box and bag you will need for that chapter. The information is printed at the top of every page.

4-Carbon Frame

 The manufacturing process of the carbon parts often leaves micro-burrs and sharp edges. We recommend de-burring the edges to minimize the risks of electrical wire cuts, etc. This is particularly important in the areas shown in red.

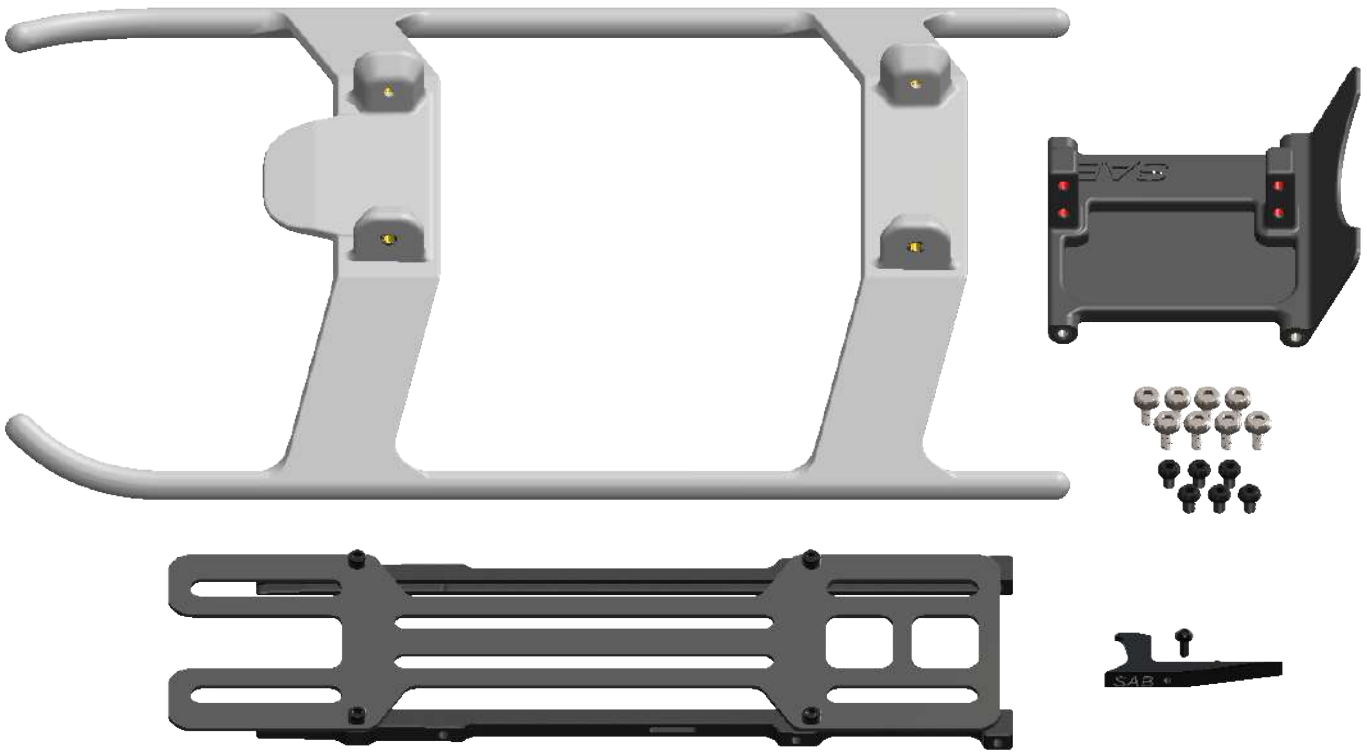

Battery Guide Assembly

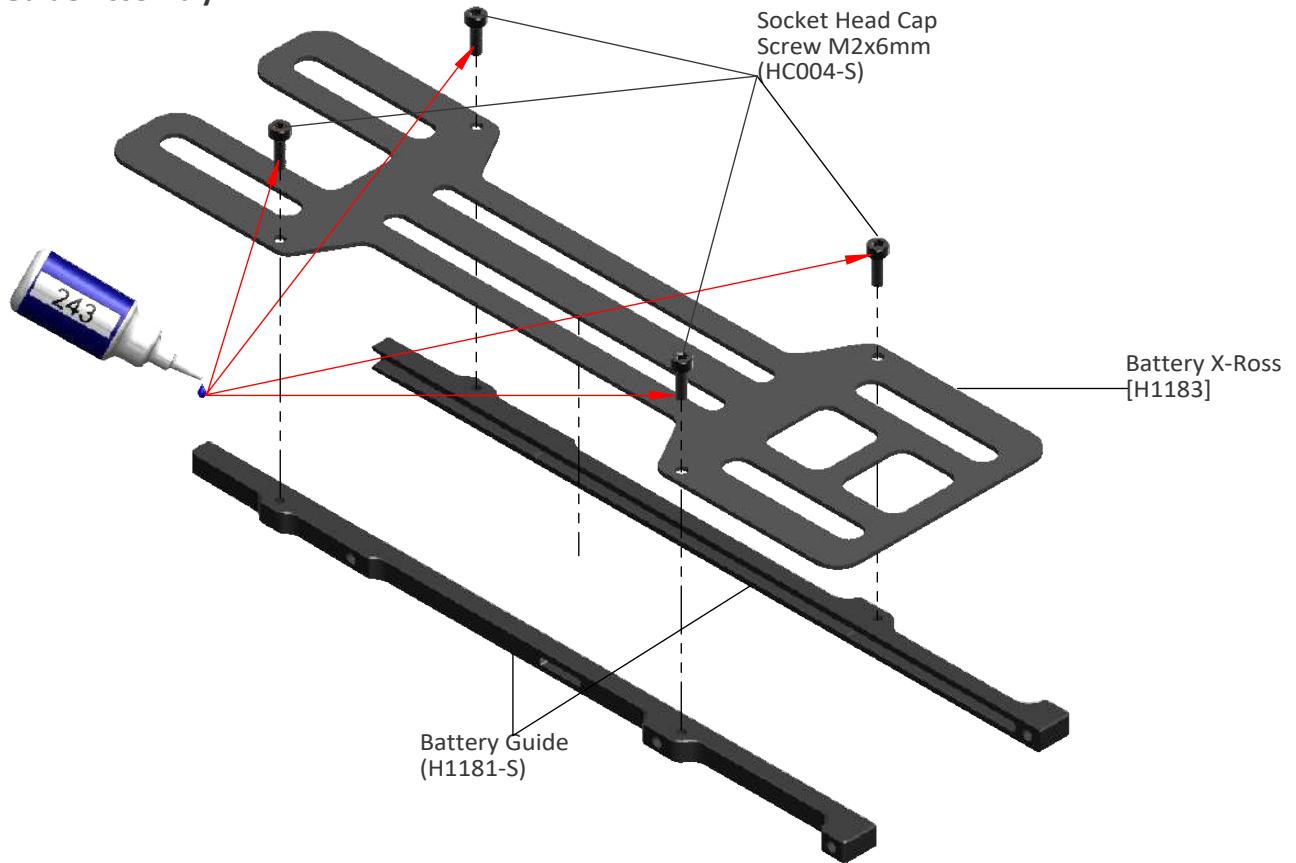

Right Main Frame Assembly

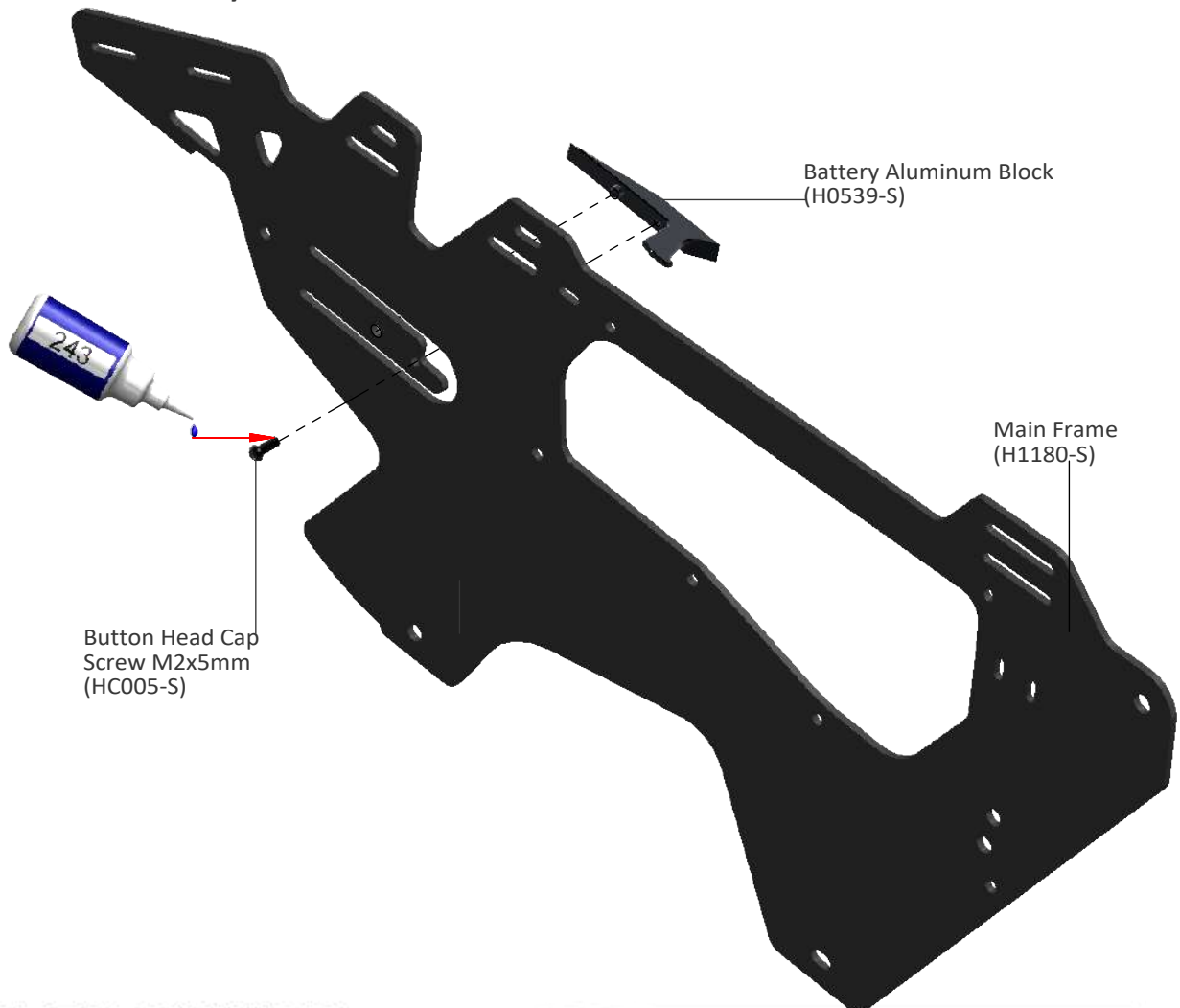

Left Main Frame Assembly

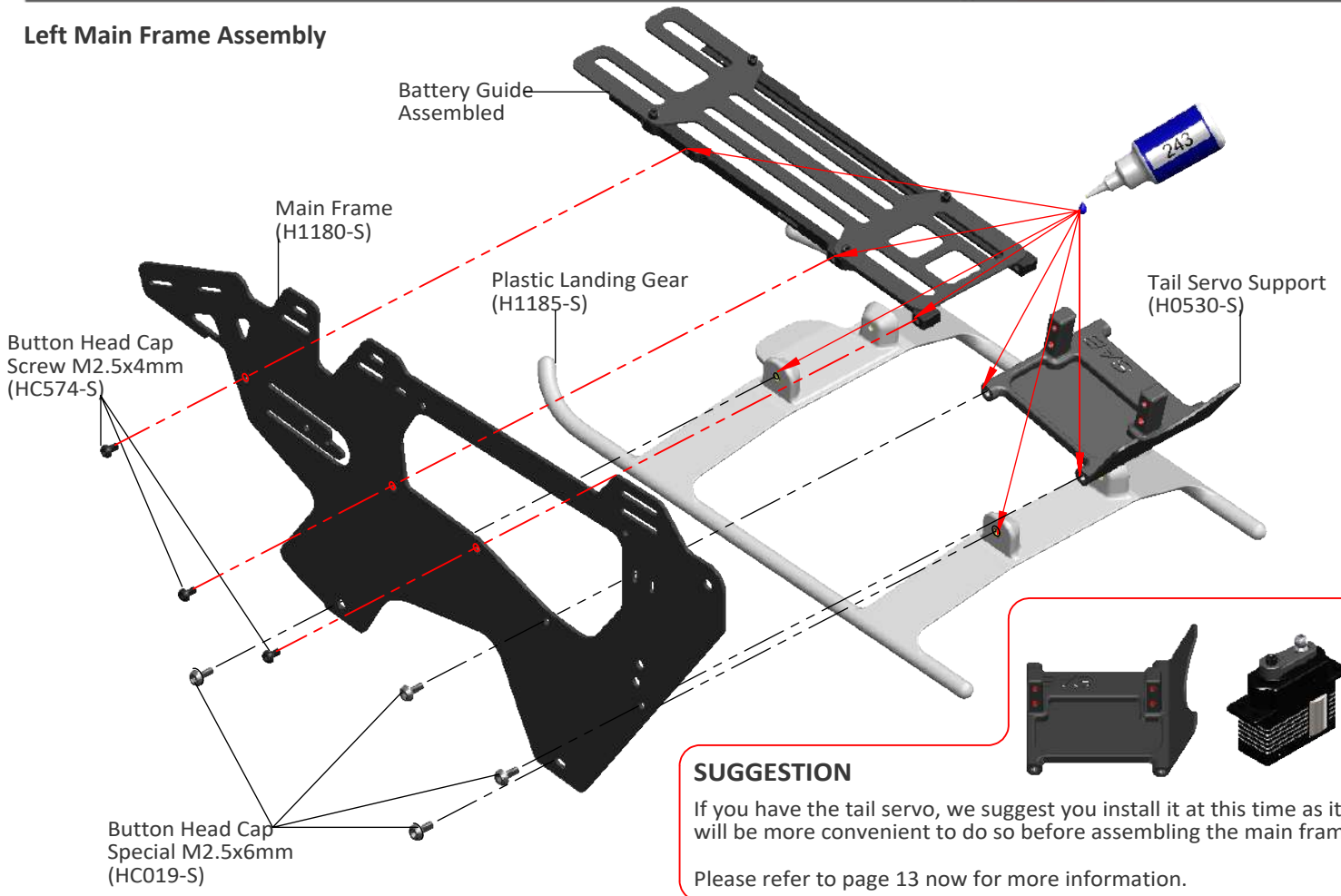

Main Frame Assembly

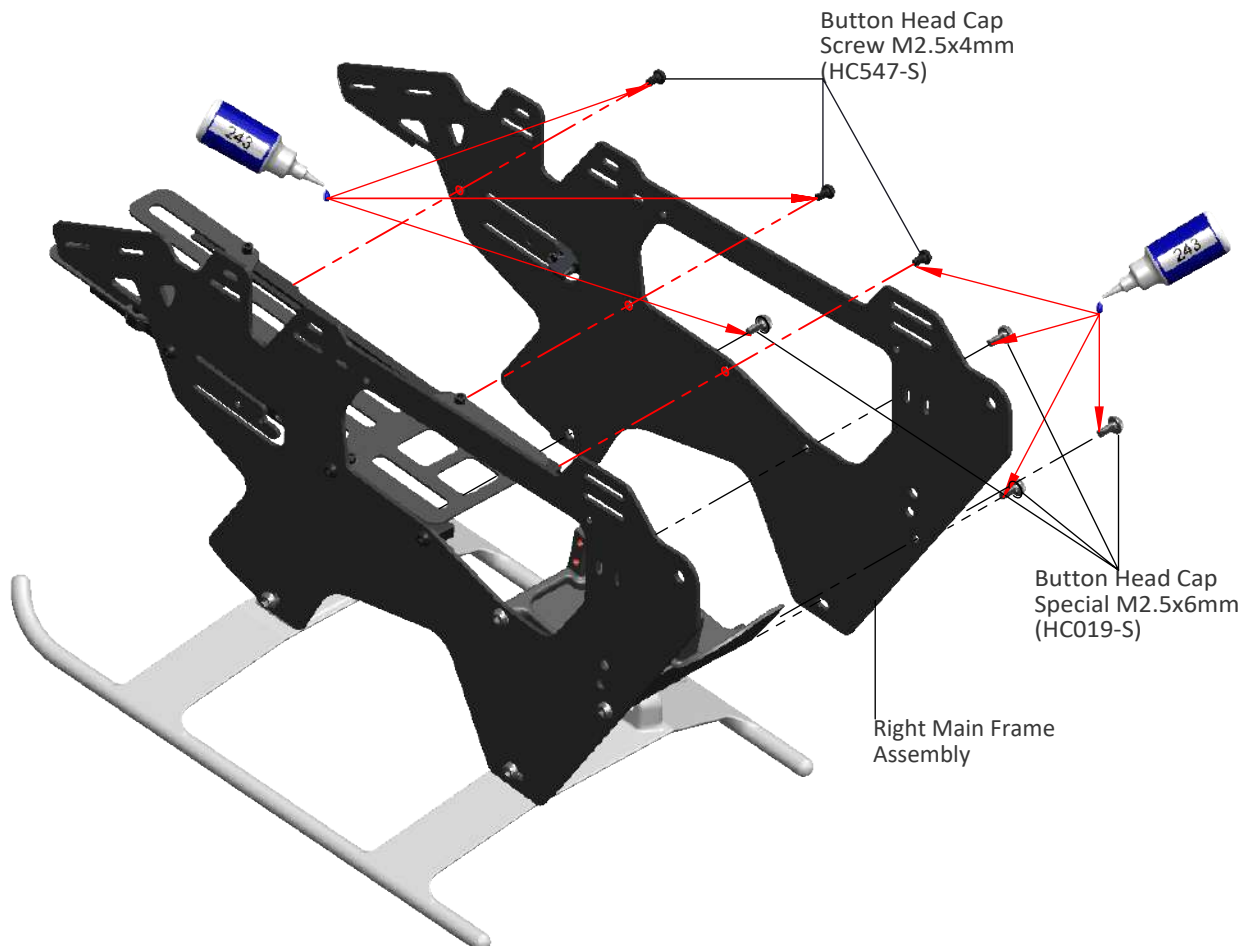

Main Shaft Support Assembly

Main Shaft Support (H0522-S)

Bearing $\varnothing 8 \times \varnothing 16 \times 5 \text{mm}$ (HC419-S)

Already Assembled

Main Shaft Assembly

Main Shaft Support Assembly

Main Shaft (H0507-S)

Socket Head Cap Screw M2.5x8mm (HC020-S)

Main Shaft Assembly

Socket Head Cap Screw M2.5x8mm (HC020-S)

Socket Head Cap Screw M2.5x8mm (HC020-S)

Shims $\varnothing 8 \times \varnothing 12 \times 0,1 \text{mm}$ (HC462-S)

Tighten the three screw M2.5. After tightening, check the axial play of the main shaft. It is possible to reduce any axial play by adding shims.

IMPORTANT: Very carefully check to make sure you can turn the main shaft freely. If you feel too much friction, you have used too many shims, you can remove a shim until the shaft turns freely.

Bearing $\varnothing 8 \times \varnothing 16 \times 5 \text{mm}$ (HC419-S)

Already Assembled

Main Plate (H0519-S)

Serial number

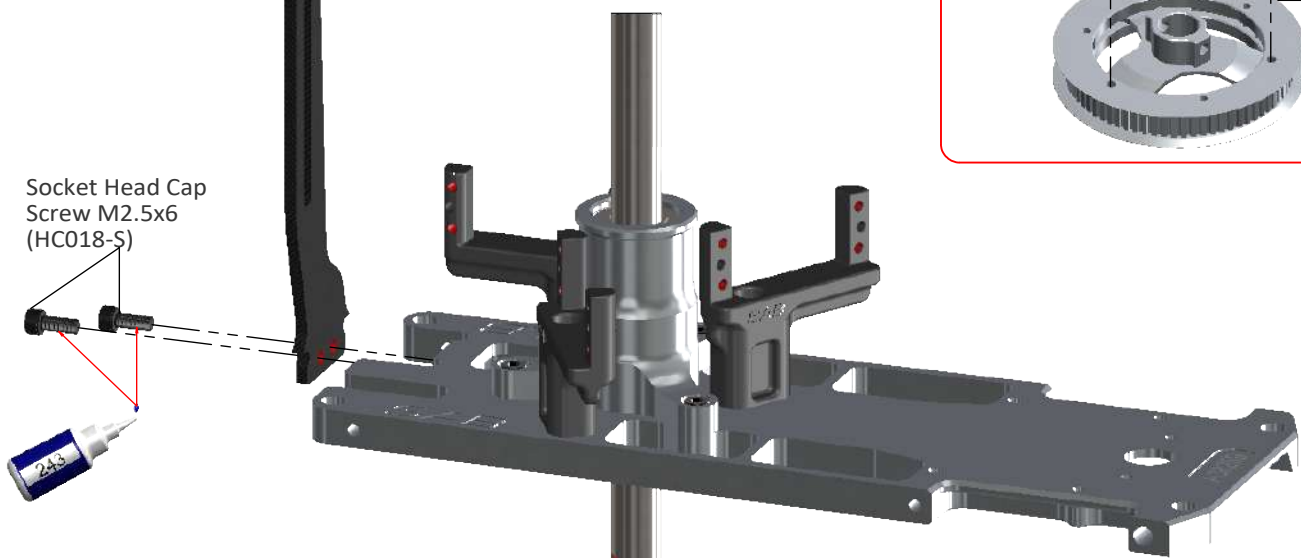
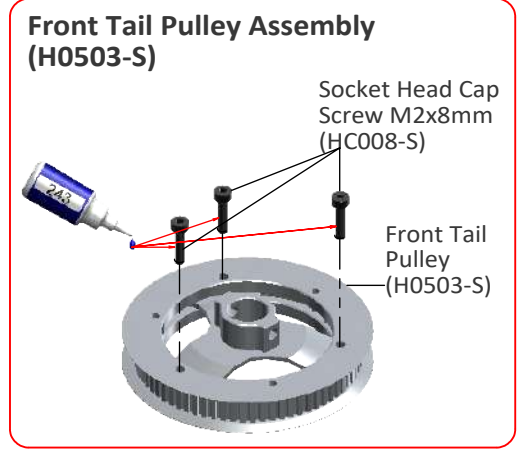
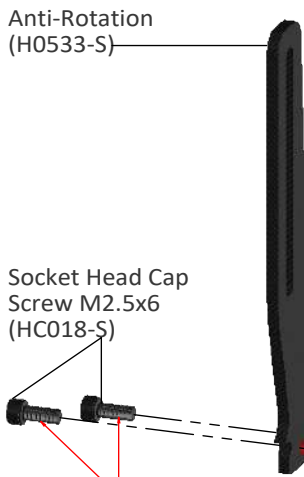
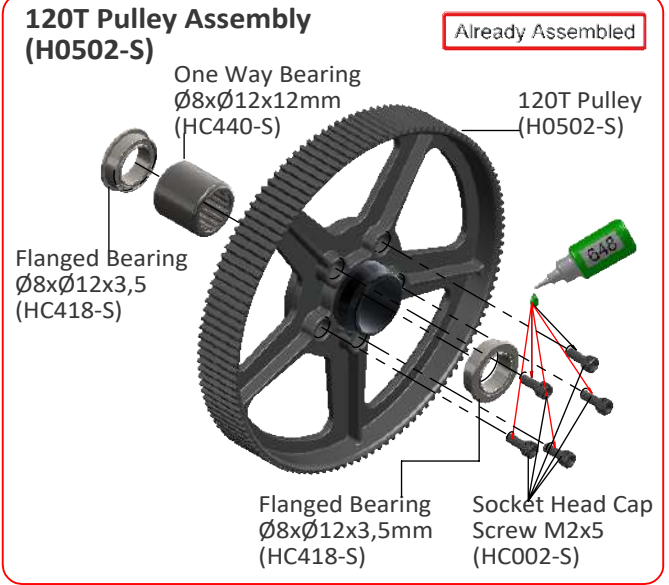
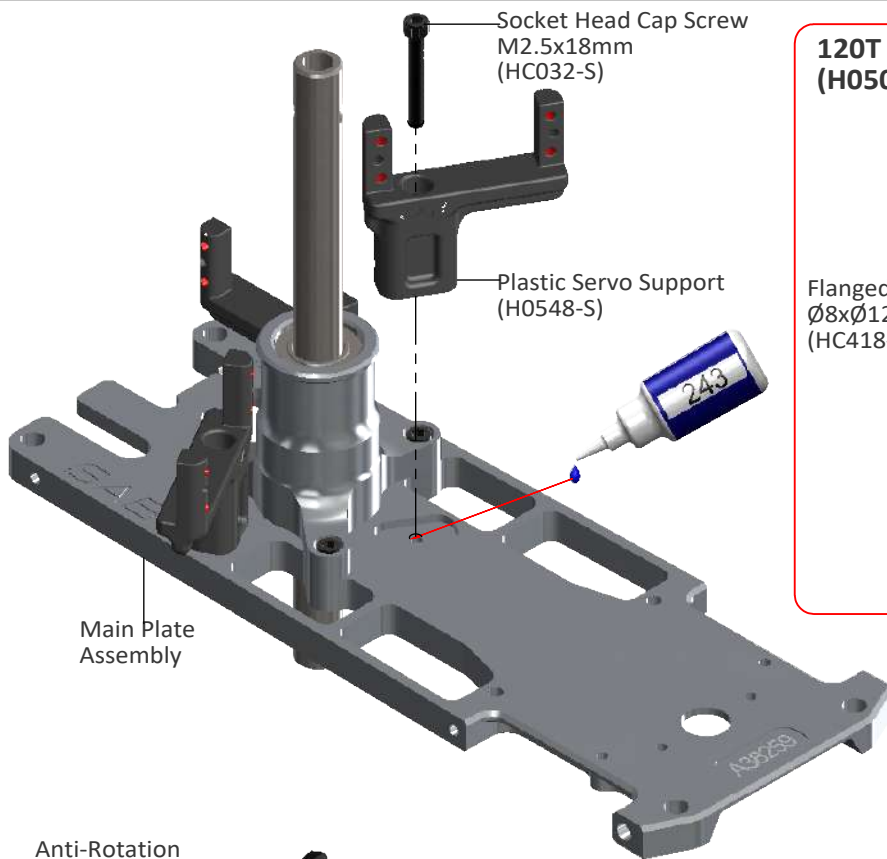

Note:
Add or remove shims to get approximately 0.2-0.4mm play.

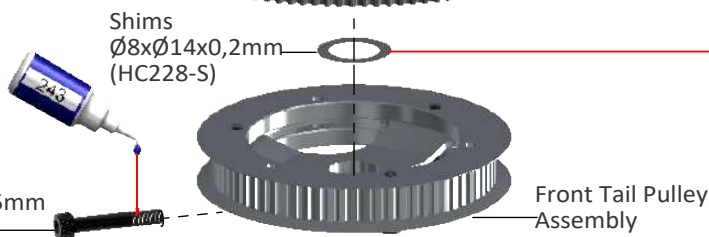

Radius Arm Assembly ... x 2

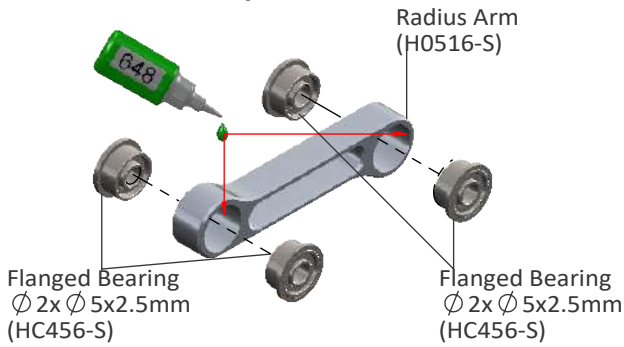

Radius Plastic Arm Assembly ... x 2

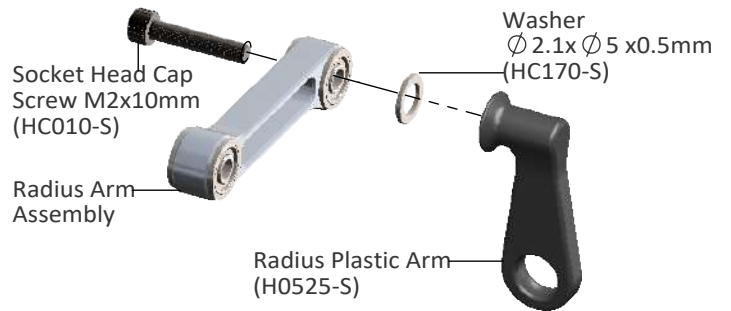

NOTE: Tighten with care, the arm must move freely.

Center Hub Assembly

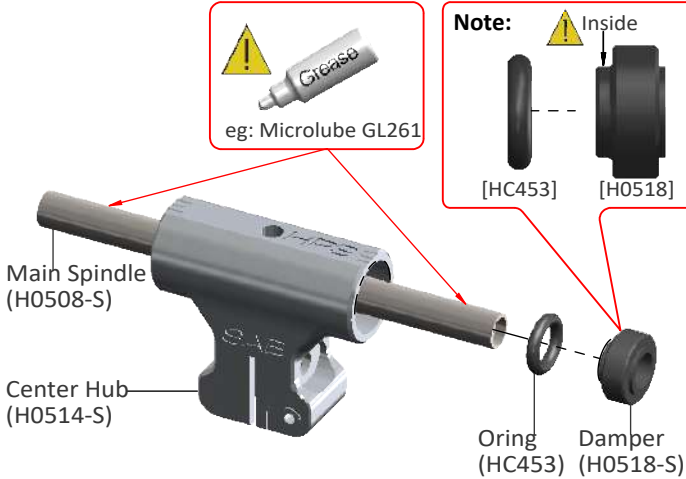

Main Blade Grip Assemblyx2

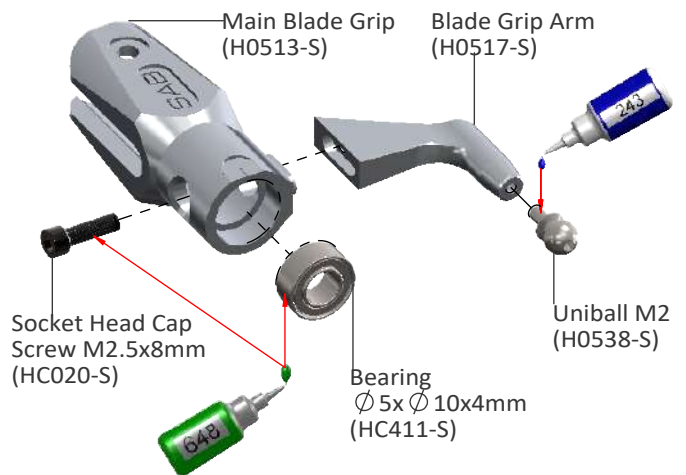

Head HPS Assembly

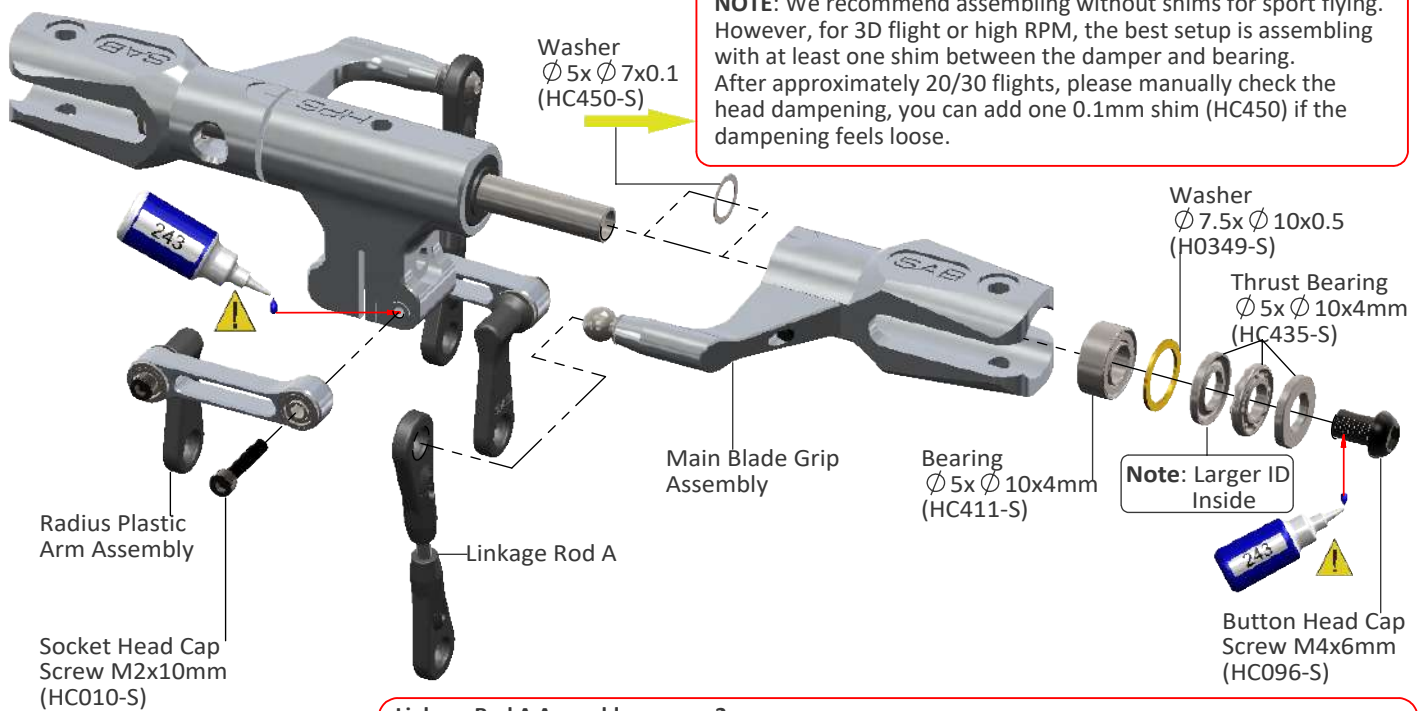

NOTE: We recommend assembling without shims for sport flying. However, for 3D flight or high RPM, the best setup is assembling with at least one shim between the damper and bearing. After approximately 20/30 flights, please manually check the head dampening, you can add one 0.1mm shim (HC450) if the dampening feels loose.

Linkage Rod A Assemblyx2

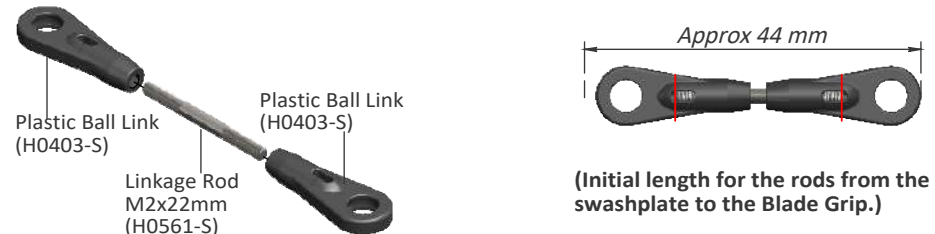

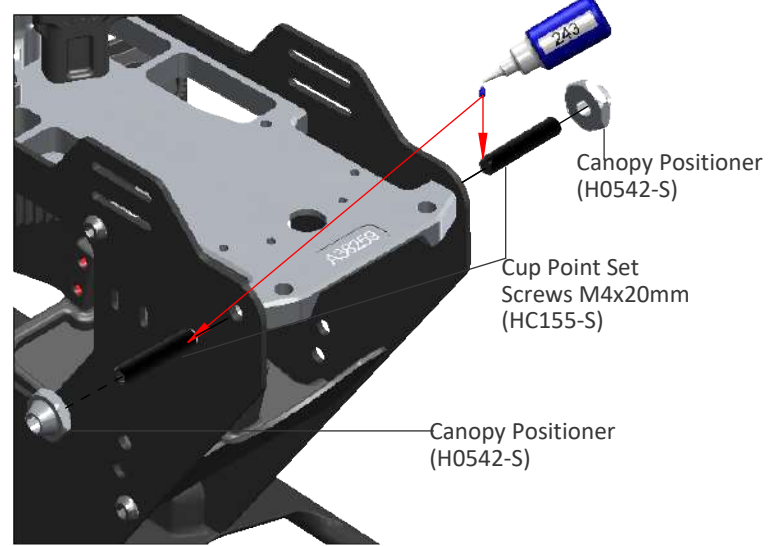
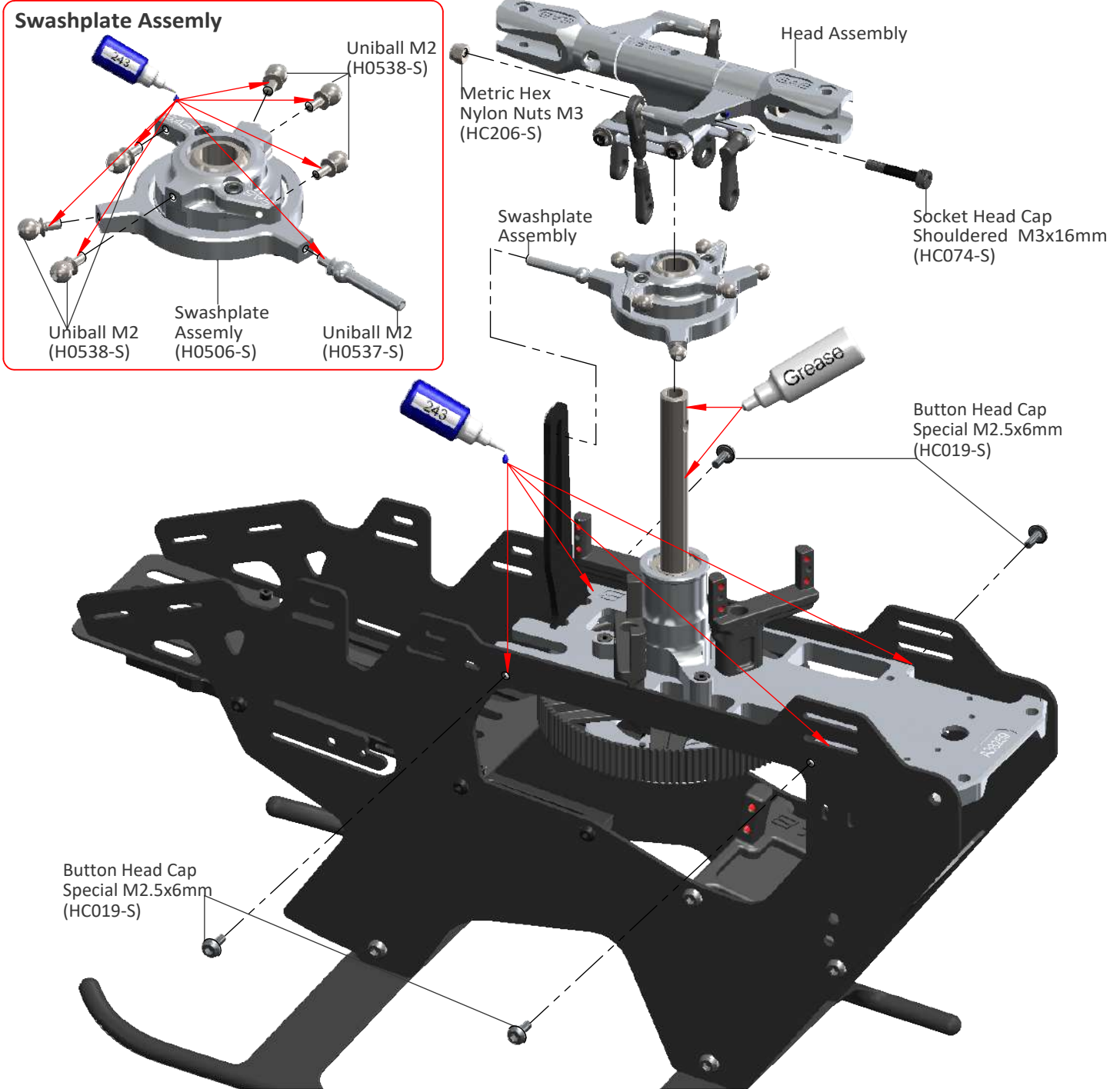

NOTE:
Keep the distance between the end of the canopy retainer H0542 and the frame at approximately 12mm.

12 mm

INSTALLATION OF SWASHPLATE SERVOS

The linkage ball must be positioned approximately **13-15 mm** out on the servo arm (**Figure 1**), it is recommended to use the SAB servo arm p/n [HA052]. Because of the 120° placement of the servos in the Goblin, the arms are difficult to access. For this reason it is advisable to ensure alignment of the servo arms before installation of the servos in the model. Proceed with installation following the instructions below. **Figure 2** shows a completed installation.

Fig. 1

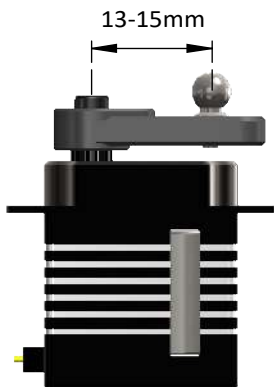
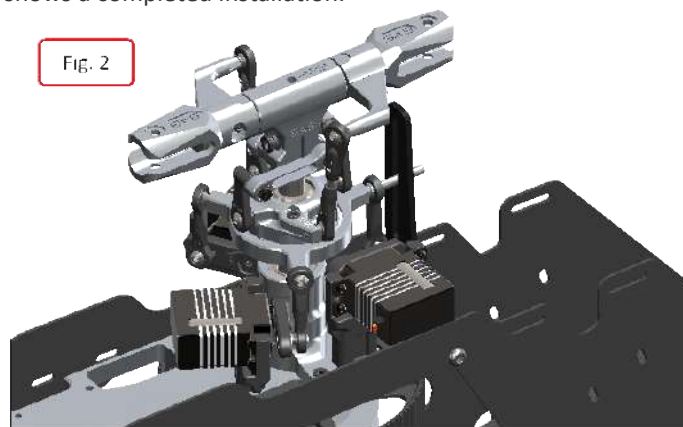
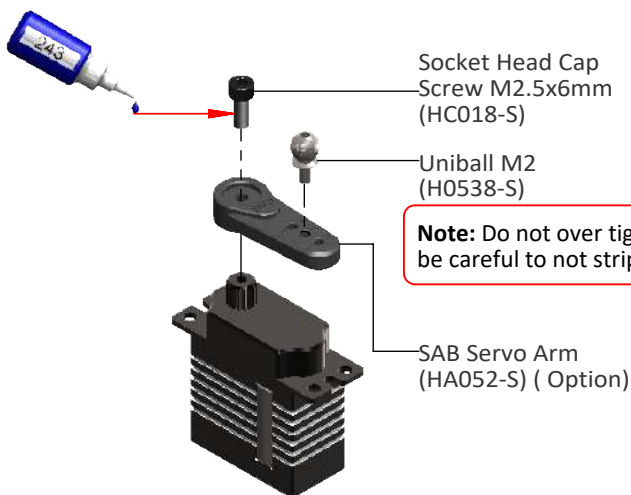

Fig. 2



The rods going from the servos to the swash plate must be as vertical as possible. (Red line in Figure 4)
 Not all servos are equal, so for proper alignment you can choose to use the supplied spacer H0566 under the uniball H0538.

Fig. 4



Note: Do not over tighten, be careful to not strip plastic.

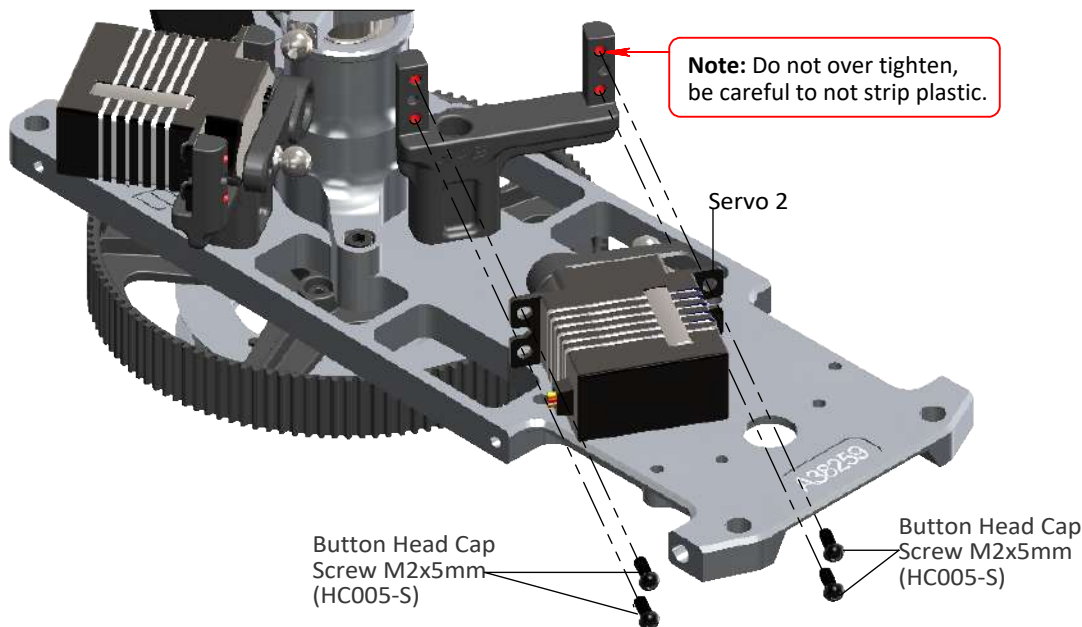
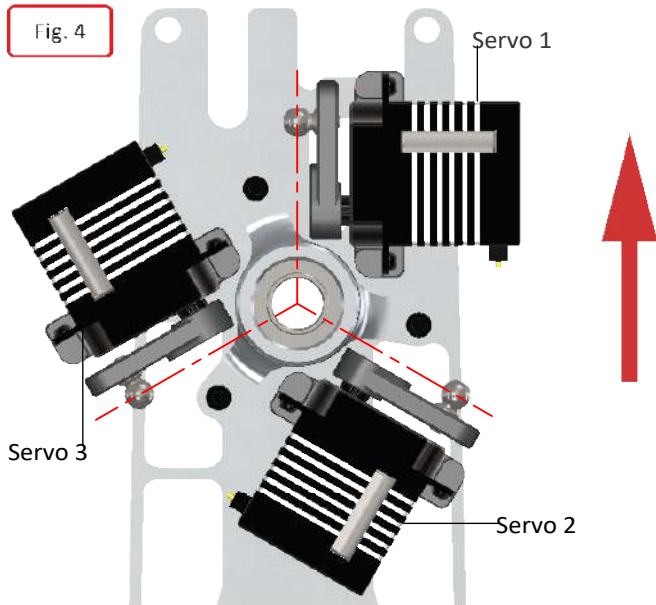

Note: Do not over tighten, be careful to not strip plastic.



Tip on cable routing

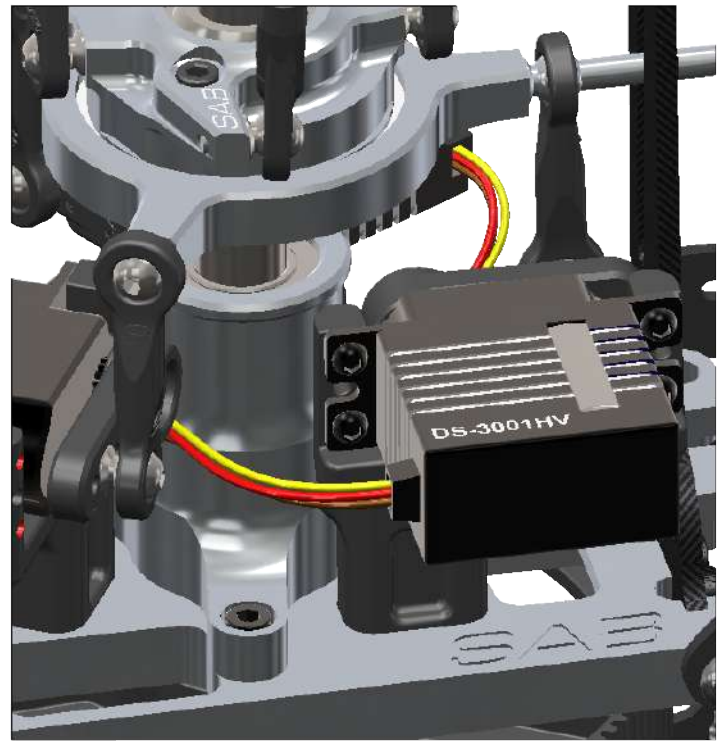
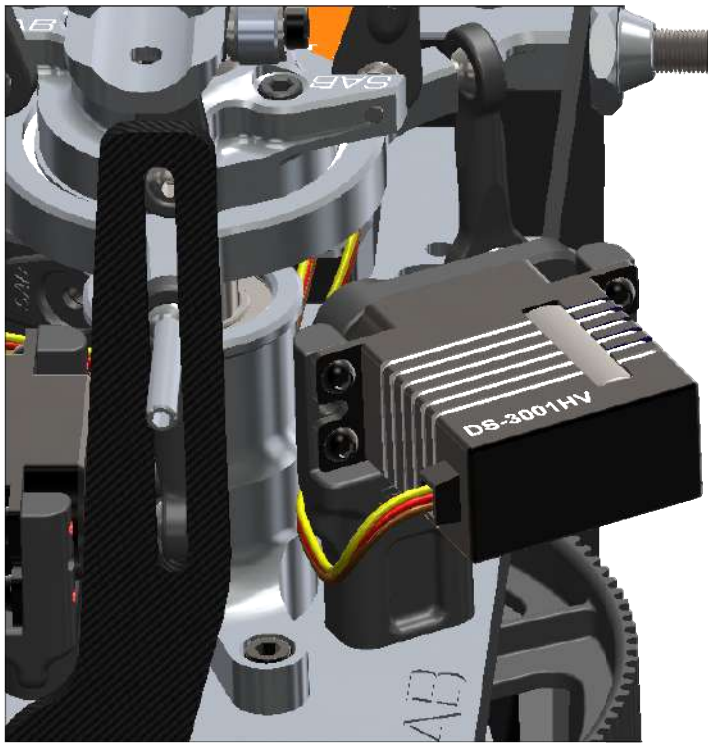
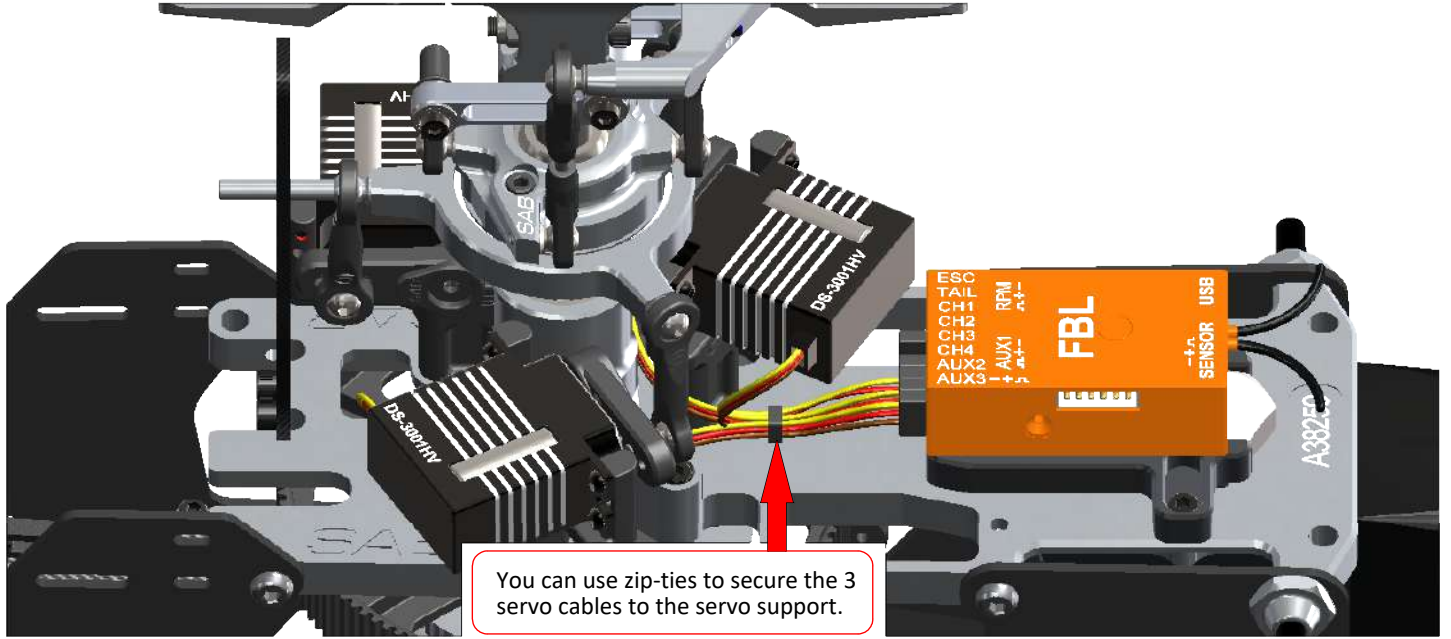

HPS Head Preliminary Setup

Linkage Rod A Assembly ... x2



Linkage Rod M2x22mm (H0561-S)

Initial length for the rods from the swashplate to the blade grips.

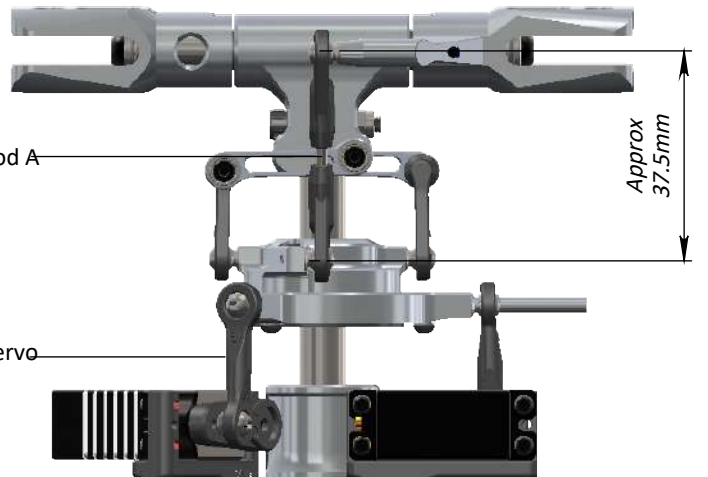

Linkage Rod A Assembly

Linkage Servo (H0524-S)

The distance between the servo spline and the ball must be between 13-15 mm
You can use the SAB servo horn [HA053].



Uniball M2 Ø5H6 (H0064-S) Socket Head Cap M3x6mm (HC044-S)

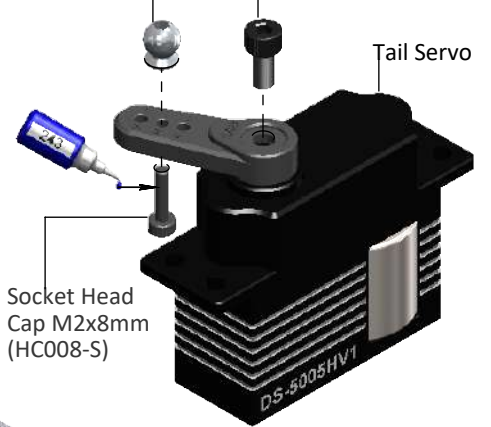

Socket Head Cap M2x8mm (HC008-S)

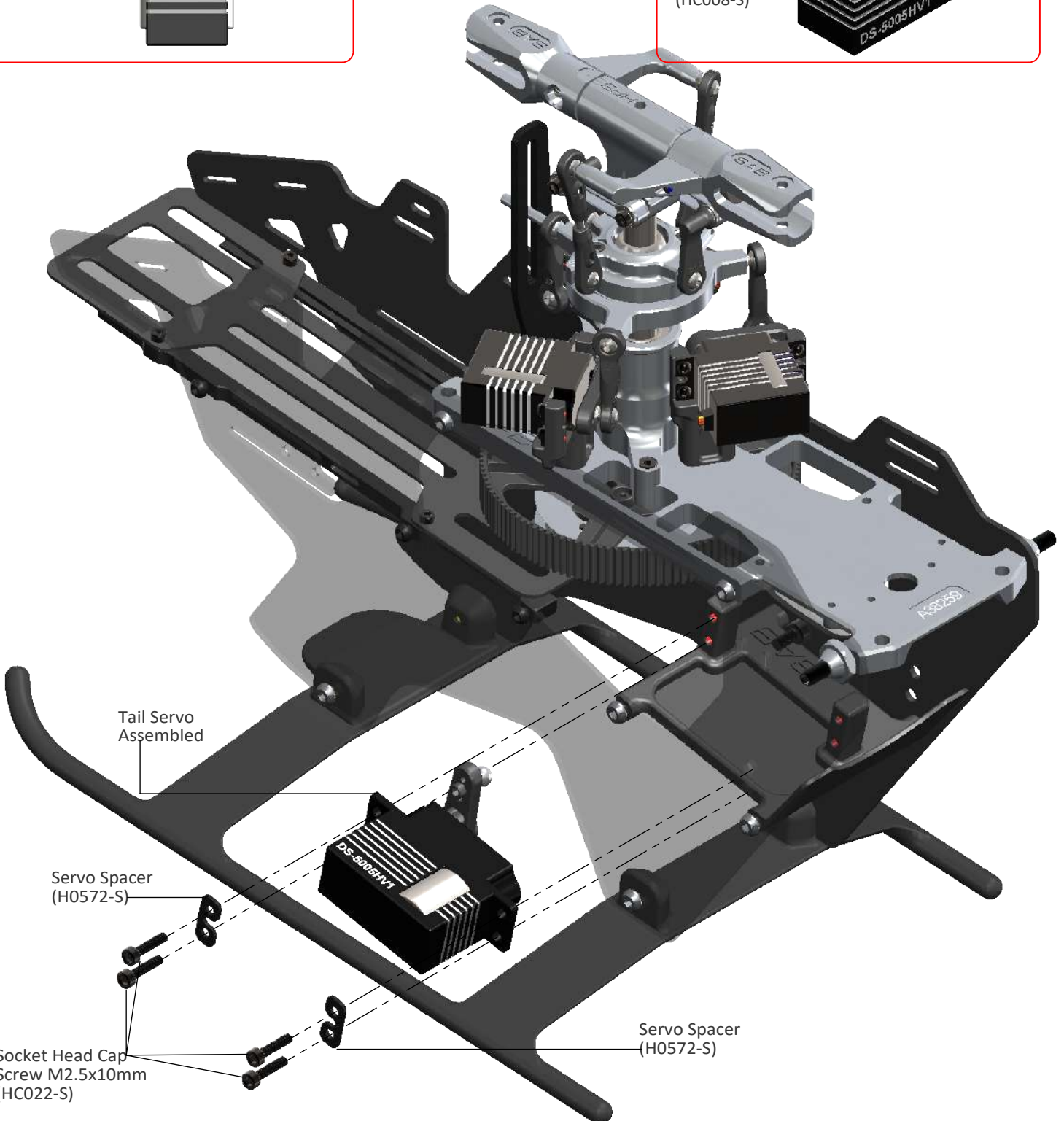

TRANSMISSION SETUP

It is important to choose the right reduction ratio to maximize efficiency based on your required flight performance. It is possible to optimize any motor and battery combination. It is recommended to use wiring and connectors appropriate for the currents generated in a helicopter of this class.

If you are using a head speed calculator which requires a main gear and pinion tooth count, use **120** teeth for the main gear and the tooth count of your pulley as the pinion count.

Below is a list of available reduction ratios:

H0501-19-S - 19T Pinion = ratio 6.3:1	H0501-22-S - 22T Pinion = ratio 5.5:1
H0501-20-S - 20T Pinion = ratio 6:1	H0501-23-S - 23T Pinion = ratio 5.2:1
H0501-21-S - 21T Pinion = ratio 5.7:1	H0501-24-S - 24T Pinion = ratio 5:1

The Goblin 380 accepts a wide selection of batteries with different capacities. The suggested number of cells is 6.

All batteries from 1500 to 2600 mAh offer good performance.

We recommend the use of an 1800 mAh battery for the perfect compromise between weight and performance (3D flight). Larger capacity batteries (2200-2600) increase flight times at the expense of weight and reduced agility (Sport flight).

Some example configurations:

CONFIGURATION

Motor	ESC	Motor Pulley	RPM Max	Pitch
Scorpion HK 3014-900	CC Lite 75	23T	3300	±12.5
	Koby 70 - YGE 65	21T	3300	
X-NOVA 2820-890	CC Lite 75	24T	3400	±12.5
	Koby 70 - YGE 65	22T	3400	
Scorpion HK 3020-1000	CC Lite 75	22T-23T	3400-3550	±12.5
	Koby 70 - YGE 65	19T-20T	3400-3550	
	CC Lite 100	22T-23T	3550-3700	
	Kolibri 90 - YGE 95, HW80	20T-21T	3550-3700	
KDE 500XF 925-G3	CC Lite 75	23T-24T	3400-3550	±12.5
	Koby 70 - YGE 65	21T-22T	3400-3550	
	CC Lite 100	24T-25T	3550-3700	
Kontronik Pyro 380-9				
X-NOVA 3215-930	Kolibri 90 - YGE 95, HW80	22T-23T	3550-3700	

 **Note:** Although the Goblin can handle even higher RPMs, for safety reasons we suggest to not exceed 3600 RPM.

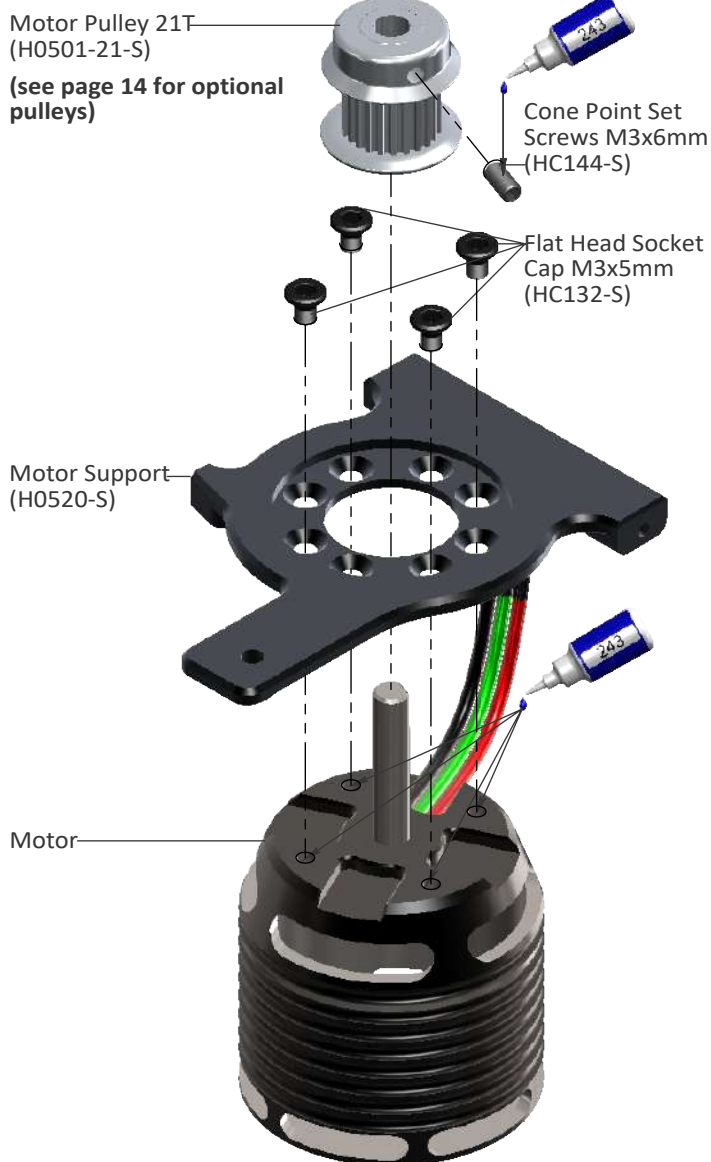

NOTE:

Correct position for the motor wires.



Motor

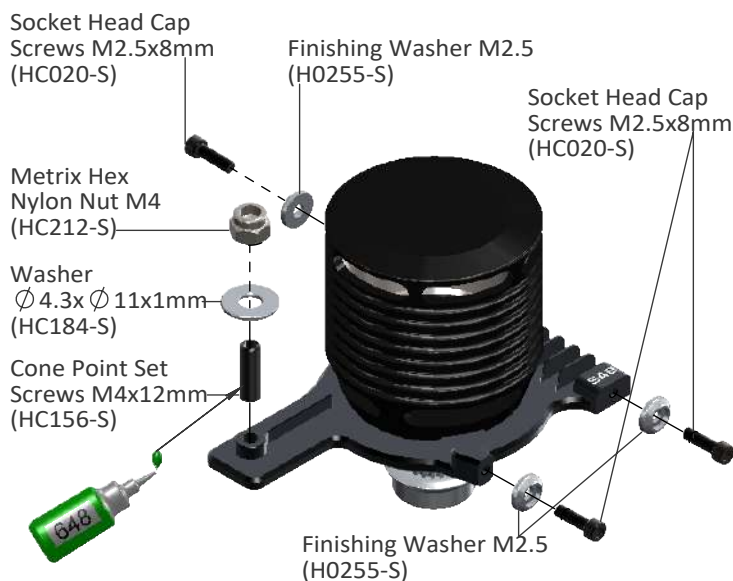

NOTE:

To maximize space for the batteries, it is advisable to shorten the motor shaft. Follow the dimensions given in this drawing. For the cut, you can use an electric tool like a "Dremel" with a cutoff disc.

Additionally, ensure the motor shaft has an appropriate 'flat' for one of the set screws.

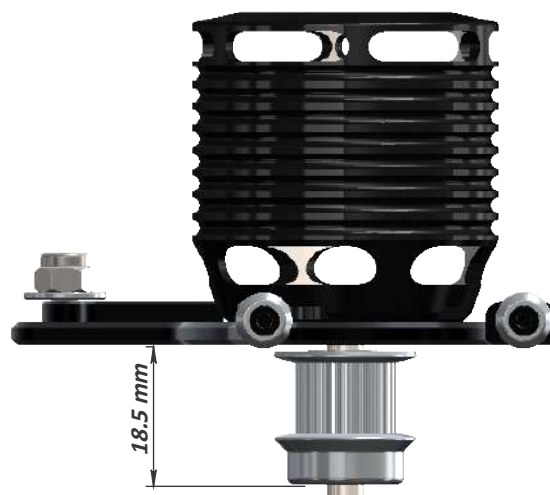

MOTOR BELT TENSION

- *Assemble the motor and pulley to its mounting plate.
- *Install the motor assembly in the helicopter.
- *It is easy to install the belt with the motor assembly pushed back towards the helicopter as far as it can go.
First put the belt on the motor pulley.
- *Then put the belt around the big pulley.
- *Rotate the motor several times by hand.
- *Pull and hold the motor slightly.
- *Tighten the M4 nut first (It is suggested to use tool nut driver).
- *The belt must be very tight.
- *Tighten the rest of the bolts.

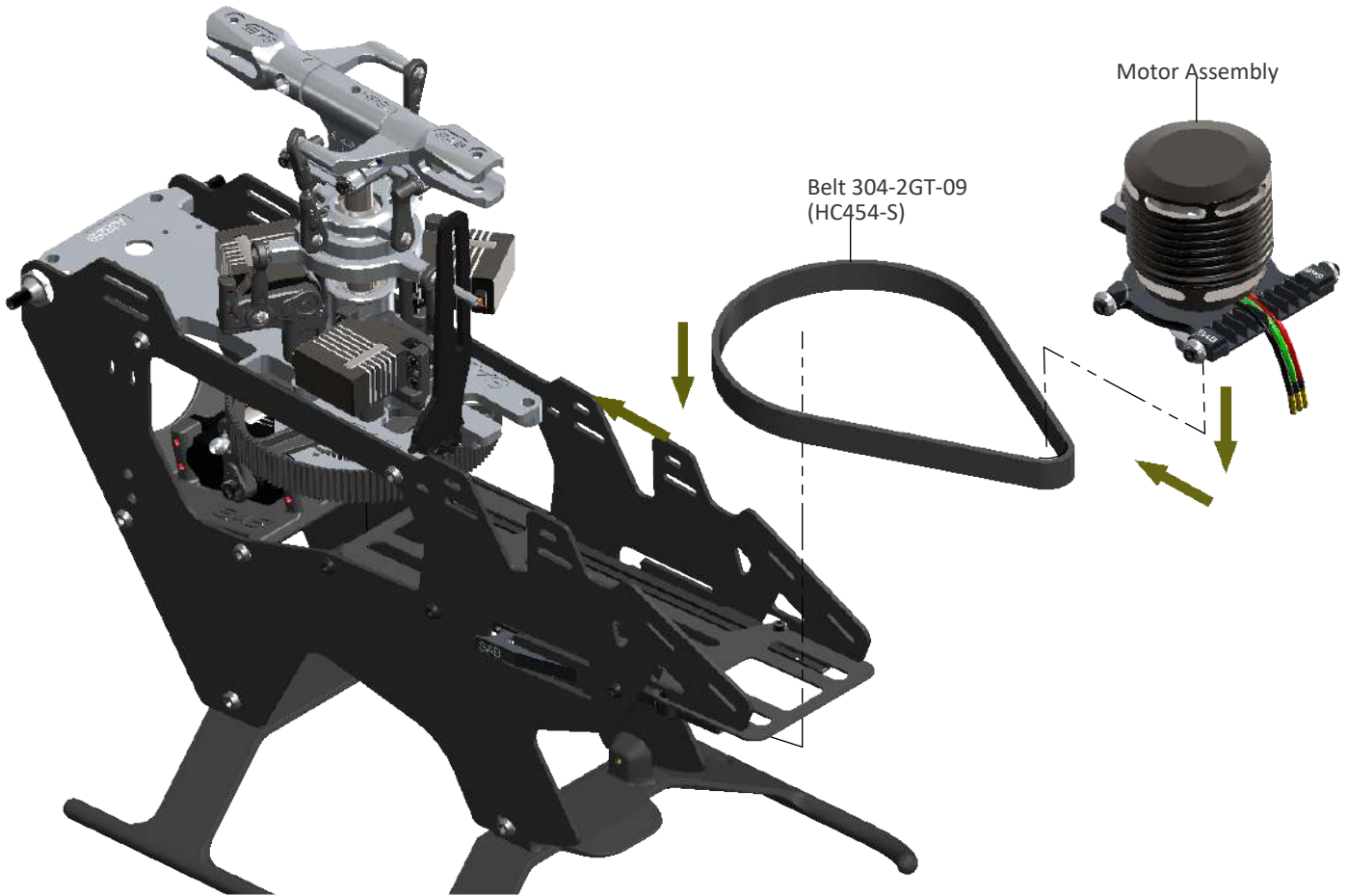

Note:

Check for vertical alignment of the motor pulley. To do this, simply turn the motor several times by hand and check to you see if the belt is aligned properly with the big pulley (one way bearing pulley).

If the belt is riding too high, simply loosen up the motor pulley and drop it just a little bit, if it is riding too low, loosen up the motor pulley and raise it a bit.

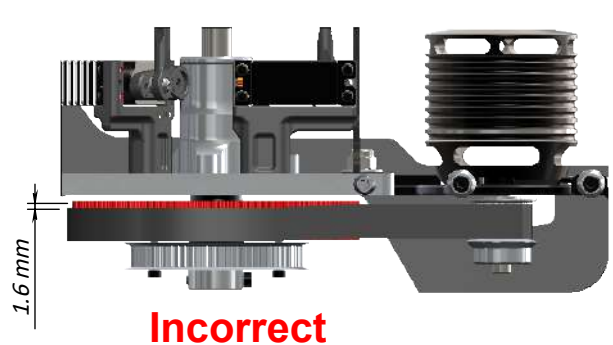
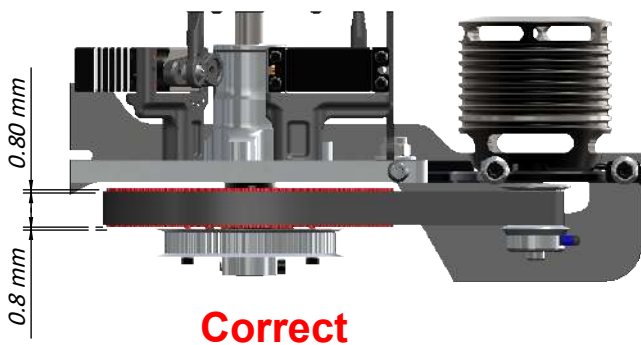

DE-BURR THE SIDE FRAMES

We recommend de-burring the edges of the carbon parts in areas where electrical wires run. (See Page 4).

**ESC INSTALLATION**

The speed controller (ESC) is installed in the front of the helicopter.

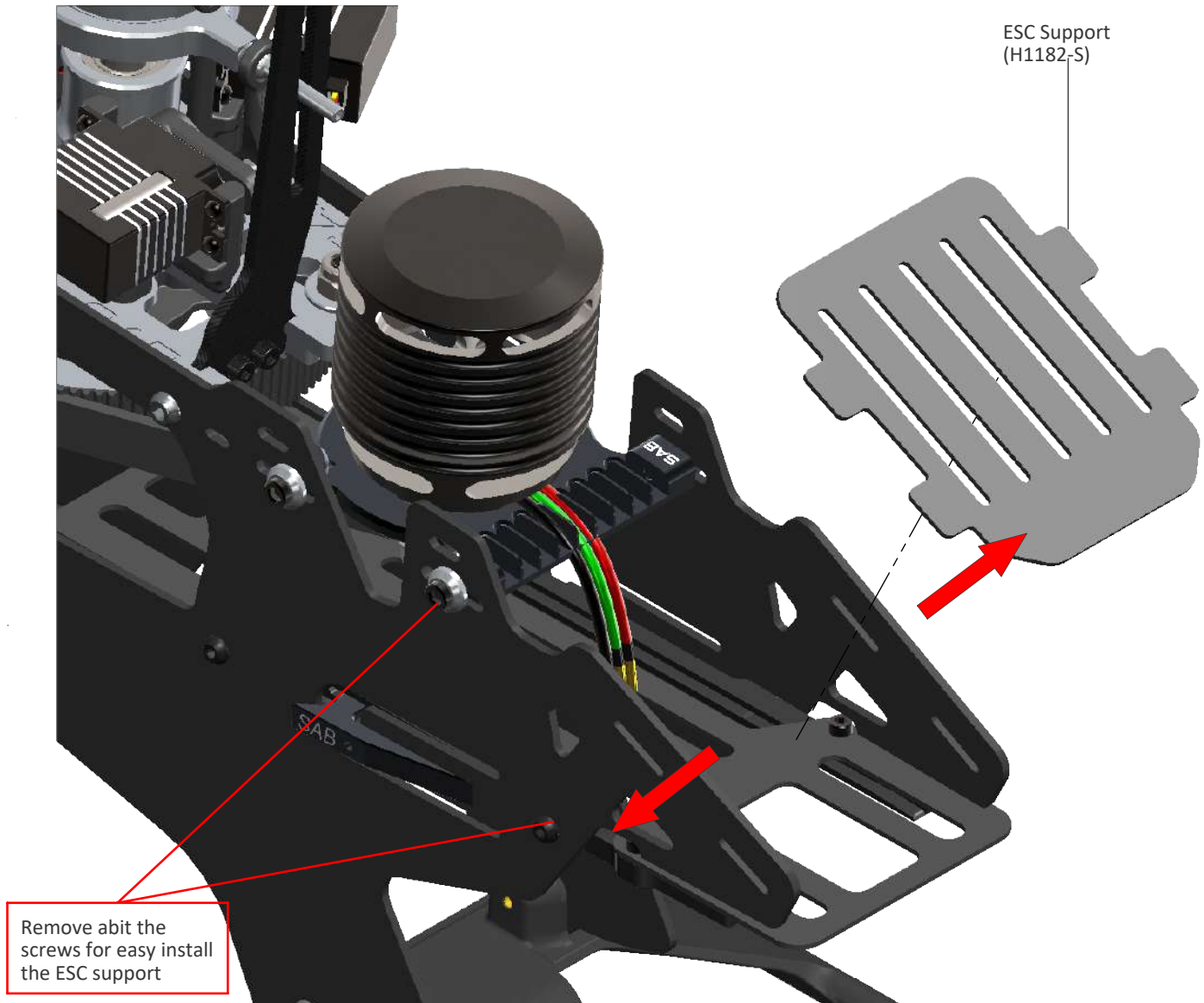

Figure Shows the ESC installed.



FLYBARLESS CONTROL UNIT AND RX INSTALLATION

We suggest the use of a “single unit” FBL system (all in one type unit). This allows for easier wire routing considering the small size of this helicopter.

Position 1 can be used to install the FBL unit.
Position 2, 3 and 4 can be used to install a small RX unit or satellite.

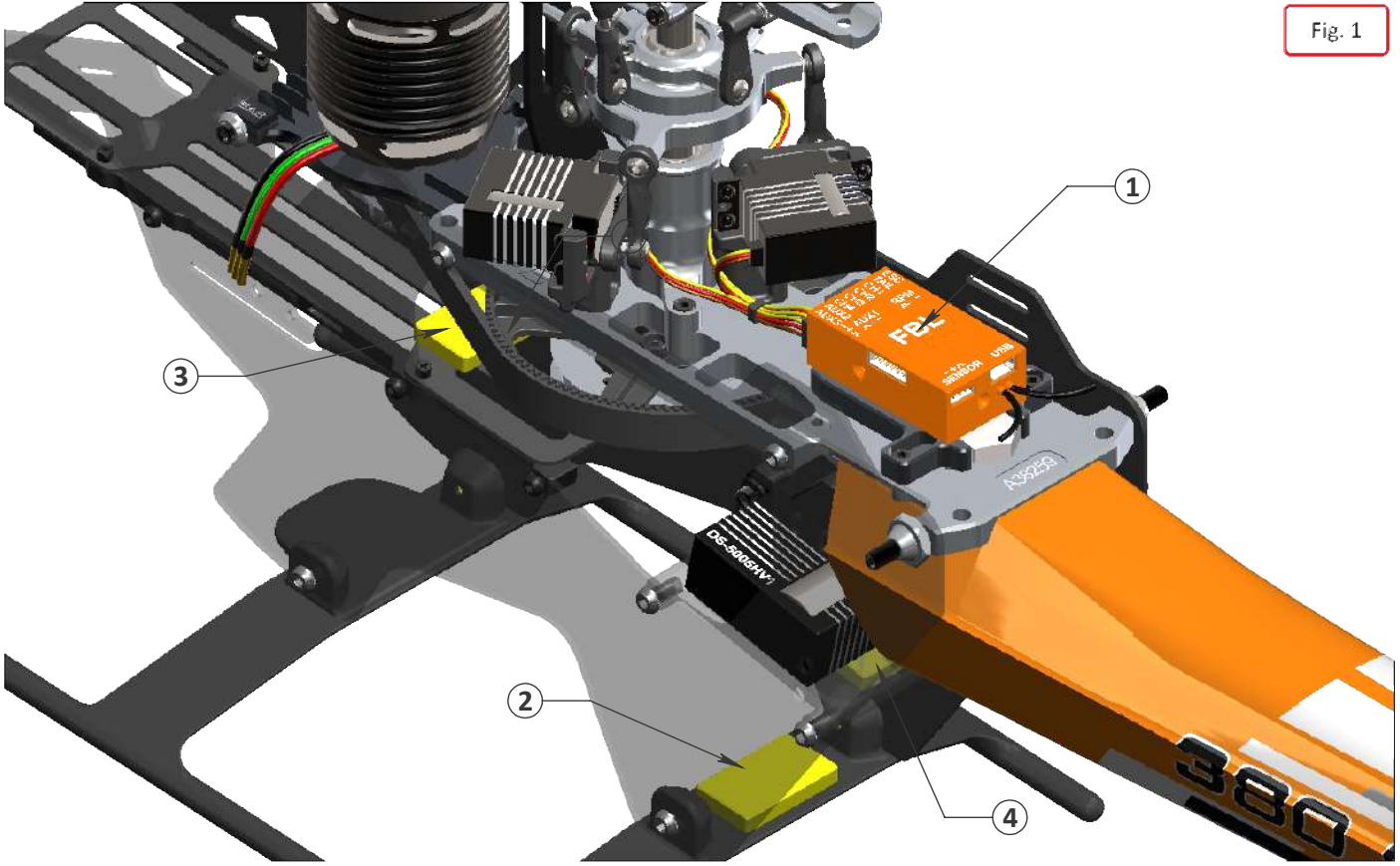

Fig. 1

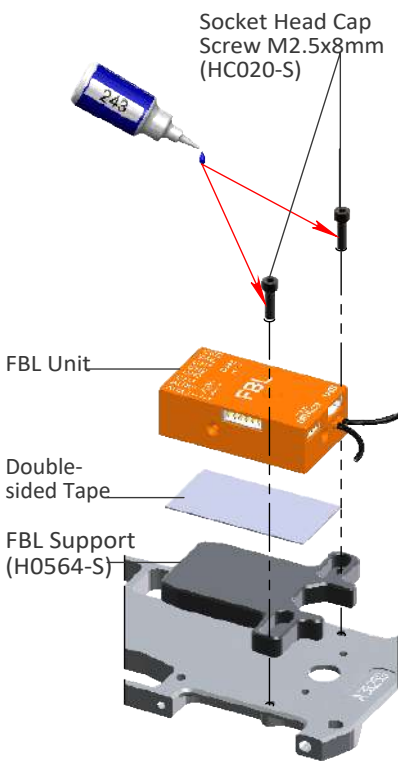

Fig. 2 shows the unit mounted on the support H0564.
Fig. 3 shows the unit directly mounted on the main aluminum plate.

Use your judgment to decide whether you need to install your FBL unit as shown in Fig 2 or Fig 3. This will depend on the size of the FBL unit itself and the arrangement of the wires.

With larger units, the nylon nut can make it difficult to connect the wires to the unit, in this case it is recommended to use the aluminum support H0564.

With smaller units, the unit can be installed directly onto the main plate. This facilitates boom removal in the future if necessary.

We recommend using some type of adhesive to prevent the servo wires and connections from coming unplugged from the receiver or FBL unit. You can use hot glue for this purpose.

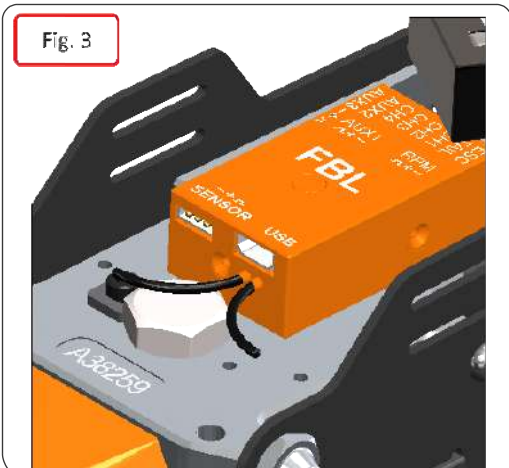
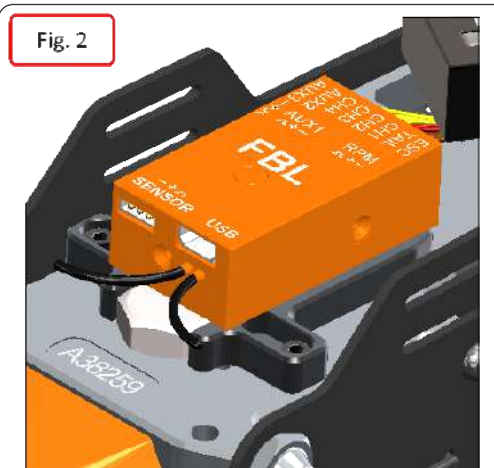
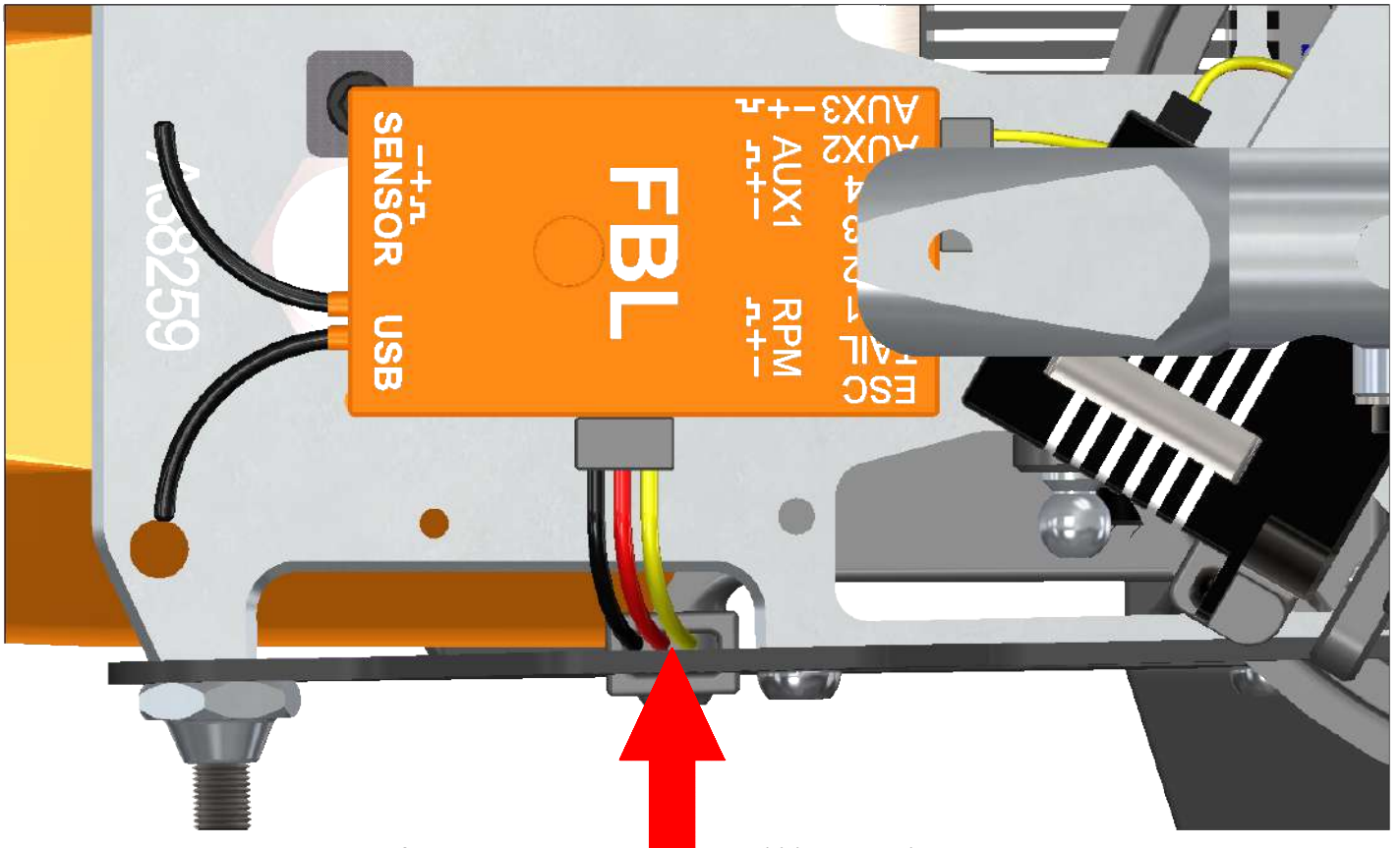

Fig. 4



The area between the boom and the frame can be used to route the wire(s) (Fig 4 and 5).

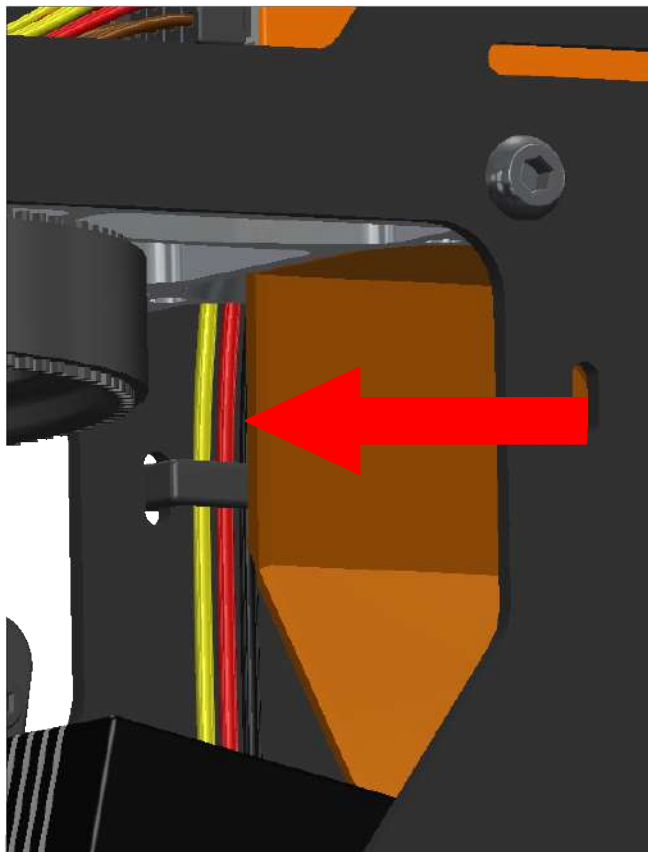

Fig. 5

You can secure the wire(s) to the frame with zip-ties (Fig6).

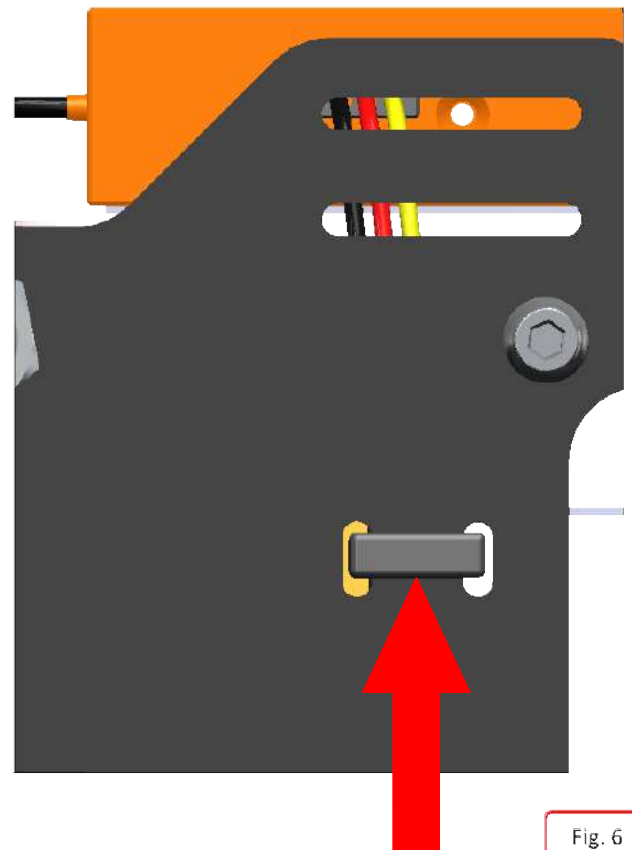
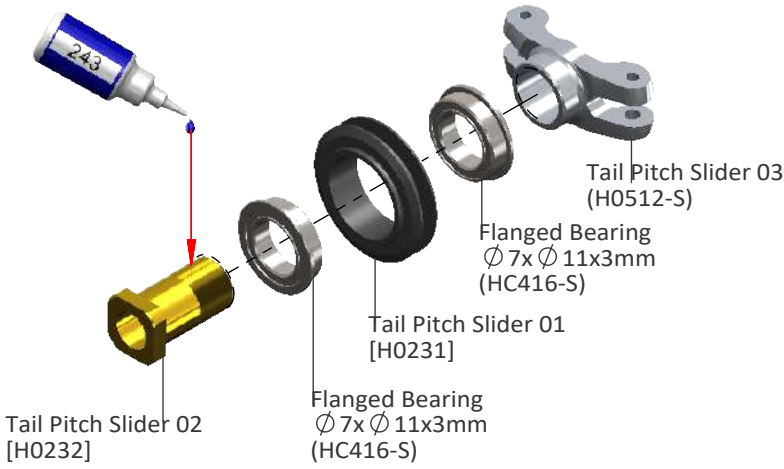

Fig. 6



Tail Pitch Slider Assembly

Already Assembled



Tail Rotor Hub Assembly

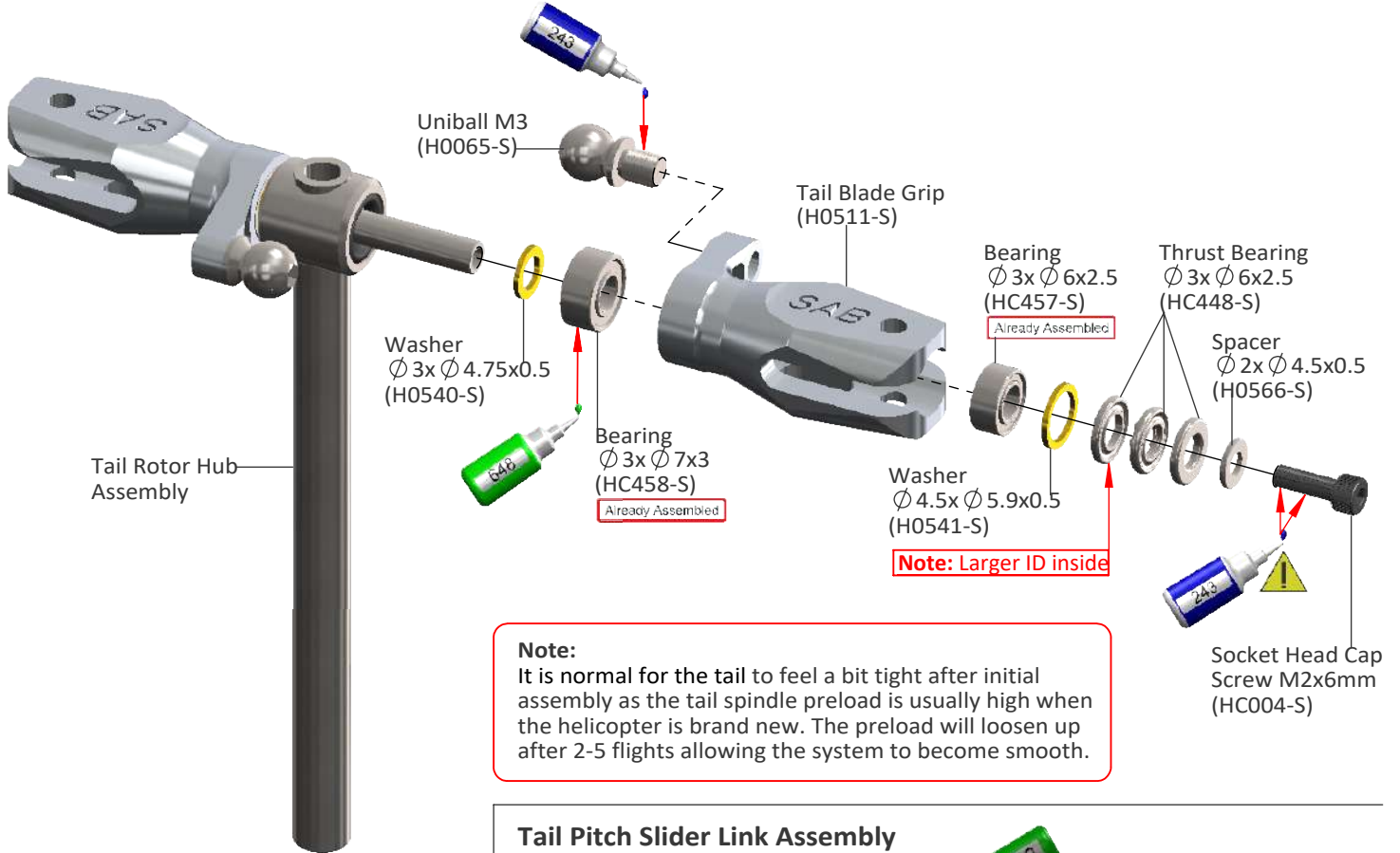
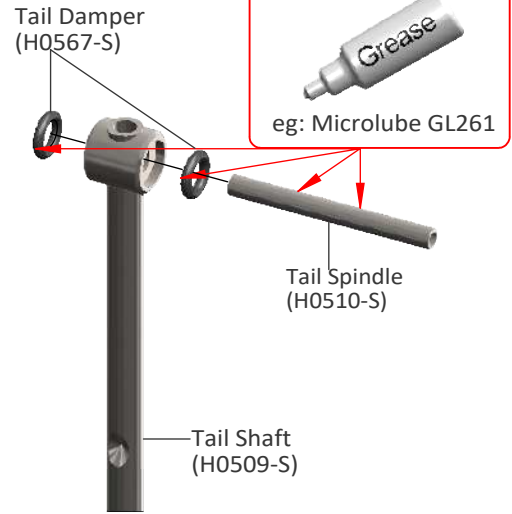

Tail Pitch Slider Link Assembly

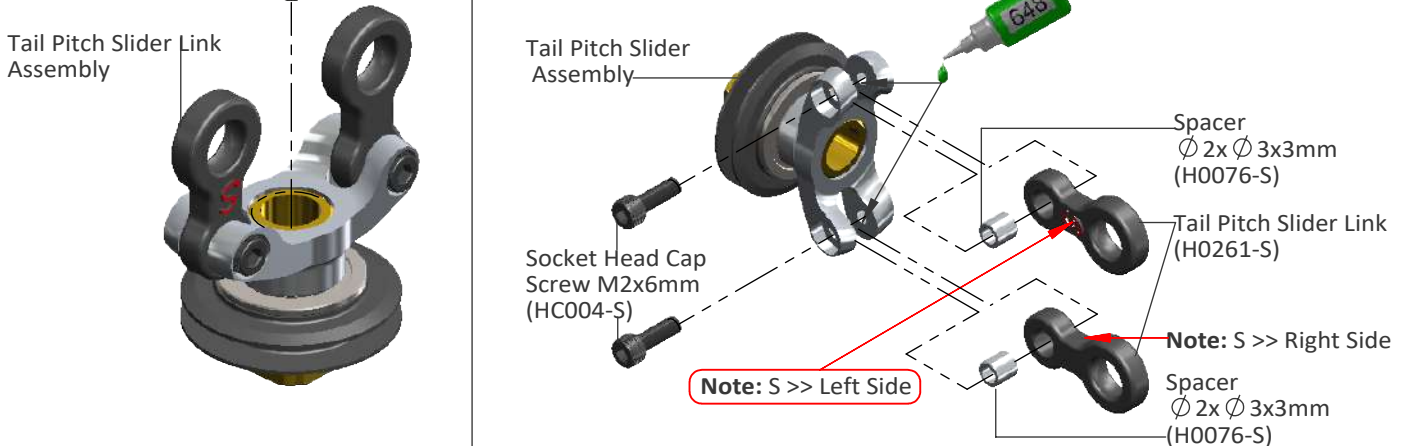

Tail Side Plate Assembly

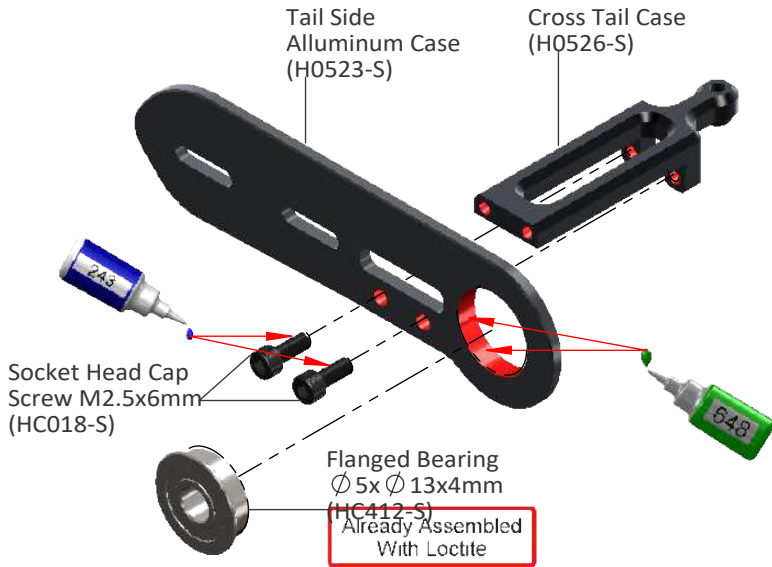

Bell Crank Lever Assembly

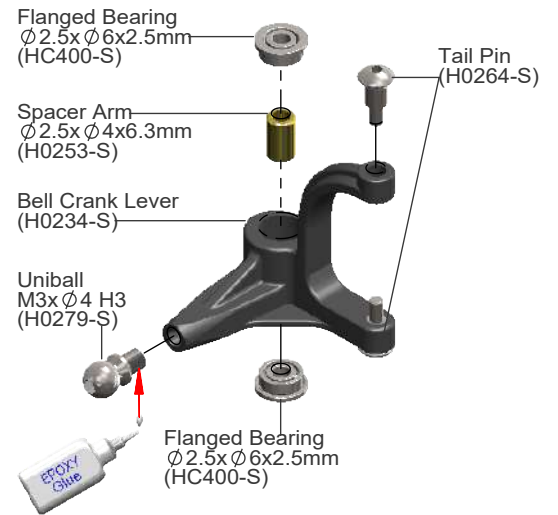

Tail System Assembly

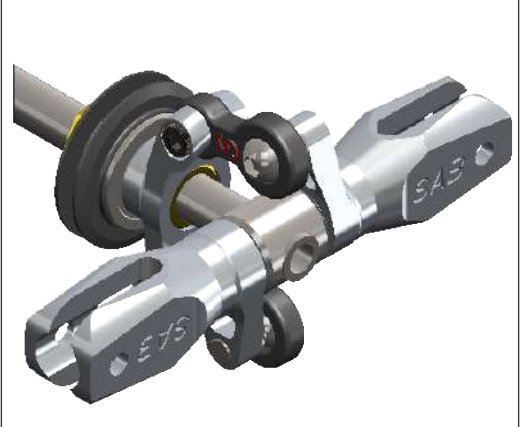
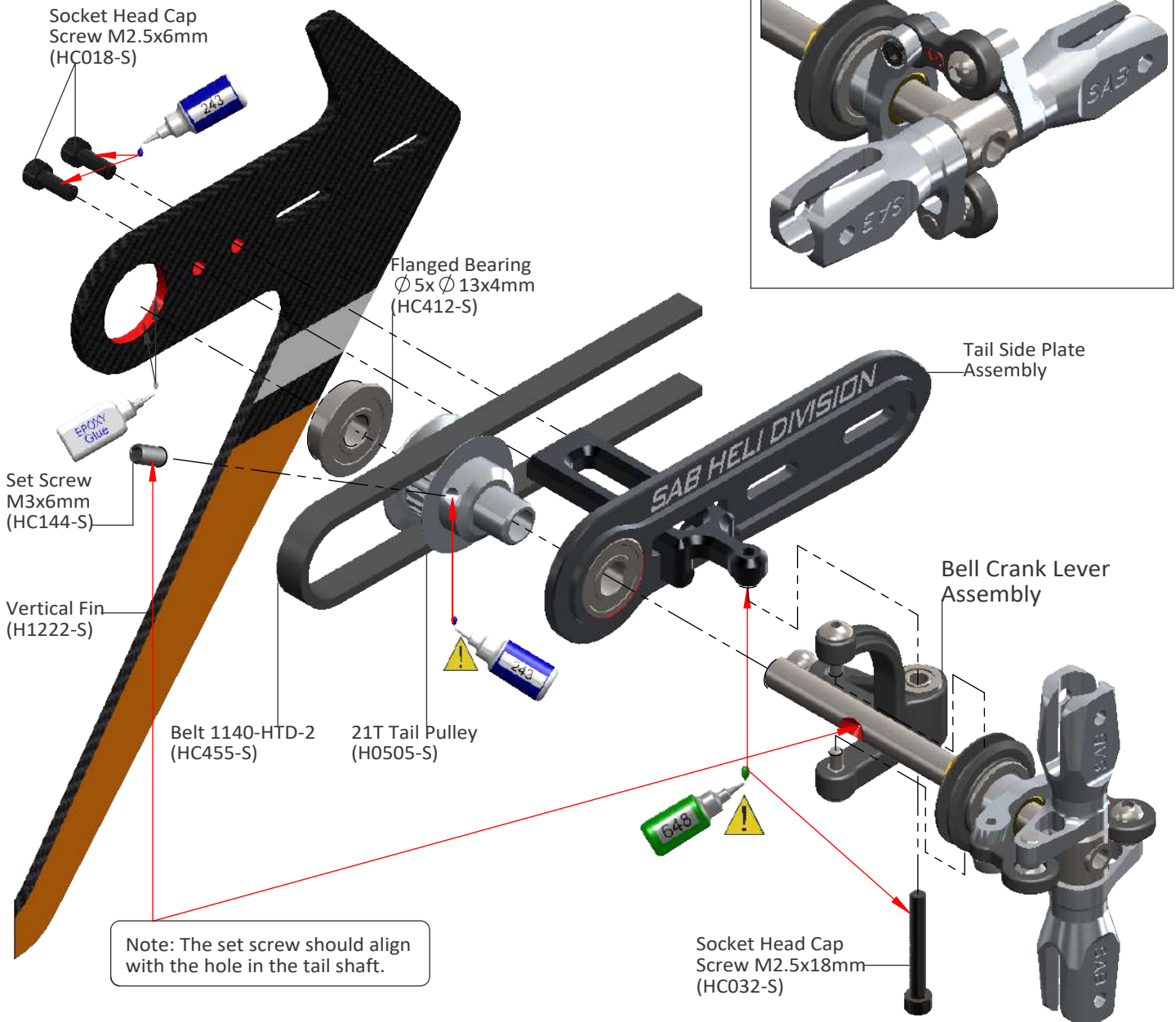

Note: We suggest to clean the sticking surface with sand paper.

Locking Element Tail Assembly x 2

Locking Element Tail
(H0535-S)

Already Assembled

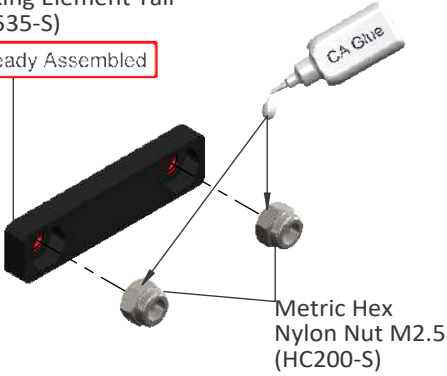

Tail Boom Assembly

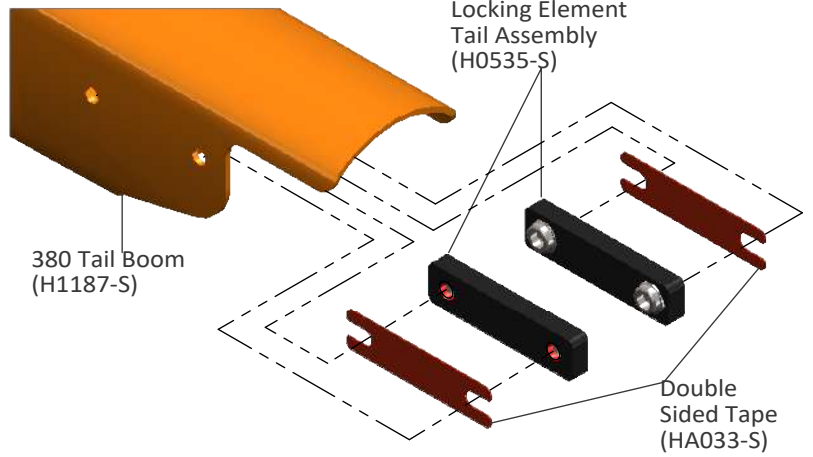

M8 Carbon Block Assembly

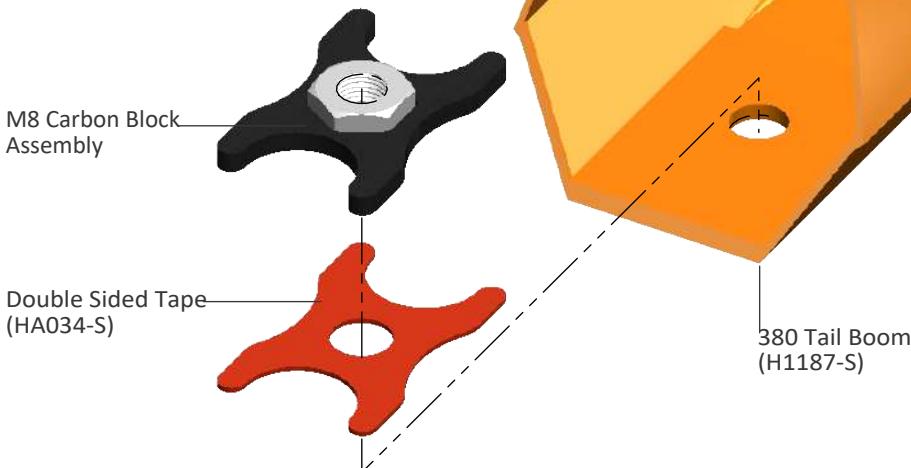
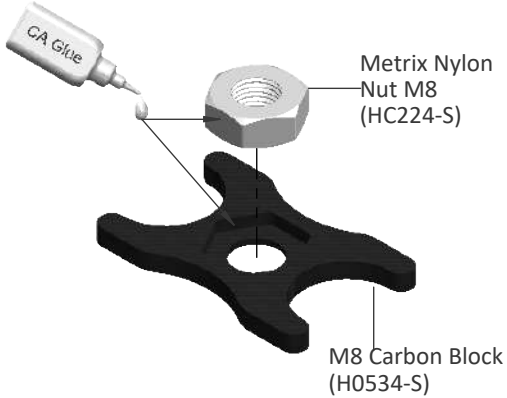

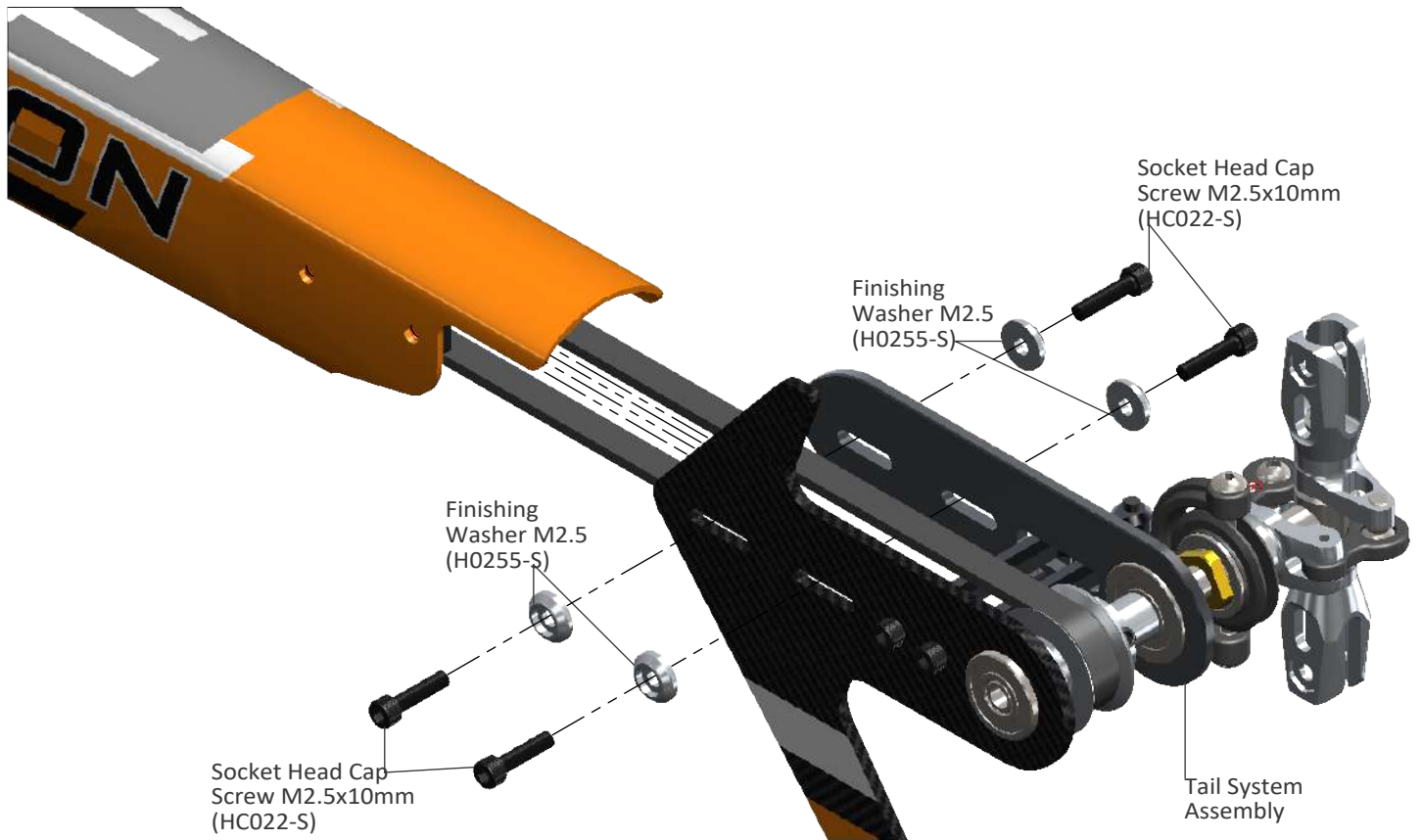

Note: Please allow plenty of time for the glue to cure before inserting plastic ball link onto the threaded rod.

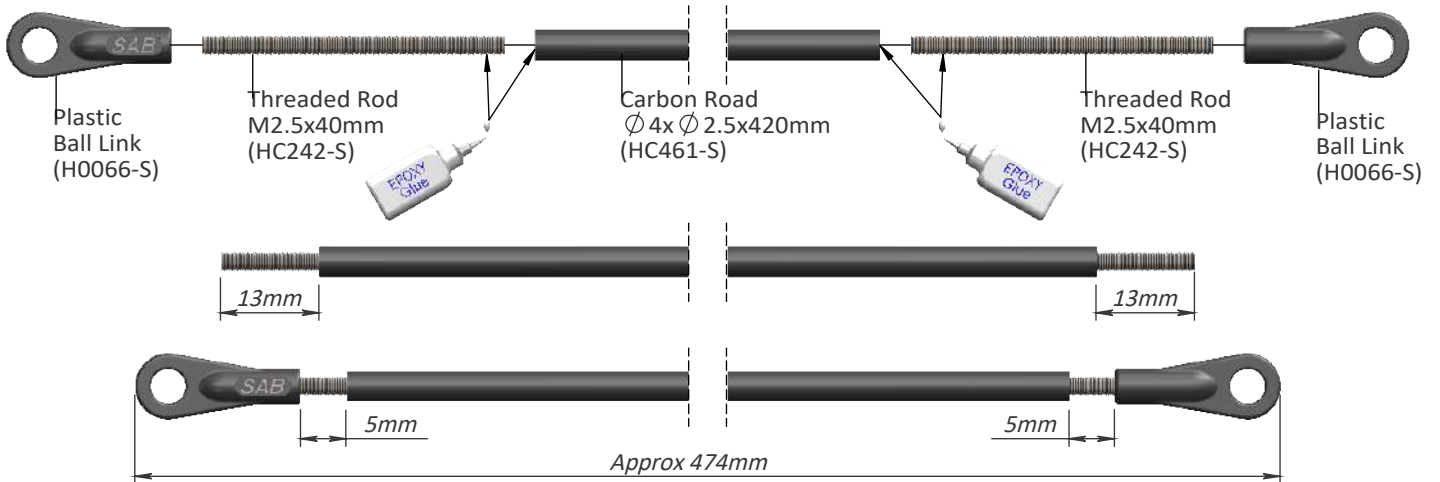

BOOM ASSEMBLY

- * Insert the boom. This operation is easier fitting into the main frame at a slight angle [Fig.1].
- To facilitate boom insertion, you can also unscrew the two bolts that hold the tail servo support tray.
- * Tighten the M8 nut with HA016 special tool supplied.
- * After installation, connect the tail push rod.
- * To lock the nut and prevent it from coming loose, install:
 - H0287 (for FBL unit installed on the main plate) [Fig.2].
 - H0564 (for FBL unit installed on H0564) [Fig.3].

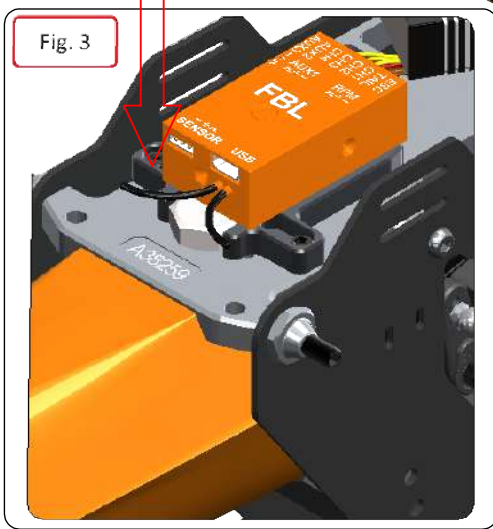
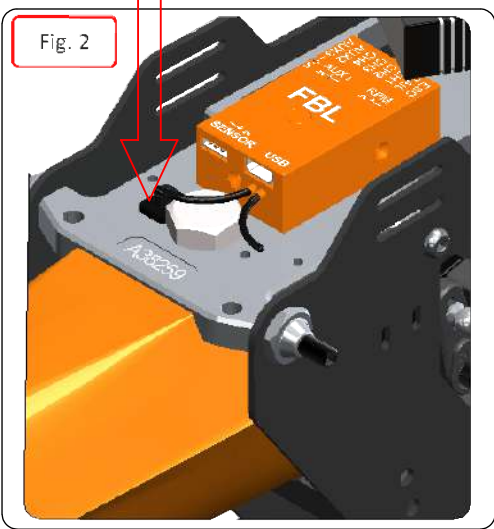
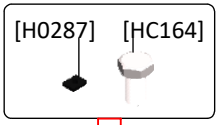
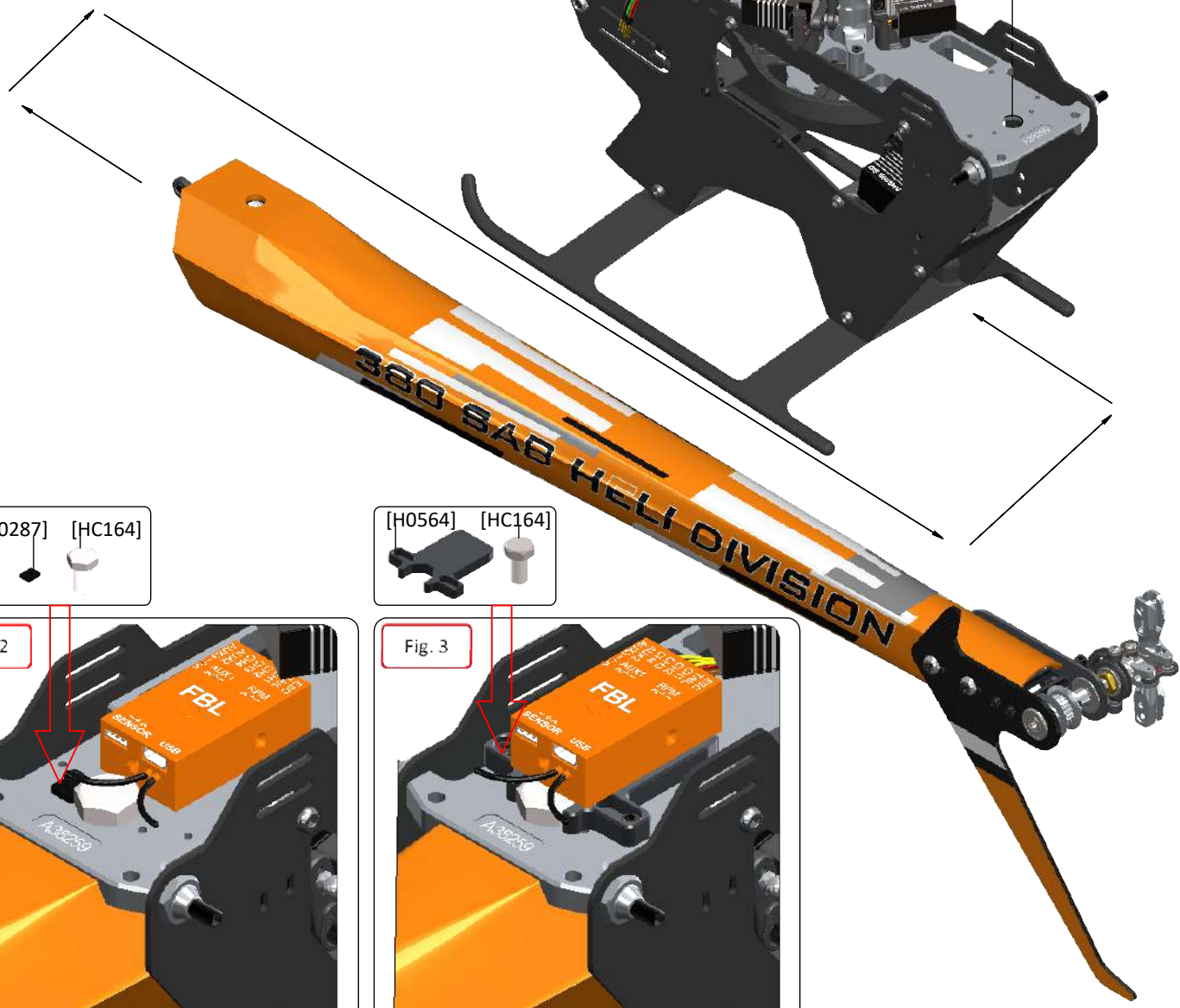
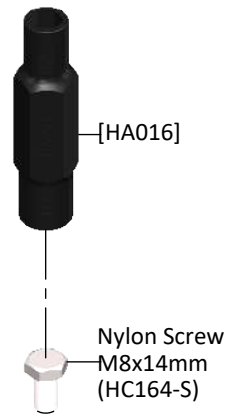
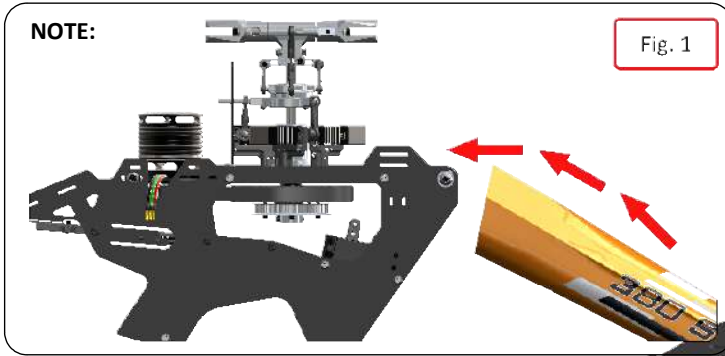

TAIL BELT TENSION

- *Check for the proper assembly of the tail boom.
- *Loosen the tail case by loosening the 4 M2.5 screws.
- *Install the belt onto the front pulley in the correct direction of rotation (figure 1).
- *Rotate the tail drive several times by hand.
- *Pull the tail case back to increase belt tension.
- *Tighten the 4 M2.5 screws on the tail case.
- *The belt must be very tight.

Fig. 1



CANOPY

Fit the canopy to the main frame until it stops. [Fig. 2]
Fit the canopy holes to the M4 set screws on the model.

Check alignment of the edge on the boom [Fig. 3]
If the alignment is correct, enlarge the 2 canopy holes with a reamer up to 10 mm in diameter.
If alignment is not OK, enlarge the 2 canopy holes in the appropriate direction up to 10 mm in diameter.

Install the canopy grommets. [Fig. 4]

The canopy can be locked using the knobs H0543. [Fig. 5]

NOTE: If you want to use the rubber edge protector, you must increase the size of the opening in the canopy that goes around the anti-rotation guide by approximately 2 mm per side.

Fig. 5

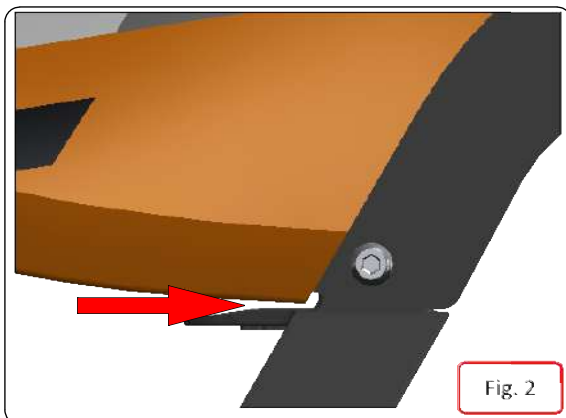
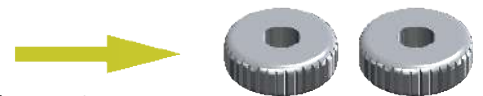

Fig. 2

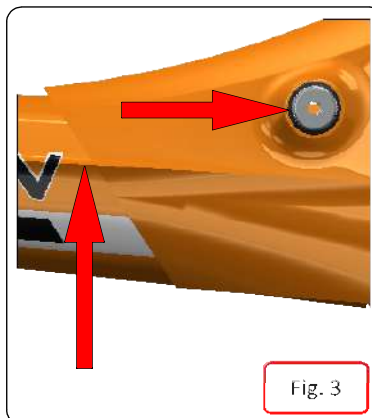

Fig. 3

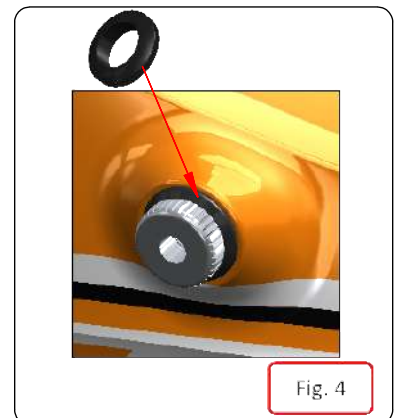

Fig. 4

BATTERIES

The Goblin has a quick release battery tray system.

The batteries must be installed onto the battery tray to take advantage of the quick release locking system.

Install the battery to the battery tray using double sided tape and the long Velcro straps included (Fig 1 and Fig 2).

Make sure to find the right position of the battery to optimize the center of gravity.

The battery wires arranged as in fig 2 are particularly effective.

To insert the battery, simply align the battery tray in the slots at the front of the helicopter and slide all the way. The battery will lock in place.

To remove the battery, simply lift up on the locking lever (Fig 5) and pull.

IMPORTANT:



Make sure the battery is locked in place before flight; the battery tray must be inside the slots on both sides!

Fig. 1

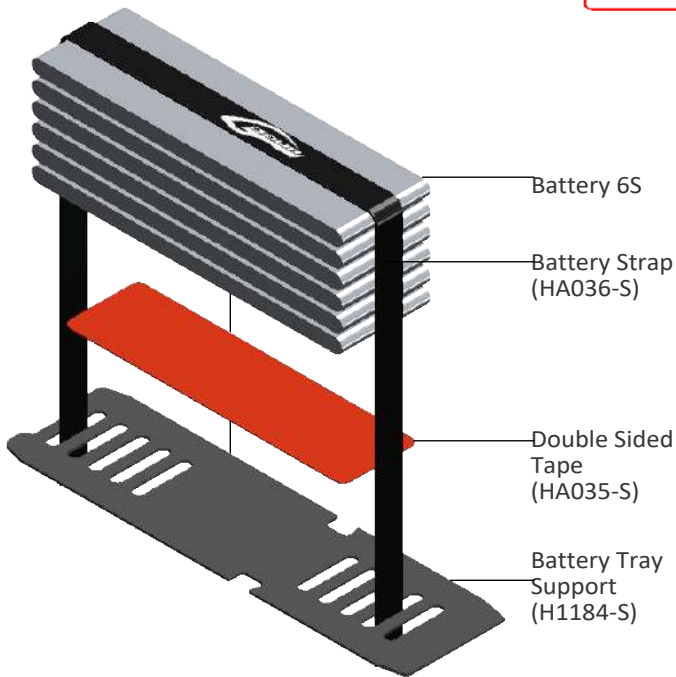

Fig. 2



Fig. 3

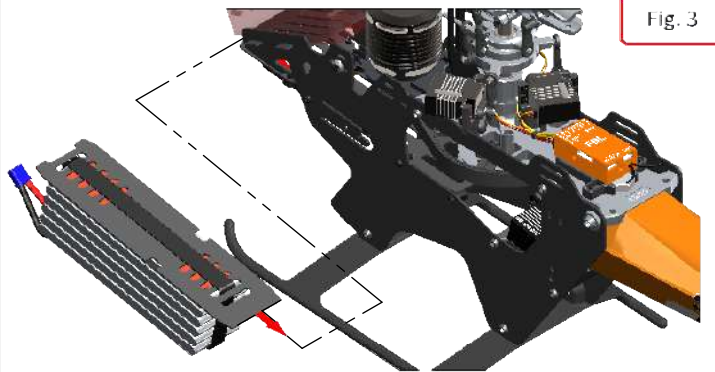

Fig. 4

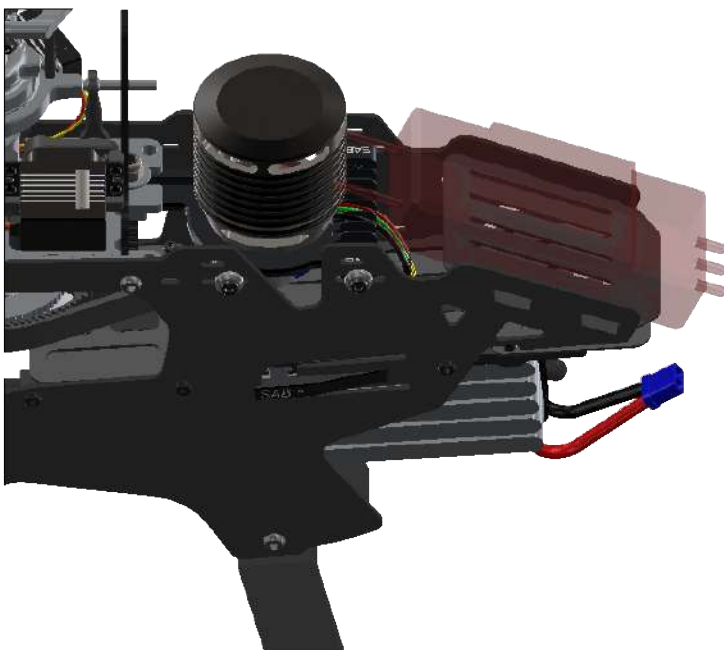
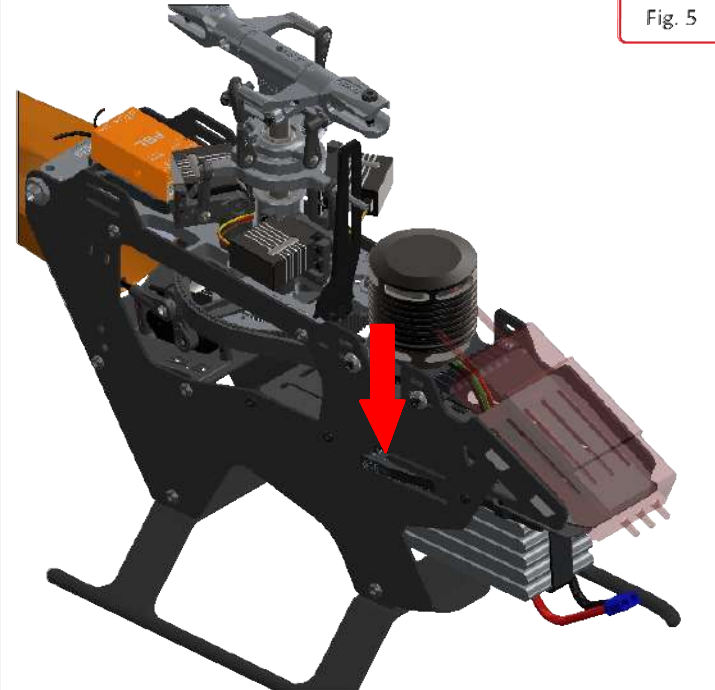

Fig. 5



OPERATIONS BEFORE FLIGHT

*Set up the transmitter and the flybarless system with utmost care.

*It is advisable to test the correct settings of the transmitter and flybarless system without main blades and tail blades fitted.

*Check that all wiring is isolated from the carbon/aluminum parts. It is good practice to protect them at the points where they are at most risk.

⚠ *Be sure of the gear ratio, verifying carefully the motor pulley in use. The forces acting on the mechanics increase enormously at higher RPM. Although the Goblin can fly at very high RPMs, for safety reasons we suggest to not exceed 3600 RPM.

*Fit the main blades and tail blades. (Fig.1 and Fig.2)

*Please make sure the main blades are tight on the blade grips, you should be able to violently jerk the head in both directions and the blades should not fold. Failure to tighten the blades properly can result in a boom strike during spool up. To fold the blades for storage, it is advisable to loosen them.

*Check the collective and cyclic pitch. For 3D flight, set about +/- 12.5°.

*It is important to check the correct tracking of the main blades. (Fig 3).

⚠ *Perform the first flight at a low head speed, 2500/2600 RPM. After this first flight, do a general check of the helicopter. Verify that all screws and bolts are correctly tightened.

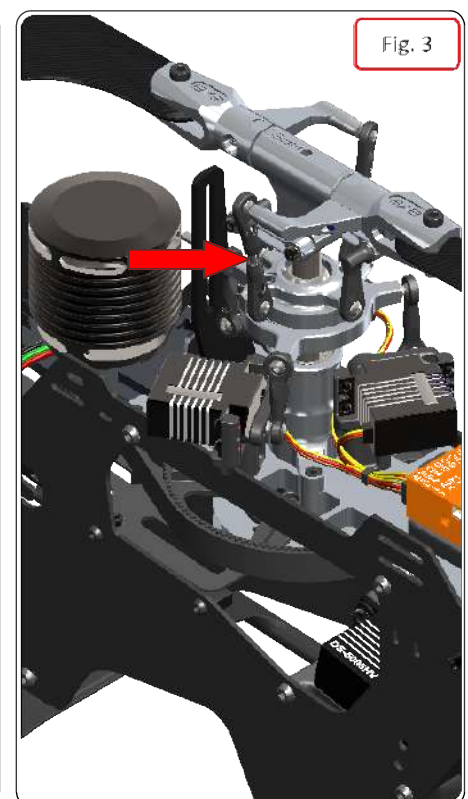
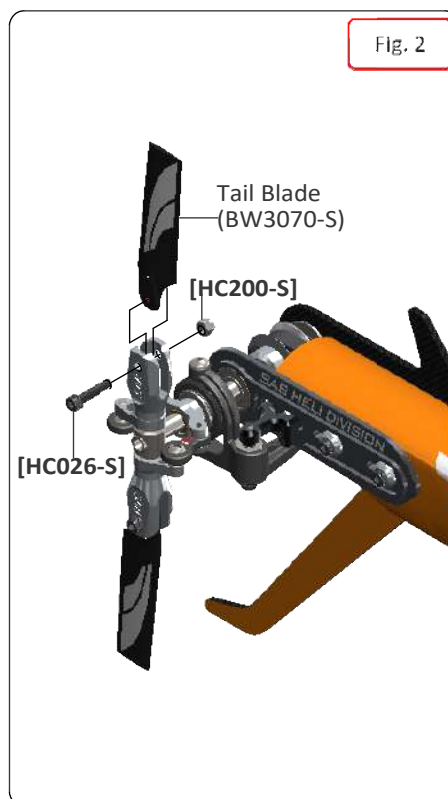
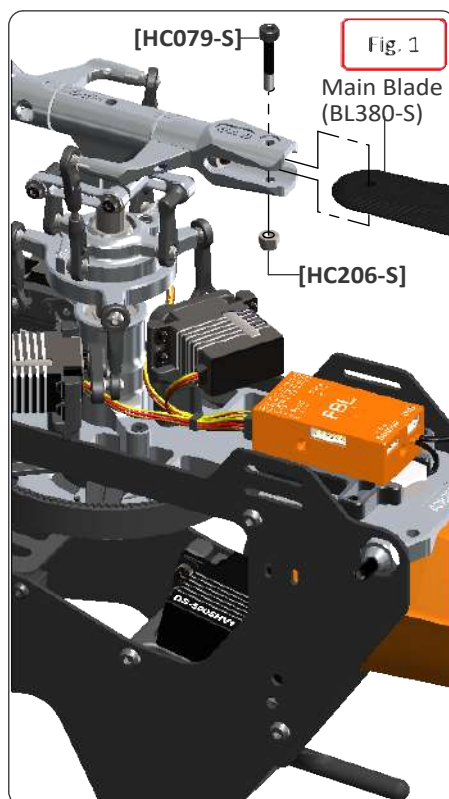

IN FLIGHT

It's very important to check the model thoroughly after the first 2-3 flights. Check all bolts, screws, belts, ball links, etc.

If the model is making strange noises, this can be usually attributed to incorrect belt tensions. Check the belts again and tighten if necessary.

MAINTENANCE

*On the Goblin 380, some areas to look for wear include:

- Motor belt
- Tail belt
- Dampers

*The most stressed bearings are definitely those on the tail shaft and the thrust bearings. Check them frequently. All other parts are not particularly subject to wear.

Fig. 1

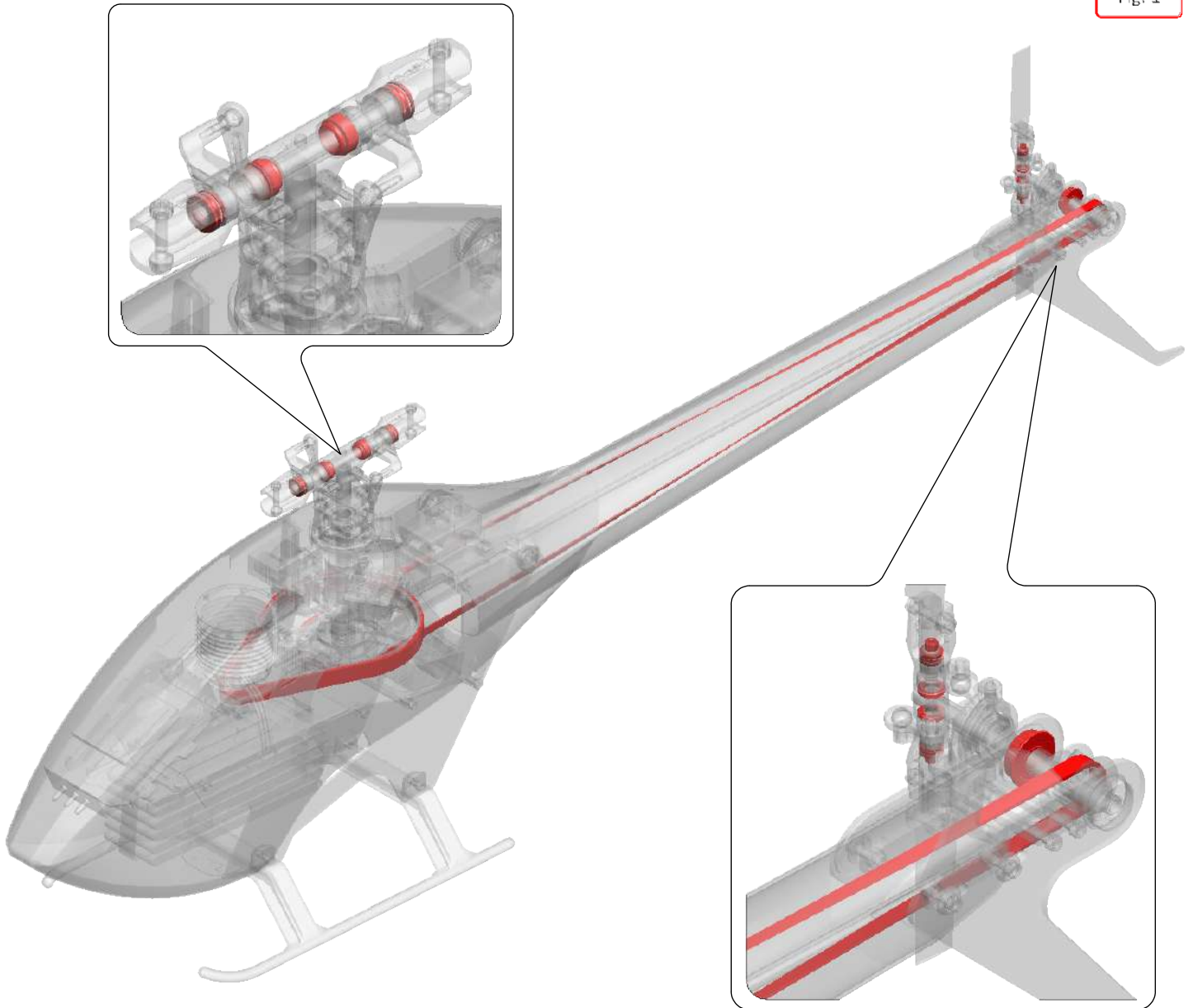



















*The lifespan of these components varies according to the type of flying. On average it is recommended to check these parts every **20** flights. In some instances, based on wear, these parts should be replaced every **100** flights.













*Periodically lubricate the tail slider movement and its linkages as well as the swash plate movement and its linkages.

*To ensure safety you should do a general inspection of the helicopter after each flight. You should check:

- Proper belt tension (motor belt and tail belt).
- Proper isolation of the wires from the carbon and aluminum parts.
- All screws and bolts remain tight.





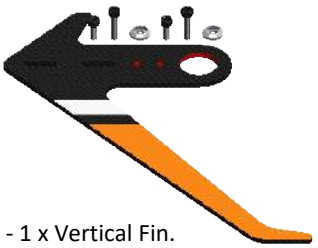























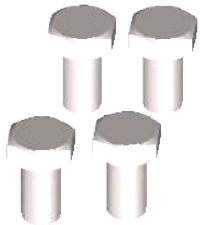





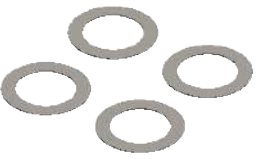
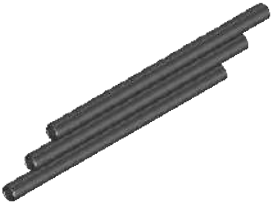













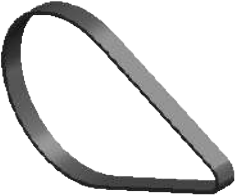



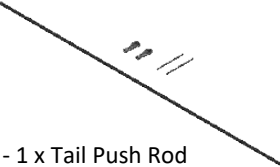

<p>Uniball M2 ϕ 5H6 [H0064-S]</p>  <ul style="list-style-type: none"> - 5 x Uniballs M2 ϕ 5H6. - 5 x Uniball Spacers. - 5 x Socket Head Cap Screws M2x8mm. - 5 x Socket Head Cap Screws M2x6mm. 	<p>Uniball M3x4 ϕ 5H3 [H0065-S]</p>  <ul style="list-style-type: none"> - 5 x Uniballs M3x4 ϕ 5H3.5. 	<p>Plastic Ball Link [H0066-S]</p>  <ul style="list-style-type: none"> - 10 x Plastic Ball Link. 	<p>Bell Crank Lever [H0234-S]</p>  <ul style="list-style-type: none"> - 1 x Bell Crank level. - 2 x Tail Pin. - 2 x Flanged Bearing ϕ 2.5x ϕ 6x2.5mm. - 1 x Spacer Arm ϕ 2.5x ϕ 4x6.3. - 1 x Head Cap Screws M2.5x18. - 1 x Uniball M3x ϕ 4 H5.
<p>Finishing Washer M2.5 [H0255-S]</p>  <ul style="list-style-type: none"> - 10 x Finishing Washer M2.5. 	<p>Tail Pitch Slider Link [H0261-S]</p>  <ul style="list-style-type: none"> - 2 x Tail Pitch Slider Link. - 2 x Spacer ϕ 2x ϕ 3x3mm. - 2 x Socket Head Cap M2x6mm. 	<p>Plastic Ball Link M2 [H0403-S]</p>  <ul style="list-style-type: none"> - 5 x Plastic Ball Link M2. 	<p>19T Motor Pulley [H0501-19-S]</p>  <ul style="list-style-type: none"> - 1 x 19T Motor Pulley Assembly. - 1 x Set Screws M3x6mm.
<p>20T Motor Pulley [H0501-20-S]</p>  <ul style="list-style-type: none"> - 1 x 20T Motor Pulley Assembly. - 1 x Set Screws M3x6mm. 	<p>21T Motor Pulley [H0501-21-S]</p>  <ul style="list-style-type: none"> - 1 x 21T Motor Pulley Assembly. - 1 x Set Screws M3x6mm. 	<p>22T Motor Pulley [H0501-22-S]</p>  <ul style="list-style-type: none"> - 1 x 22T Motor Pulley Assembly. - 1 x Set Screws M3x6mm. 	<p>23T Motor Pulley [H0501-23-S]</p>  <ul style="list-style-type: none"> - 1 x 23T Motor Pulley Assembly. - 1 x Set Screws M3x6mm.
<p>24T Motor Pulley [H0501-24-S]</p>  <ul style="list-style-type: none"> - 1 x 24T Motor Pulley Assembly. - 1 x Set Screws M3x6mm. 	<p>25T Motor Pulley [H0501-25-S]</p>  <ul style="list-style-type: none"> - 1 x 25T Motor Pulley Assembly. - 1 x Set Screws M3x6mm. 	<p>120T Main Pulley [H0502-S]</p>  <ul style="list-style-type: none"> - 1 x 120T Main Pulley . - 1 x Main Pulley Support. - 2 x Shims ϕ 8xϕ 14x0,2mm. - 5 x Head Cap Screws M2x5mm. - 2 x Flanged Bearing ϕ 8xϕ 12x3,5mm. - 1 x One Way Bearing ϕ 8xϕ 12x12mm. 	
<p>Front Tail Pulley [H0503-S]</p>  <ul style="list-style-type: none"> - 1 x Front Tail Pulley Assembly. - 1 x Head Cap Screws Shoulder M2.5x15. - 3 x Head Cap Screws M2x8mm. 	<p>20T Tail Pulley [H0504-S]</p>  <ul style="list-style-type: none"> - 1 x 20T Tail Pulley Assembly. - 1 x Set Screws M3x6mm. 	<p>Washplate Set [H0506-S]</p>  <ul style="list-style-type: none"> - 1 x Swashplate Assembly. - 1 x Rad Bearings ϕ 25x ϕ 32x4. - 6 x Uniballs M2 Male. - 1 x Uniballs M2 Female. - 3 x Button Cap Screws M2x5. - 3 x Swasher ϕ 2.2x ϕ 4x0.3. - 2 x Head Cap Screws M2x8mm. 	<p>Main Shaft [H0507-S]</p>  <ul style="list-style-type: none"> - 1 x Main Shaft. - 1 x Head Cap Screw M3x16mm. - 1 x Metrix Nylon Nut M3.

<p>Spindle Shaft [H0508-S]</p>  <ul style="list-style-type: none"> - 1 x Spindle Shaft. - 2 x Button Cap Screw M4x6mm. 	<p>Tail Shaft [H0509-S]</p>  <ul style="list-style-type: none"> - 1 x Tail Shaft. - 1 x Tail Hub. - 1 x Set Screw M3x6mm. - 2 x Tail Damper. 	<p>Tail Spindle [H0510-S]</p>  <ul style="list-style-type: none"> - 1 x Tail Spindle. - 1 x Socket Cap Screw M2x6mm. - 2 x Washer $\phi 2x\phi 4.5x0.5mm$. 	<p>Tail Blade Grip [H0511-S]</p>  <ul style="list-style-type: none"> - 2 x Tail Blade Grip. - 2 x Thrust Bearing $\phi 3x\phi 6x2.5mm$. - 2 x Bearing $\phi 3x\phi 7x3mm$. - 2 x Bearing $\phi 3x\phi 6x2.5mm$. - 2 x Washer $\phi 3x\phi 4.75x0.5mm$. - 2 x Washer $\phi 4.5x\phi 5.9x0.5mm$. - 2 x Washer $\phi 2x\phi 4.5x0.5mm$. - 2 x Uniball M3.
<p>Tail Pitch Slider [H0512-S]</p>  <ul style="list-style-type: none"> - 1 x Tail Pitch Slider 01. - 1 x Tail Pitch Slider 02. - 1 x Tail Pitch Slider 03. - 2 x Flanged Bearings $\phi 8x\phi 12x3.5mm$. 	<p>Main Blade Grip [H0513-S]</p>  <ul style="list-style-type: none"> - 2 x Blade Grip. - 2 x Thrust Bearing $\phi 5x\phi 10x4$. - 4 x Bearing $\phi 5x\phi 10x4$. - 2 x Washer $\phi 7.5x\phi 10x0.5$. - 2 x Button Head Socket Cap M4x6. - 2 x Washer $\phi 5x\phi 7x0.1$. 	<p>Center Hub [H0514-S]</p>  <ul style="list-style-type: none"> - 1 x Center Hub. - 1 x Socket Head Shoulder M3x16. - 1 x Metrix Hex Nylon Nut M3. 	
<p>Radius Arm [H0516-S]</p>  <ul style="list-style-type: none"> - 2 x Radius Arms. - 2 x Uniball Radius Arms. - 4 x Head Cap Screws M2x10mm. - 8 x Flanged Bearings $\phi 2x\phi 5x2.5$. - 2 x Washer $\phi 2.1x\phi 5x0.5mm$. 	<p>Blade Grip Arm [H0517-S]</p>  <ul style="list-style-type: none"> - 2 x Blade Grip Arm. - 2 x Head Cap Screws M2.5x8. - 2 x Uniball M2. 	<p>Damper Derlin [H0518-S]</p>  <ul style="list-style-type: none"> - 2 x Damper Derlin. - 2 x Oring DI = 6.75, S = 1.78. - 2 x Washer $\phi 7.5x\phi 10x0.5$. - 2 x Button Head Cap M4x6. - 2 x Washer $\phi 5x\phi 7x0.1$. 	<p>Main Plate [H0519-S]</p>  <ul style="list-style-type: none"> - 1 x Main Plate. - 1 x Bearing $\phi 8x\phi 16x5$.
<p>Motor Support [H0520-S]</p>  <ul style="list-style-type: none"> - 1 x Motor Support. - 3 x Head Cap Screws M2.5x8. - 3 x Finishing Washer M2.5. - 1 x Set Screws M4x12. - 1 x Metrix Hex Nylon Nut M4. - 1 x Washer $\phi 4x\phi 11x1mm$. 	<p>Main Shaft Support [H0522-S]</p>  <ul style="list-style-type: none"> - 1 x Main Shaft Support. - 3 x Head Cap Screws M2.5x8. - 1 x Bearing $\phi 8x\phi 16x5$. 	<p>Aluminum Tail Plate [H0523-S]</p>  <ul style="list-style-type: none"> - 1 x Aluminum Tail Plate. - 1 x Flanged Bearing $\phi 5x\phi 13x4$. - 2 x Head Cap Screws M2.5x10. - 2 x Finishing Washer M3. 	<p>Linkage Servo [H0524-S]</p>  <ul style="list-style-type: none"> - 3 x Aluminum Tail Plate.
<p>Plastic Radius Arm [H0525-S]</p>  <ul style="list-style-type: none"> - 2 x Plastic Radius Arm. - 2 x Washer $\phi 2.2x\phi 5x0.3mm$. 	<p>Cros Tail Case [H0526-S]</p>  <ul style="list-style-type: none"> - 1 x Cros Tail Case. - 2 x Head Cap Screw M2.5x6. 	<p>Tail Servo Support [H0530-S]</p>  <ul style="list-style-type: none"> - 1 x Tail Servo Support. - 4 x Button Head Cap Specail M2.5x6. 	<p>Vertical Fin [H1222-S]</p>  <ul style="list-style-type: none"> - 1 x Vertical Fin. - 2 x Finishing Washer M3. - 2 x Head Cap Screws M2.5x6. - 2 x Head Cap Screws M2.5x10.

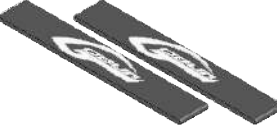

<p>Anti-Rotation Guide (H0533-S)</p>  <p>- 1 x Anti-Rotation Guide. - 2 x Head Cap Screws M2.5x6.</p>	<p>Boom Accessories (H0535-S)</p>  <p>- 1 x M8 Carbon Block. - 2 x Locking Element Tail. - 1 x Double Sided Tape [HA034]. - 1 x Double Sided Tape [HA033]. - 1 x Metrix Hex Nylon Nut M8. - 1 x Metrix Hex Nylon Screw M8. - 4 x Metrix Hex Nylon Nut M2.5.</p>	<p>Uniball M2 Female (H0537-S)</p>  <p>- 2 x Uniball M2 Female.</p>	<p>Uniball M2 Male (H0538-S)</p>  <p>- 5 x Uniball M2 Male.</p>
<p>Battery Block (H0539-S)</p>  <p>- 1 x Battery Block. - 1 x Button Cap Screws M2x5.</p>	<p>Tail Spacer KIT (H0540-S)</p>  <p>- 2 x Washer $\varnothing 3 \times \varnothing 4.75 \times 0.5$. - 2 x Washer $\varnothing 4.5 \times \varnothing 5.9 \times 0.5$. - 2 x Washer $\varnothing 2 \times \varnothing 4.5 \times 0.5$. - 2 x Oring ID=2.9, S=1.78. - 2 x Head Cap Screw M2x6mm.</p>	<p>Canopy Nut (H0542-S)</p>  <p>- 2 x Canopy Nut. - 2 x Set Screws M4x20mm.</p>	<p>Canopy Knob (H0543-S)</p>  <p>- 2 x Canopy Knob.</p>
<p>Plastic Servo Support (H0548-S)</p>  <p>- 1 x Plastic Servo Support. - 1 x Socket Head Cap Screws Shoudered M2.5x18mm.</p>	<p>Linkage Rod M2 (H0561-S)</p>  <p>- 2 x Linkage Rod M2x22mm. - 4 x Plastic Ball Link M2.</p>	<p>FBL Support (H0564-S)</p>  <p>- 1 x FBL Support. - 2 x Head Cap Screw M2.5x8.</p>	<p>Tail Fin Stickers (H1222-01-S)</p>  <p>- 2 x Orange Tail Fin Stickers. - 2 x Yellow Tail Fin Stickers. - 2 x White Tail Fin Stickers.</p>
<p>Tail Servo Spacer (H0572-S)</p>  <p>- 4 x Tail Servo Spacer.</p>	<p>Main Frame (H1180-S)</p>  <p>- 1 x Main Frame.</p>	<p>Battery Tray Guide (H1181-S)</p>  <p>- 1 x Battery Tray Guide SET.</p>	<p>Battery Tray (H1184-S)</p>  <p>- 1 x Battery Tray. - 1 x Battery Straps. - 1 x Double Sided Tape [HA036].</p>
<p>Plastic Landing Gear (H1185-S)</p>  <p>- 1 x Plastic Landing Gear.</p>	<p>380 Canopy (H1186-S)</p>  <p>- 1 x 380 Canopy. - 1 x Canopy Edge Protection. - 2 x Canopy Grommet.</p>	<p>380 Boom (H1187-S)</p>  <p>- 1 x 380 Boom. - 1 x SET Hardware.</p> 	

<p>[HC002-S]</p>  <p>- 8 x Socket Head Cap M2x5mm.</p>	<p>[HC004-S]</p>  <p>- 8 x Socket Head Cap M2x6mm.</p>	<p>[HC005-S]</p>  <p>- 8 x Button Head Cap M2x5mm.</p>	<p>[HC008-S]</p>  <p>- 8 x Socket Head Cap M2x8mm.</p>	<p>[HC010-S]</p>  <p>- 8 x Socket Head Cap M2x10mm.</p>
<p>[HC017-S]</p>  <p>- 8 x Socket Head Cap Screws M2.5x5mm.</p>	<p>[HC018-S]</p>  <p>- 8 x Socket Head Cap Screw M2.5x6mm.</p>	<p>[HC019-S]</p>  <p>- 8 x Button Head Cap Special M2.5x8mm.</p>	<p>[HC020-S]</p>  <p>- 8 x Socket Head Cap M2.5x8mm.</p>	<p>[HC022-S]</p>  <p>- 8 x Socket Head Cap M2.5x10mm.</p>
<p>[HC026-S]</p>  <p>- 8 x Socket Head Cap M2.5x12mm.</p>	<p>[HC031-S]</p>  <p>- 5 x Socket Head Cap Shoulder M2.5x15mm.</p>	<p>[HC032-S]</p>  <p>- 5 x Socket Head Cap M2.5x18mm.</p>	<p>[HC074-S]</p>  <p>- 2 x Socket Head Cap Shoulder M3x16mm. - 2 x Metrix Nylon Nut M3.</p>	<p>[HC096-S]</p>  <p>- 8 x Button Head Cap Screws M4x6mm.</p>
<p>[HC144-S]</p>  <p>- 8 x Cone Point Set Screw M3x6mm.</p>	<p>[HC155-S]</p>  <p>- 5 x Cone Point Set Screw M4x20mm.</p>	<p>[HC156-S]</p>  <p>- 5 x Cone Point Set Screw M4x12mm.</p>	<p>[HC164-S]</p>  <p>- 4 x Nylon Hex Nut M8x14mm.</p>	<p>[HC170-S]</p>  <p>- 10 x Washer Ø2,2xØ5x0,3mm.</p>
<p>[HC184-S]</p>  <p>- 5 x Washer Ø4,3xØ11x1mm.</p>	<p>[HC200-S]</p>  <p>- 8 x Metrix Nylon Nut M2.5.</p>	<p>[HC206-S]</p>  <p>- 8 x Metrix Nylon Nut M3.</p>	<p>[HC212-S]</p>  <p>- 8 x Metrix Nylon Nut M4.</p>	<p>[HC224-S]</p>  <p>- 4 x Metrix Nylon Nut M8.</p>
<p>[HC228-S]</p>  <p>- 4 x Shim Ø8xØ14x0,2mm.</p>	<p>[HC242-S]</p>  <p>- 3 x Thread Rod M2,5x40mm.</p>	<p>[HC400-S]</p>  <p>- 4 x Flanged Bearing Ø2.5xØ6x2.6mm.</p>	<p>[HC411-S]</p>  <p>- 4 x Bearing Ø5xØ10x4mm.</p>	<p>[HC412-S]</p>  <p>- 4 x Flanged Bearing Ø5xØ13x4mm.</p>

<p>[HC416-S]</p>  <p>- 2 x Flanged Bearing Ø7xØ11x2.5mm.</p>	<p>[HC418-S]</p>  <p>- 2 x Flanged Bearing Ø8xØ12x3.5mm.</p>	<p>[HC419-S]</p>  <p>- 2 x Bearing Ø8xØ16x5mm.</p>	<p>[HC435-S]</p>  <p>- 2 x Thrust Bearing Ø5xØ10x4mm.</p>	<p>[HC440-S]</p>  <p>- 1 x One Way Bearing Ø8xØ12x12mm.</p>
<p>[HC448-S]</p>  <p>- 2 x Thrust Bearing Ø3xØ6x2.5mm.</p>	<p>[HC450-S]</p>  <p>- 5 x Washer Ø5xØ7x0.1mm.</p>	<p>[HC453-S]</p>  <p>- 2 x Oring DI=6,75, S=1,78. - 2 x Oring DI=2.9, S=1,78.</p>	<p>[HC454-S]</p>  <p>- 1 x Belt 304-2GT-09.</p>	<p>[HC455-S]</p>  <p>- 1 x Belt 1140-HTD-2.</p>
<p>[HC456-S]</p>  <p>- 4 x Flanged Bearing Ø2xØ5x2.5mm.</p>	<p>[HC457-S]</p>  <p>- 4 x Bearing Ø3Ø6x2.5mm.</p>	<p>[HC458-S]</p>  <p>- 4 x Bearing Ø3Ø7x3mm.</p>	<p>[HC459-S]</p>  <p>- 1 x Rad Bearing Ø25Ø32x4mm.</p>	<p>[HC460-S]</p>  <p>- 1 x Spherical Bearing Ø12xØ22x7mm.</p>
<p>[HC461-S]</p>  <p>- 1 x Tail Push Rod Ø4xØ2,5x420mm. - 2 x Plastic Ball Link. - 2 x Thread Rod M2,5.</p>	<p>[HC462-S]</p>  <p>- 4 x Shim Ø8xØ12x0.1mm.</p>	<p>[HA016-S]</p>  <p>- 2 x Wrench Tool M8,M6.</p>	<p>[HA021-S]</p>  <p>- 4 x Canopy Grommet.</p>	<p>[HA032-S]</p>  <p>- 1 x Foam Blade Holder.</p>
<p>[HA035-S]</p>  <p>- 2 x Double-sided Tape 1 mm Battery .</p>	<p>[HA036-S]</p>  <p>- 2 x Battery Straps.</p>	<p>[HA052-S]</p>  <p>- 1 x Tail Servo Horn. - 3 x Cyclic Servo Horn.</p>	<p>[HA112-S]</p>  <p>- 1 x Canopy Edge Protection (1m).</p>	<p>[H0554-S]</p>  <p>- 2 x Tail Blade 70mm.</p>
<p>[BL380-3DS]</p>  <p>- 2 x Main Blade 380.</p>				

GOBLIN



- Carefully check your model before each flight to ensure it is airworthy.
- Consider flying only in areas dedicated to the use of model helicopters.
- Check and inspect the flying area to ensure it is clear of people obstacles.
- Rotor blades can rotate at very high speeds! Be aware of the danger they pose.
- Always keep the model at a safe distance from other pilots and spectators.
- Avoid maneuvers with trajectories towards a crowd.
- Always maintain a safe distance from the model.

GOBLIN 380 BUDDY

Release 1.0 - November 2019

WORLD DISTRIBUTION

www.goblin-helicopter.com

For sales inquiries, please email:

sales@goblin-helicopter.com

For info inquiries, please email:

support@goblin-helicopter.com

Attention: If you are a customer and have questions or need of assistance, please contact in a first time the Goblin retailer where you made the purchase.

EUROPEAN DISTRIBUTION

www.sabitaly.it

For sales inquiries, please email:

sales@sabitaly.it

For info inquiries, please email:

info@sabitaly.it

Attention: If you are a customer and have questions or need of assistance, please contact in a first time the Goblin retailer where you made the purchase.



WWW.GOBLIN-HELICOPTER.COM

SAB HELI DIVISION