



KRAKEN

MANUAL



SAB HELI DIVISION



Please read this user manual carefully, it contains instructions for the correct assembly of the model.
Please refer to the web site www.goblin-helicopter.com for updates and other important information.

**VERY IMPORTANT**

You will find your serial number on the RED plate of the transmission module and on the product card included with your kit.
Please take a moment to register your kit online via our web site at:

<http://www.goblin-helicopter.com>

It is extremely important that you take a moment to register your helicopter with us. This is the only way to ensure that you are properly informed about changes to your kit, such as upgrades, retrofits and other important developments. SAB Heli Division cannot be held responsible for any issues with your model and will not provide support unless you register your model.

The Serial number is also engraved in the Aluminum part.

Thank you for your purchase, we hope you enjoy your new Goblin helicopter!

SAB Heli Division

INDEX

- 1 – Introduction
- 2 – Important Notes**
- 3 – Note for Assembly
- 4 – Carbon Rod Assembly
- 5 – Transmission Group Assembly
- 6 – Swashplate Servos Assembly
- 7 – Frame Group Assembly

- 8 – Head Assembly
- 9 – Assembling of the modules
- 10 – Tail Group Assembly
- 11 – Tail Boom Assembly
- 12 – Low Side Frame Installation
- 13 – Landing Gear Installation
- 14 – Installation of The Motor

- 15 – Installation ESC/FBL/RX
- 16 – Installation Batteries
- 17 – Installation Canopy
- 18 – In flight**
- 19 – Maintenance
- 20 – Transmission Module
- 21 – Check list**
- 22 – Spare Parts

GOBLIN KRAKEN TECHNICAL SPECIFICATIONS



- **AIRFRAME weight:** 2680 (with blades, no battery, no electronics).
- **Main rotor diameter:** 1558 mm (with 690 mm blades).
- **Main blade length:** 650 to 730mm.
- **Tail rotor diameter:** 284 mm (with 105 mm tail blades).
- **Tail blade length:** 105 to 115 mm.

- **Cyclic Servos:** Standard size 40mm.
- **Tail Servo:** Standard size 40mm.
- **Main Rotor Ratio :** 12.1 to 8.8 :1 (21T included: 10.4:1).
- **Tail Rotor Ratio :** 5.0-4.8:1 (27T included: 4.8:1).

KIT Includes:

- 21T motor pulley (other pulley sizes available).
- 2 battery trays with straps.
- 690 mm main blades.
- 105 mm tail blades.

IMPORTANT NOTES

- *This radio controlled helicopter is not a toy.
- *This radio controlled helicopter can be very dangerous.
- *This radio controlled helicopter is a technically complex device which has to be built and handled very carefully.
- *This radio controlled helicopter must be built following these instructions. This manual provides the necessary information to correctly assemble the model.
It is necessary to carefully follow all the instructions.
- *Inexperienced pilots must be monitored by expert pilots.
- *All operators must wear safety glasses and take appropriate safety precautions.
- *A radio controlled helicopter must only be used in open spaces without obstacles, and far enough from people to minimize the possibility of accidents or of injury to property or persons.
- *A radio controlled helicopter can behave in an unexpected manner, causing loss of control of the model, making it very dangerous.
- *Lack of care with assembly or maintenance can result in an unreliable and dangerous model.

***Neither SAB Heli Division nor its agents have any control over the assembly, maintenance and use of this product. Therefore, no responsibility can be traced back to the manufacturer. You hereby agree to release SAB Heli Division from any responsibility or liability arising from the use of this product.**

SAFETY GUIDELINES

- *Fly only in areas dedicated to the use of model helicopters.
- *Follow all control procedures for the radio frequency system.
- *It is necessary that you know your radio system well. Check all functions of the transmitter before every flight.
- *The blades of the model rotate at a very high speed; be aware of the danger they pose and the damage they may cause.
- *Never fly in the vicinity of other people.

DAMAGE LIMITS

SAB HELI DIVISION SHALL NOT BE LIABLE FOR SPECIAL, INDIRECT OR CONSEQUENTIAL DAMAGES, LOSS OF PROFITS OR PRODUCTION OR COMMERCIAL LOSS IN ANY WAY CONNECTED WITH THE PRODUCT, WHETHER SUCH CLAIM IS BASED IN CONTRACT, WARRANTY, NEGLIGENCE, OR STRICT LIABILITY. Further, in no event shall the liability of SAB Heli Division exceed the individual price of the Product on which liability is asserted. As SAB Heli Division has no control over use, setup, final assembly, modification or misuse, no liability shall be assumed nor accepted for any resulting damage or injury. By the act of use, setup or assembly the user accepts all resulting liability. If you as the Purchaser or user are not prepared to accept the liability associated with the use of this Product, you are advised to return this Product immediately in new and unused condition to the place of purchase.

LIMITED WARRANTY

SAB Heli Division reserves the right to change or modify this warranty without notice and disclaims all other warranties, express or implied.

- (a)** This warranty is limited to the original Purchaser (“Purchaser”) and is not transferable. REPLACEMENT AS PROVIDED UNDER THIS WARRANTY IS THE EXCLUSIVE REMEDY OF THE PURCHASER. This warranty covers only those Products purchased from an authorized SAB Heli Division dealer. Third party transactions are not covered by this warranty. Proof of purchase is required for warranty claims.
- (b)** Limitations- SAB HELI DIVISION MAKES NO WARRANTY OR REPRESENTATION, EXPRESS OR IMPLIED, ABOUT NONINFRINGEMENT, MERCHANTABILITY OR FITNESS FOR A PARTICULAR PURPOSE OF THE PRODUCT. THE PURCHASER ACKNOWLEDGES THAT THEY ALONE HAVE DETERMINED THAT THE PRODUCT WILL SUITABLY MEET THE REQUIREMENTS OF THE PURCHASER’S INTENDED USE.
- (c)** Purchaser Remedy- SAB Heli Division’s sole obligation hereunder shall be that SAB Heli Division will, at its option, replace any Product determined by SAB Heli Division to be defective. In the event of a defect, this is the Purchaser’s exclusive remedy. Replacement decisions are at the sole discretion of SAB Heli Division. This warranty does not cover cosmetic damage or damage due to acts of God, accident, misuse, abuse, negligence, commercial use, or modification of or to any part of the Product. This warranty does not cover damage due to improper installation, operation, maintenance or attempted repair by anyone.

NOTE FOR ASSEMBLY



ADDITIONAL COMPONENTS REQUIRED





- *Electronic Motor
- *Speed controller
- *Batteries: 12S – 4200/5500mAh
- *1 flybarless 3 axis control unit
- *Radio power system.
- *3 cyclic servos
- *1 tail rotor servo
- *6 channel radio control system on 2.4 GHz

TOOLS, LUBRICANTS, ADHESIVES

- *Generic pliers.
- *Hexagonal driver, size 1.5, 2, 2.5, 3mm.
- *4/5mm T-Wrench.
- *5.5mm Socket wrench (for M3 nuts).
- *8mm Hex fork wrench (for M5 nuts).
- *Medium threadlocker (SAB p/n HA116-S).
- *Strong retaining compound (SAB p/n HA115-S).
- *Spray lubricant (eg. Try-Flow Oil).
- *Synthetic grease (eg. Microlube 261).
- *Cyanoacrylate adhesive.
- *Pitch Gauge (for set-up).
- *Soldering equipment (for motor wiring).

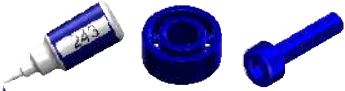
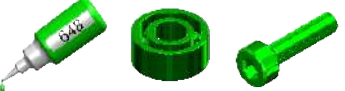
NOTES FOR ASSEMBLY

Please refer to this manual for assembly instructions for this model. Follow the order of assembly indicated. The instructions are divided into chapters, which are structured in a way that each step is based on the work done in the previous step. Changing the order of assembly may result in additional or unnecessary steps. Use thread lockers and retaining compounds as indicated. In general, each bolt or screw that engages with a metal part requires thread lock. It is necessary to pay attention to the symbols listed below:

 <p>Important</p>	 <p>Blue screw and blue bearing in the illustration means you need to use: Thread Locker Medium Strength (SAB HA116-S)</p>	 <p>Green screw and Green bearing in the illustration means you need to use: Use retaining compound (SAB HA115-S)</p>
 <p>Indicates that for this assembly phase you need materials that are: Foam xxx, BAG xxx.</p>	 <p>Use CA Glue</p>	 <p>Use Proper Lubricant</p>

INSIDE THE MAIN BOX THERE ARE:

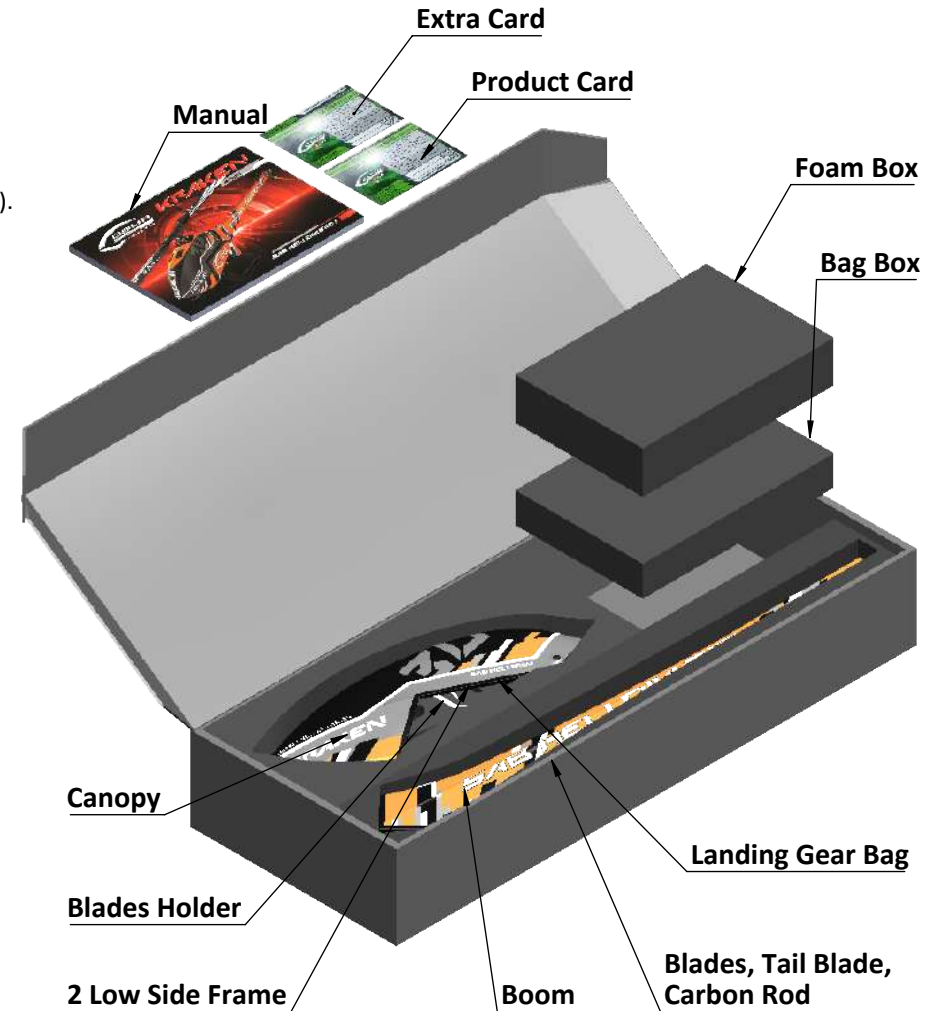

The assembly process is described in the following chapters. Each chapter provides you with the box, bag and/or foam numbers you will need for that chapter. The information is printed in a black box in the upper corner of the page.

BAG 1

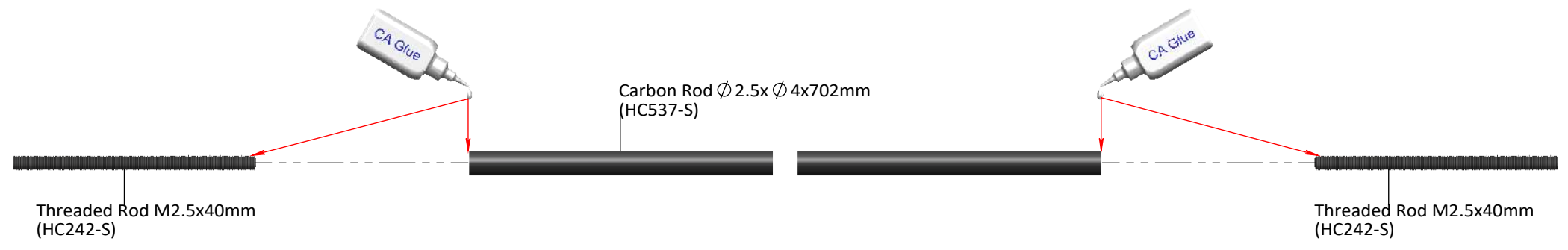

NOTE:

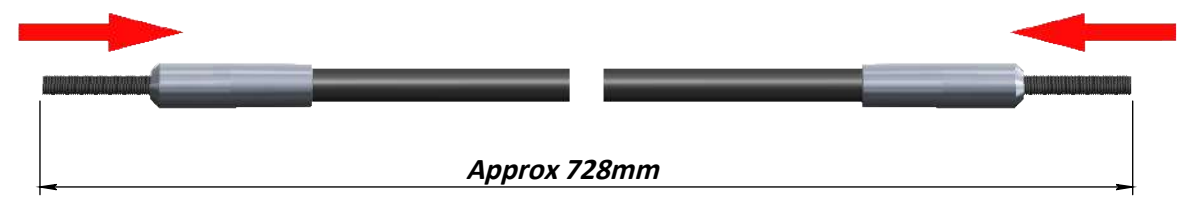

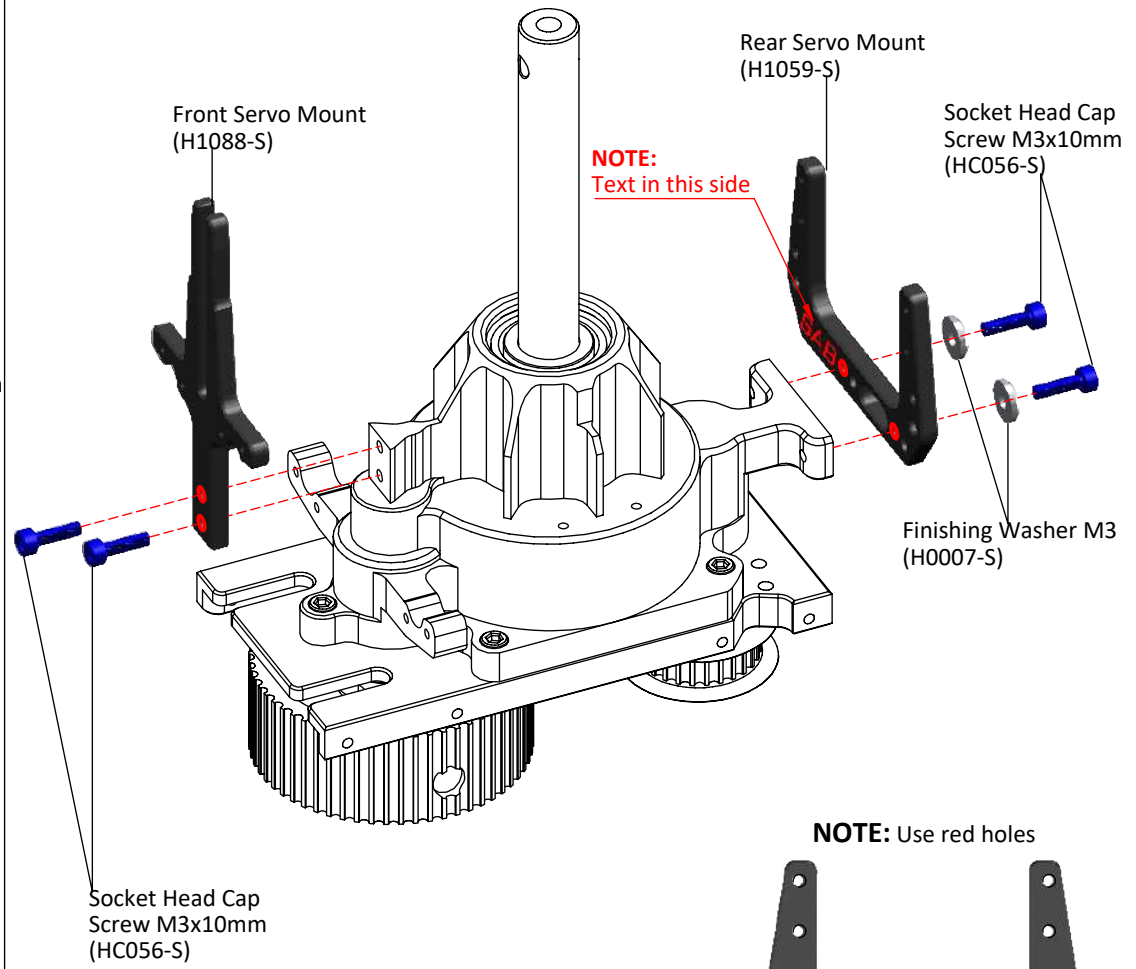
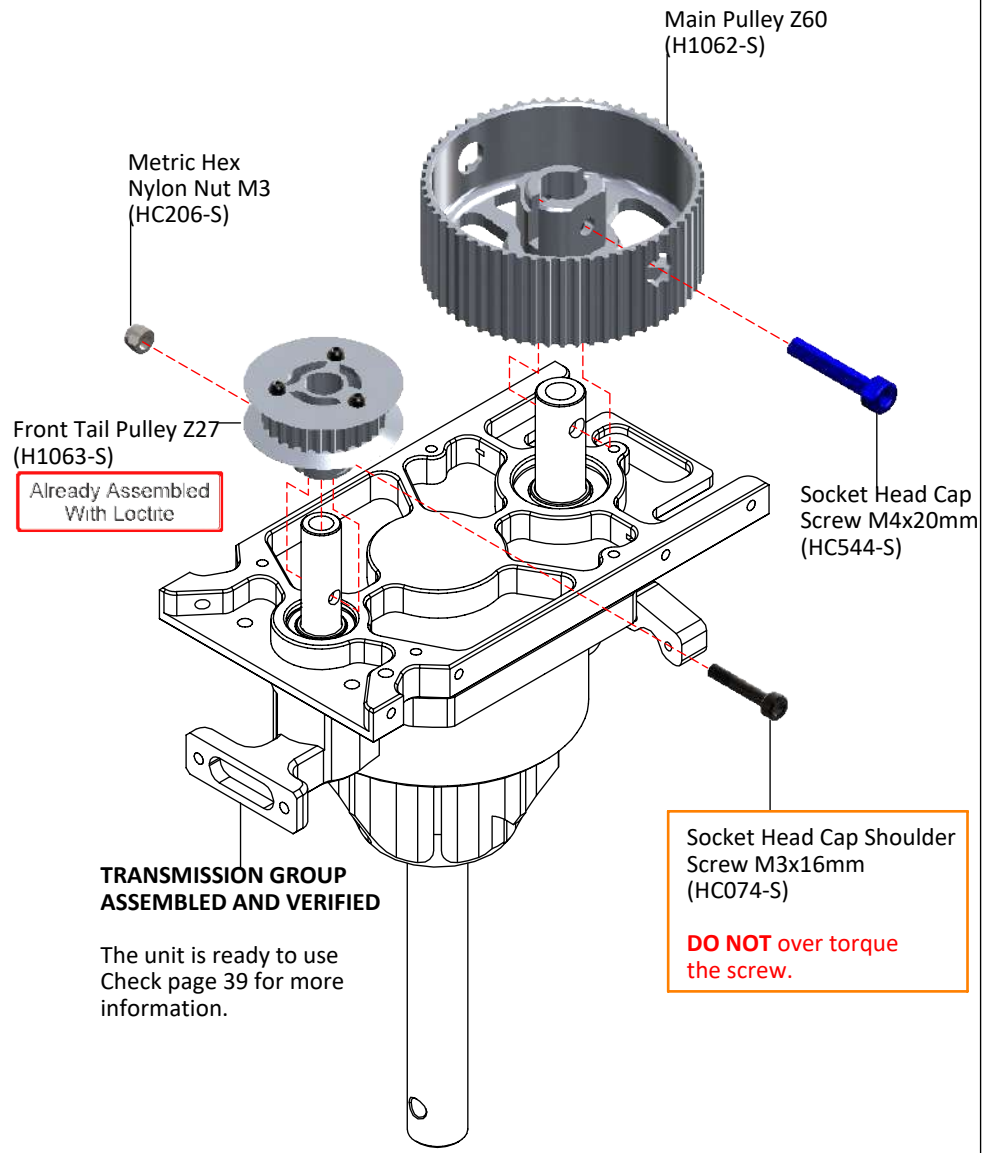

BAG 3

SERVO ASSEMBLY

The linkage ball must be positioned 18 mm out on the servo arm. The recommended servo arm to use is: SAB p/n [HA050/HA051].

Ensure the alignment of the servo arms (and sub trim set) before installation of the servos in the model.

Proceed with installation following the instructions below. You can use the G10 servo tool to align the front servo arms with the theoretical horizontal line. **(Figure 3)**

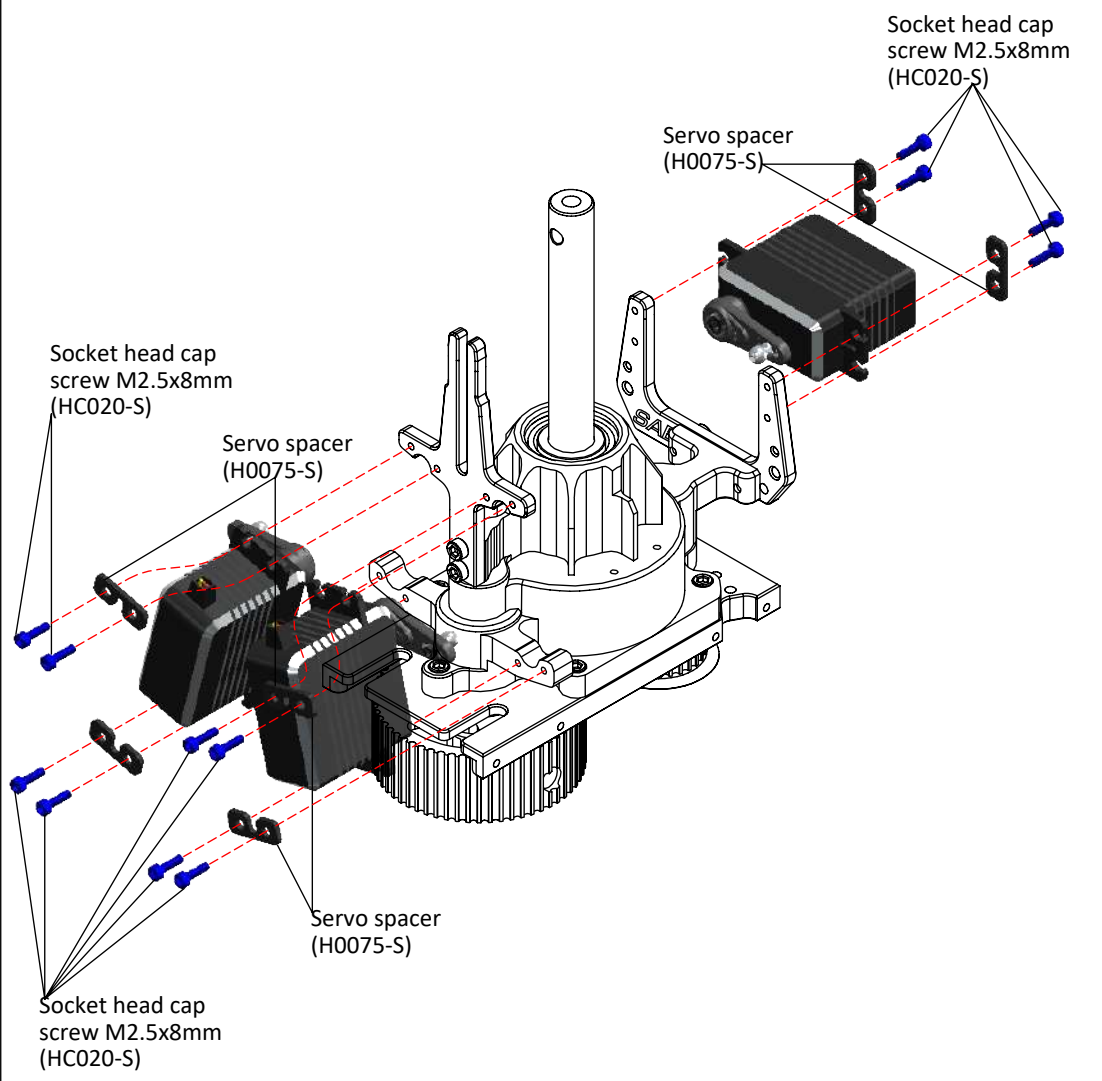
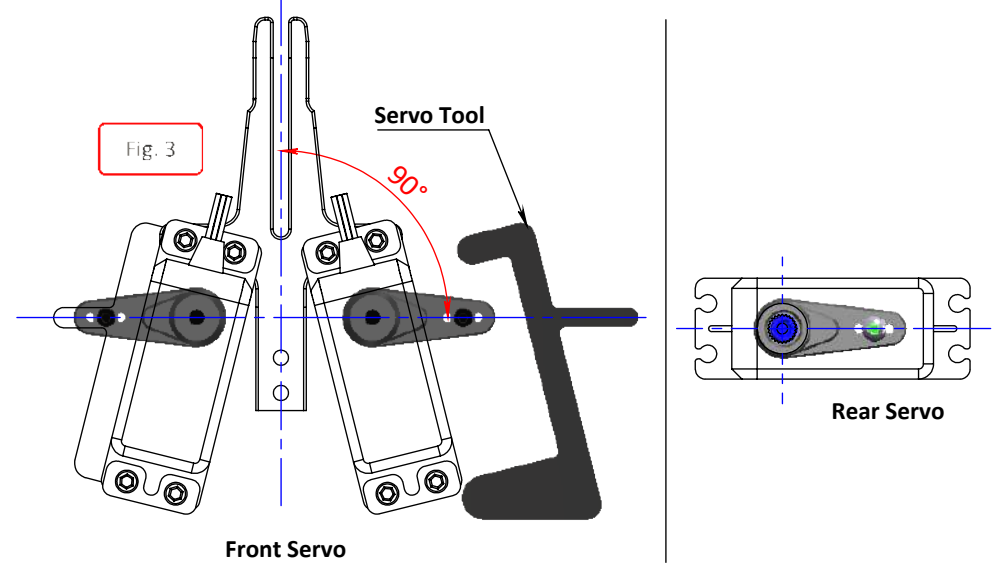
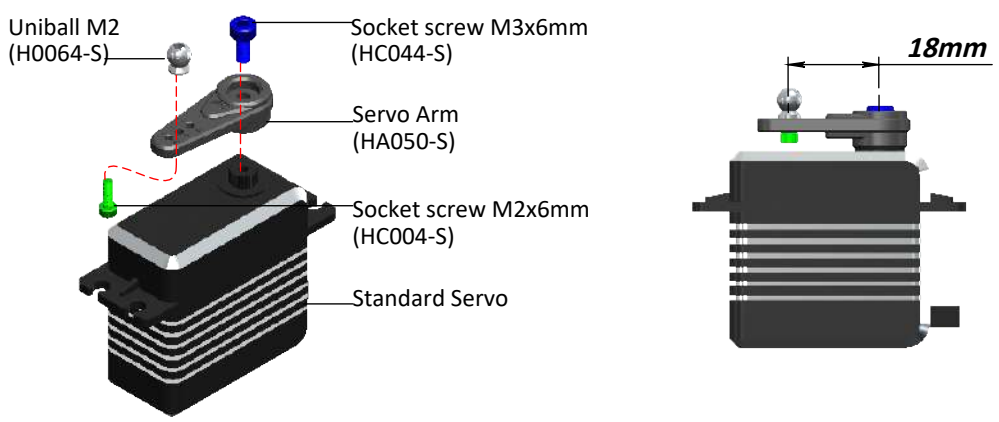

RIGHT FRAME ASSEMBLY

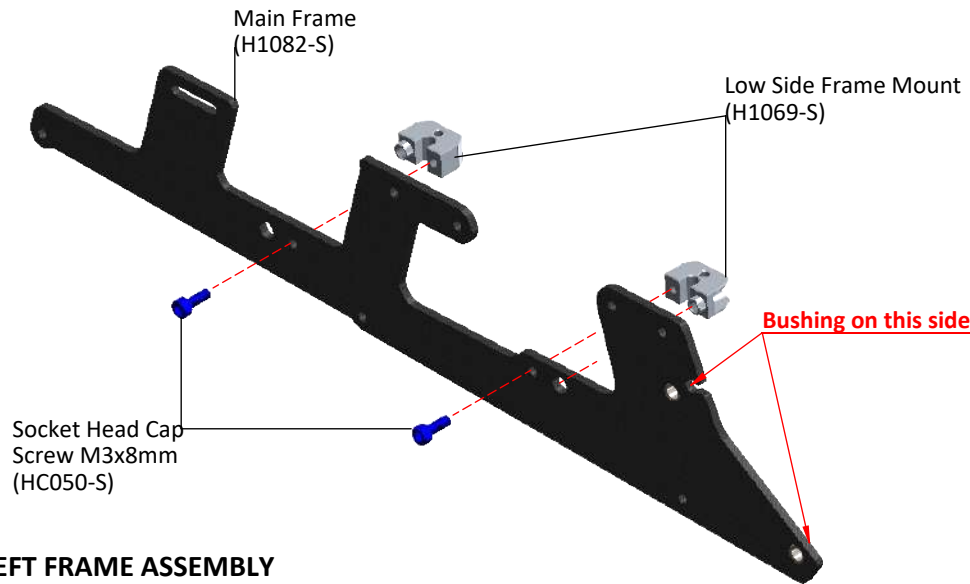

LEFT FRAME ASSEMBLY

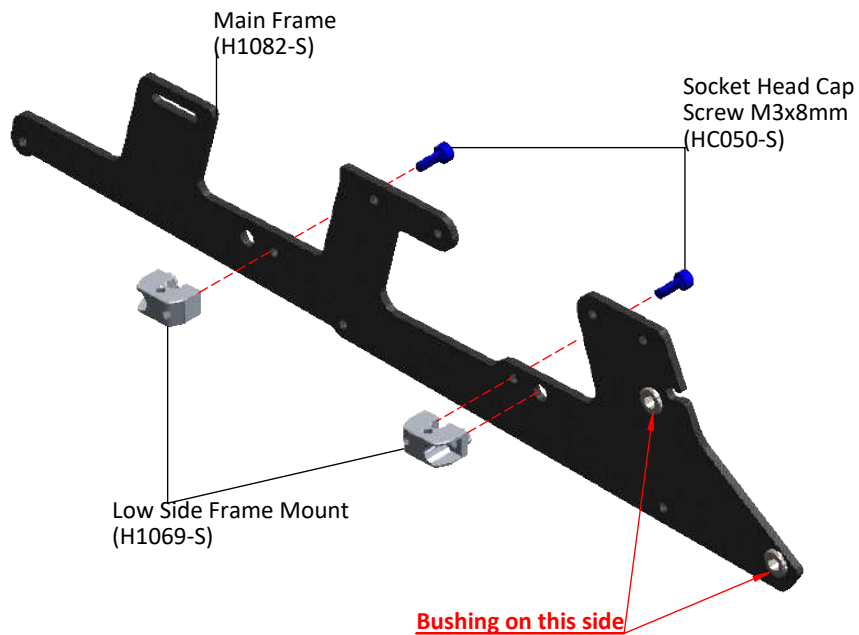

BATTERY GUIDE ASSEMBLY

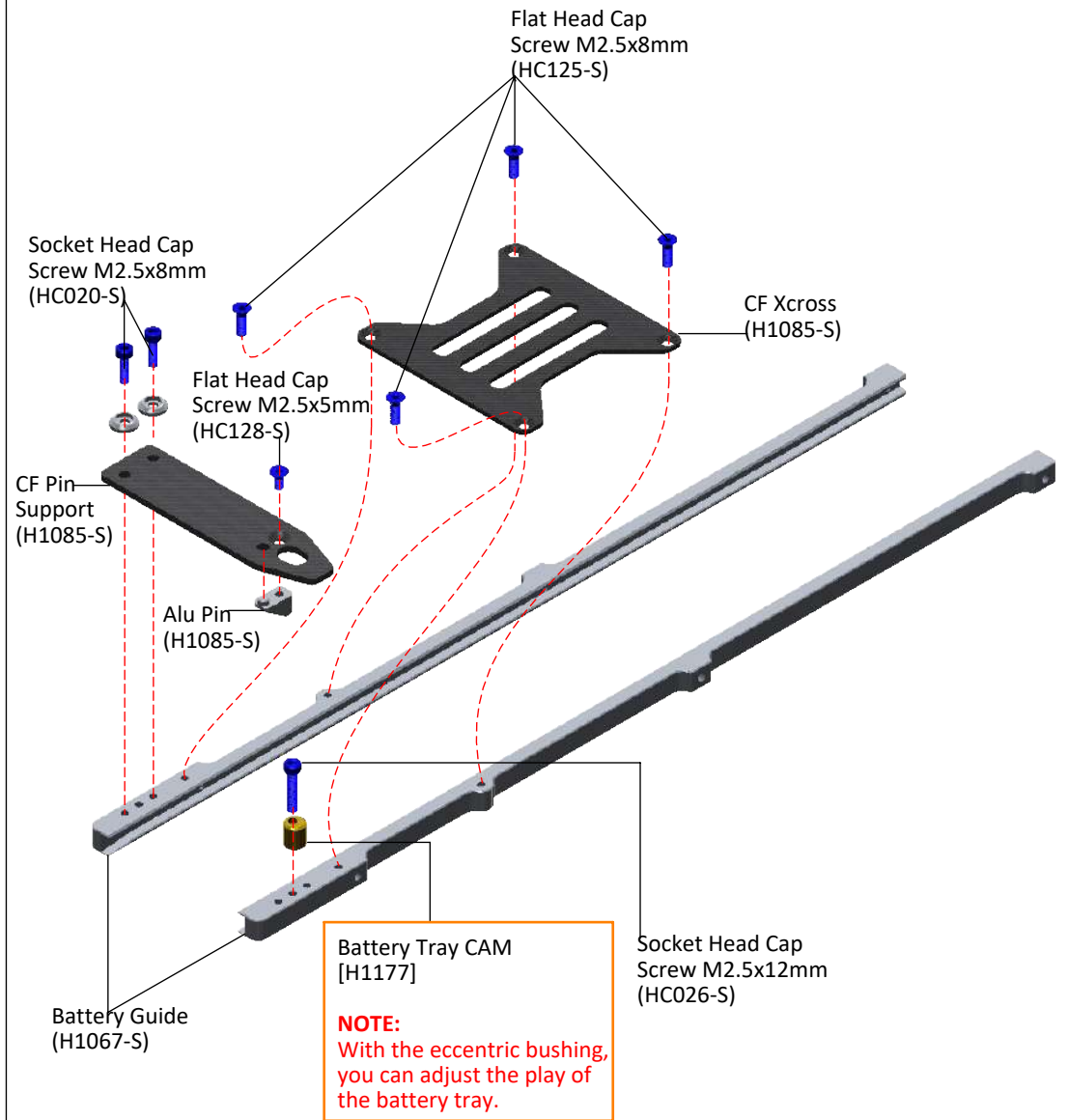

BAG4

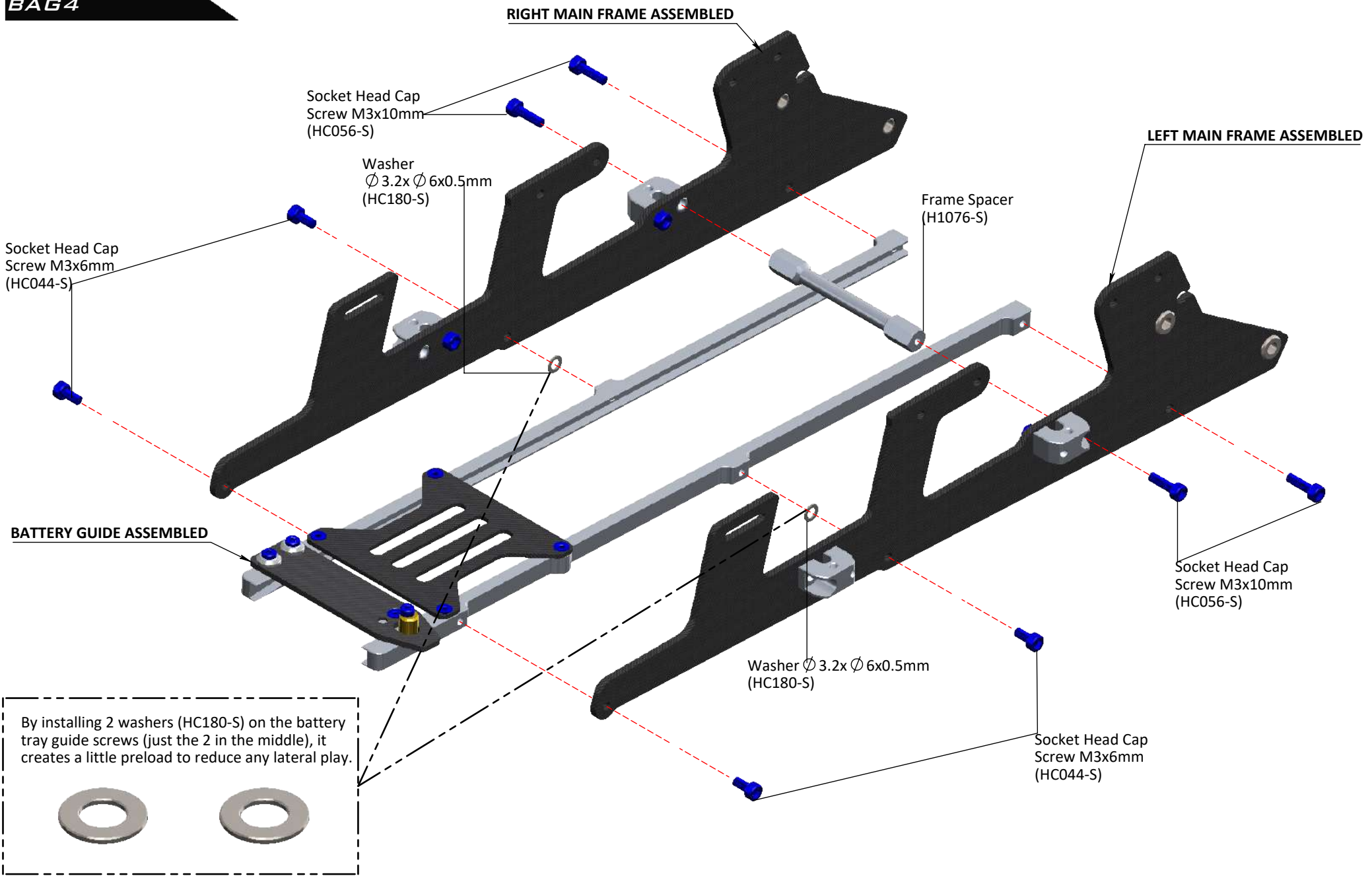

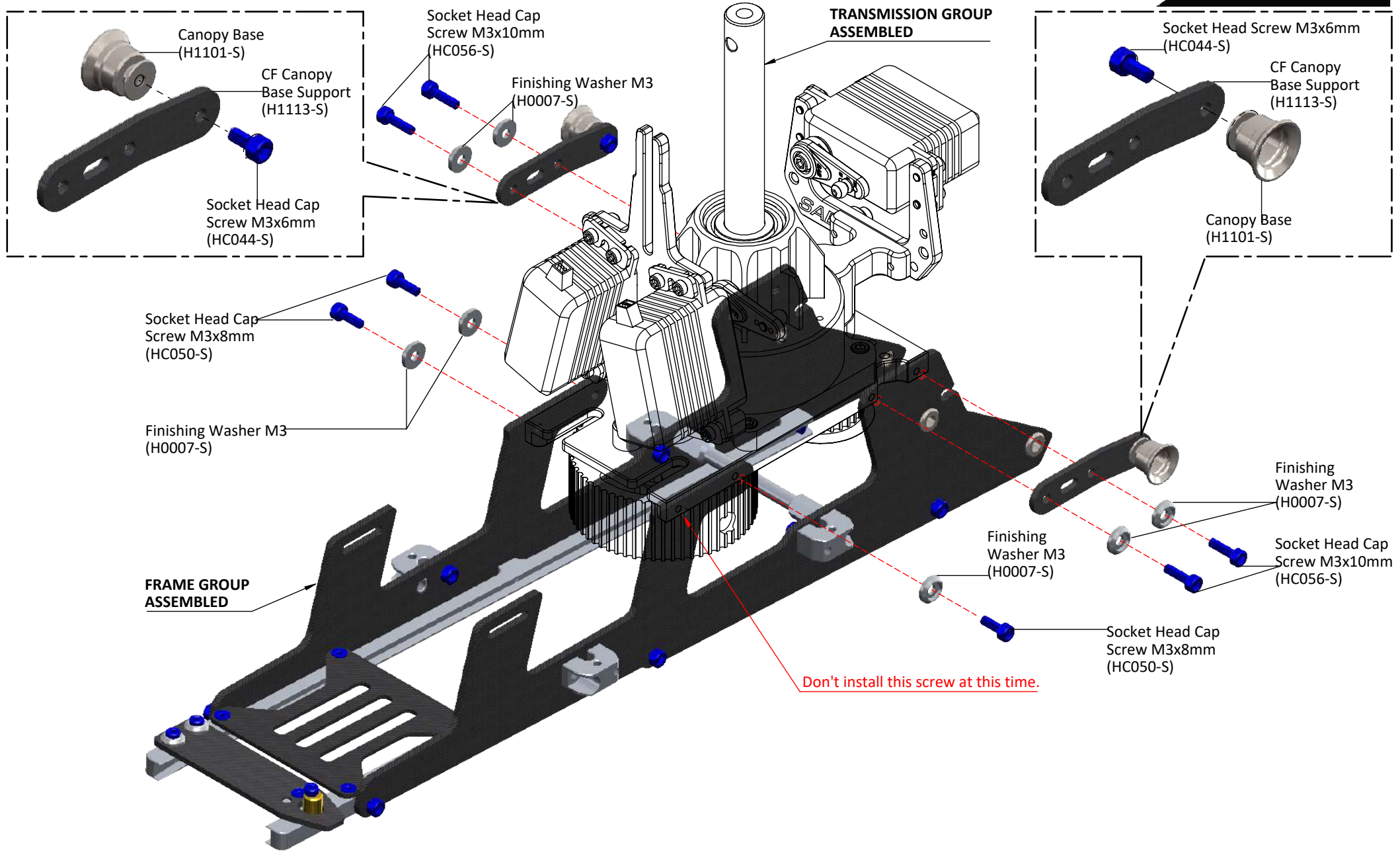

FOAM 2, BAG 6

UNIBALL RADIUS ARM ASSEMBLY ...X2

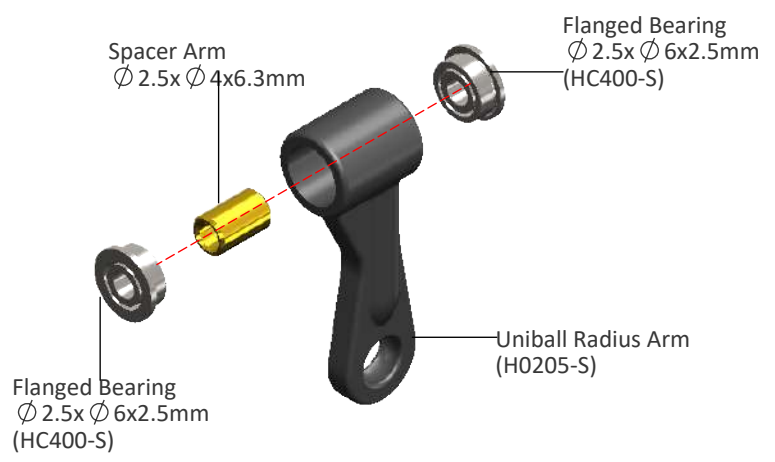

CENTER HUB ASSEMBLY

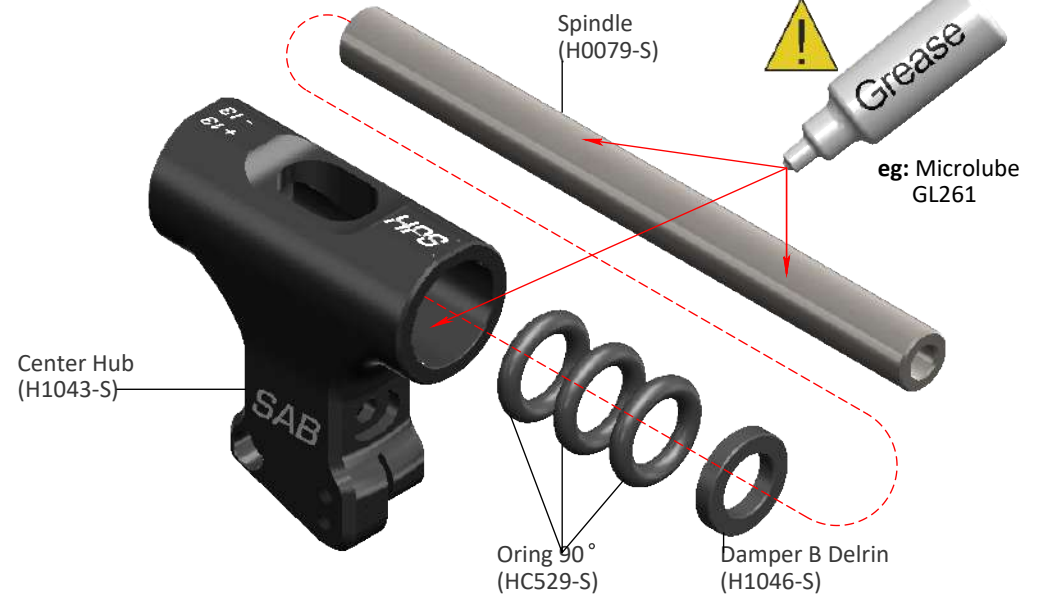

RADIUS ARM ASSEMBLY ...X2

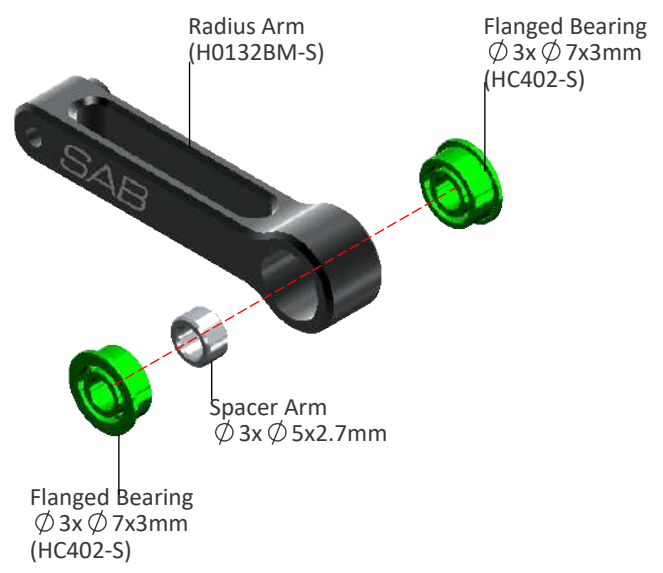

LINKAGE ROD A ASSEMBLY ...X2

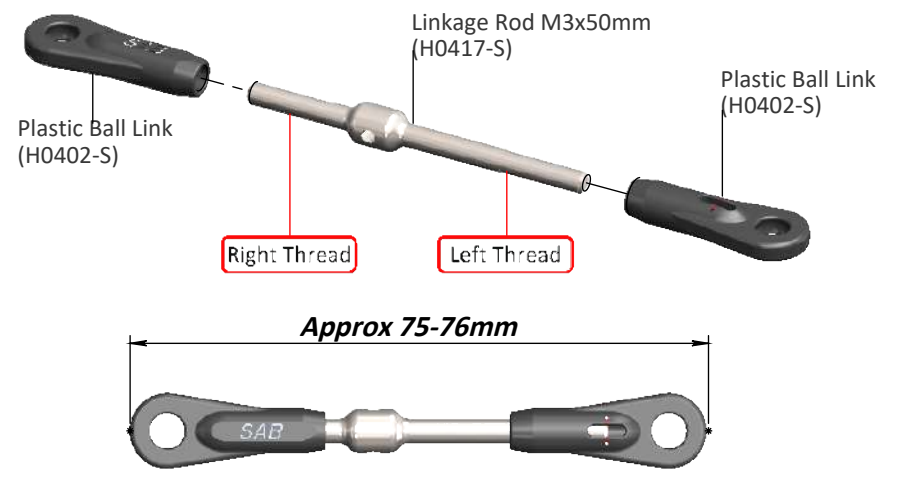

NOTE:

Washer $\varnothing 10x \varnothing 16x0.2mm$
[HC232-S]



The HPS head should be assembled with one, 1mm shim (HC230) on each side. The blade grips must move freely, but they should not move just under their own weight. After approximately 10/20 flights, please check preload, you can add one or two 0.2mm shim (HC232) if preload has changed.

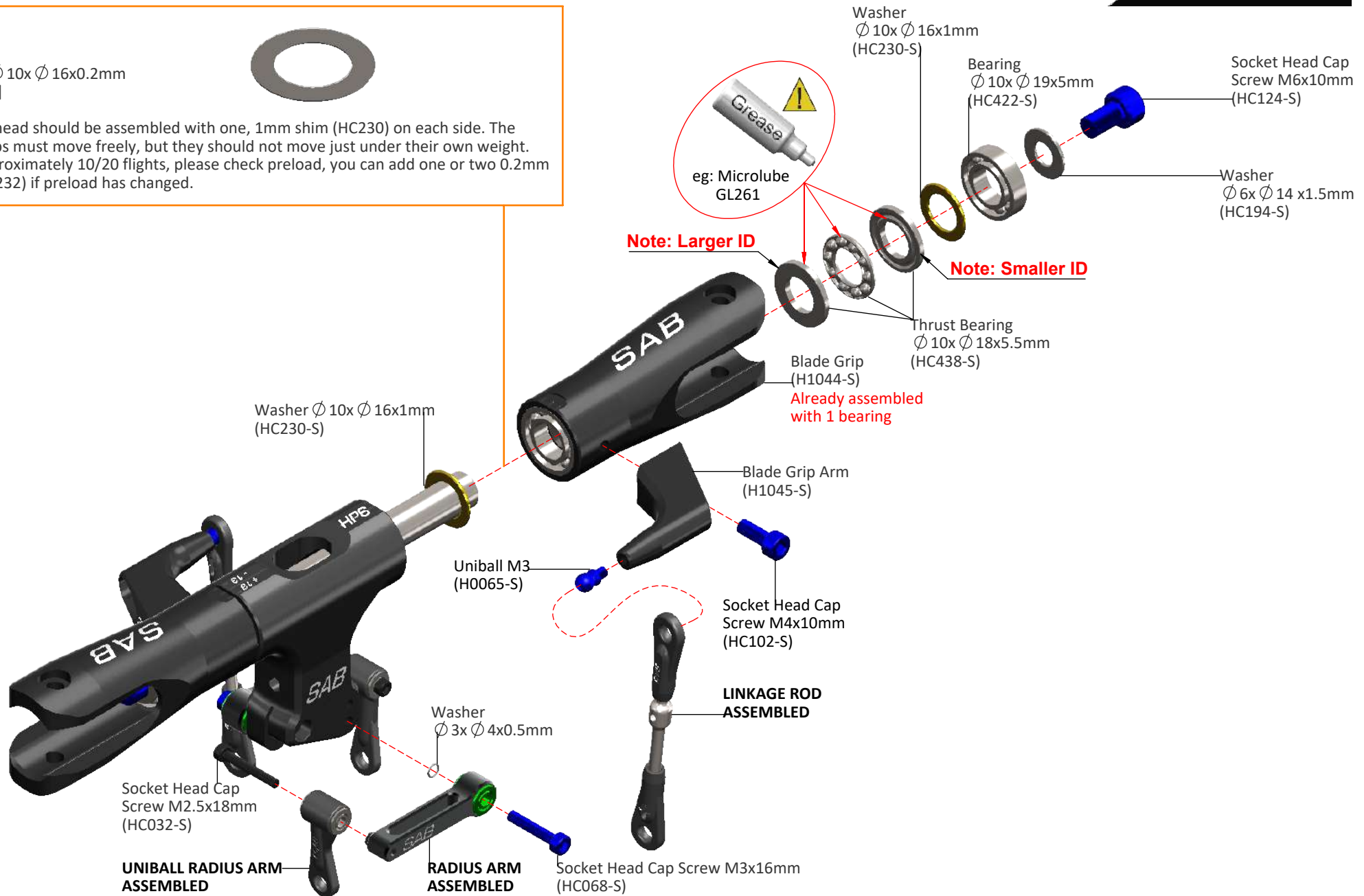

FOAM 2, BAGB

SWASHPLATE ASSEMBLY

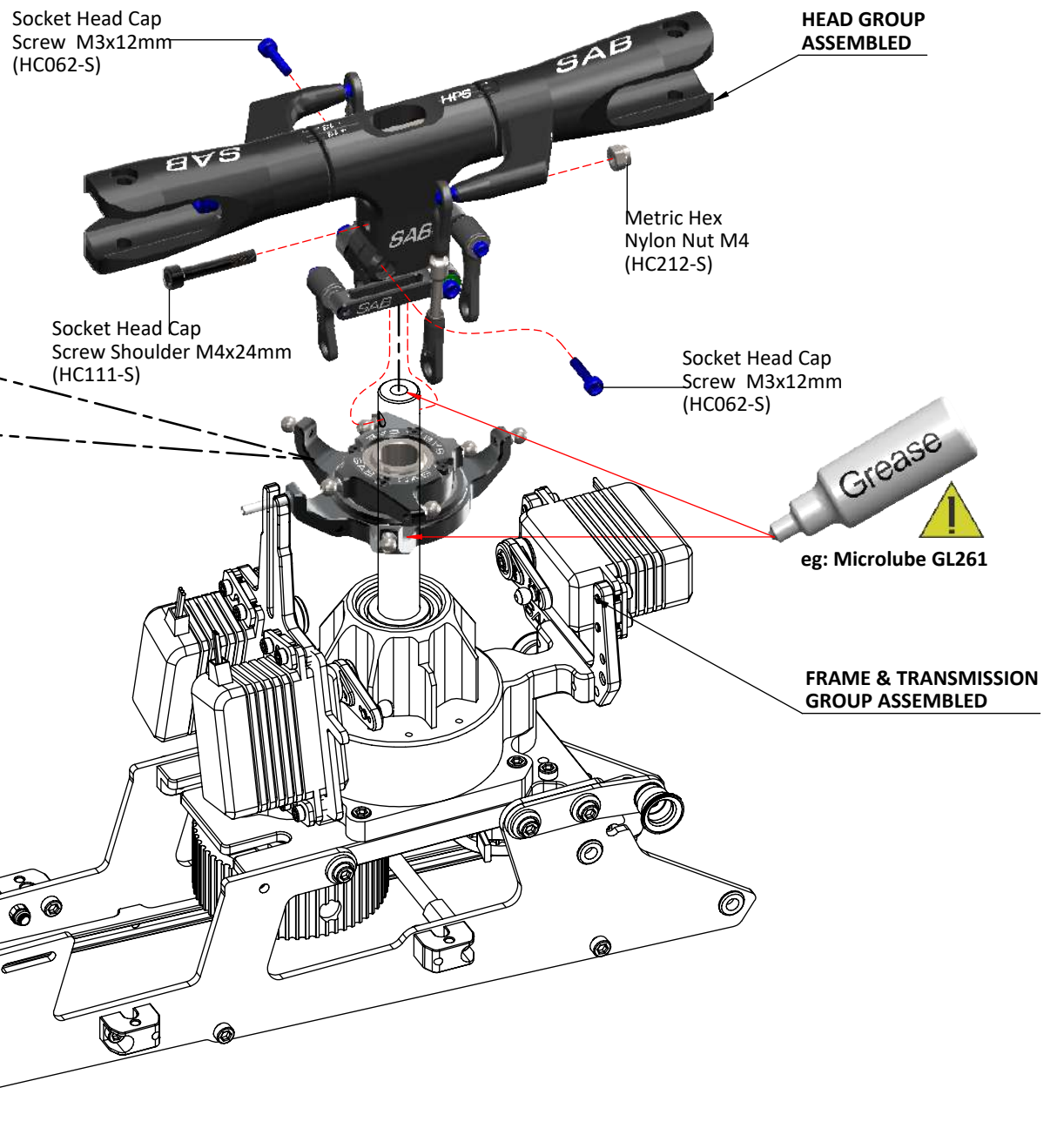
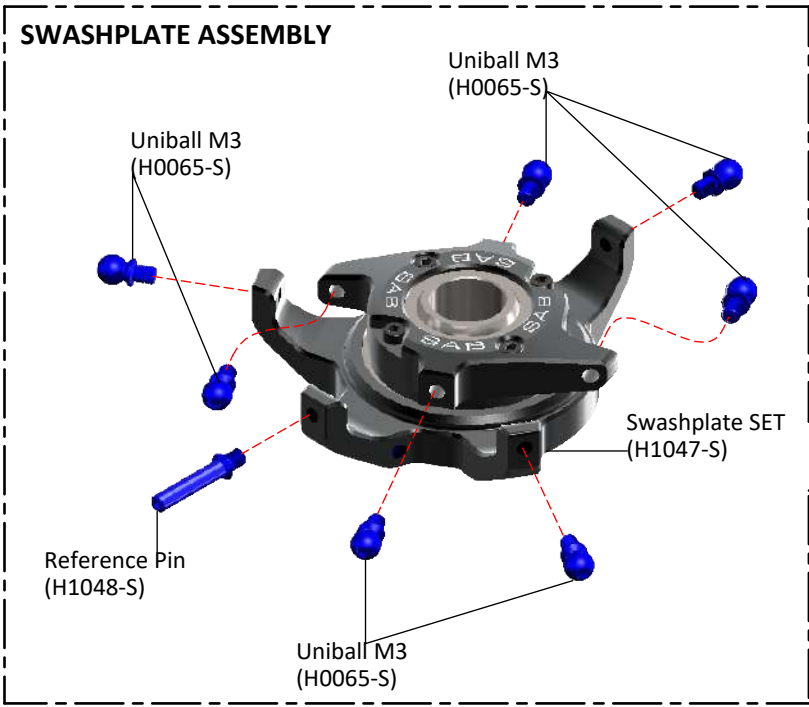

LINKAGE ROD B ASSEMBLY ... X3

Approx 46mm

Plastic ball link (H0066-S) Plastic ball link (H0066-S)

Set Screw M2.5x18mm (HC140-S)

Initial length for the rods from the servos to the swash plate.

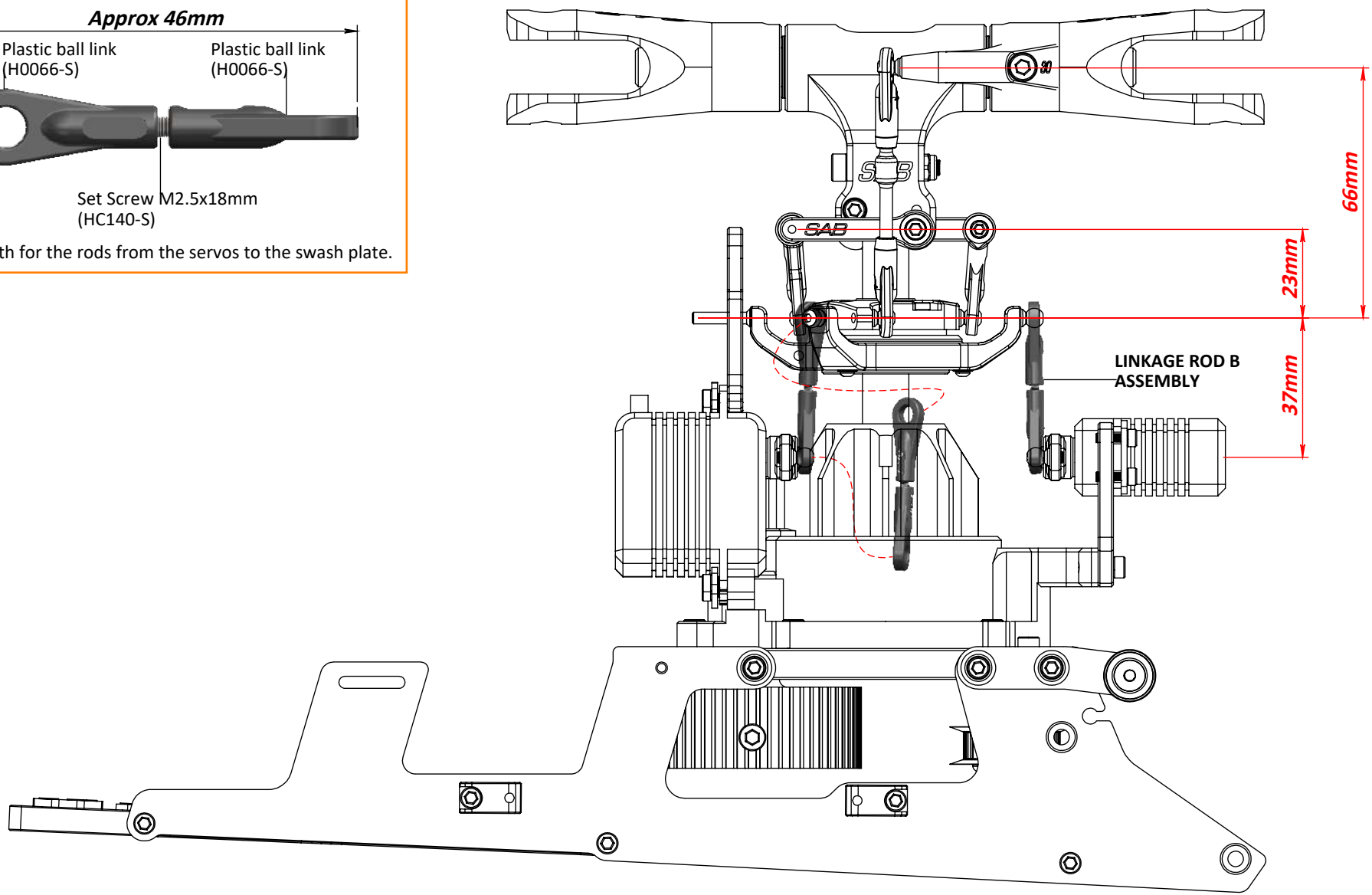

FOAM 2, BAG 9

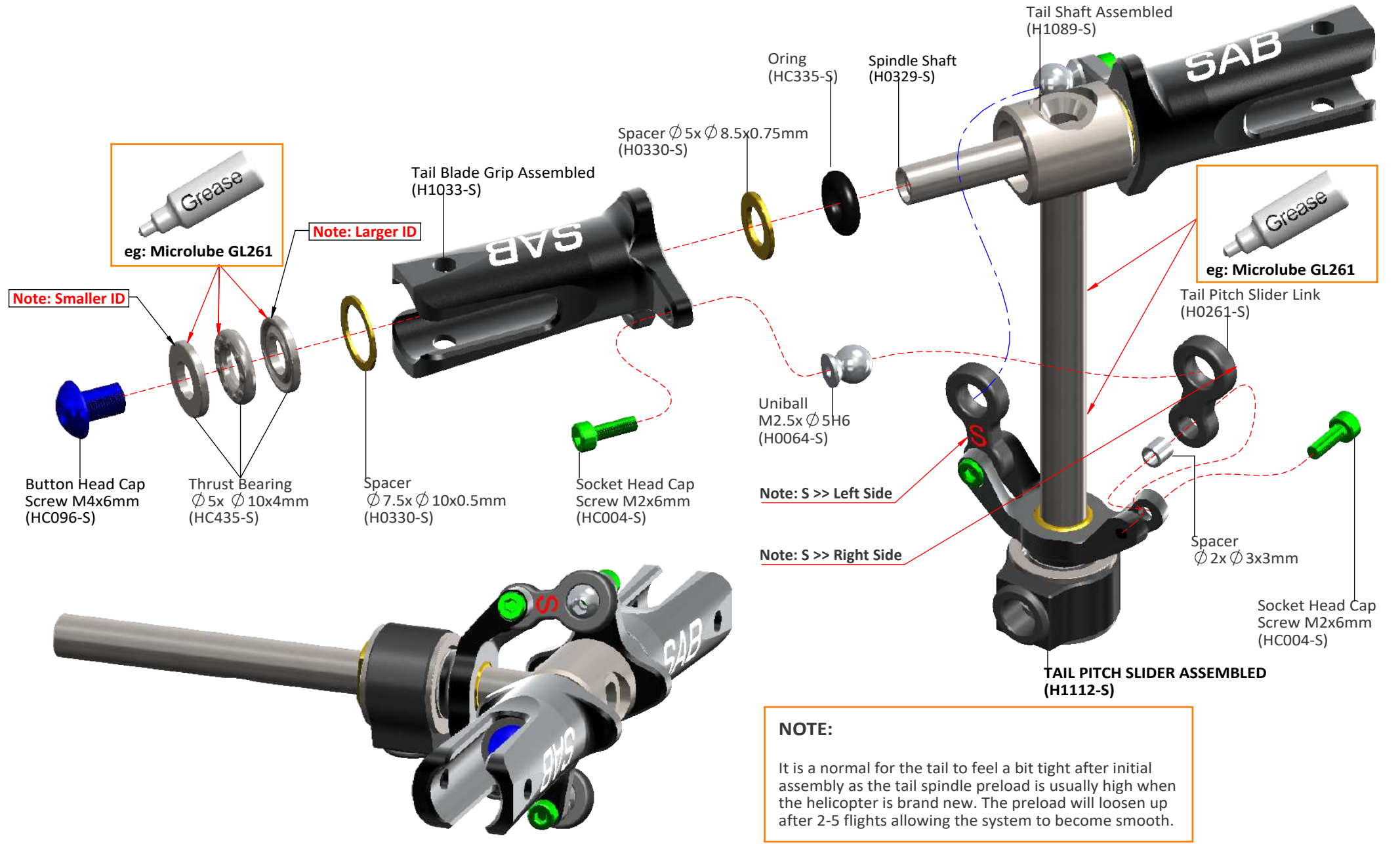

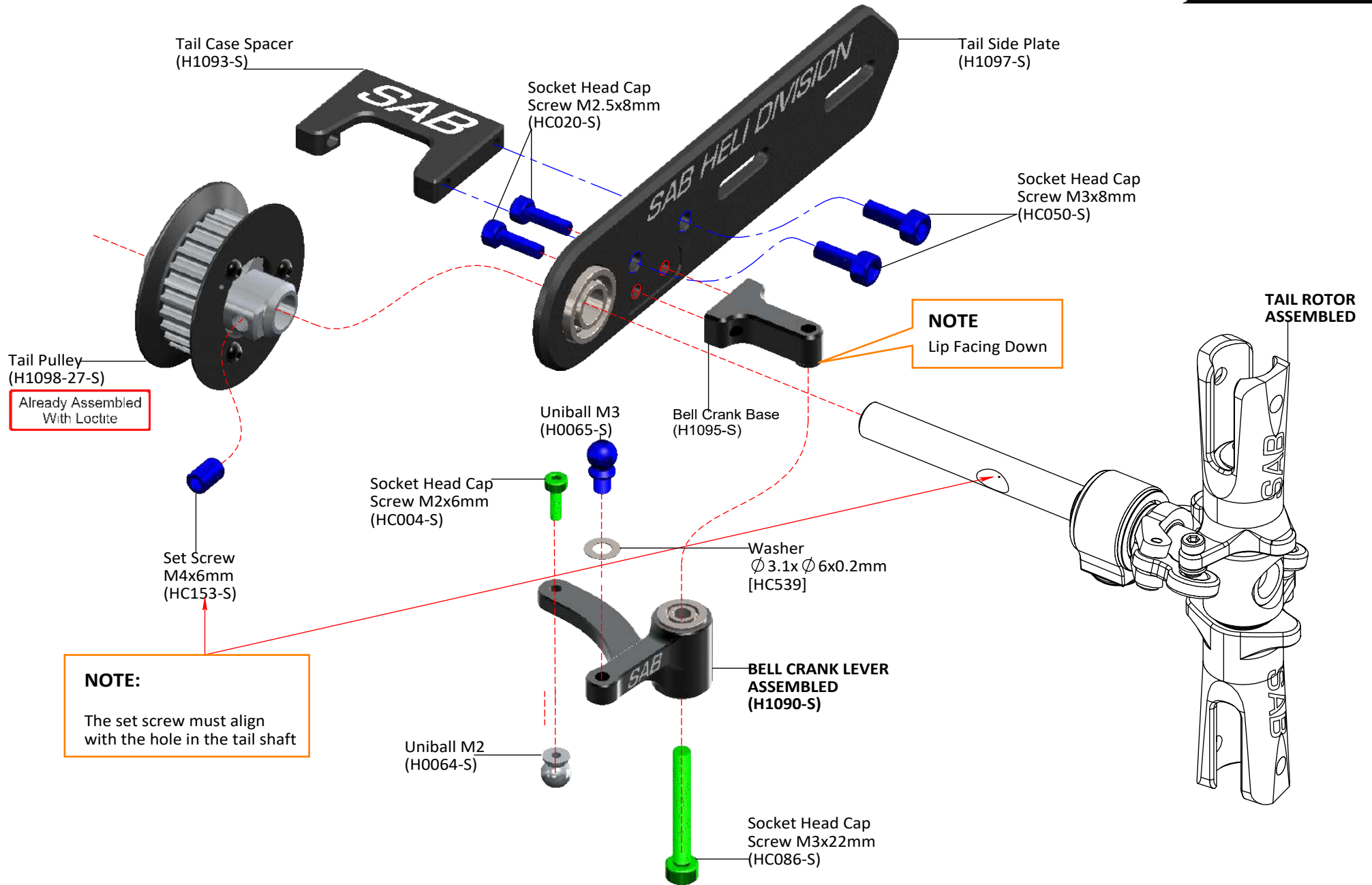

BAG 1 1

Flat Head Cap
Screw M3x10mm
(HC135-S)

Socket Head Cap
Screw M3x8mm
(HC050-S)

CF Tail Plate
(H1096-01-S)

Metric Nylon Nut M3
(HC206-S)

Tail Fin
(H1096-02-S)

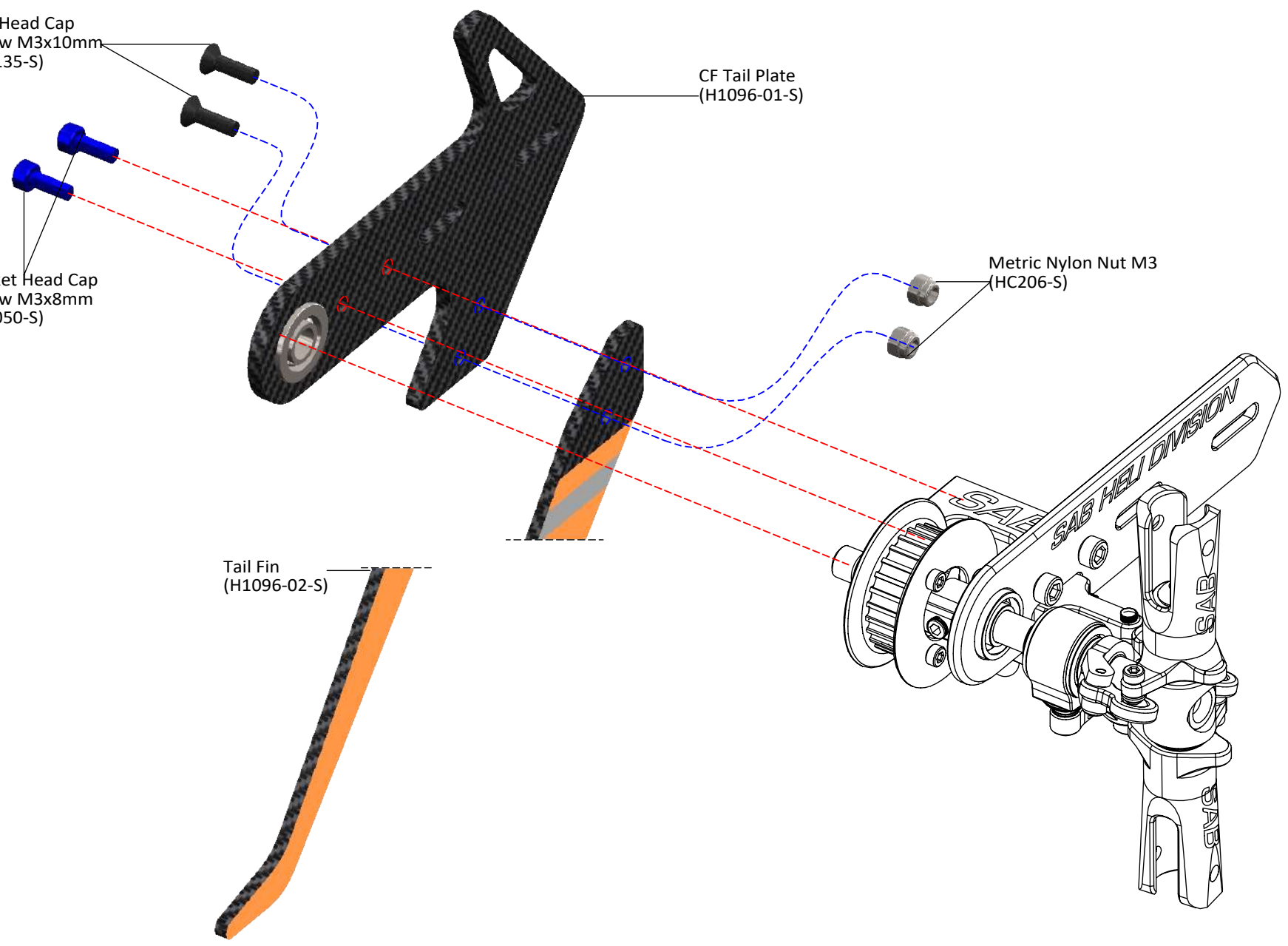

1

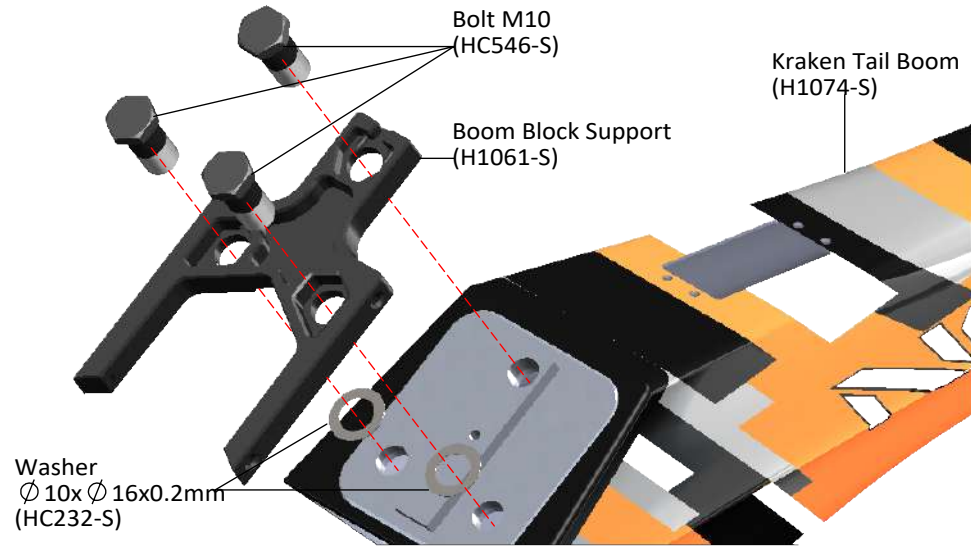

2

FOAM 1, BAG 12

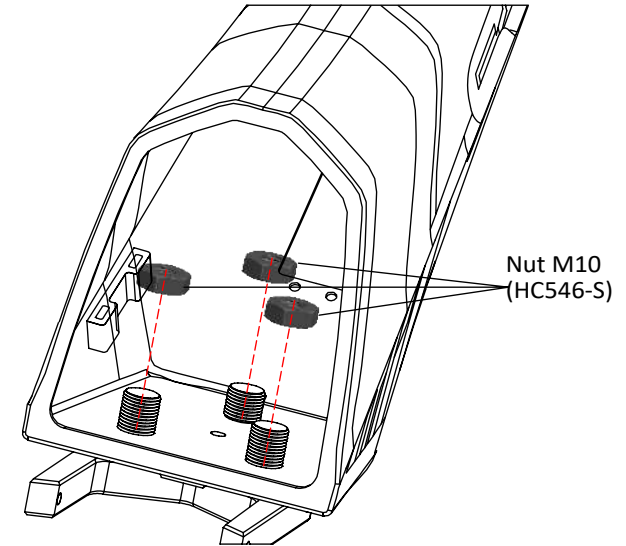

3

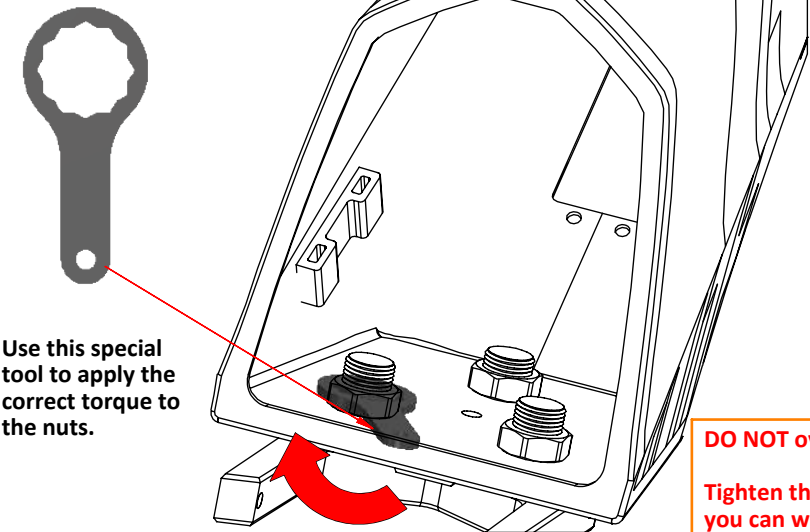

DO NOT over tighten the screw.
Tighten the bolts as tight as you can with your fingers, then add 2 quarter turns to finish tightening them.

4

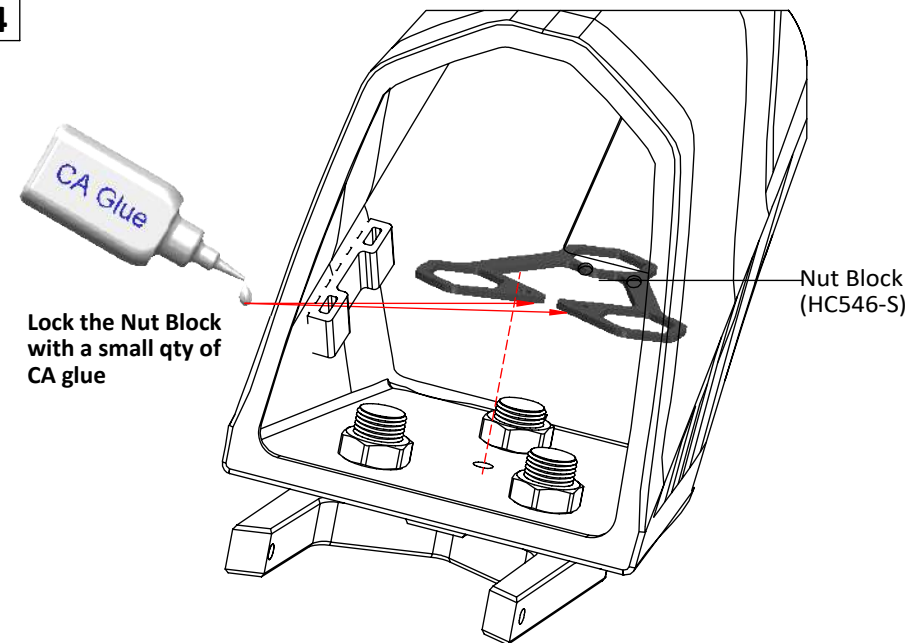

BAG 13

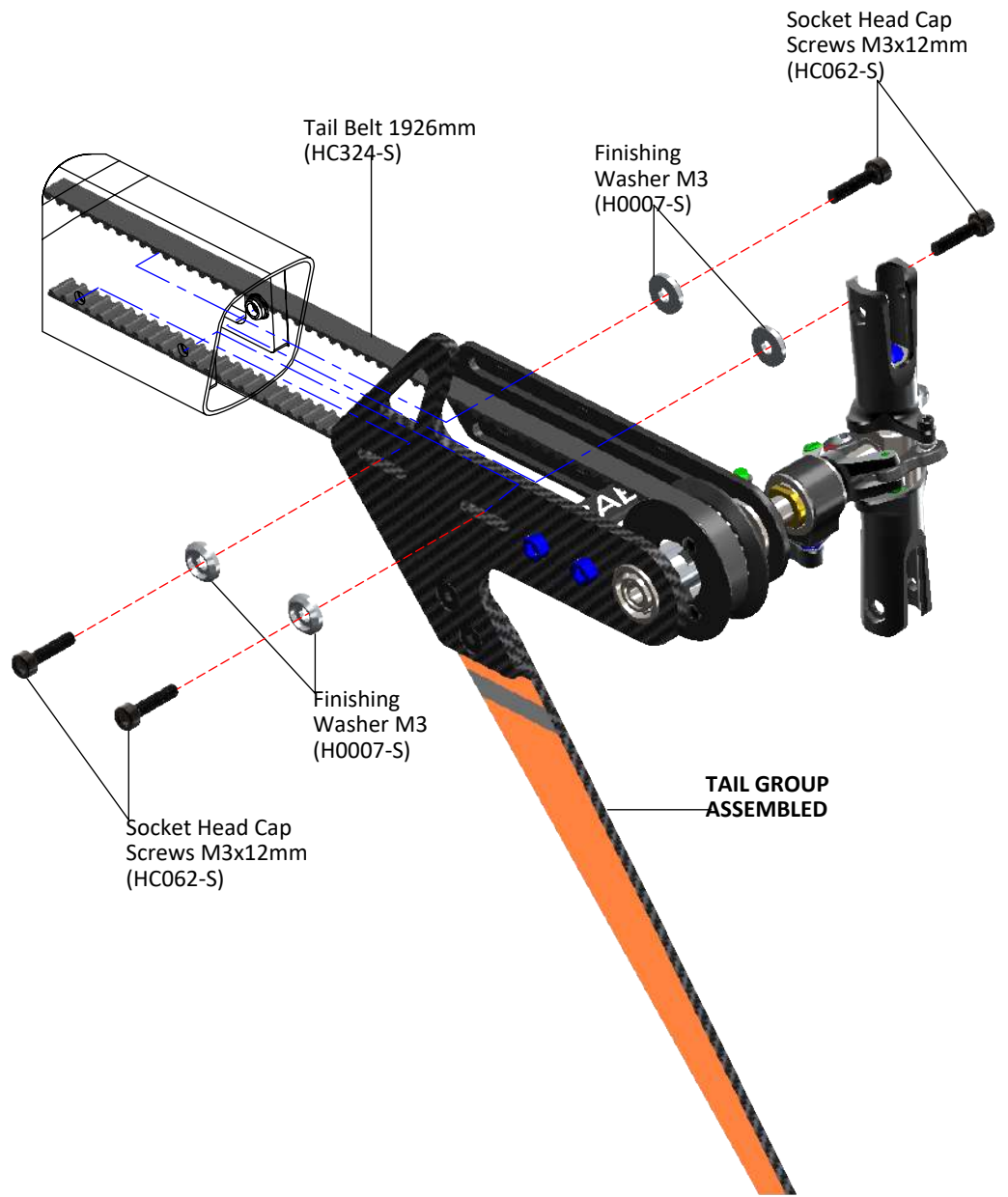
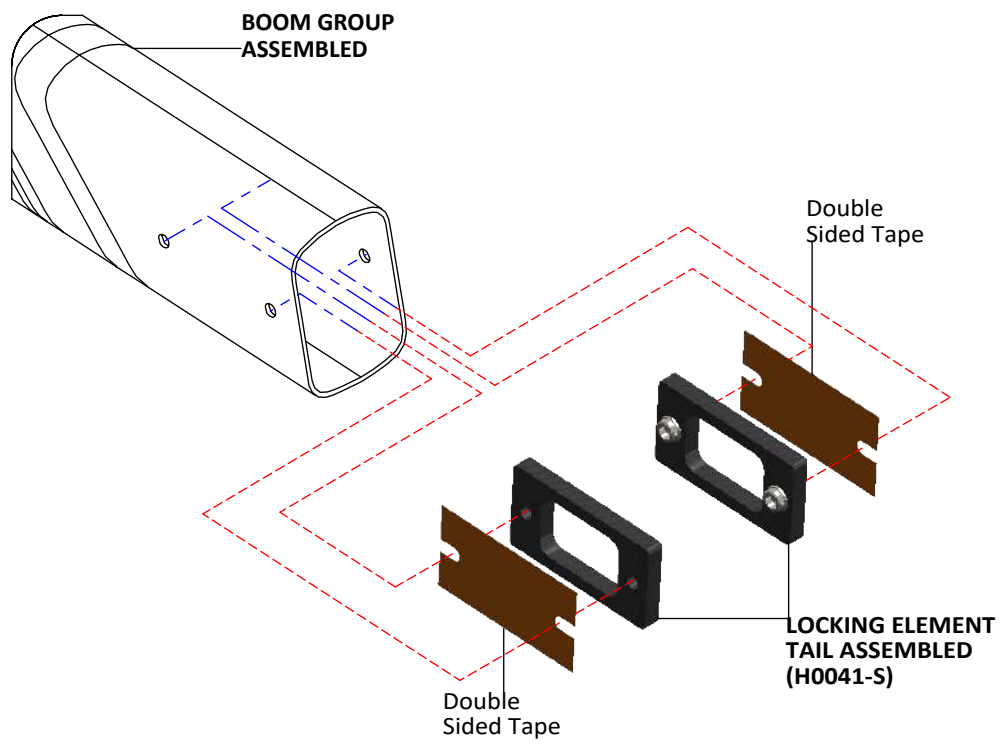

TAIL SERVO ASSEMBLY

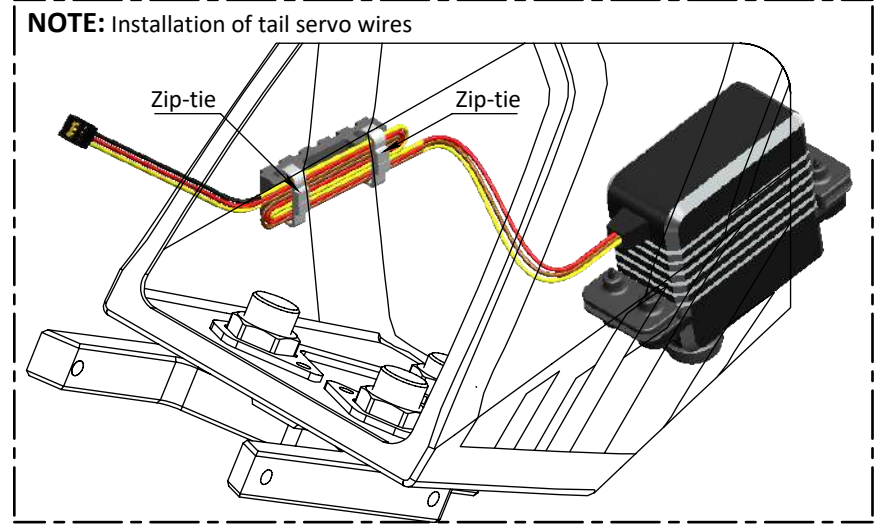
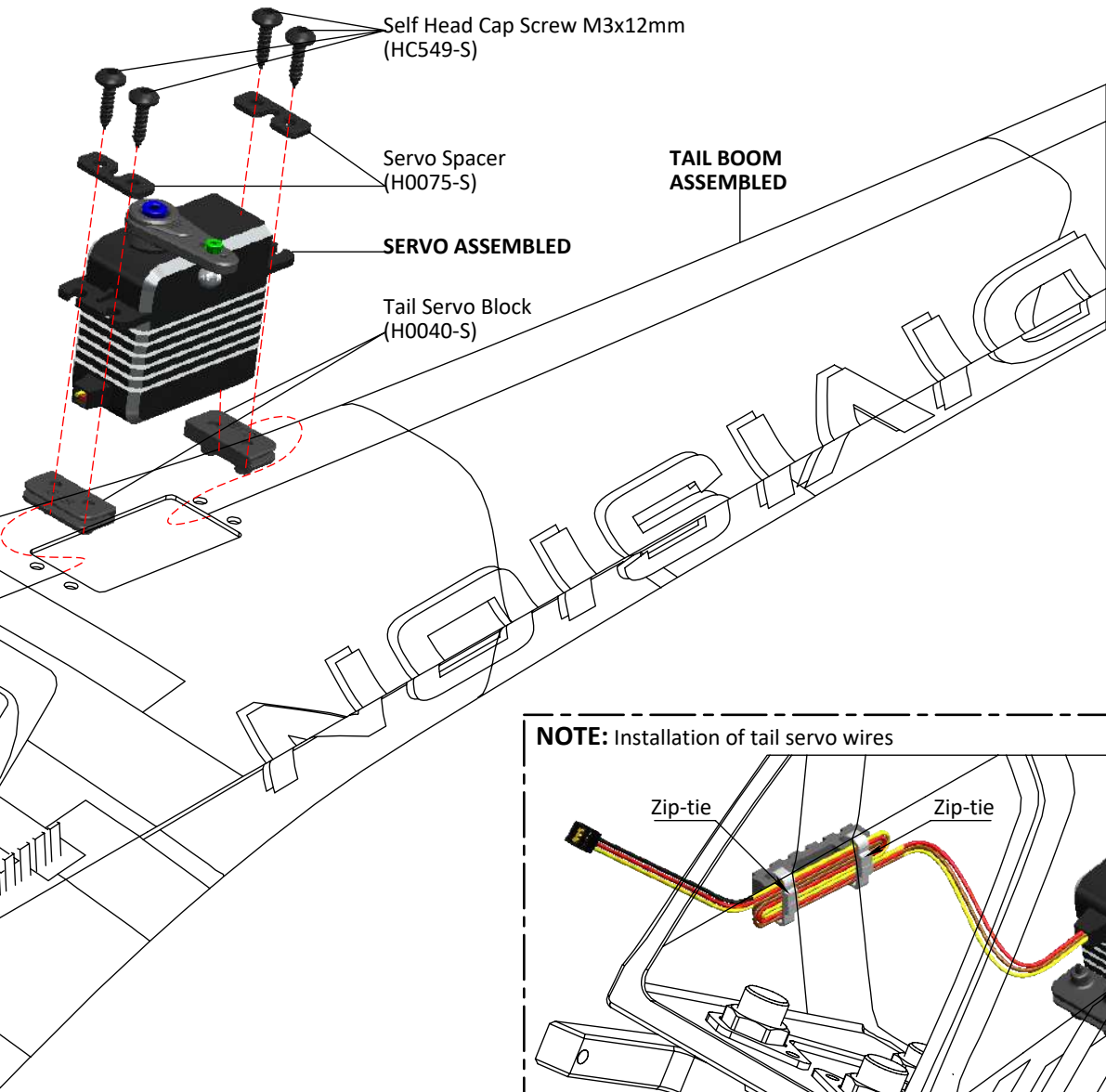
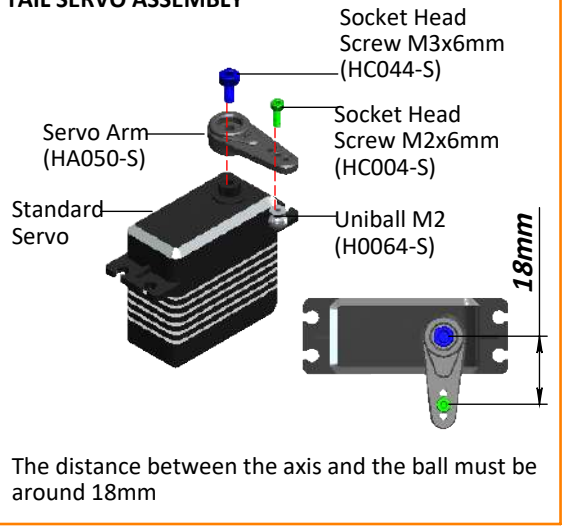

Before installing the plastic link on the threaded rod, be sure that you have waited at least 12 hours for the glue to fully cure.

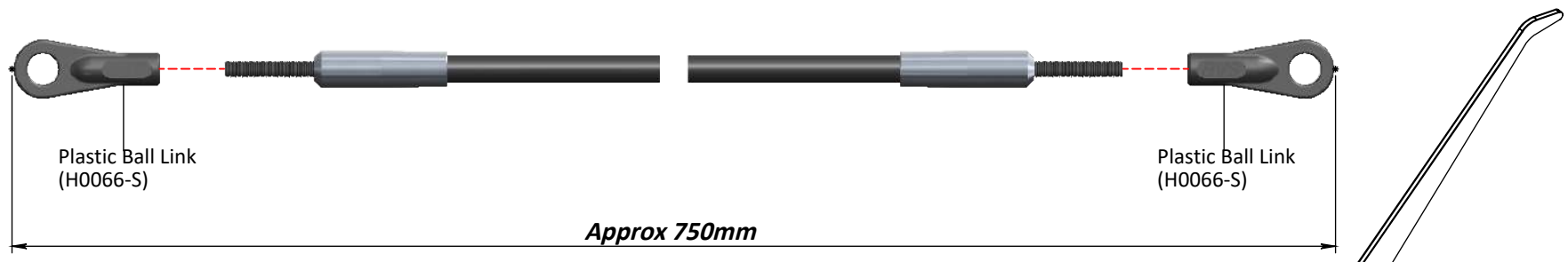

NOTE:
Before installing the plastic link onto the ball, be sure the tail push rod moves smoothly. You can open up H0045-S if you need to.

CARBON ROD ASSEMBLED

NOTE:
The carbon rod is slightly bent, generating a little preload against the carbon rod support. Check the movement of the rod. If it is a little tight you can enlarge the hole of the carbon rod support using a 5mm shaft.

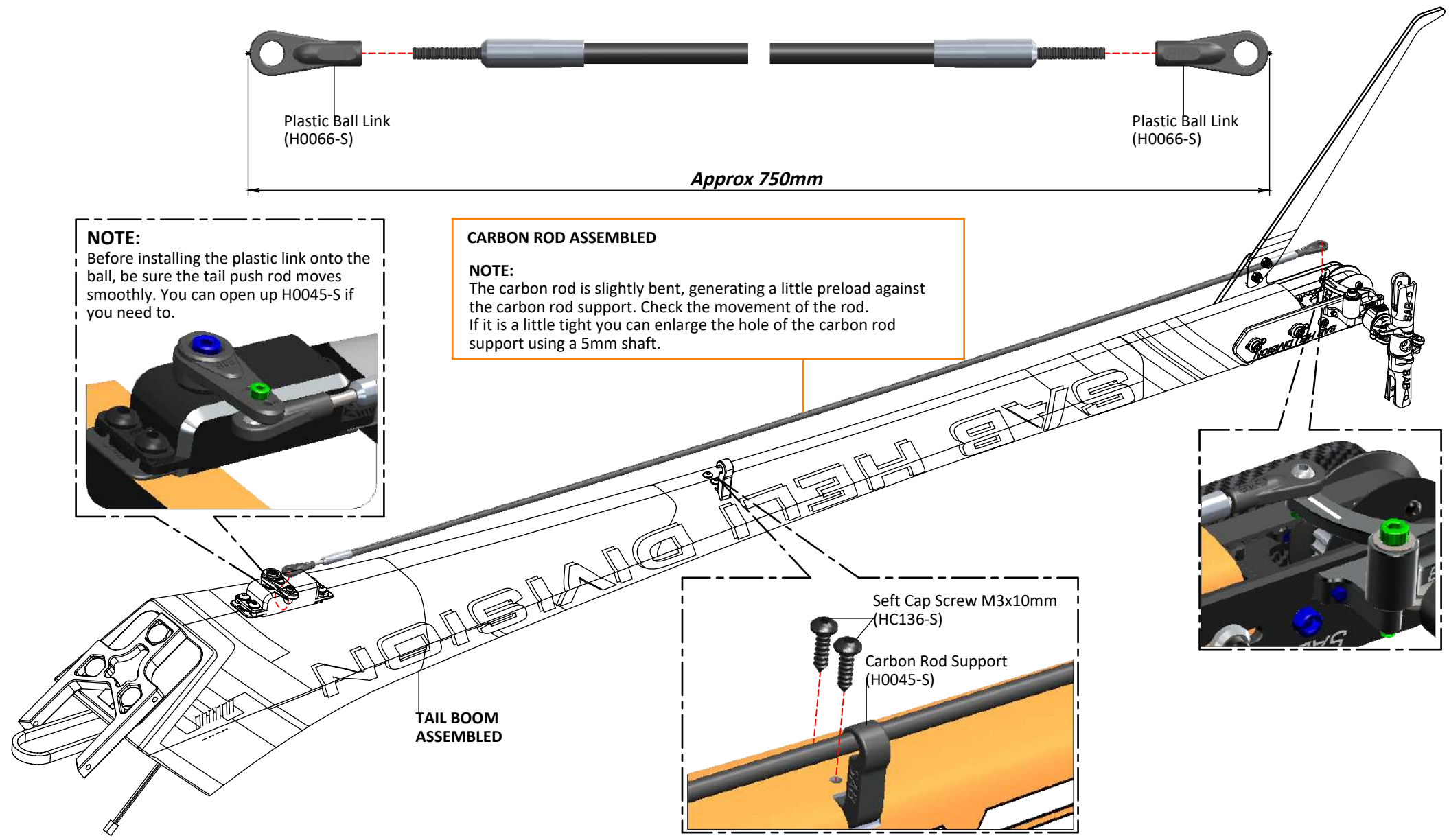

Soft Cap Screw M3x10mm (HC136-S)

Carbon Rod Support (H0045-S)

BAG 15

TAIL BOOM ASSEMBLY

To fit the tail belt, loosen the tail case by loosening the 4 M3 screws (Figure 1).

*Install the belt onto the tail front pulley, checking the direction of rotation.

*Insert and tighten the four M4 screws of the boom plate.

*Rotate the tail drive several times by hand.

*Tension the tail case by hand and slowly tighten the 2 BLACK screws in (Figure 2).

NOTE: To disassemble the tail boom, you have to remove the 4 M4 screws. **DO NOT** loosen the 3 M10 plastic screw.

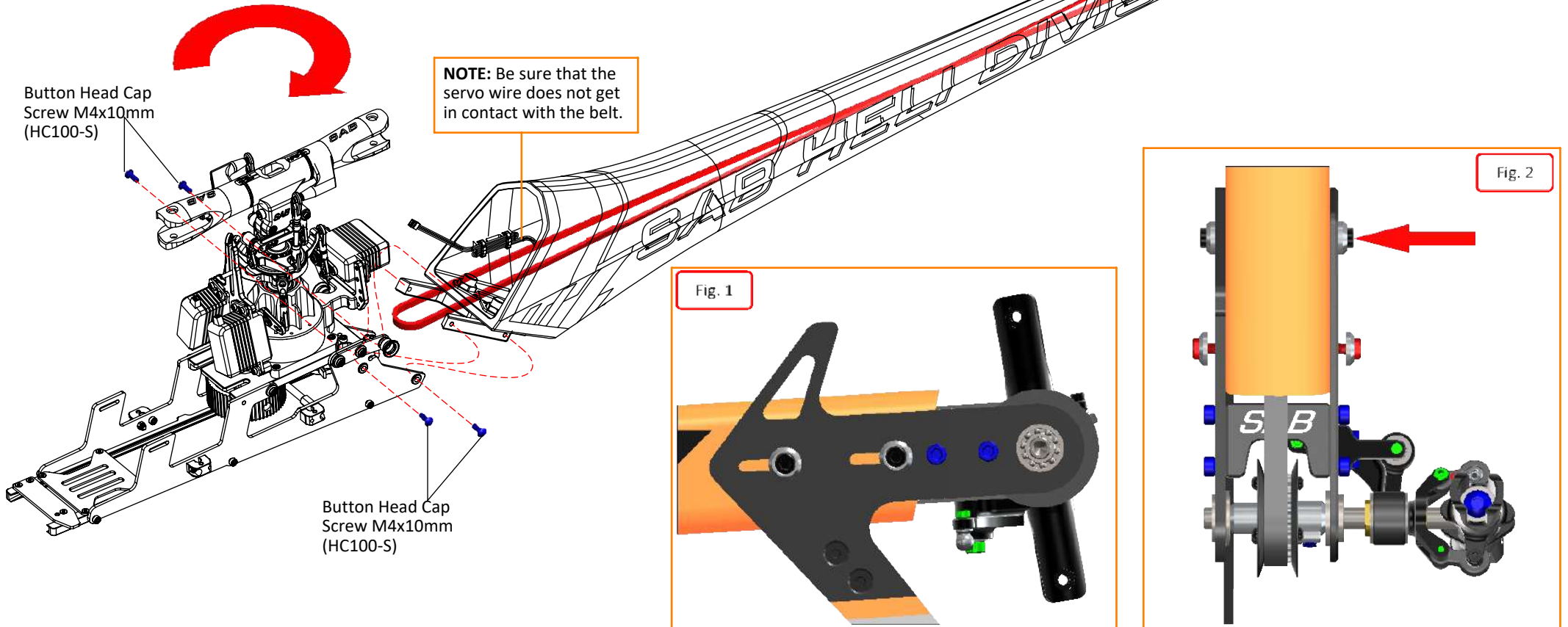

TAIL BELT TENSION

To provide the correct tail belt tension, you can use the "zig-zag" method.

Figure 1, Loosen the 2 **RED** screws and the **BLUE** and push the tail side in according with red arrow. Tighten the **BLUE** screw while you are pushing.

Figure 2, Loosen the 2 **RED** screws and the **YELLOW** and push the tail side in according with red arrow. Tighten the **YELLOW** screw while you are pushing.

You can proceed step by step until the tail belt is tight enough.

Hard 3D style will require more tension; Sport flight style less.

When you set your perfect tension, you can tighten all screws making sure the tail shaft is perfectly straight.
(**Figure 3**, tail output shaft have to be perpendicular to the boom mid line).

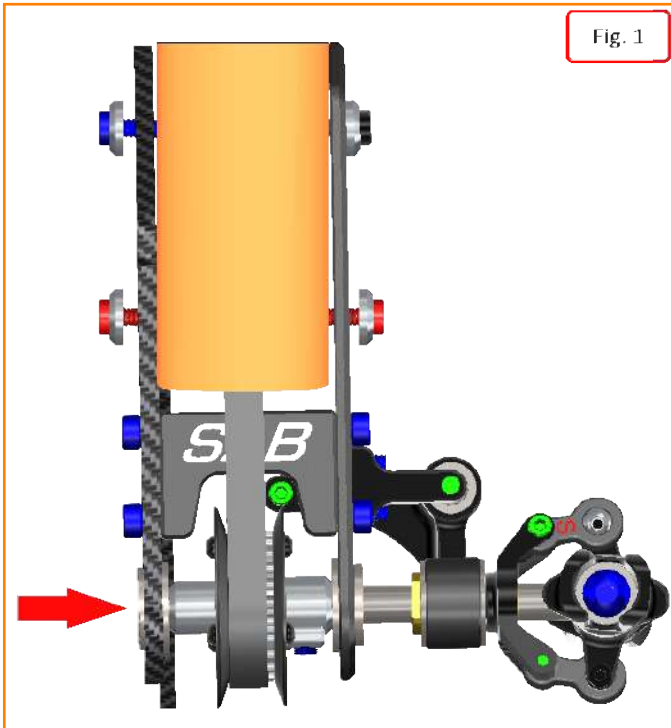

Fig. 1

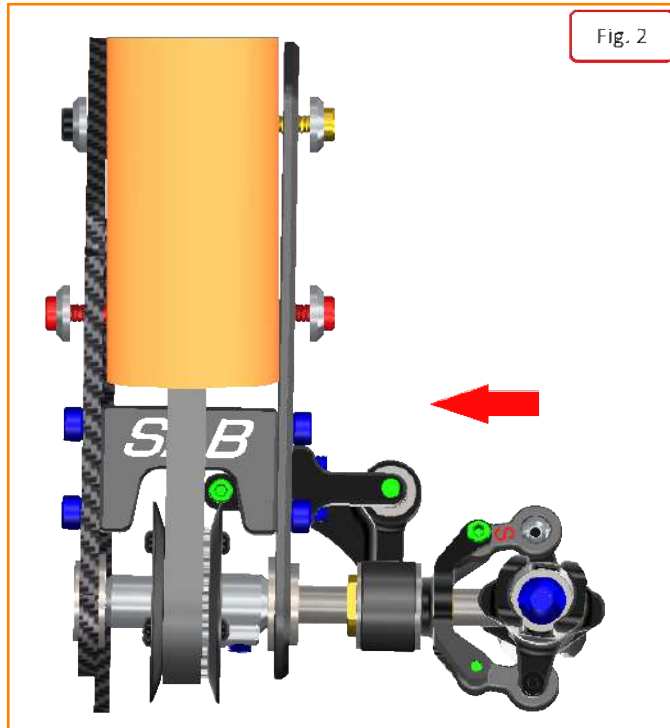

Fig. 2

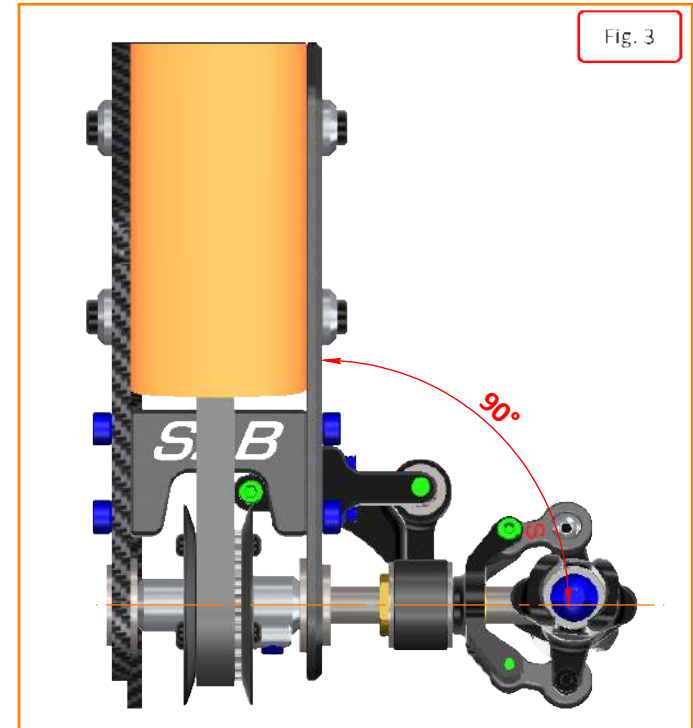
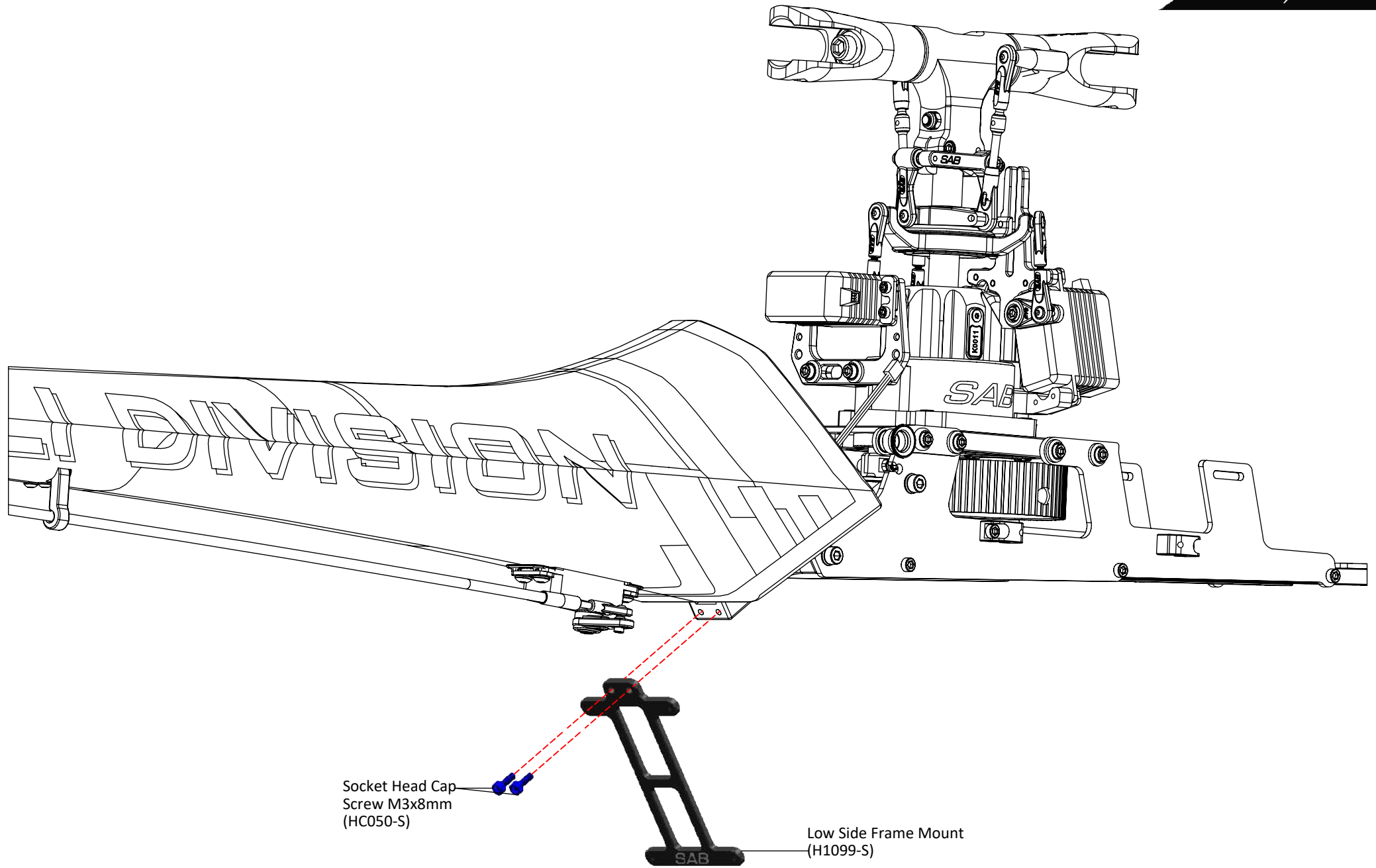
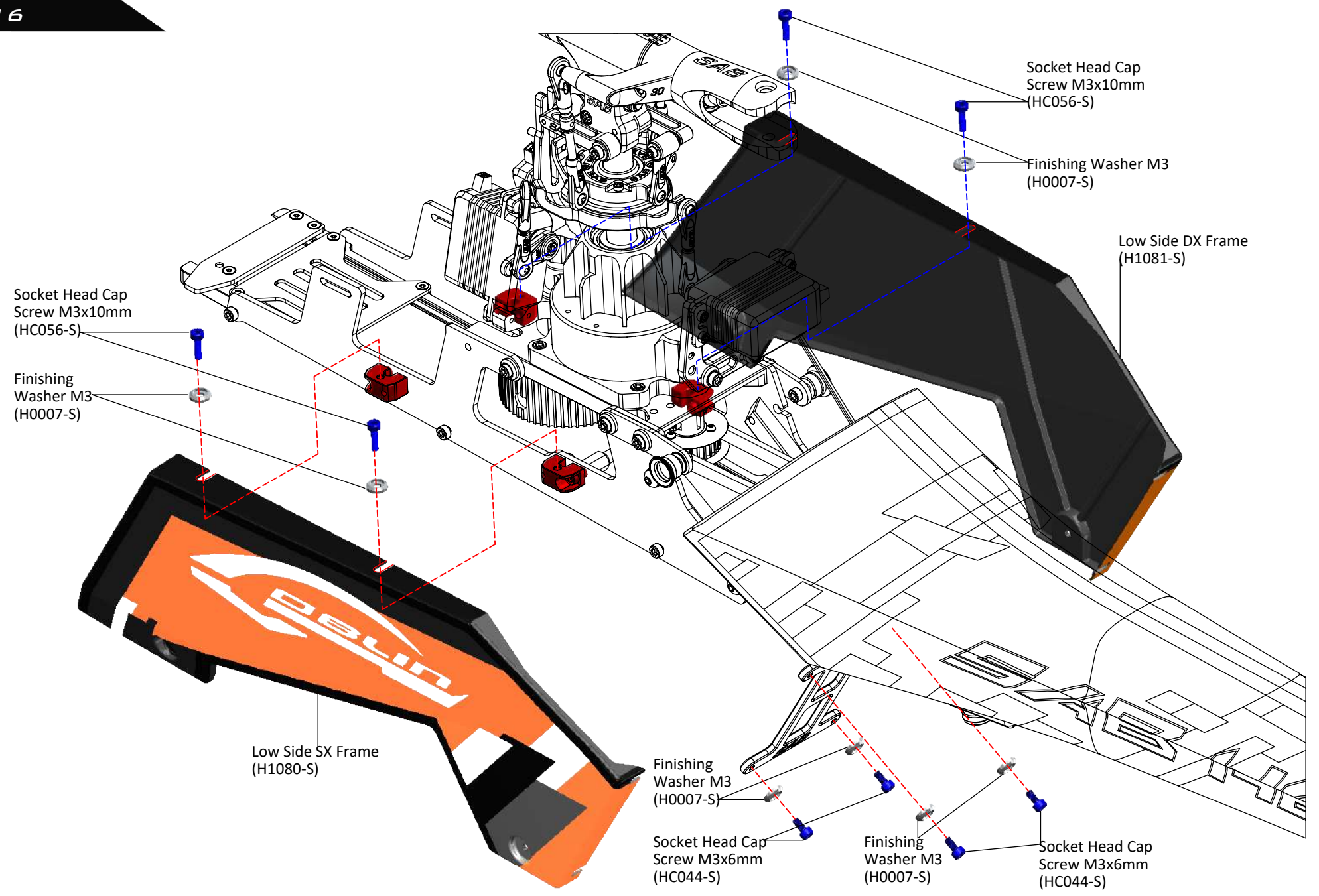

Fig. 3



Socket Head Cap
Screw M3x8mm
(HC050-S)

Low Side Frame Mount
(H1099-S)



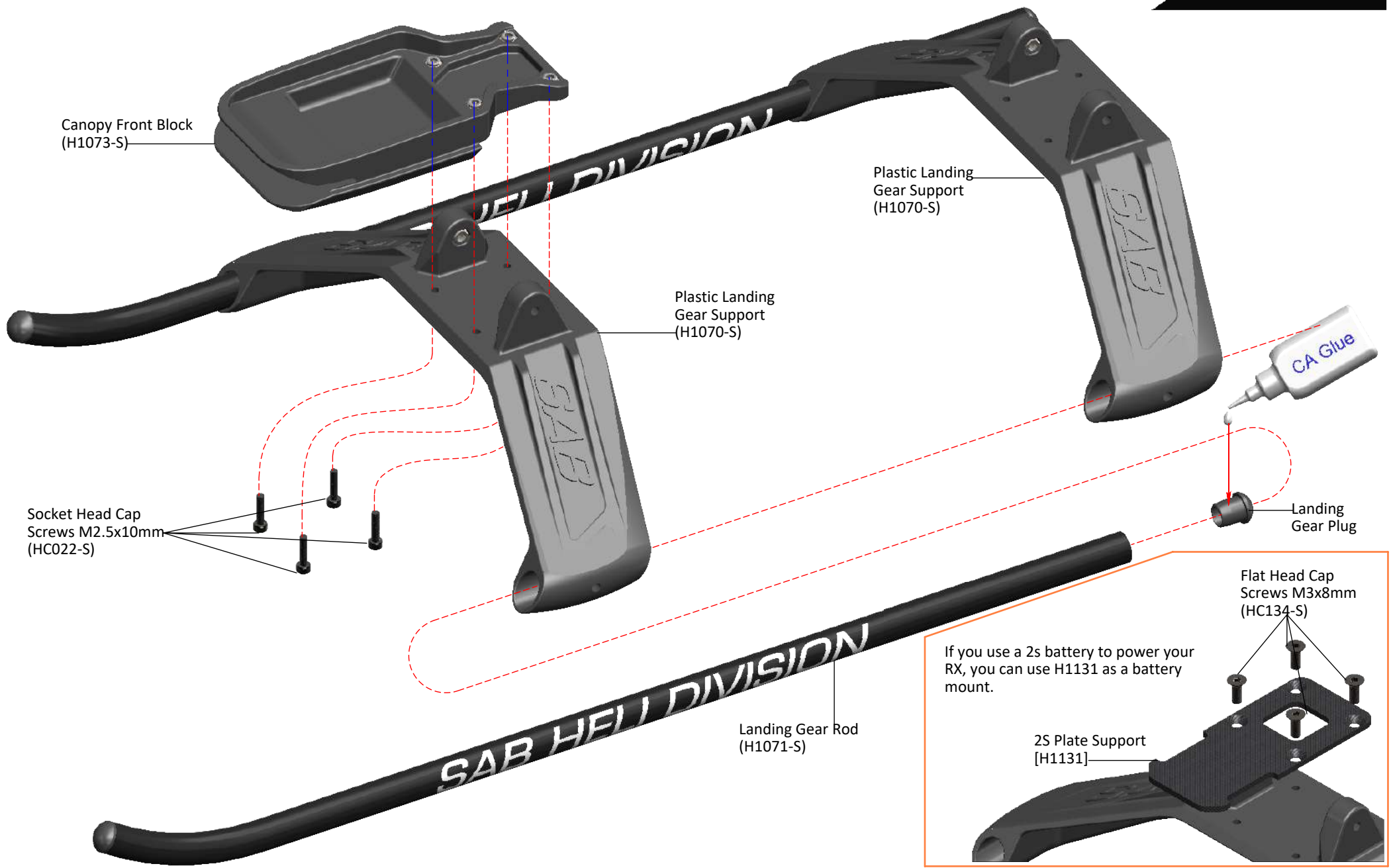

Canopy Front Block (H1073-S)

Plastic Landing Gear Support (H1070-S)

Plastic Landing Gear Support (H1070-S)

Socket Head Cap Screws M2.5x10mm (HC022-S)

Landing Gear Plug

Flat Head Cap Screws M3x8mm (HC134-S)

Landing Gear Rod (H1071-S)

If you use a 2s battery to power your RX, you can use H1131 as a battery mount.

2S Plate Support [H1131]

BAG 18

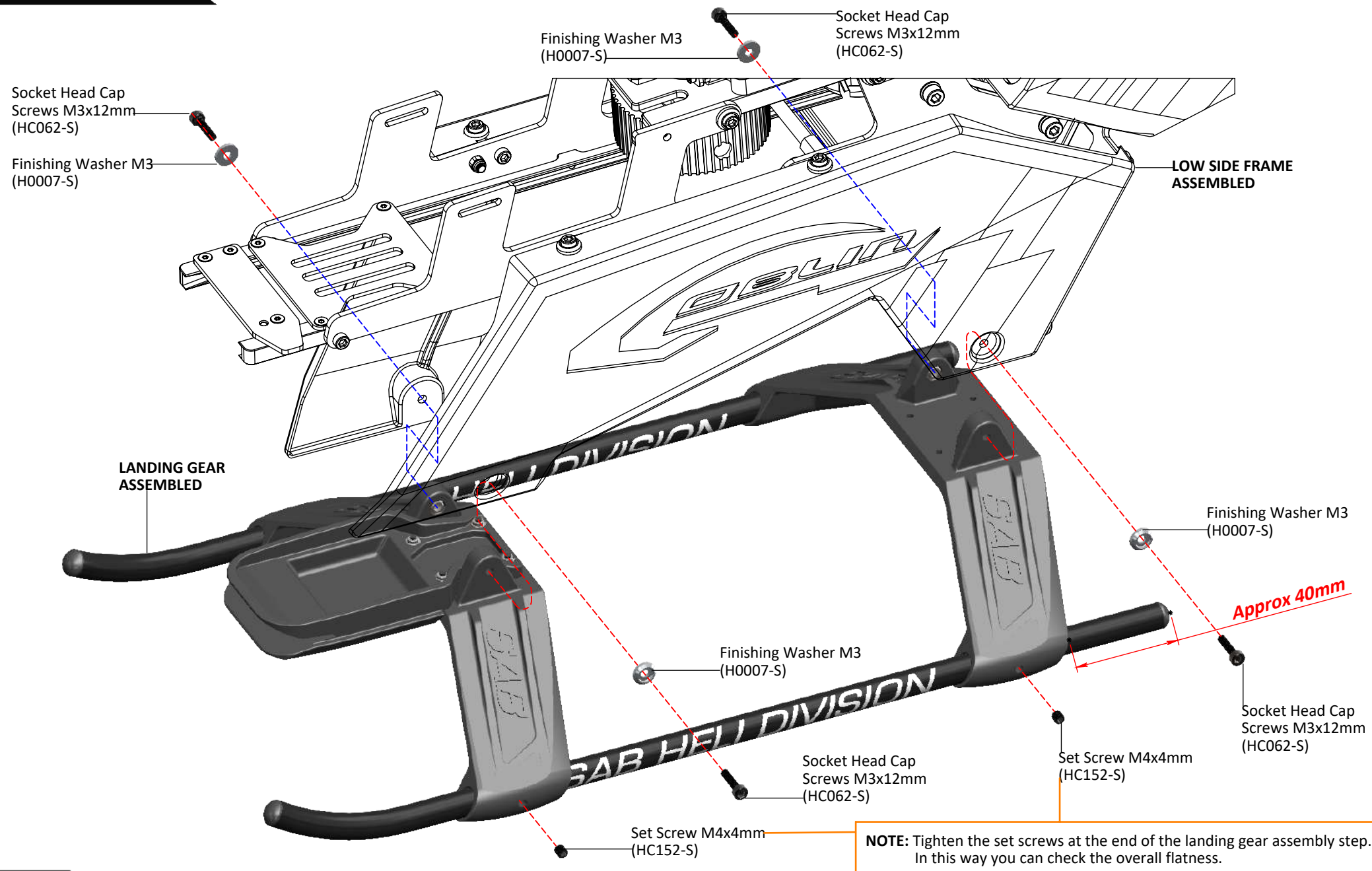

TRANSMISSION SETUP

It is important to choose the right reduction ratio to maximize efficiency based on your required flight performance.

It is recommended to use wiring and connectors appropriate for the currents generated in a helicopter of this class.

If you are using a head speed calculator which requires a main gear and pinion tooth count, use 216 teeth for the main gear (this takes into account the two stage reduction) and the tooth count of your pulley as the pinion count.

BELOW IS A LIST OF AVAILABLE REDUCTION RATIOS:

H0175-18-S - **18T** Pinion = ratio **12.1:1**

H0175-22-S - **22T** Pinion = ratio **9.9:1**

H0175-19-S - **19T** Pinion = ratio **11.5:1**

H0175-23-S - **23T** Pinion = ratio **9.5:1**

H0175-20-S - **20T** Pinion = ratio **10.9:1**

H0175-24-S - **24T** Pinion = ratio **9.1:1**

H0175-21-S - **21T** Pinion = ratio **10.4:1**

H0175-25-S - **25T** Pinion = ratio **8.7:1**

GOBLIN KRAKEN CONFIGURATIONS					
Battery	Motor	ESC	Pinion (a, b)	RPM Max (a, b)	Pitch
12S 4200/5500 mAh	Xnova 4525-530kv lightning	HW-200A	21T / 22T	2100/2200	± 12
	Pyro 750-560	Kosmik 160	20T / 21T		
	Scorpion HKII 4525-520 UL	YGE Aureus 135 SCORPION II 14-200A	22T / 23T		
12S 4500/5500 mAh	Xnova 4530-525kv lightning	HW-200A	22T / 23T	 2200/2300	± 13
	Pyro 800-480	Kosmik 200	24T / 25T		
	Scorpion HKII 4530-540	YGE 205HVT SCORPION II 14-200A	21T / 22T		

Rev:01

FOAM 1, BAG 19

3rd bearing support for the motor, H0143-S
Install the support after installing the pulley and after mounting the motor.
H0143 does not need to be used with an 8mm motor shaft.

Set Screw M4x4mm or M4x6
in according with motor pulley/shaft
(HC152-S)/(HC153-S)

The set screw must be under the
surface of the teeth.

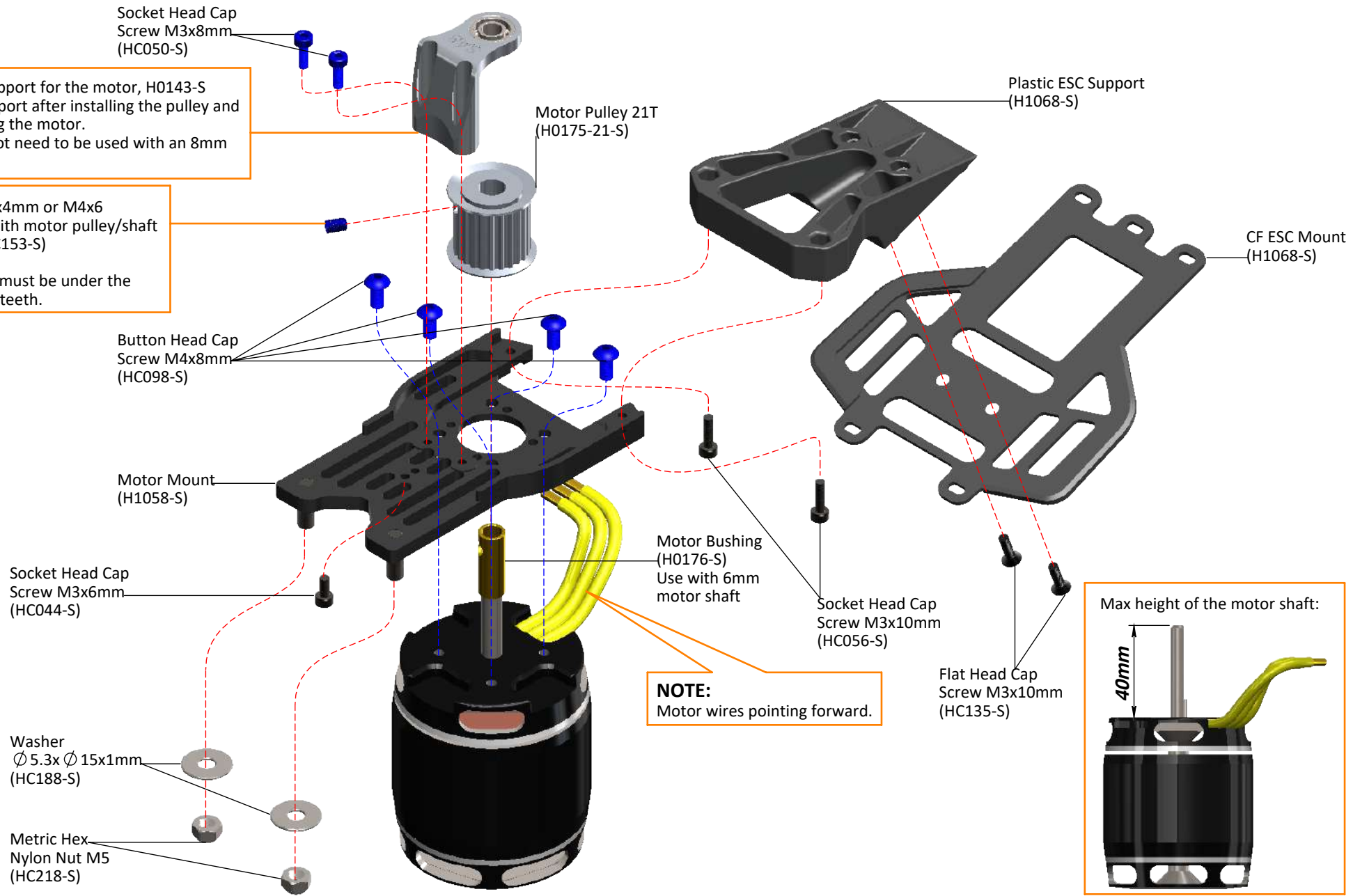

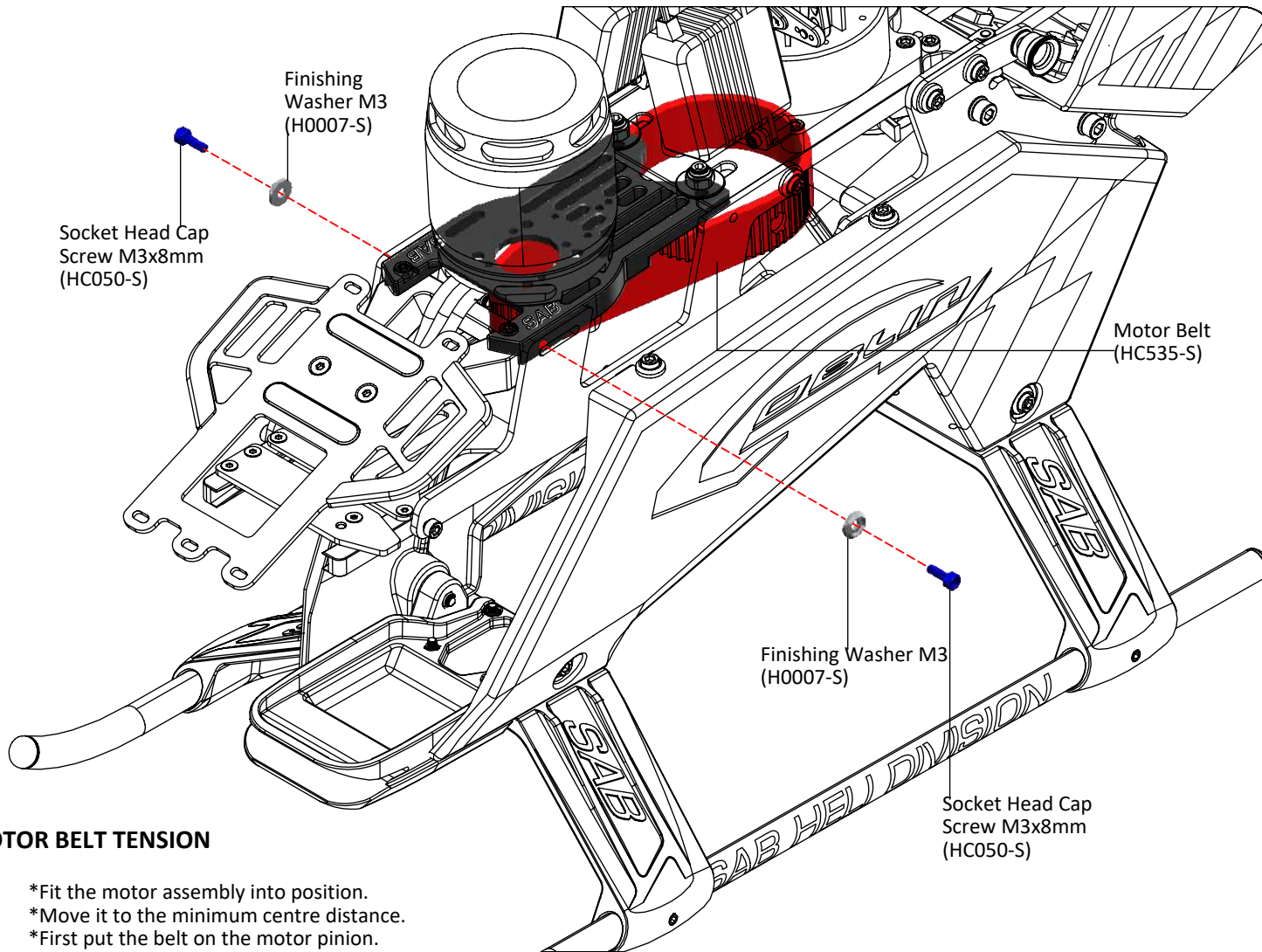

MOTOR BELT TENSION

- *Fit the motor assembly into position.
- *Move it to the minimum centre distance.
- *First put the belt on the motor pinion.
- *Then put the belt around the big pulley.
- *Rotate the motor several times by hand.
- *Pull on the motor mount to tension the belt.
- *Rotate again the motor several times by hand.
- *Provide the correct force, and properly tension the belt.
- *Tighten the M5 nuts first, then the (2) M3 screws later.

BAG 2 1

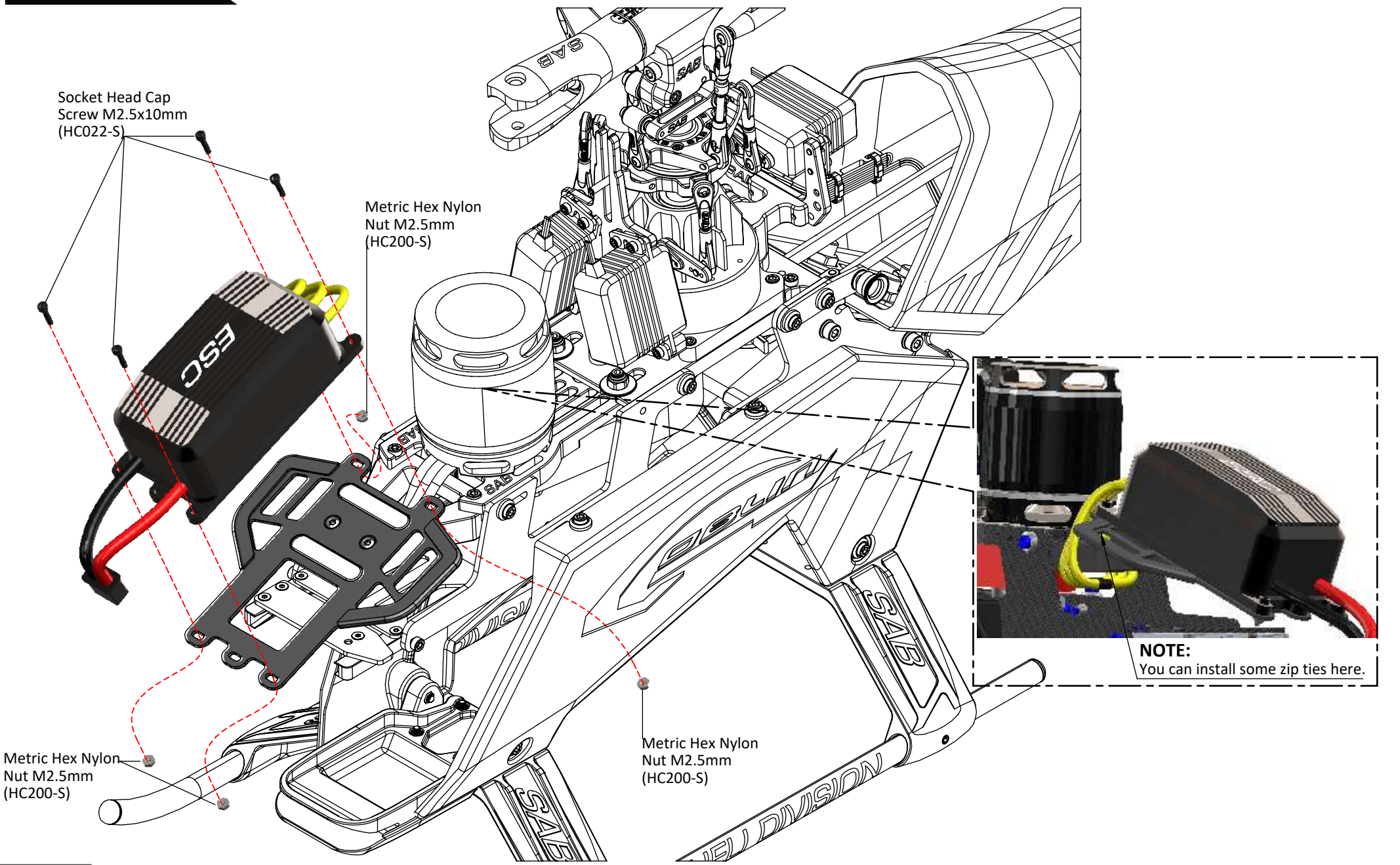

FBL SUPPORT STANDARD OPTION (OPTION 1)

NOTE:
2mm thick tape for the gyro is recommended.

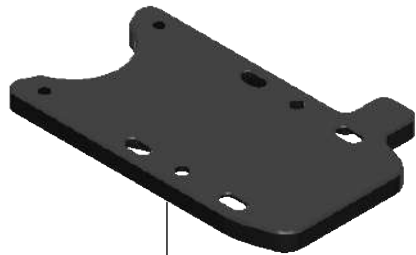

FBL Support (H1103-S)

IF YOU USE FBL AND SEPARATE RX (OPTION 2)

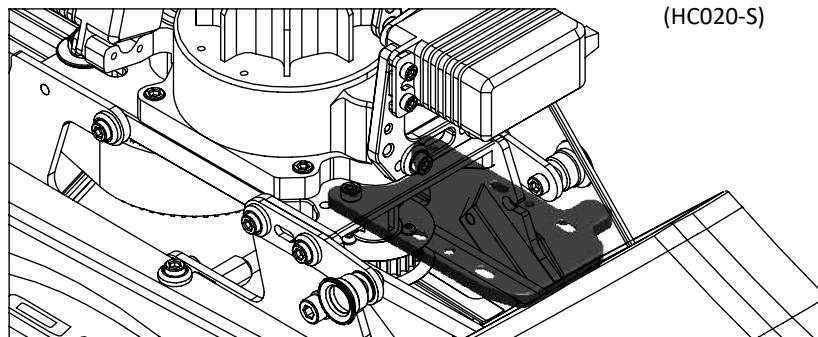
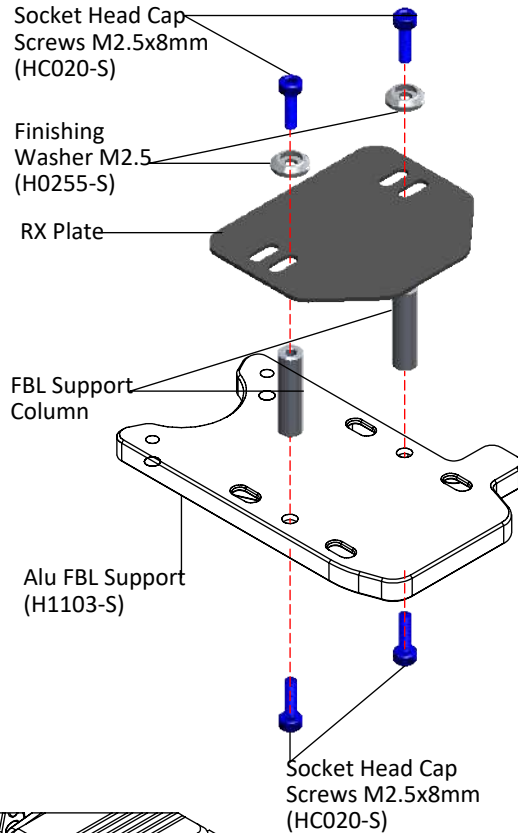

OPTION WITH SIDE CONNECTION Offers greater vibration isolation (OPTION 3)

NOTE:
2mm thick tape for the gyro is recommended.

Replace H1113 with H1179.

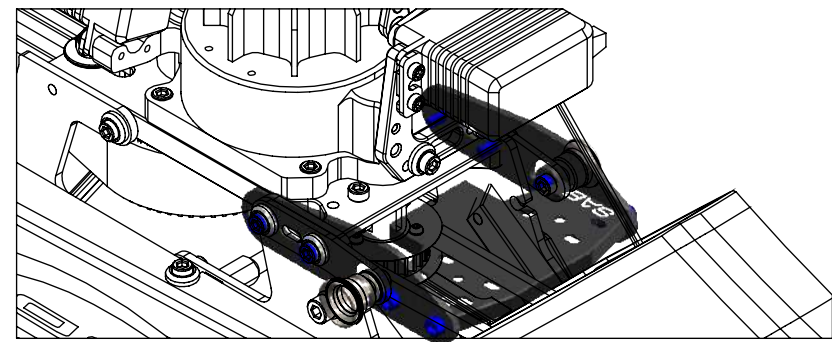
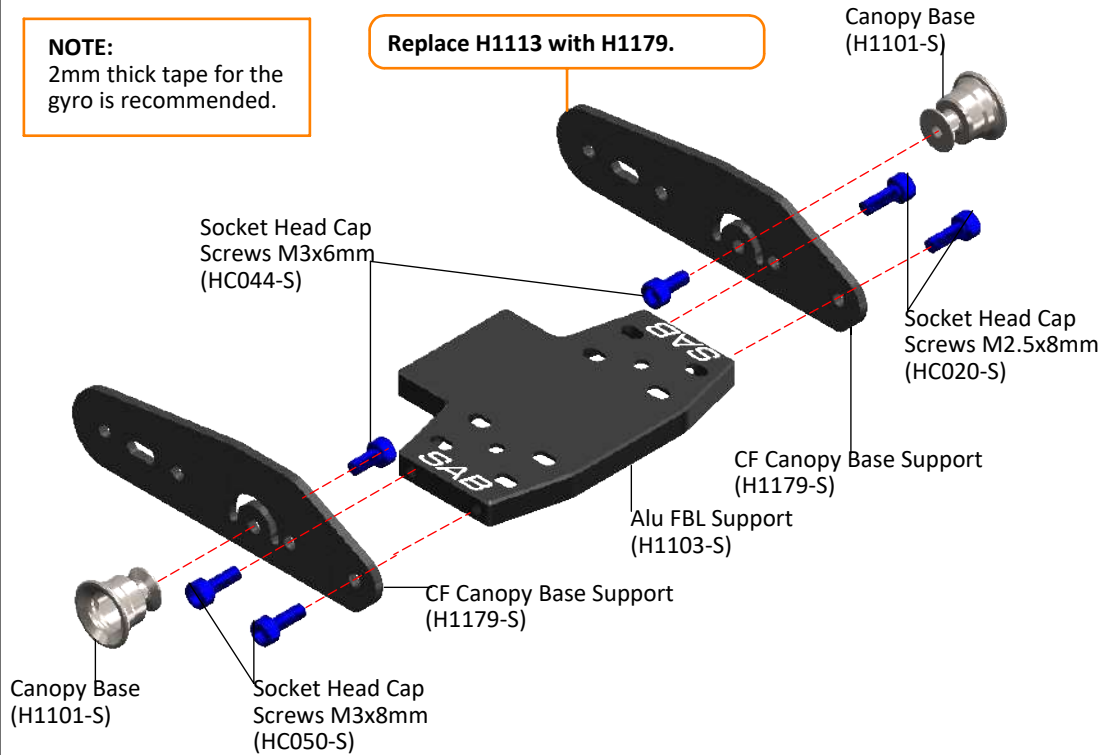

BAGS 23, 28

In bag 28, you can find a "3D Printed" antenna support. Use it as desired with your RX system.

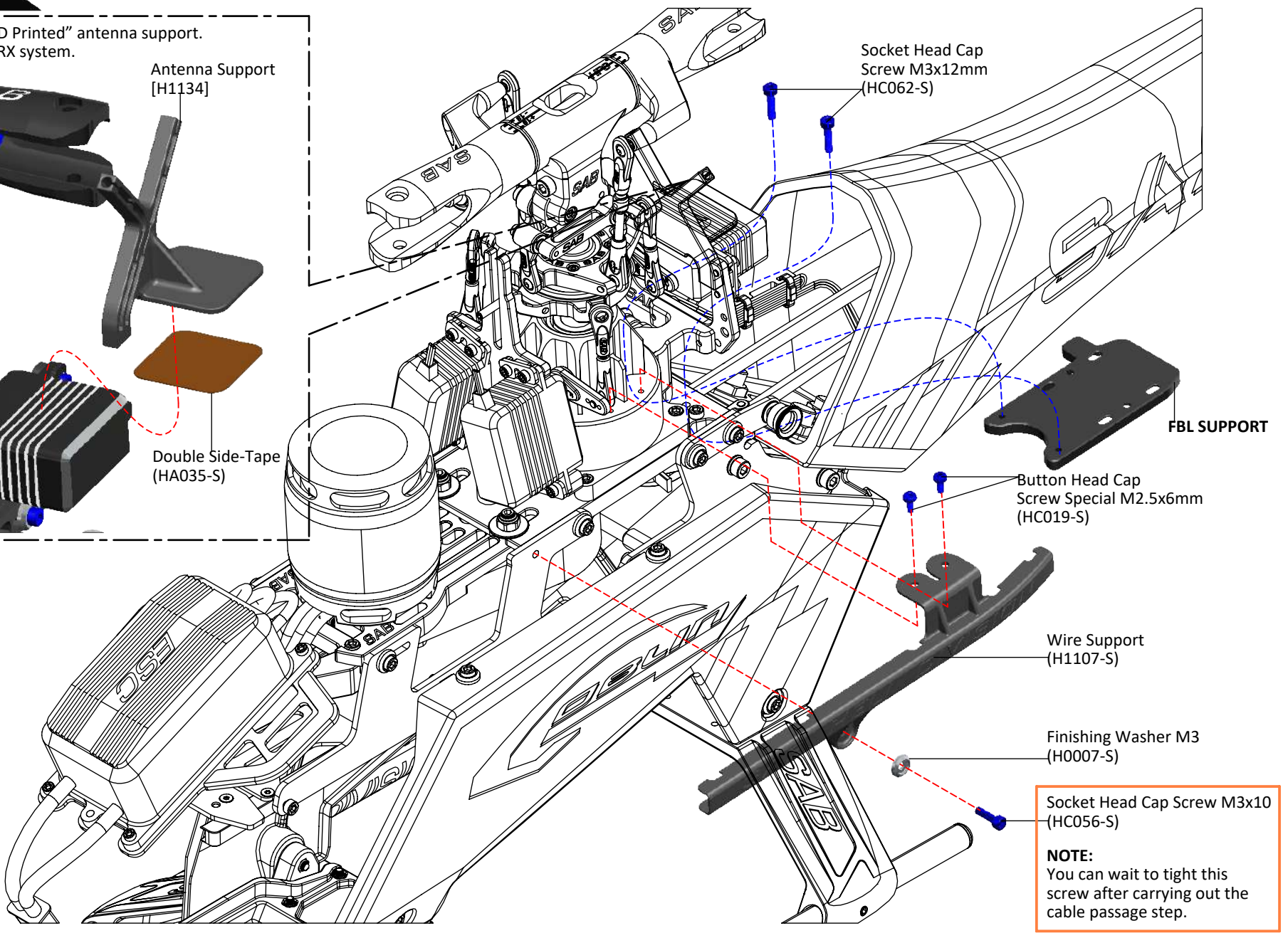
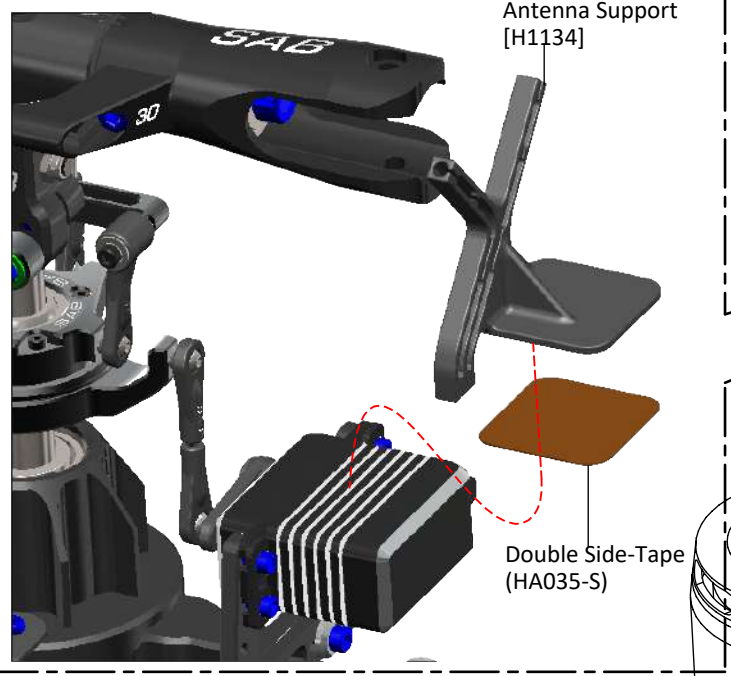

NOTE:
You can wait to tight this screw after carrying out the cable passage step.



Use hot glue to secure the wire connections.

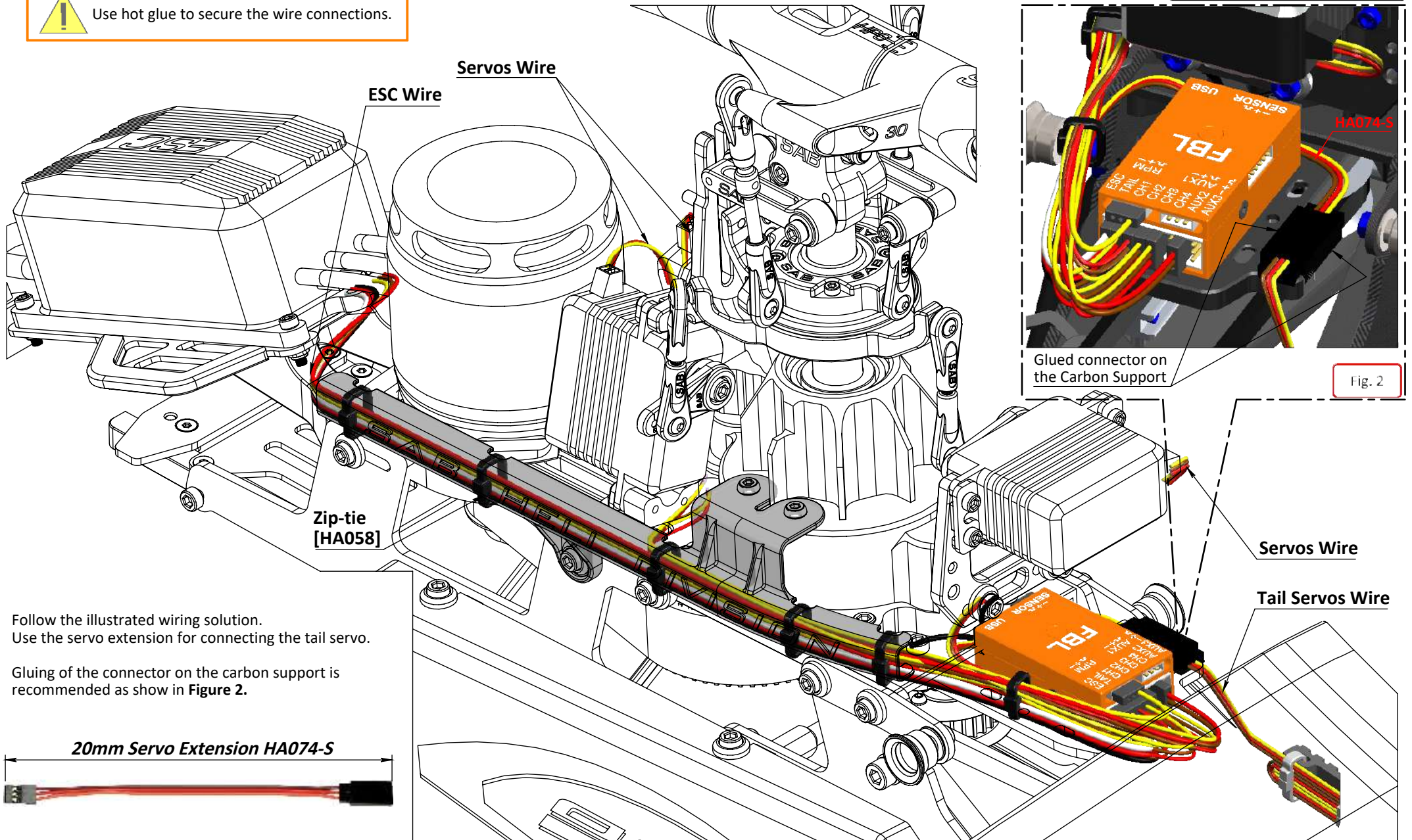

Follow the illustrated wiring solution.
Use the servo extension for connecting the tail servo.

Gluing of the connector on the carbon support is recommended as show in **Figure 2**.

BAG24

 Before permanently mounting the batteries onto the battery tray, check the ideal position for the best center of gravity.

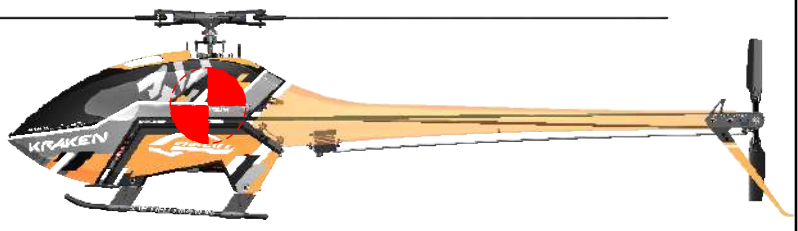

BATTERIES

Use the included double side tape to secure the batteries to the tray.
Use the Velcro Strap [HA041-S].

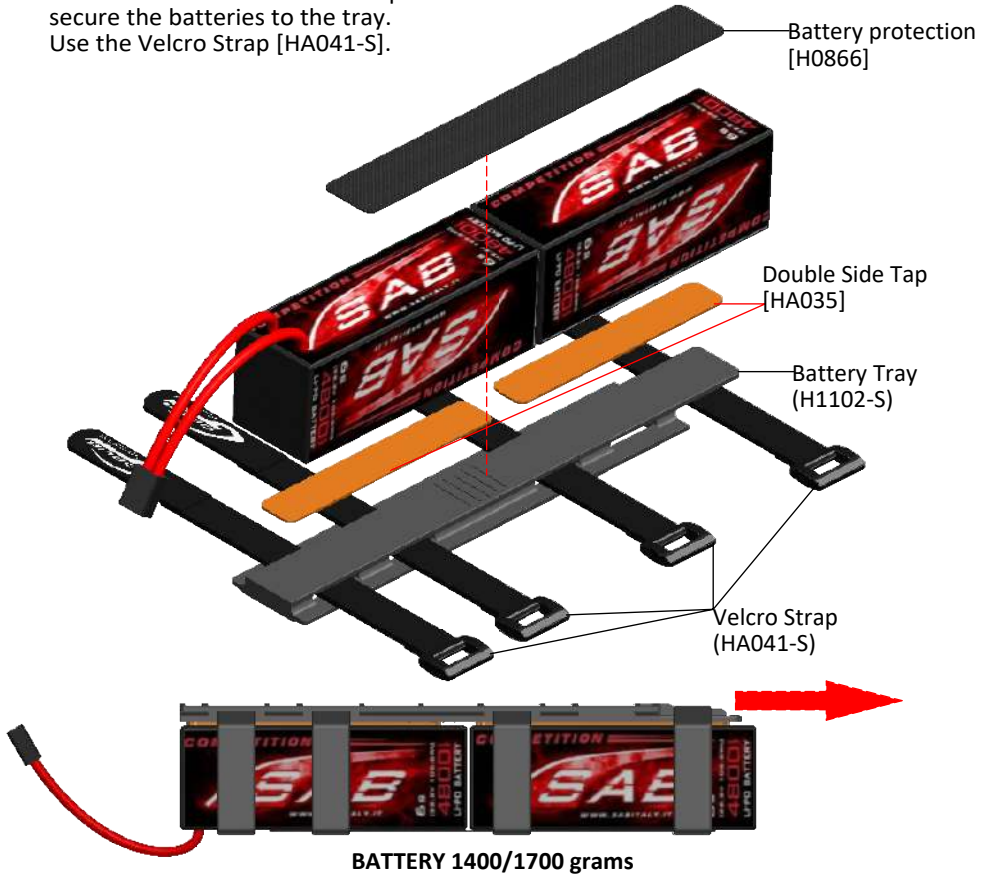

IMPORTANT 

Before flying, make sure that the locking pin is back in its resting position, blocking the battery tray in the correct position

NOTE:
With the eccentric bushing you can adjust the tray play.

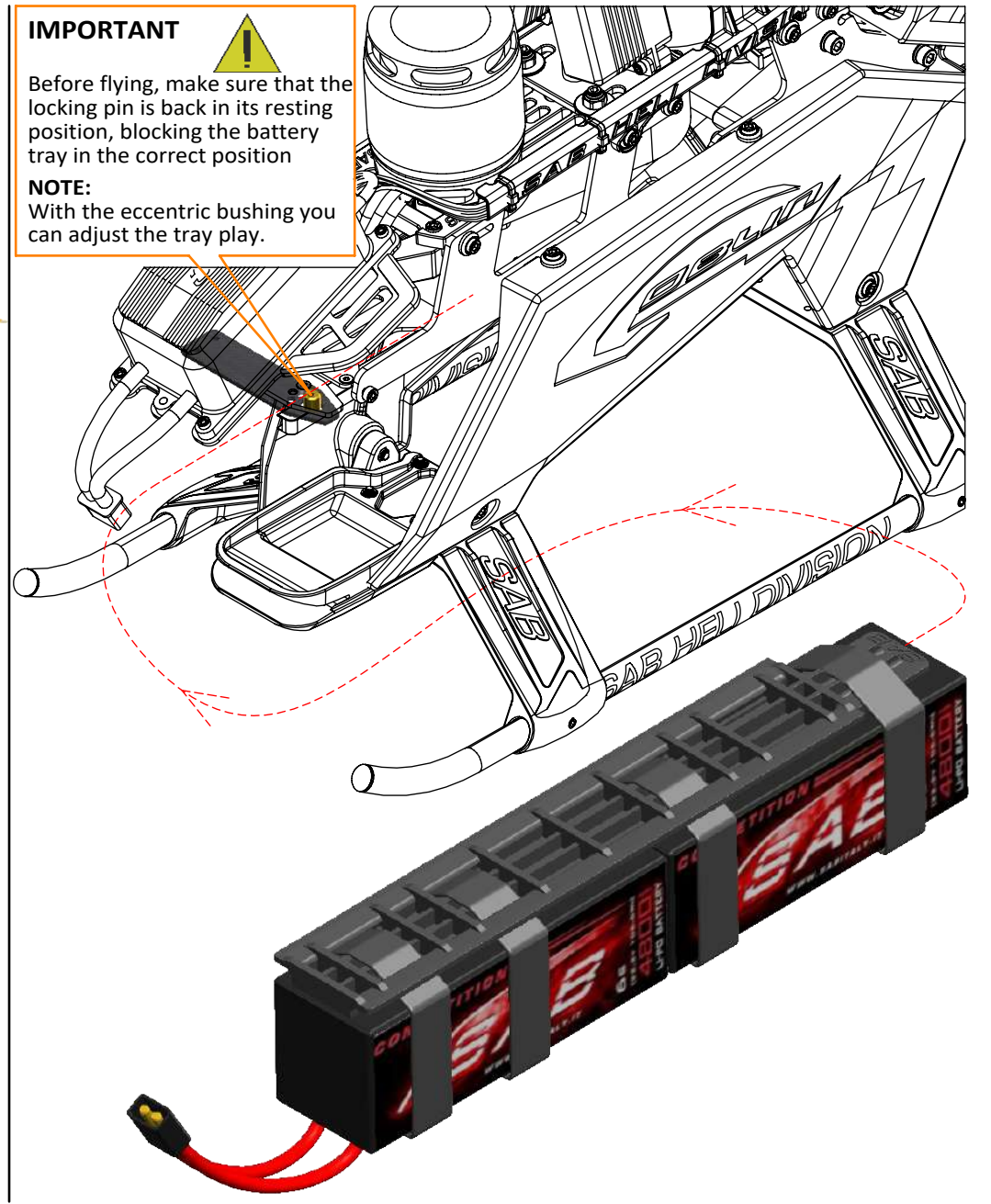

CANOPY

*Install Canopy grommets (**Figure.1**) and the two quick knobs (**Figure.2**)

*Fit the canopy in the red arrow zone, and insert the knobs.

 *Confirm the canopy is secure prior to each flight.

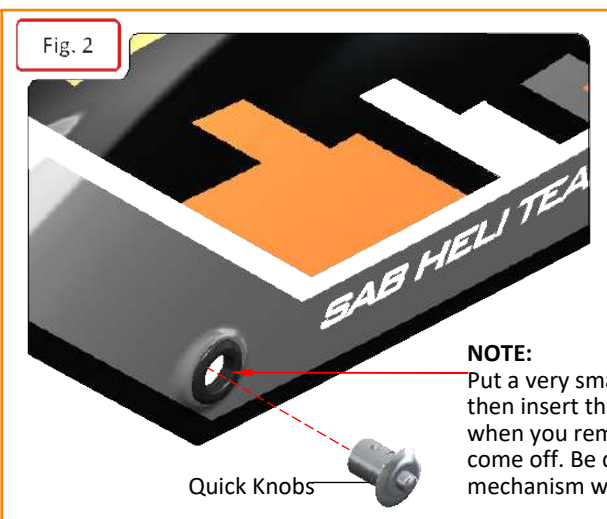
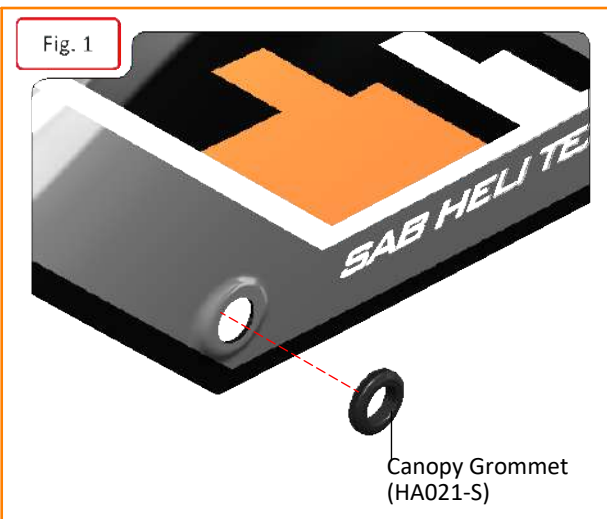

NOTE:
Put a very small drop of CA glue on the grommet and then insert the quick release canopy mount. This way when you remove the canopy, the mounts can not come off. Be careful not to block the quick release mechanism with glue.

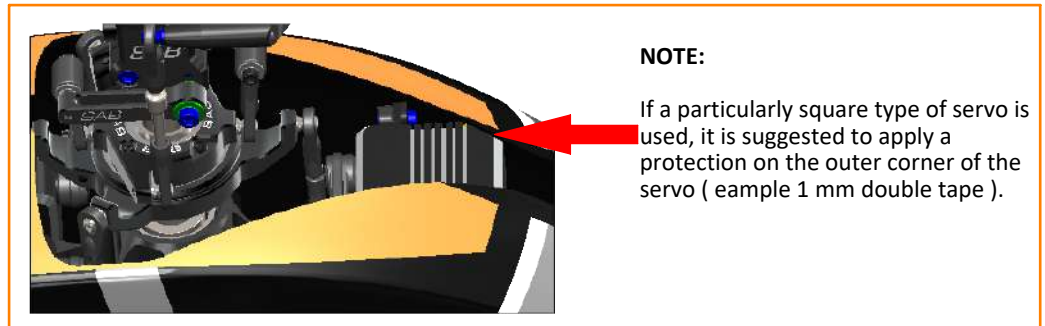

NOTE:
If a particularly square type of servo is used, it is suggested to apply a protection on the outer corner of the servo (eample 1 mm double tape).

BAG 26

OPERATIONS BEFORE FLIGHT

- *Set up the remote control and the flybarless system with utmost care.
- *It is advisable to test the correct settings of the remote and flybarless system without main blades or tail blades fitted.
- *Check that all wiring is isolated from the carbon/aluminum parts. It is good practice to protect them at the points where they are at most risk.
- *Be sure of the gear ratio, verifying carefully the motor pulley in use. The forces acting on the mechanics increase enormously with increasing of rpm. Although the Goblin can fly at high rpm, for safety reasons we suggest to not exceed 2200rpm.
- *Fit the main blades and tail blades. (**Figure.1** and **Figure.2**)
- *Please make sure the main blades are tight on the blade grips, you should be able to violently jerk the head in both directions and the blades should not fold. Failure to tighten the blades properly can result in a boom strike. To fold the blades for storage, it is advisable to loosen them.
- *Check the collective and cyclic pitch. For 3D flight, set about +/-13°.
- *It is important to check the correct tracking of the main blades.
On the Goblin, in order to correct the tracking, adjust the main link rod. This is provided with a right/left thread system that allows continuous fine adjustments of the length of the control rod; for this adjustment it is not necessary to detach the ball link.
- *Confirm the canopy is secure prior to each flight.
- *Make sure that the battery locking pin is back in its resting position, blocking in correct way the battery tray.
- *Perform the first flight at a low headspeed, 1800 RPM. ⚠
After this first flight, do a general check of the helicopter. Verify that all screws are correctly tightened.

IN FLIGHT ABOUT HEAD

The HPS head allows for a very broad range of dampening setups. The dampers are composed of 3 O-ring (that defines the rigidity) and a technopolymer damper (that defines the maximum possible movement of the spindle). Using different Oring and dampers you can get different responses of the model.

Oring

- 80 Shore: Soft for smooth response
- 90 Shore: Firm for direct and precise response
- A = Max movement of the spindle, feeling more elastic.
- B = Medium.
- C = Min movement of the spindle, feeling more direct.

In the kit, there is the damper H1046-B with 90 Shore O-ring [other Setting >>p/n H1135-S, HC530-S].

ABOUT THE TAIL

The standard SETUP is optimized for 3d flight, headspeed 2200 rpm. If you prefer flying at low speed (< 2000 rpm), for best results we recommend changing the tail pulley to increase tail rotor rpm. In this way, you will have extremely precise tail control even at low RPM. This pulley is available in the upgrade list [H1098-26-S]
If you want to fly under 1800 rpm, we suggest to use bigger 115 mm tail blades.

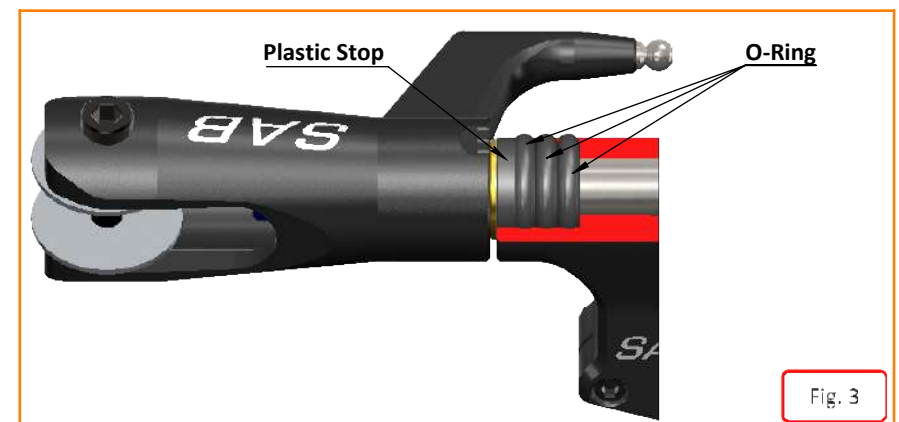
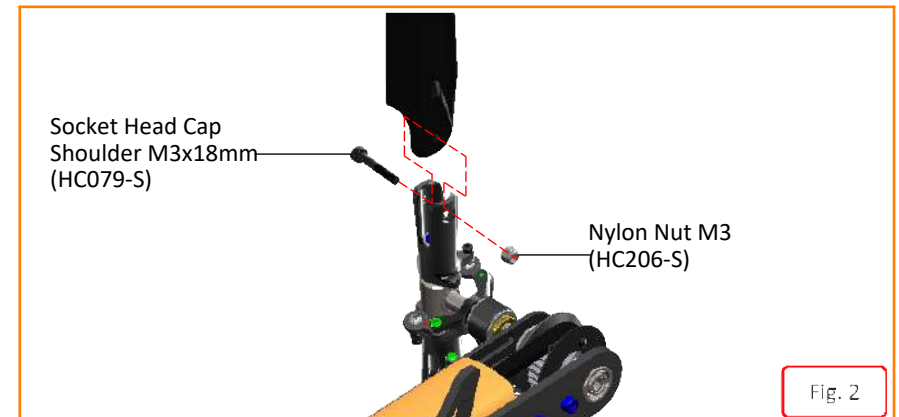
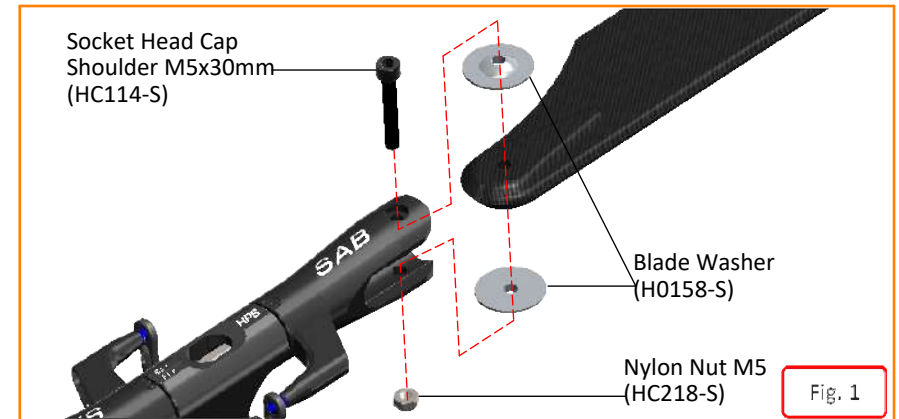

MAINTENANCE

Take a look at the red parts.

Check them frequently. All other parts are not particularly subject to wear.

The lifespan of these components varies according to the type of flying.

On average it is recommended to check these parts every 20 flights. In some instances, based on wear, these parts should be replaced every 100 flights.

Periodically lubricate the tail slider movement and its linkages as well as the swash plate movement and its linkages.

To ensure safety you should do a general inspection of the helicopter after each flight. You should check:

- Proper belt tension (motor belt and tail belt).
- Proper isolation of the wires from the carbon and aluminum parts.
- All screws and bolts remain tight.

 **IMPORTANT:** It is recommended to replace the 3 nylon screws after any crash, even if soft crash.

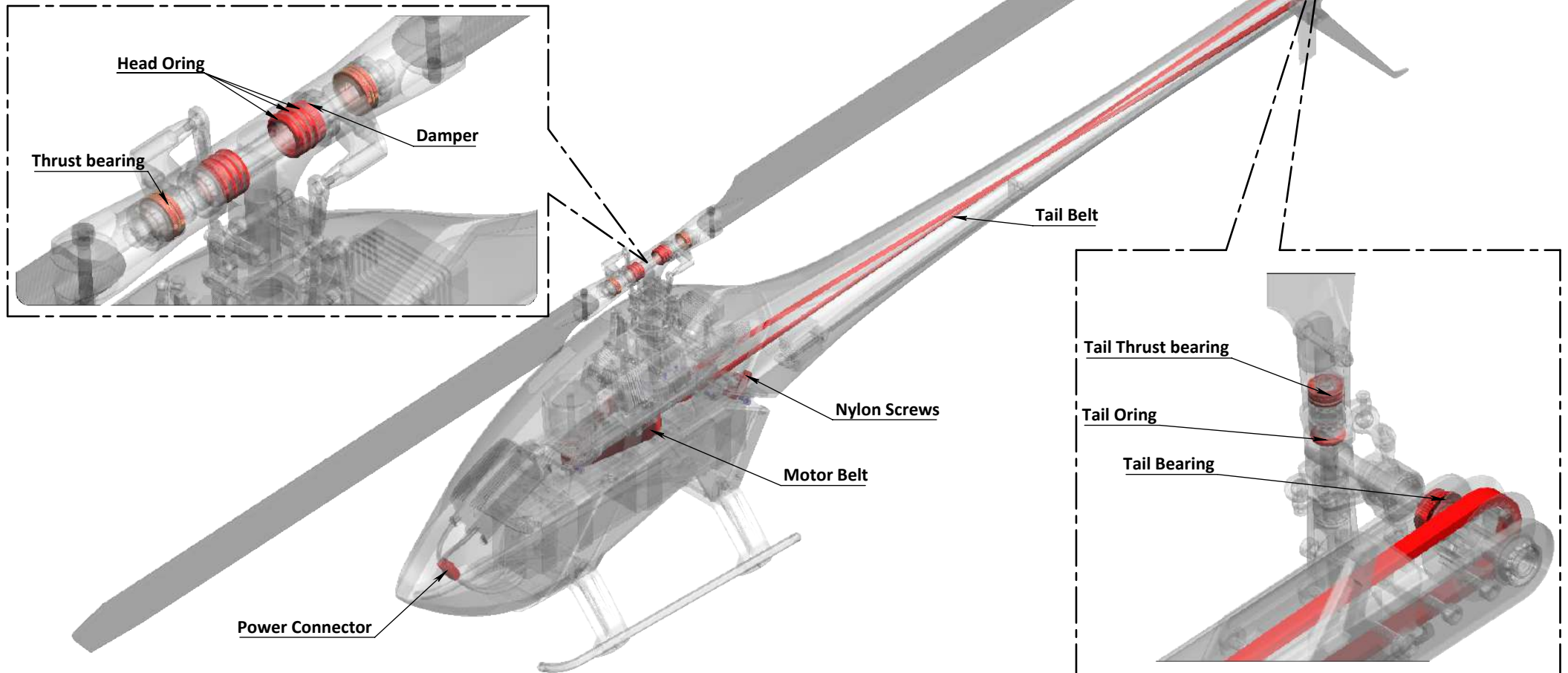

TRANSMISSION MODULE

The transmission module is supplied assembled and verified, ready to be used.

Explode and Spare Parts



NOTE:
Before to open the transmission module, use heat to neutralize the loctite. (example use a gas torch)

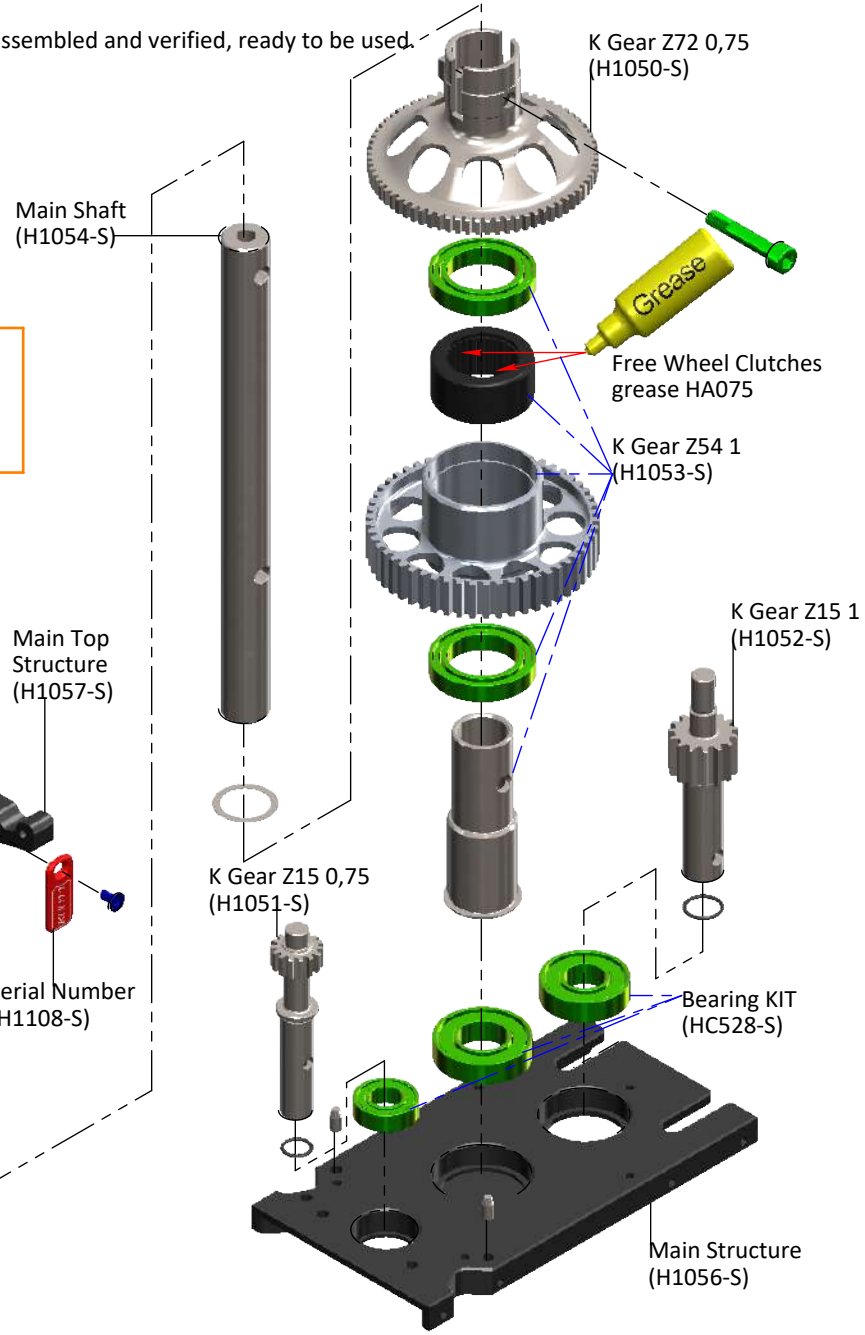
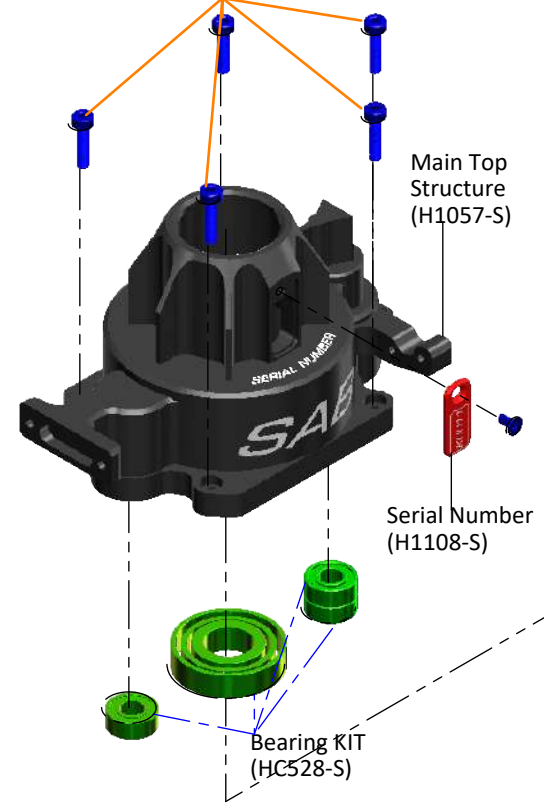

MAIN SHAFT REPLACEMENT

For replacing the main shaft:

- *Remove the serial number plate
- *Remove the M4x21 screw
- *Remove and replace the main shaft
- *Screw in the M4x21 screw, with high force and using green loctite

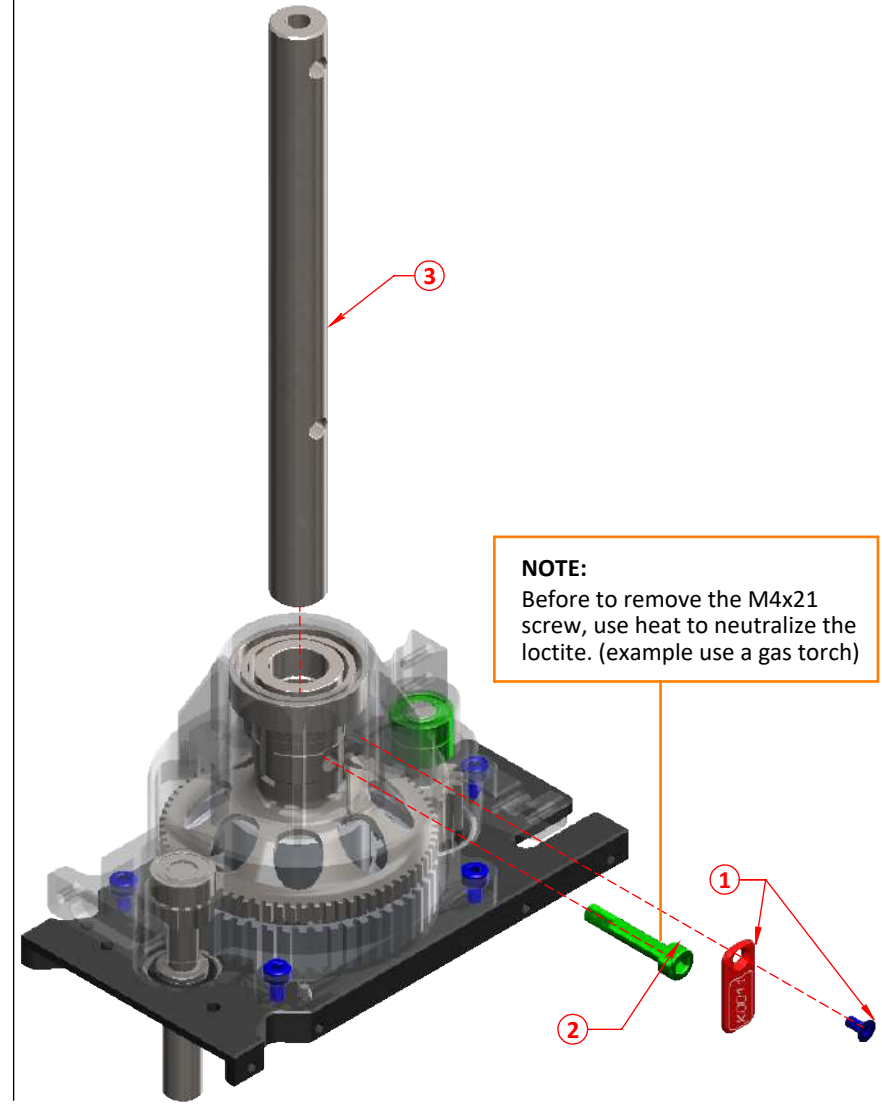

NOTE:
Before to remove the M4x21 screw, use heat to neutralize the loctite. (example use a gas torch)

1 Check the dampening on the main and tail rotor to be the same as always.

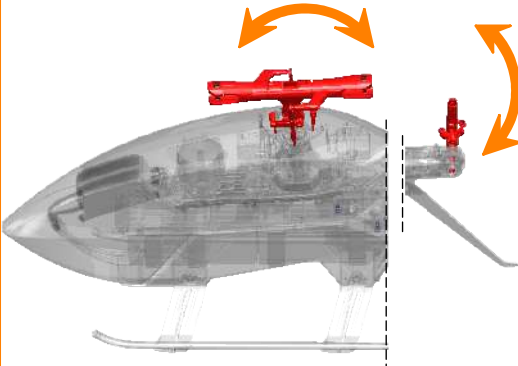

2 Tighten the main blades before flight.

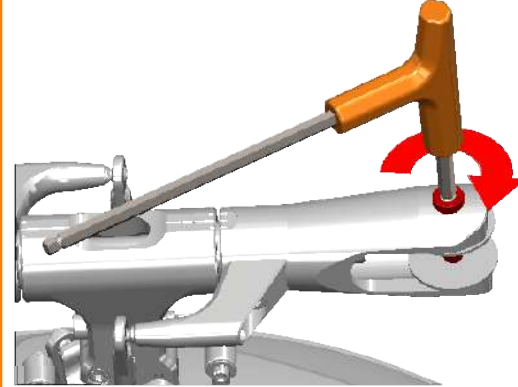

3 Check main hub screws (M4x24 and 2 M3x12) Ensure they are tight.

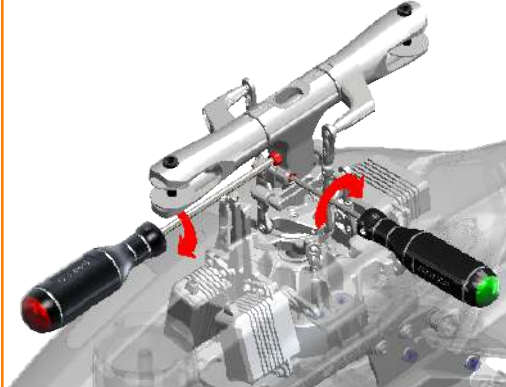

4 Check all power connectors (Good mechanical connection).

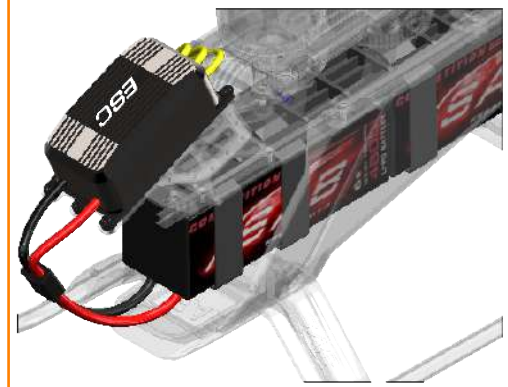

5 Check Tail & Motor belt tension. The tension has to be tight.

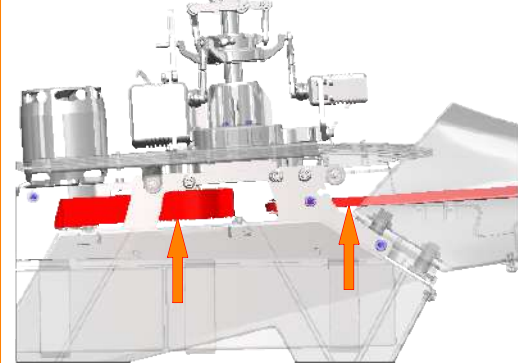

6 Check the 4 M3x12 Tail group screws. Ensure they are tight.

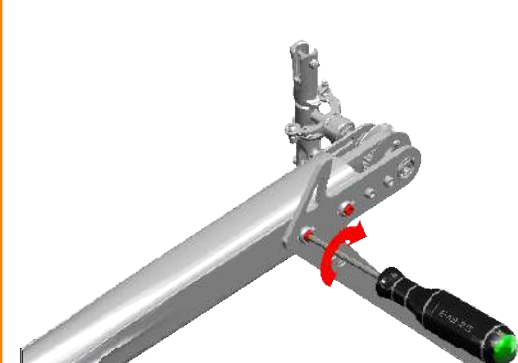

7 Check the Main Linkages & Servo Linkages

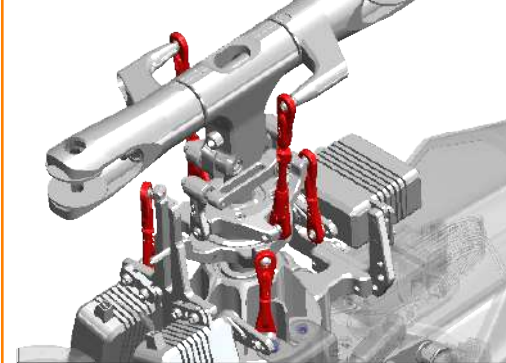

8 Check tail pulley set screws: Ensure they are tight. (It is suggested use a bit of Green Loctite.)



9 Check for vertical play of the main shaft.

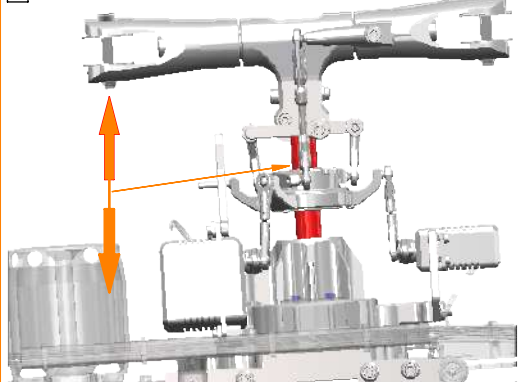

10 Check if the FBL-RX connectors are OK (hot glue is recommended).

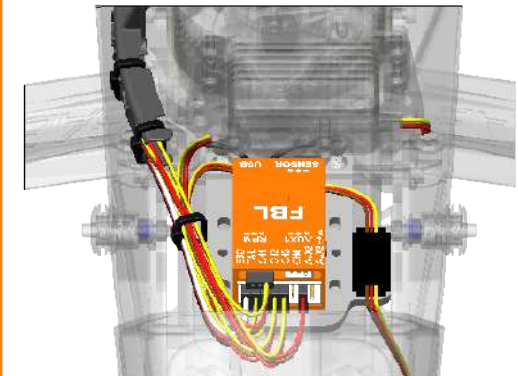

11 Check the M3x22 bell crank: Belt crank movement must be smooth and the screw locked. (It is suggested use a bit of Green Loctite.)

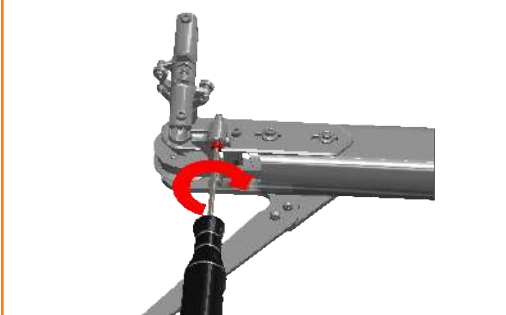











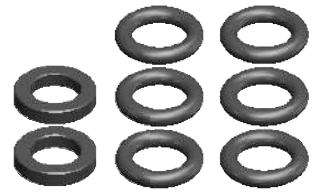

12 Be sure the follow parts are properly lubricated

- *Main shaft/swashplate
- *Tail slider/tail shaft
- *Carbon rod/carbon rod support
- *All thrust bearings
- *All plastic balls connections

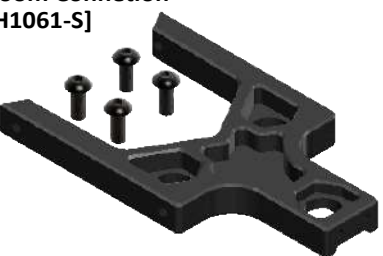

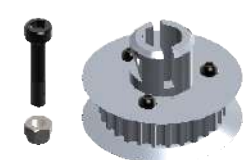
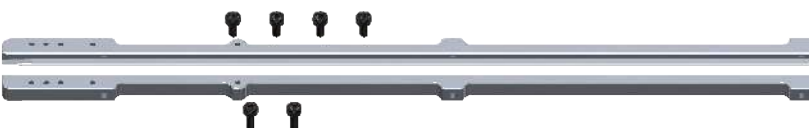
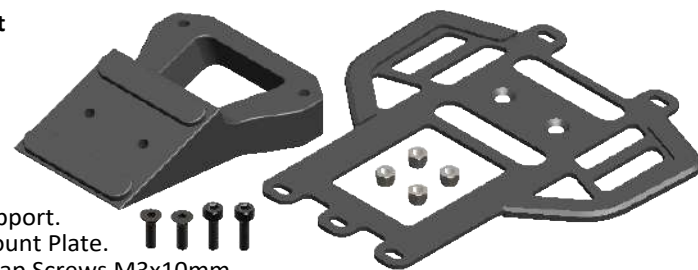
<p>Finishing Washer M3 [H0007-S]</p> <p>- 10 x Finishing Washers M3.</p>	<p>Tail Servo Lock [H0040-S]</p> <p>- 2 x Tail Servo Locks. - 2 x Servo Spacers. - 4 x Head Cap Screws M2.5x12mm.</p>	<p>Locking Element Tail [H0041-S]</p> <p>- 2 x Locking Element Tails. - 4 x Metric Hex Nylon Nuts M3. - 2 x Double Sided Tapes.</p>	<p>Linkage Tail Support [H0045-S]</p> <p>- 1 x Linkage Tail Support. - 2 x Head Cap Screws M2.5x6mm.</p>	<p>Uniball M2 5H6 [H0064-S]</p> <p>- 5 x Uniballs M2 5H6. - 5 x Uniball Spacers. - 5 x Head Cap Screws M2x8mm. - 5 x Head Cap Screws M2x6mm.</p>
<p>Uniball M3x4 5H3 [H0065-S]</p> <p>- 5 x Uniballs M3x4 5H3.5.</p>	<p>Plastic Ball Link [H0066-S]</p> <p>- 10 x Plastic Ball Link.</p>	<p>Servo Spacer [H0075-S]</p> <p>- 10 x Servo Spacers.</p>	<p>Spindle [H0079-S]</p> <p>- 1 x Spindle Shaft. - 2 x Button Cap Screw M6x10mm. - 2 x Washer $\varnothing 6 \times \varnothing 14 \times 1.5$mm</p>	<p>Bearing Support [H0143-S]</p> <p>- 1 x Bearing Support. - 1 x Flanged Bearing $\varnothing 6 \times \varnothing 13 \times 5$mm. - 2 x Head Cap Screws M3x8mm.</p>
<p>Radius Arm [H0132BM-S]</p> <p>- 2 x Radius Arms. - 2 x Spacer Arm $\varnothing 3 \times \varnothing 5 \times 2.7$mm. - 2 x Spacer Arm $\varnothing 2.5 \times \varnothing 4 \times 6.3$mm. - 2 x Uniball Radius Arms. - 2 x Head Cap Screws M3x16mm. - 2 x Head Cap Screws M2.5x18mm. - 2 x Washers 3x 4x0.5mm. - 2 x Flanged Bearings $\varnothing 2.5 \times \varnothing 6 \times 2.5$mm. - 2 x Flanged Bearings $\varnothing 3 \times \varnothing 7 \times 3$mm.</p>		<p>Aluminum Blade Spacer [H0158-S]</p> <p>- 4 x Aluminum Blade Spacer.</p>	<p>Motor Pulley [H0175-18 to 25-S]</p> <p>- 1 x Motor Pulley 18 to 25T. - 1 x Set Screws M4x4mm. - 1 x Set Screws M4x6mm. - 1 x Bushing.</p>	<p>Uniball Radius Arm [H0205-S]</p> <p>- 2 x Uniball Radius Arm.</p>
<p>Plastic Tail Linkage [H0261-S]</p> <p>- 2 x Plastic Tail Linkage. - 2 x Grip Link Bushing. - 2 x Head Cap Screws M2x6mm.</p>	<p>Tail Spindle [H0329-S]</p> <p>- 1 x Tail Spindle. - 2 x Button Cap Screws M4x6mm.</p>	<p>Tail Spacer [H0330-S]</p> <p>- 1 x Tail Oring Damper. - 2 x Washer $\varnothing 5 \times \varnothing 8.9 \times 0.75$mm. - 2 x Washer $\varnothing 7.5 \times \varnothing 10 \times 0.5$mm.</p>	<p>Plastic Ball Link [H0402-S]</p> <p>- 5 x Plastic Ball Link.</p>	<p>Main Linkage [H0417-S]</p> <p>- 2 x Main Linkage. - 4 x Plastic Ball Link.</p>

<p>Tail Blade Grips [H1033-S]</p>  <ul style="list-style-type: none"> - 2 x Aluminum Tail Blade Grip. - 4 x Bearing $\varnothing 5 \times \varnothing 10 \times 4 \text{mm}$. - 2 x Thrust bearing $\varnothing 5 \times \varnothing 10 \times 4 \text{mm}$. - 2 x Button Head Cap M4x8mm. - 2 x Socket Head Cap M2x6mm. - 2 x Washer $\varnothing 5 \times \varnothing 8.9 \times 0.75 \text{mm}$. - 2 x Washer $\varnothing 7.5 \times \varnothing 10 \times 0.5 \text{mm}$. 	<p>Center Hub [H1043-S]</p>  <ul style="list-style-type: none"> - 1 x Center Hub. - 2 x Socket Head Cap M4x24mm. - 2 x Socket Head Cap M3x12mm. - 1 x Nylon Nut M4. 	<p>Main Blade Grips [H1044-S]</p>  <ul style="list-style-type: none"> - 1 x Blade Grip. - 1 x Thrust Bearing $\varnothing 10 \times \varnothing 18 \times 5.5 \text{mm}$. - 2 x Bearing $\varnothing 10 \times \varnothing 19 \times 5 \text{mm}$. - 1 x Washer $\varnothing 10 \times \varnothing 16 \times 1 \text{mm}$. - 1 x Socket Head Cap Screw M4x10mm. 	<p>Blade Grip Arm 30 [H1045-S]</p>  <ul style="list-style-type: none"> - 2 x Blade Grip Arm. - 2 x Head Cap Screw M4x10mm. - 2 x Uniball M3x4 $\varnothing 5 \text{H3.5}$. 	<p>Damper [H1046-S]</p>  <ul style="list-style-type: none"> - 2 x Damper B. - 6 x Oring 90 Shore.
<p>Swashplate [H1047-S]</p>  <ul style="list-style-type: none"> - 1 x Swashplate Assembly. - 7 x Uniball M3. - 1 x Reference Pin. 	<p>Reference Pin [H1048-S]</p>  <ul style="list-style-type: none"> - 1 x Reference Pin. 	<p>Motor Mount [H1058-S]</p>  <ul style="list-style-type: none"> - 1 x Motor Mount. - 2 x Set Screws M5x15mm. - 2 x Washers $\varnothing 5.3 \times \varnothing 15 \times 1 \text{mm}$. - 2 x Nylon Nuts M5H4.8. - 2 x Finishing Washers M3. - 2 x Head Cap Screws M3x10mm. 	<p>Rear Servo Mount [H1059-S]</p>  <ul style="list-style-type: none"> - 1 x Rear Servo Mount. - 2 x Finishing Washer M3. - 2 x Head Cap Screws M3x8mm. 	
<p>Boom Connexion [H1061-S]</p>  <ul style="list-style-type: none"> - 1 x Boom Connexion. - 4 x Button Cap Screws M4x10mm. 	<p>Main Front Pulley [H1062-S]</p>  <ul style="list-style-type: none"> - 1 x Main Front Pulley. - 1 x Head Cap Screws M4x20mm. 	<p>Front Tail Pulley 27T [H1063-S]</p>  <ul style="list-style-type: none"> - 1 x Front Tail Pulley 27T. - 1 x Head Shoulder M3x16mm. - 1 x Nylon Nut M3. 	<p>Battery Tray Guide [H1067-S]</p>  <ul style="list-style-type: none"> - 2 x Battery Tray Guide. - 4 x Head Cap Screws M3x6mm. - 2 x Head Cap Screws M3x10mm. 	
<p>ESC Support [H1068-S]</p>  <ul style="list-style-type: none"> - 1 x ESC Support. - 1 x ESC Mount Plate. - 2 x Head Cap Screws M3x10mm. - 2 x Flat Cap Screws M3x10mm. - 4 x Nylon Nut M3. 	<p>Low Side Frame Mount [H1069-S]</p>  <ul style="list-style-type: none"> - 2 x Low Side Frame Mount. - 2 x Head Cap Screws M3x10mm. 	<p>Plastic Landing Gear Support [H1070-S]</p>  <ul style="list-style-type: none"> - 1 x Plastic Landing Gear Support. - 2 x Set Screws M4x4mm. - 2 x Nylon Nut M3. 		

Landing Gear Rod [H1071-S]



- 2 x Landing Gear Rod.
- 4 x Plug.

Canopy Front Block [H1073-S]



- 1 x Canopy Front Block.
- 4 x Nylon Nut M2.5.
- 4 x Head Cap Screws M2.5x10mm.

Tail Boom Kraken [H1074-S]



- 1 x Tail Boom Kraken.
- 2 x Locking Element Tail.
- 4 x Metric Hex Nylon Nuts M3.
- 2 x Double Sided Tapes.
- 1 x Nut Block.

Canopy Kraken [H1075-S]



- 1 x Canopy Kraken.
- 2 x Canopy Grommet.

Frame Spacer [H1076-S]



- 1 x Frame Spacer.
- 2 x Head Cap Screws M3x10mm.

Low Side Frame SX [H1080-S]



- 1 x Low Side Frame SX.

Low Side Frame DX [H1081-S]



- 1 x Low Side Frame DX.

Main Frame [H1082-S]



- 1 x Main Frame.
- 2 x M4 Bushing.

Battery Carbon SET [H1085-S]



- 1 x Xross Battery.
- 1 x Carbon Pin Support.
- 1 x Head Cap M2.5x12.
- 2 x Head Cap M2.5x8.
- 5 x Flat Screws M2.5x5.
- 1 x Alu Pin.
- 1 x Brass lever.
- 2 x Washer M2.5.

Swashplate Reference [H1088-S]

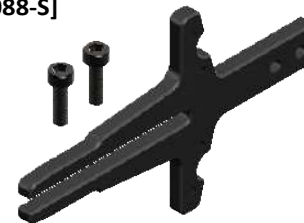

- 1 x Swashplate reference.
- 2 x Head Cap Screws M3x10mm.

Tail Shaft [H1089-S]

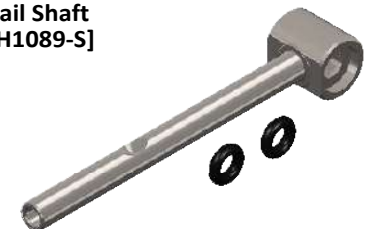

- 1 x Tail Shaft.
- 1 x Tail Hub.
- 2 x Tail Oring.

Tail Bell Crank Lever [H1090-S]



- 1 x Bell Crank Lever Assembled.
- 1 x Head Cap Screws M3x22mm.
- 1 x Head Cap Screws M2x6mm.
- 2 x Washer ϕ 3.2x ϕ 6x0.1mm.

Tail Case Spacer [H1093-S]



- 1 x Tail Case Spacer.
- 4 x Head Cap Screws M3x8mm.

Bell Crank Base [H1095-S]





































- 1 x Bell Crank Base.
- 2 x Head Cap Screws M2.5x8mm.

Carbon Fiber Side Plate [H1096-01-S]

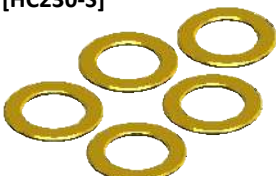

- 1 x CF Side Plate.
- 1 x Flanged Bearing ϕ 6x ϕ 13x5mm.

<p>Tail Fin [H1096-02-S]</p> <ul style="list-style-type: none"> - 1 x Tail Fin. - 2 x Flat Head Cap M3x10mm. - 2 x Metrix Hex Nylon Nut M3. - 1 x Orange Stickers. - 1 x Yellow Stickers. - 1 x White Stickers. 	<p>Tail Side Plate [H1097-S]</p> <ul style="list-style-type: none"> - 1 x Tail Side Plate. - 1 x Flanged Bearing $\phi 6x \phi 13x5mm$. 	<p>Tail Pulley 27T [H1098-S]</p> <ul style="list-style-type: none"> - 1 x Tail Pulley 27T. - 1 x Set Screws M4x6mm. 	<p>Low Side Frame Connection [H1099-S]</p> <ul style="list-style-type: none"> - 1 x Low Side Frame Connection. 			
<p>Quick Release Canopy [H1101-S]</p> <ul style="list-style-type: none"> - 2 x Quick Release Canopy. - 2 x Socket Head Cap Screw M3x6mm. 	<p>Battery Tray [H1102-S]</p> <ul style="list-style-type: none"> - 1 x Plastic Battery Tray. - 2 x Double side Tape. - 1 x Battery Protection. - 4 x Veclo Strap. 	<p>Wire Cover [H1107-S]</p> <ul style="list-style-type: none"> - 1 x Wire Cover. - 1 x Finishing Washer M3. - 1 x Head Cap Screws M3x8mm. - 2 x Button Cap Screws M2.5x6mm. 				
<p>Tail Pitch Slider [H1112-S]</p> <ul style="list-style-type: none"> - 1 x Tail Pitch Slider Assembled. - 2 x Slider Linkage. - 2 x Head Cap Screws M2x6mm. - 2 x Spacer. 	<p>Carbon Canopy Base Support [H1113-S]</p> <ul style="list-style-type: none"> - 2 x Carbon Canopy Base Support. 	<p>Tail Slider Bush [H1115-S]</p> <ul style="list-style-type: none"> - 2 x Tail Slider Bush. 	<p>FBL/RX Support [H1103-S]</p> <ul style="list-style-type: none"> - 1 x Alu Long FBL Plate. - 1 x Alu Short FBL Plate. - 1 x RX Plate. - 4 x Head Screws M2.5x8. - 2 x CF Canopy base. - 4 x Head Cap M3x8. - 2 x RX Column. 	<p>Canopy Base Support [H1179-S]</p> <ul style="list-style-type: none"> - 2 x Canopy Base Support. 		
<p>[HC004-S]</p> <ul style="list-style-type: none"> - 8 x Socket Head Cap Screws M2x6mm. 	<p>[HC008-S]</p> <ul style="list-style-type: none"> - 8 x Socket Head Cap Screws M2x8mm. 	<p>[HC018-S]</p> <ul style="list-style-type: none"> - 8 x Socket Head Cap Screws M2.5x6mm. 	<p>[HC019-S]</p> <ul style="list-style-type: none"> - 8 x Button Special Screws M2.5x6mm. 	<p>[HC020-S]</p> <ul style="list-style-type: none"> - 8 x Socket Head Cap Screws M2.5x8mm. 	<p>[HC022-S]</p> <ul style="list-style-type: none"> - 8 x Socket Head Cap Screws M2.5x10mm. 	<p>[HC032-S]</p> <ul style="list-style-type: none"> - 5 x Socket Head Cap Screws M2.5x18mm.

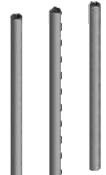
<p>[HC044-S]</p>  <p>- 8 x Socket Head Cap Screws M3x6mm.</p>	<p>[HC050-S]</p>  <p>- 8 x Socket Head Cap Screws M3x8mm.</p>	<p>[HC056-S]</p>  <p>- 8 x Socket Head Cap Screws M3x10mm.</p>	<p>[HC062-S]</p>  <p>- 8 x Socket Head Cap Screws M3x12mm.</p>	<p>[HC068-S]</p>  <p>- 8 x Socket Head Cap Screws M3x16mm.</p>	<p>[HC074-S]</p>  <p>- 2 x Socket Head Cap Shoulder Screws M3x16. - 2 x Nylon Nut M3.</p>	<p>[HC079-S]</p>  <p>- 2 x Socket Head Cap Shoulder Screws M3x18. - 2 x Nylon Nut M3.</p>
<p>[HC086-S]</p>  <p>- 8 x Socket Head Cap Screws M3x22mm.</p>	<p>[HC096-S]</p>  <p>- 8 x Button Head Cap Screws M4x6mm.</p>	<p>[HC098-S]</p>  <p>- 8 x Button Head Cap Screws M4x8mm.</p>	<p>[HC100-S]</p>  <p>- 8 x Button Head Cap Screws M4x10mm.</p>	<p>[HC102-S]</p>  <p>- 8 x Socket Head Cap Screws M4x10mm.</p>	<p>[HC104-S]</p>  <p>- 8 x Socket Head Cap Screws M4x22mm.</p>	<p>[HC111-S]</p>  <p>- 8 x Socket Head Cap Shoulder Screws M4x24.</p>
<p>[HC114-S]</p>  <p>- 2 x Socket Head Cap Shoulder Screws M5x30. - 2 x Nylon Nut M5.</p>	<p>[HC124-S]</p>  <p>- 8 x Socket Head Cap Screws M6x10mm.</p>	<p>[HC125-S]</p>  <p>- 8 x Flat Head Cap Screws M2.5x8mm.</p>	<p>[HC128-S]</p>  <p>- 8 x Flat Head Cap Screws M2.5x5mm.</p>	<p>[HC132-S]</p>  <p>- 8 x Flat Head Cap Screws M3x5mm.</p>	<p>[HC135-S]</p>  <p>- 8 x Flat Head Cap Screws M3x10mm.</p>	<p>[HC136-S]</p>  <p>- 8 x Self Tapping Cap Screws M3x10mm.</p>
<p>[HC140-S]</p>  <p>- 8 x Set Screws M2.5x18.</p>	<p>[HC152-S]</p>  <p>- 8 x Set Screws M4x4mm.</p>	<p>[HC153-S]</p>  <p>- 8 x Set Screws M4x6mm.</p>	<p>[HC176-S]</p>  <p>- 5 x Washer $\varnothing 3 \times \varnothing 4 \times 0.5 \text{mm}$.</p>	<p>[HC180-S]</p>  <p>- 5 x Washer $\varnothing 3.2 \times \varnothing 6 \times 0.5 \text{mm}$.</p>	<p>[HC188-S]</p>  <p>- 5 x Washer $\varnothing 5.3 \times \varnothing 15 \times 1 \text{mm}$.</p>	<p>[HC194-S]</p>  <p>- 5 x Washer $\varnothing 6 \times \varnothing 14 \times 1.5 \text{mm}$.</p>
<p>[HC200-S]</p>  <p>- 8 x Metrix Nylon Nut M2.5.</p>	<p>[HC206-S]</p>  <p>- 8 x Metrix Nylon Nut M3.</p>	<p>[HC212-S]</p>  <p>- 8 x Metrix Nylon Nut M4.</p>	<p>[HC218-S]</p>  <p>- 8 x Metrix Nylon Nut M5.</p>	<p>[HC230-S]</p>  <p>- 5 x Washer $\varnothing 10 \times \varnothing 16 \times 1 \text{mm}$.</p>	<p>[HC232-S]</p>  <p>- 5 x Washer $\varnothing 10 \times \varnothing 16 \times 0.2 \text{mm}$.</p>	<p>[HC242-S]</p>  <p>- 3 x Thread Rod M2.5x40.</p>

<p>[HC324-S]</p>  <p>- 1 x Tail Belt 1926mm.</p>	<p>[HC335-S]</p>  <p>- 4 x Tail Oring.</p>	<p>[HC400-S]</p>  <p>- 4 x Flanged Bearing $\varnothing 2.5x \varnothing 6x2.6mm$.</p>	<p>[HC402-S]</p>  <p>- 4 x Flanged Bearing $\varnothing 3x \varnothing 7x3mm$.</p>	<p>[HC410-S]</p>  <p>- 4 x Flanged Bearing $\varnothing 5x \varnothing 9x3mm$.</p>	<p>[HC411-S]</p>  <p>- 4 x Ball Bearing $\varnothing 5x \varnothing 10x4mm$.</p>	<p>[HC414-S]</p>  <p>- 2 x Flanged Bearing $\varnothing 6x \varnothing 13x5mm$.</p>
<p>[HC418-S]</p>  <p>- 2 x Flanged Bearing $\varnothing 8x \varnothing 12x3.5mm$.</p>	<p>[HC422-S]</p>  <p>- 4 x Ball Bearing $\varnothing 10x \varnothing 19x5mm$.</p>	<p>[HC426-S]</p>  <p>- 2 x Ball Bearing $\varnothing 12x \varnothing 24x6mm$.</p>	<p>[HC430-S]</p>  <p>- 2 x Rad Bearing $\varnothing 30x \varnothing 37x4mm$.</p>	<p>[HC435-S]</p>  <p>- 2 x Thrust Bearing $\varnothing 5x \varnothing 10x4mm$.</p>	<p>[HC438-S]</p>  <p>- 2 x Thrust Bearing $\varnothing 10x \varnothing 18x5.5mm$.</p>	<p>[HC528-S]</p>  <p>- 1 x Transmission Bearing SET.</p>
<p>[HC529-S]</p>  <p>- 6 x O-ring 90 shore.</p>	<p>[HC530-S]</p>  <p>- 6 x O-ring 80 shore.</p>	<p>[HC532-S]</p>  <p>- 2 x Ball Bearing $\varnothing 17x \varnothing 26x5mm$.</p>	<p>[HC533-S]</p>  <p>- 1 x One Way Bearing $\varnothing 17x \varnothing 25x12mm$.</p>	<p>[HC535-S]</p>  <p>- 1 x Motor Belt GT3-282-19 mm.</p>	<p>[HC537-S]</p>  <p>- 1 x Carbon Rod $\varnothing 3x \varnothing 4x710mm$ - 2 x Plastic Ball Linkage - 2 x Thread Rod M2.5x40. - 2 x Aluminum Bush.</p>	
<p>[HC543-S]</p>  <p>- 5 x Set Screw M5x16mm.</p>	<p>[HC544-S]</p>  <p>- 8 x Head Cap Screw M4x20.</p>	<p>[HC545-S]</p>  <p>- 8 x Head Cap Screw Shoulder M4x21.5mm.</p>	<p>[HC546-S]</p>  <p>- 3 x Bolt M10x20mm. - 3 x Nut M10x5mm. - 1 x Nut Block. - 1 x Special Tool. - 2 x Washer.</p>	<p>[HC549-S]</p>  <p>- 8 x Self Socket Cap M3x12.</p>	<p>[690-TBS]</p>  <p>- 2 x Main Blades 690mm.</p>	<p>[105-TBS]</p>  <p>- 2 x Tail Blades 105mm.</p>
<p>[HA021-S]</p>  <p>- 2 x Canopy Grommet.</p>	<p>[HA035-S]</p>  <p>- 2 x Double side tape 30x100x1mm.</p>	<p>[HA041-S]</p>  <p>- 2 x Strap 20x250mm.</p>	<p>[HA050-S]/[HA051-S]</p>  <p>- 4 x Servo Horn.</p>	<p>[HA072-S]</p>  <p>- 1 x Blade Holder.</p>	<p>[HA075-S]</p>  <p>- 1 x Free Wheel Clutches grease.</p>	<p>[HA076-S]</p>  <p>- 1 x Transmissions module grease.</p>

GOBLIN



Carefully check your model before each flight to ensure it is airworthy.

Consider flying only in areas dedicated to the use of model helicopters.

Check and inspect the flying area to ensure it is clear of people and obstacles.

Rotor blades can rotate at very high speeds! Be aware of the danger they pose.

Always keep the model at a safe distance from other pilots and spectators.

Avoid maneuvers with trajectories towards a crowd.

Always maintain a safe distance from the model.

GOBLIN KRAKEN

Release 1.1 - June 2019

WORLD DISTRIBUTION

www.goblin-helicopter.com

For sales inquiries, please email:

sales@goblin-helicopter.com

For info inquiries, please email:

support@goblin-helicopter.com

Attention: If you are a customer and have questions or need of assistance, please contact in a first time the Goblin retailer where you made the purchase.

EUROPEAN DISTRIBUTION

www.sabitaly.it

For sales inquiries, please email:

sales@sabitaly.it

For info inquiries, please email:

info@sabitaly.it

Attention: If you are a customer and have questions or need of assistance, please contact in a first time the Goblin retailer where you made the purchase.

WWW.GOBLIN-HELICOPTER.COM

SAB



SAB HELI DIVISION