

Manual

LOGO 690 SX

Mikado
Model Helicopters

www.mikado-heli.de



Index

Manual Mikado LOGO 690 SX

Safety Instructions	2
Tools for Assembly & R/C Equipment	2
1 Mainframe.	3
2 Tail Rotor	4
3 Tail Boom	5
4 Main Gear & Tail Boom Assembly	6
5 V-Bar Rotor Head	7
6 Servo Installation	8
7 Mounting the Motor.	9
8 Canopy Mounting.	9
9 Radio and Battery	10
10 Overview Chassis	11
11 Overview Tail Rotor	12
12 Overview V-Bar Head	13

Max. rotorhead rpm LOGO SX 690: 2000
 Max. collective range: +/- 11°
 Max. rotor blade size: 690 mm
 Max. tail rotor blade size: 105mm
 Max. LiPo Akku size: 10S 5000 mAh
 Max. LiPo Akku size: 12S 5000 mAh

LOGO 690 SX is not recommended for novices. This helicopter is a complex system. Basic knowledge of the function of a model helicopter is required to build and operate the LOGO 690 SX.

Note: There is no bag 10. The bags are numbered 1 to 12, with the exception of 10.

Warning:
 The LOGO 690 SX is designed to be used with Scorpion motor HK 4525-370 Kv and a 15 teeth pinion exclusively. Do not use any other motors of any kind, as this can cause damage or failure of the gear train. It is absolutely essential to keep within the recommended pitch range from +/- 11°. Otherwise the one way bearing will be damaged.

Safety Instructions

OPERATING YOUR MODEL SAFELY

Operate the helicopter in spacious areas with no people nearby.

!Warning: Do NOT operate the helicopter in the following places and situations (or else you risk severe accidents):

- in places where children gather or people pass through
- in residential areas and parks
- indoors and in limited space
- in windy weather or when there is any rain, snow, fog or other precipitation

If you do not observe these instructions you may be held liable for personal injury or property damage! Always check the R/C system prior to operating your helicopter. When the R/C system batteries get weaker, the operational range of the R/C system decreases. Note that you may lose control of your model when operating it under such conditions.

Keep in mind that other people around you might also be operating a R/C model.

Never use a frequency which someone else is using at the same time. Radio signals will be mixed and you will lose control of your model.

If the model shows irregular behavior, bring the model to a halt immediately. Turn off all power switches and disconnect the batteries. Investigate the reason and

fix the problem. Do not operate the model again as long as the problem is not solved, as this may lead to further trouble and unforeseen accidents.

! Warning: In order to prevent accidents and personal injury, be sure to observe the following:

Before flying the helicopter, ensure that all screws are tightened. A single loose screw may cause a major accident.

Replace all broken or defective parts with new ones, as damaged parts lead to crashes.

Never approach a spinning rotor. Keep at least 10 meters/yards away from a spinning rotor blades.

Do not touch the motor immediately after use. It may be hot enough to cause burns.

Perform all necessary maintenance.

PRIOR TO ADJUSTING AND OPERATING YOUR MODEL, OBSERVE THE FOLLOWING

!Warning: Operate the helicopter only outdoors and out of people's reach as the main rotor operates at high rpm!

! Warning: While adjusting, stand at least 10 meters/yards away from the helicopter!

Novice R/C helicopter pilots should always seek advice from experienced pilots to obtain hints with assembly and for pre-flight adjustments. Note that a badly assembled or insufficiently adjusted helicopter is a safety hazard!

In the beginning, novice R/C helicopter pilots should always be assisted by an experienced pilot and never fly alone!

Tools for Assembly & R/C Equipment

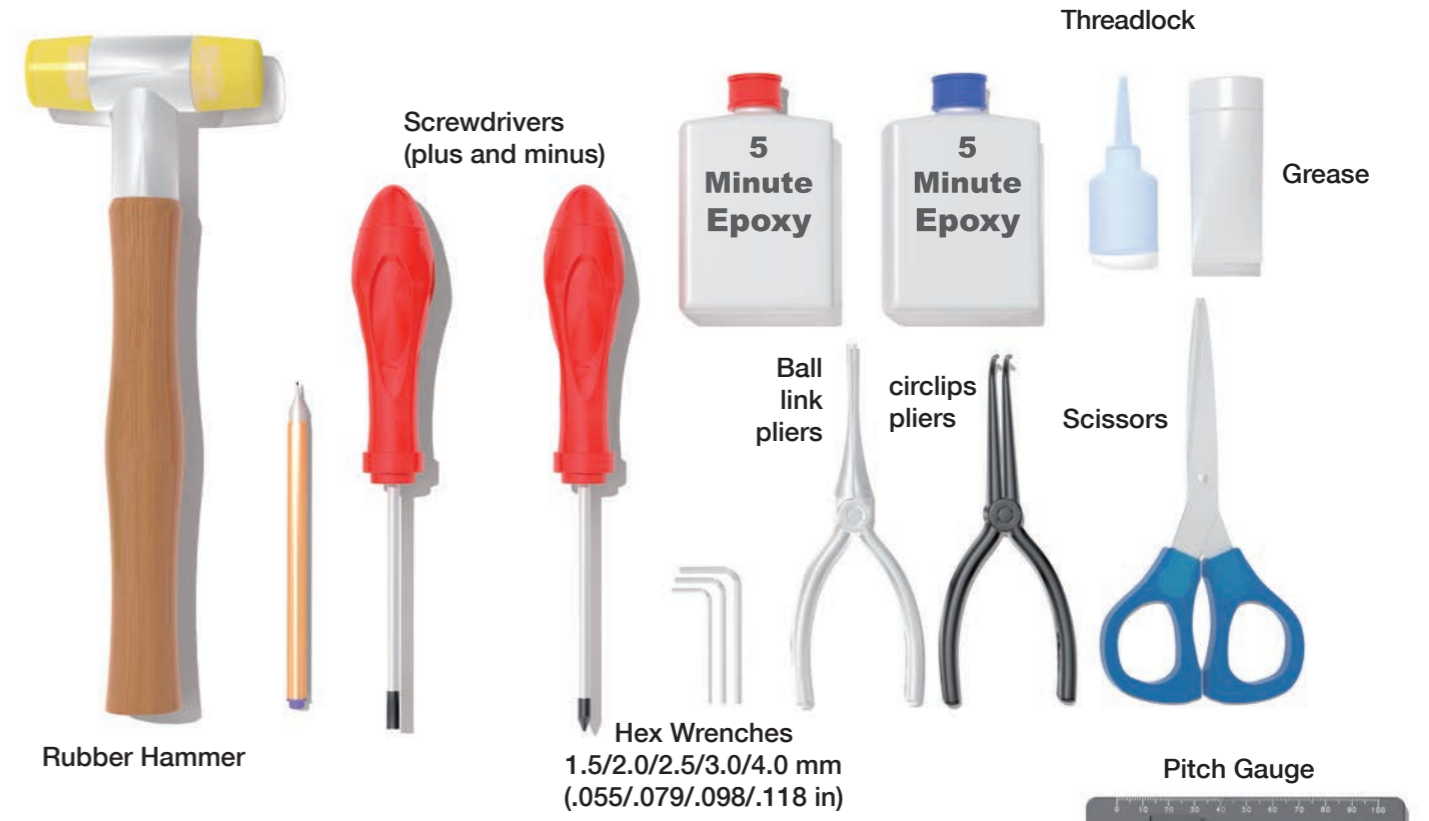

Alle shown products are examples. You may use different brands.

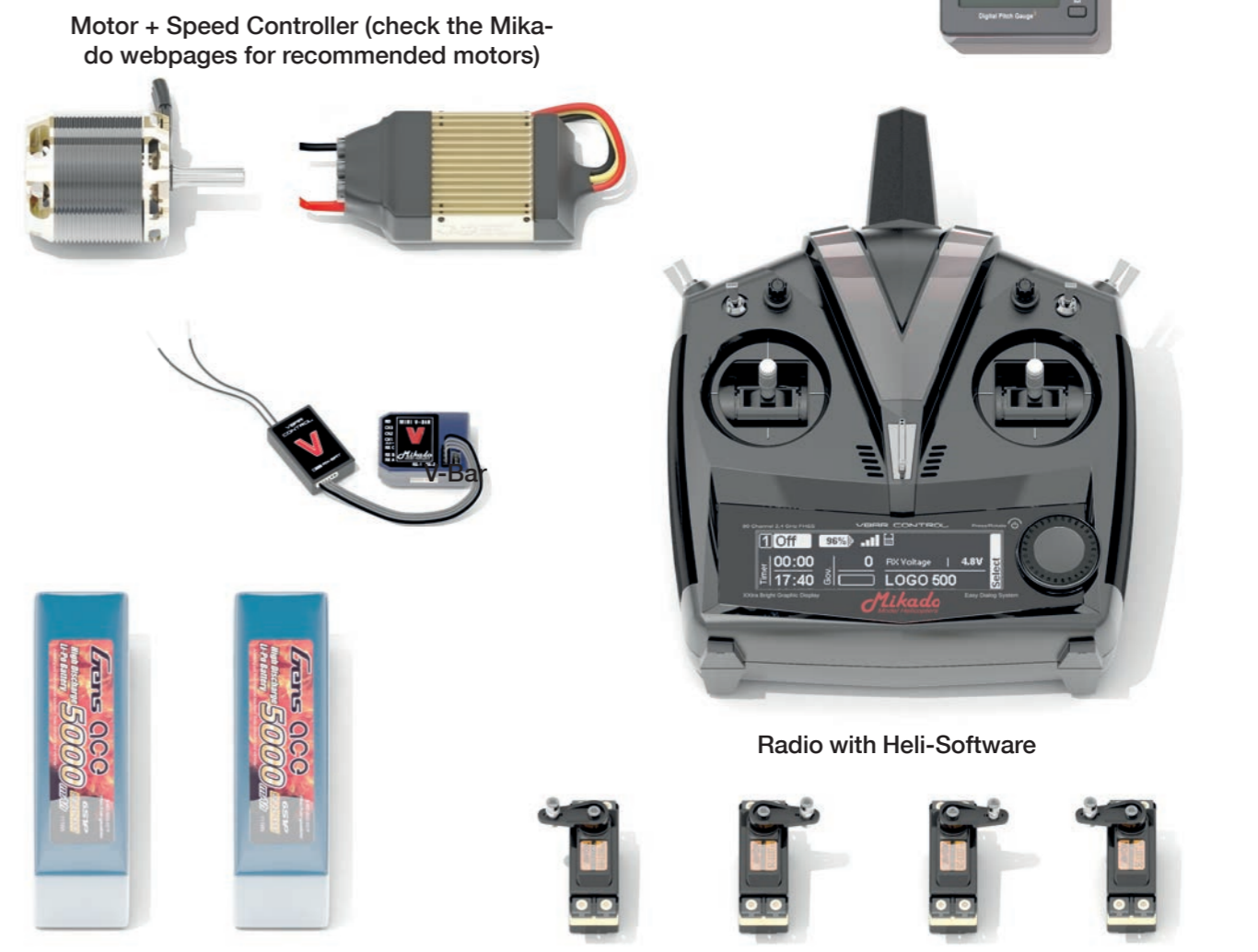

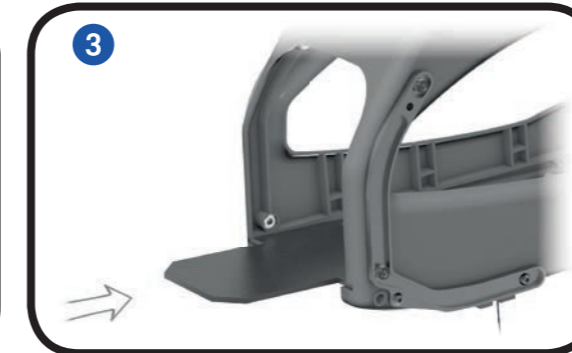
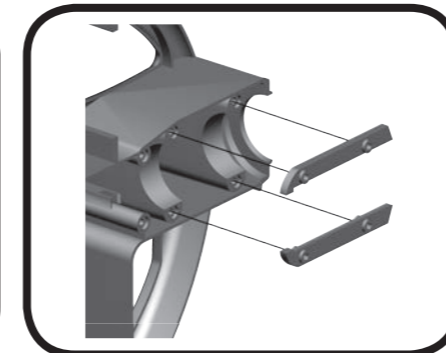
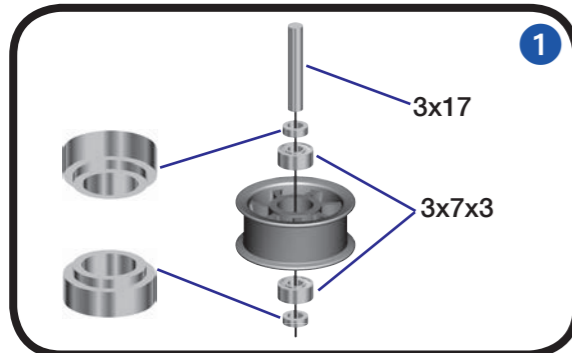

Before you combine the two sides of the main frame, attach the two belt tensioners (#4089, bag 6).

Using the rod M2.5x60 from bag 7, position all 14 nylon nuts in the right side frame.

After assembling the chassis, please move the battery plate in to the frame.

Bag 1

- 17x M2,5
- 1x SW5x59
- 3x Ø5x49
- 2x 3x17
- 4x 3x5x2,5
- 4x M3x20
- 2x M3x16
- 2x 2,2x6
- 4x M2,5x8
- 9x M2,5x10
- 4x M2,5x16
- 4x M2,5x12
- 2x M3x20
- 2x M3

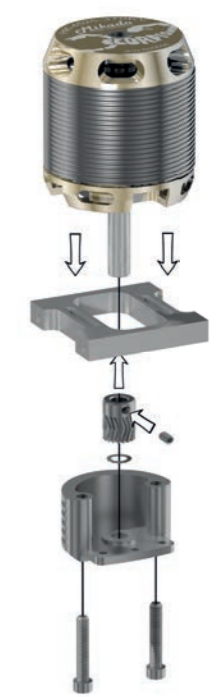
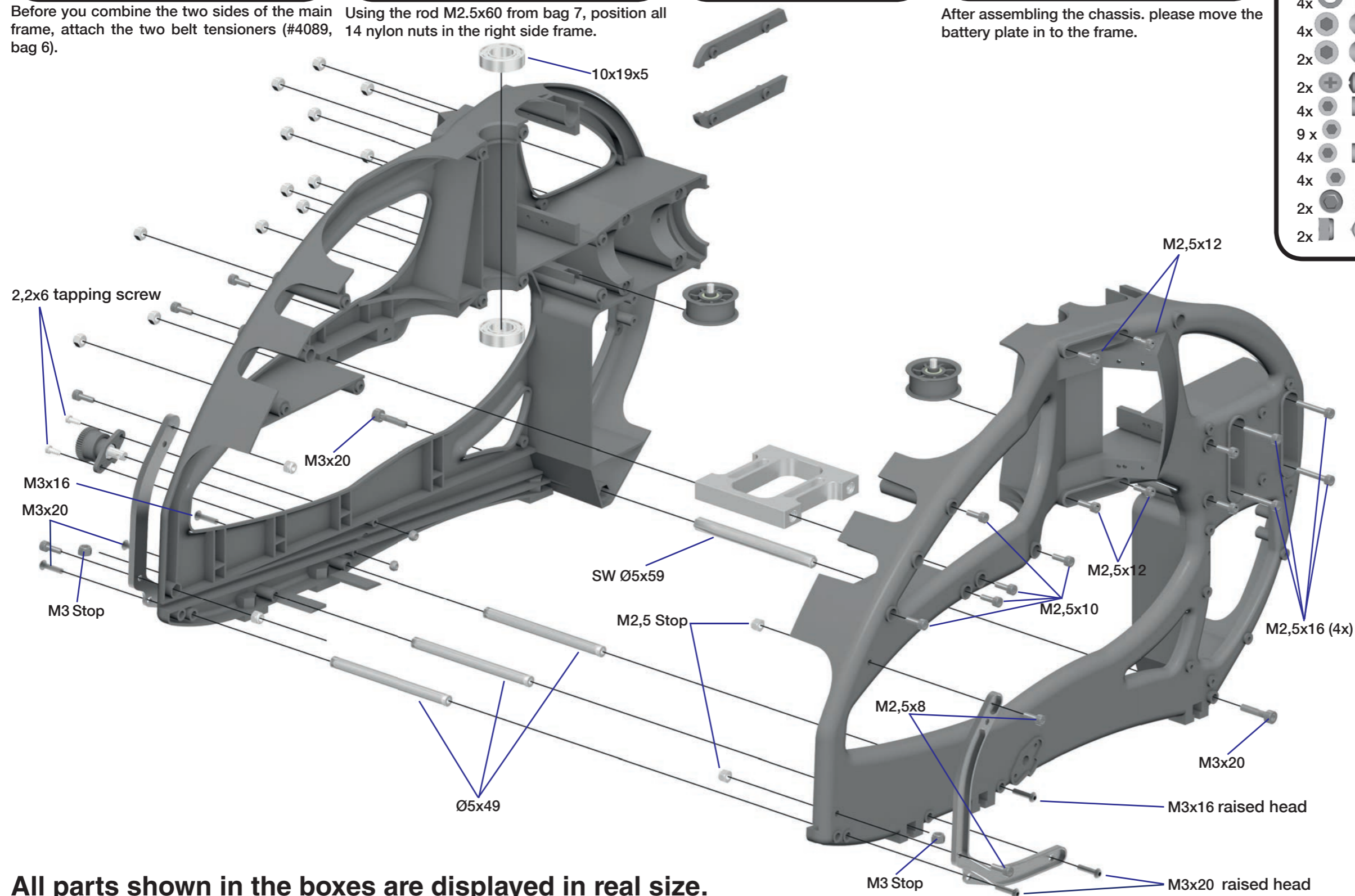

You should position the motor pinion on the motor shaft, before you mount the motor plate. You may also mount the motor pinion at a later stage, but the process will be more cumbersome. For reading on how to mount the motor pinion, please flip to page 9.

All parts shown in the boxes are displayed in real size.

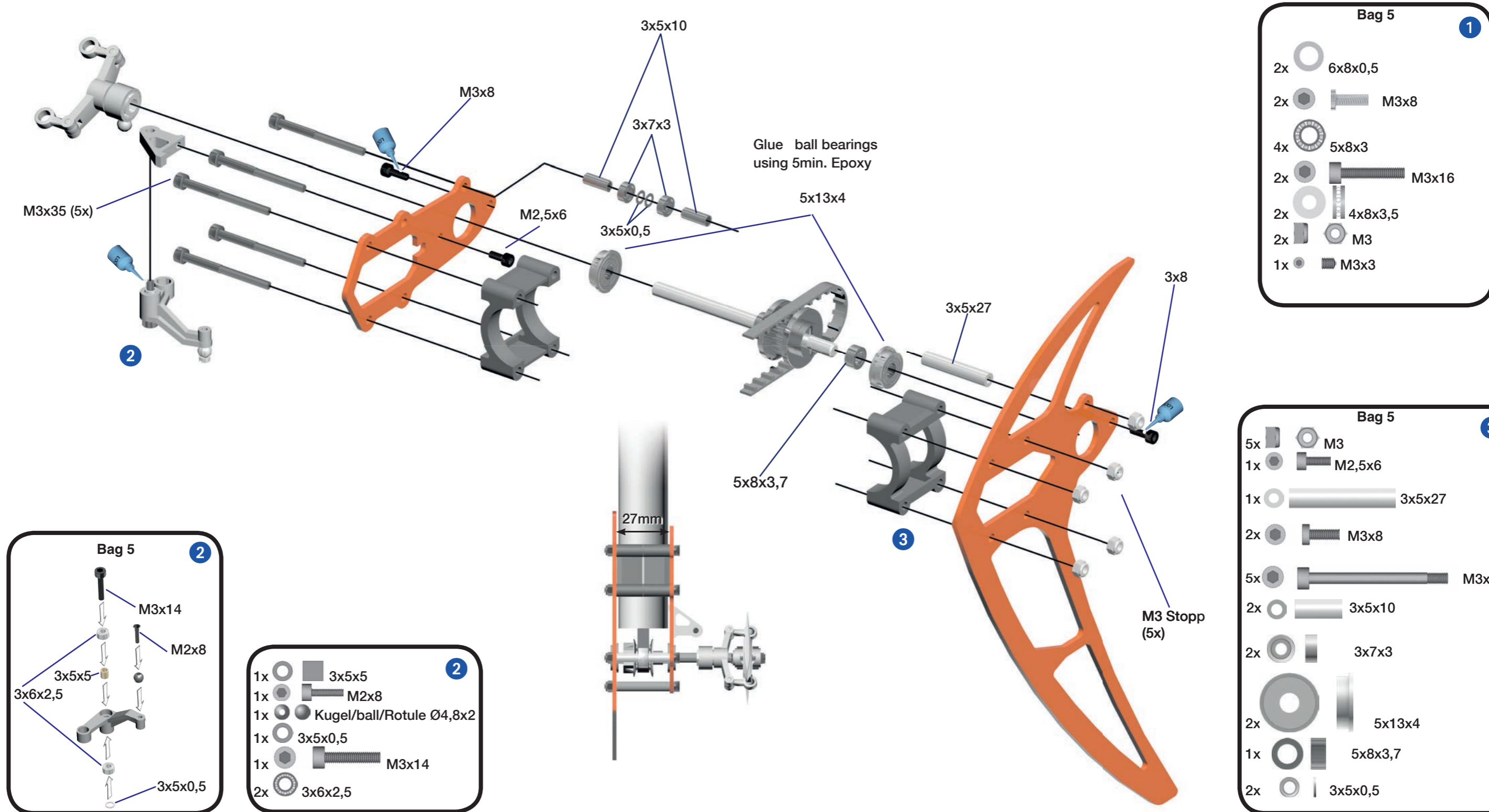
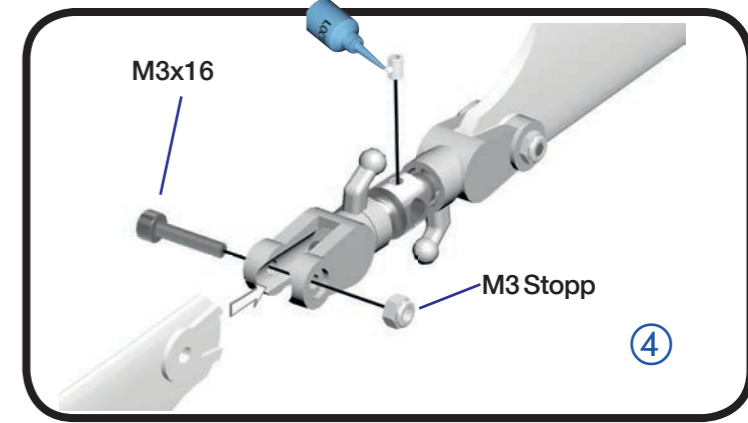
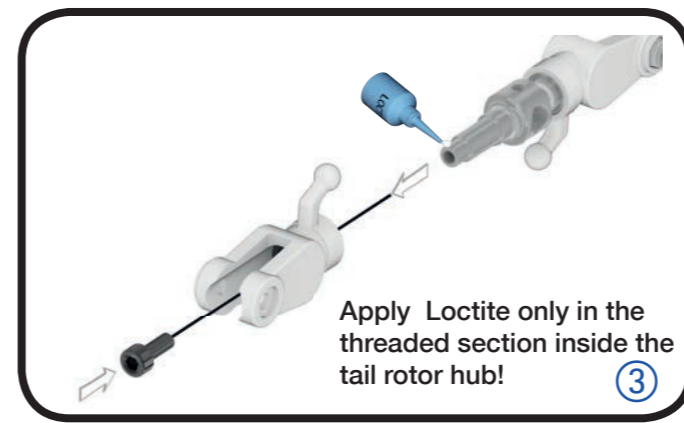
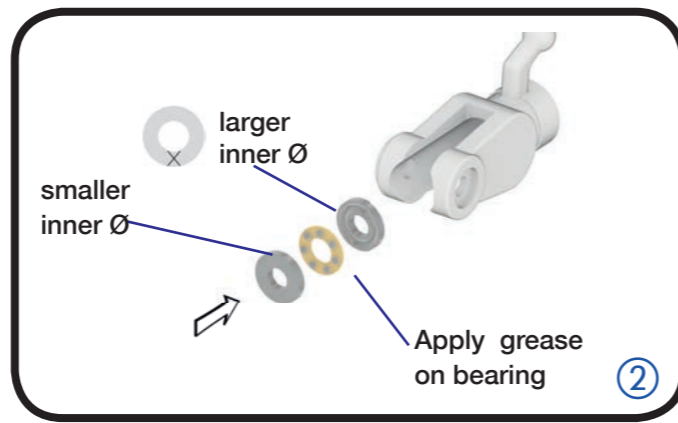
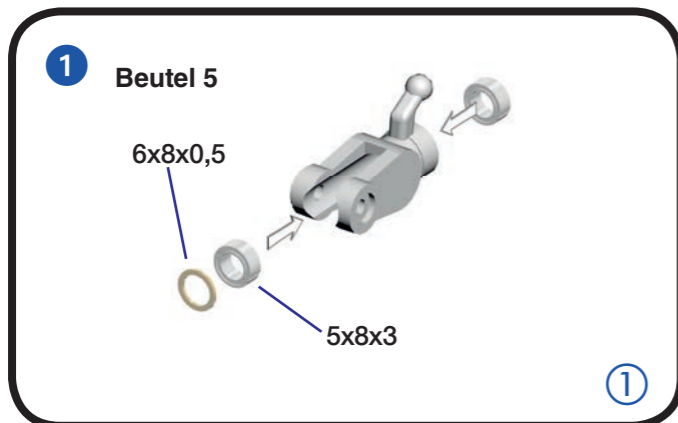

- Bag 5**
- 2x 6x8x0,5
 - 2x M3x8
 - 4x 5x8x3
 - 2x M3x16
 - 2x 4x8x3,5
 - 2x M3
 - 1x M3x3

- Bag 5**
- M3x14
 - M2x8
 - 3x5x5
 - 3x6x2,5
 - 3x5x0,5

- 2**
- 1x 3x5x5
 - 1x M2x8
 - 1x Kugel/ball/Rotule Ø4,8x2
 - 1x 3x5x0,5
 - 1x M3x14
 - 2x 3x6x2,5

- Bag 5**
- 5x M3
 - 1x M2,5x6
 - 1x 3x5x27
 - 2x M3x8
 - 5x M3x35
 - 2x 3x5x10
 - 2x 3x7x3
 - 2x 5x13x4
 - 1x 5x8x3,7
 - 2x 3x5x0,5

- Bag 6**
- 2x M3
 - 1x M2x6
 - 1x M2 Stop
 - 2x M3x16
 - 4x Kugel/ball/Rotule Ø6x3
 - 2x M3x40
 - 2x 3mm
 - 2x

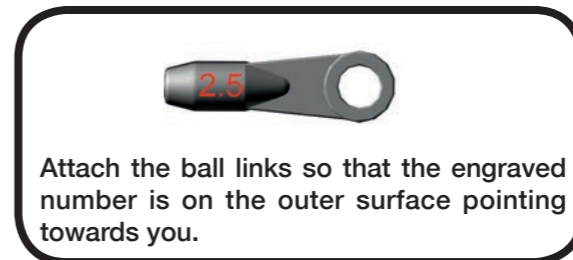
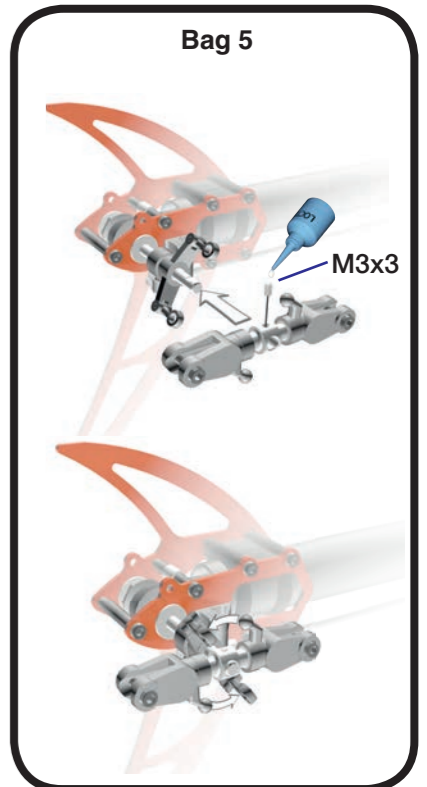
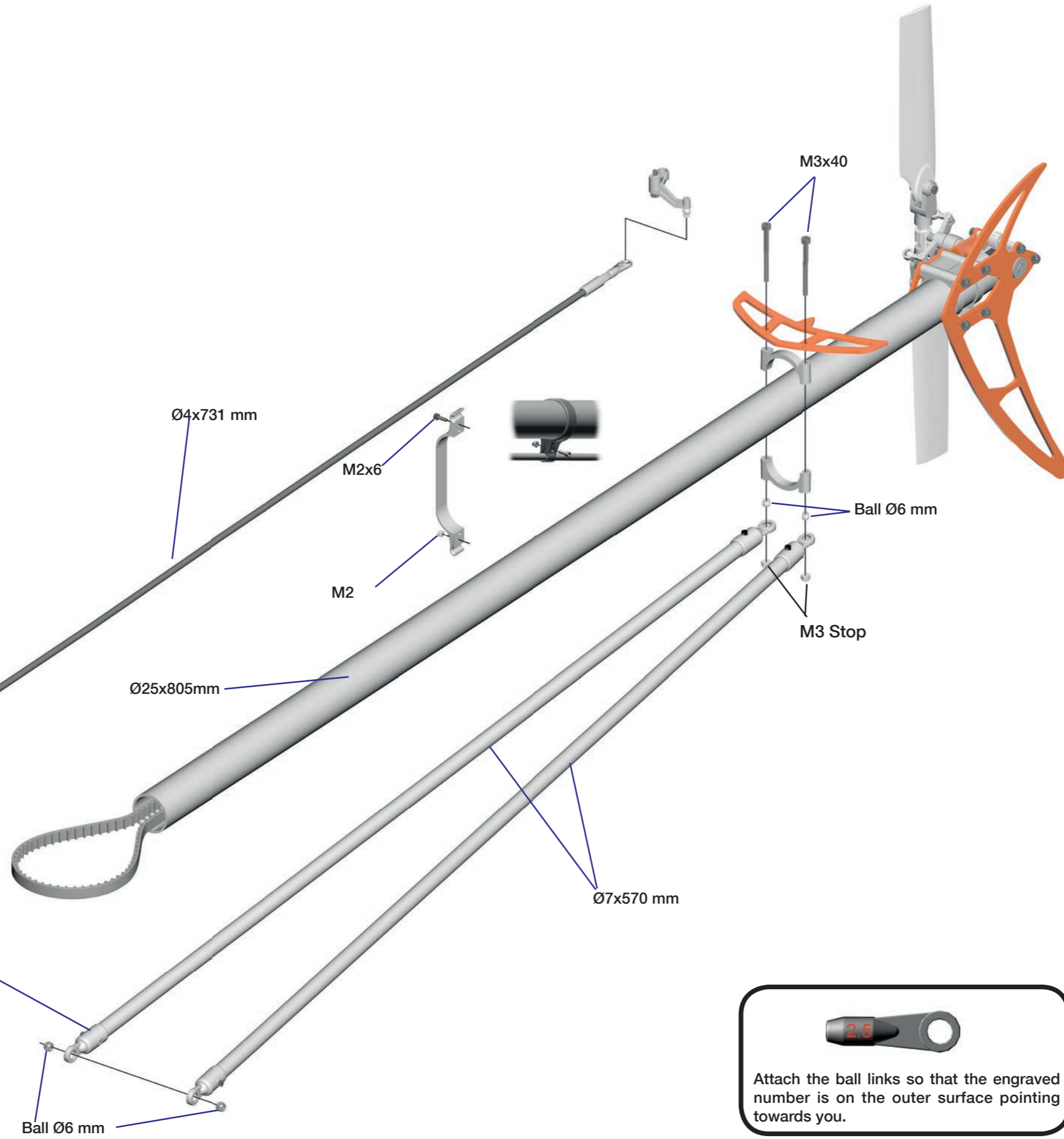
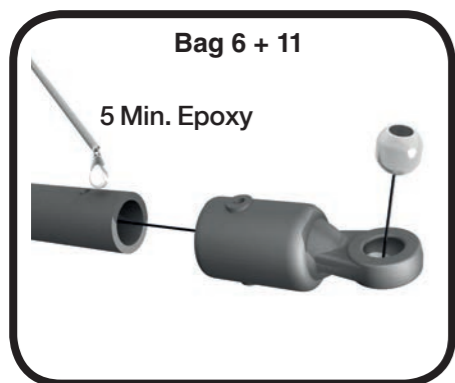
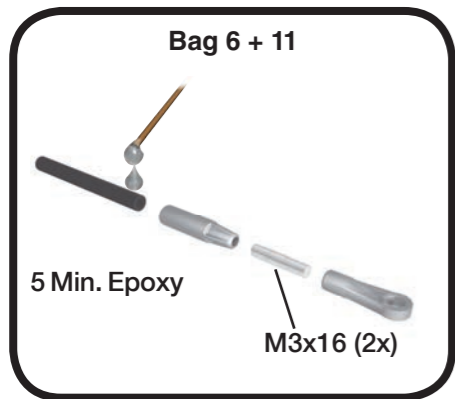

4 Main Gear & Tail Boom Assembly

Bag 2 • Bag 3 • Bag 8

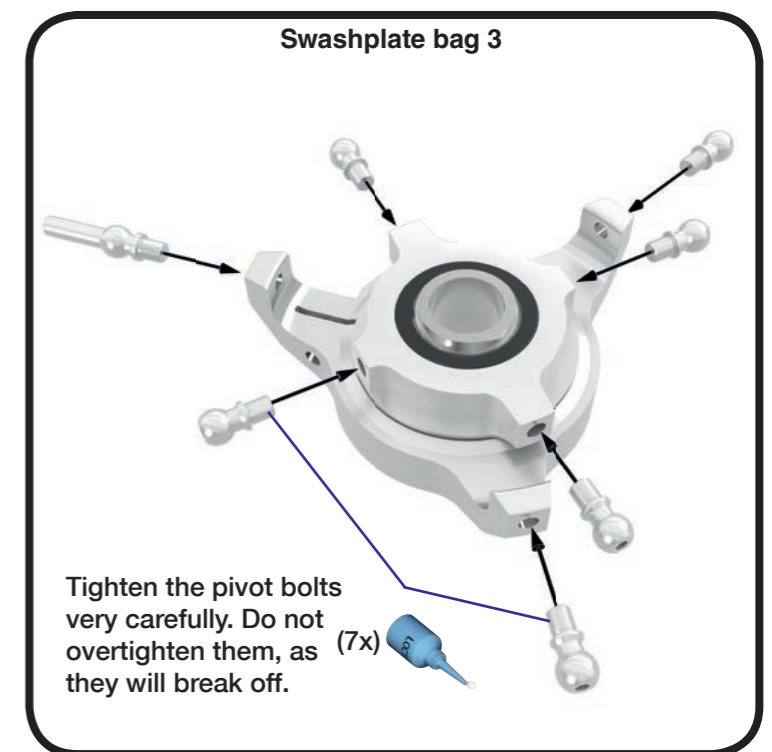
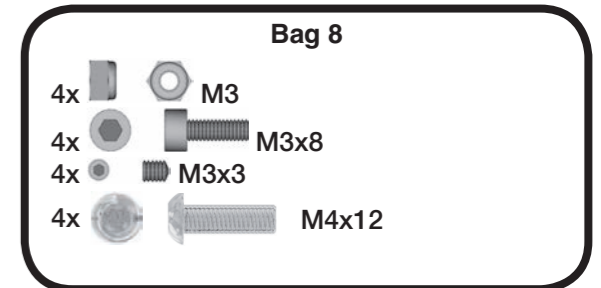
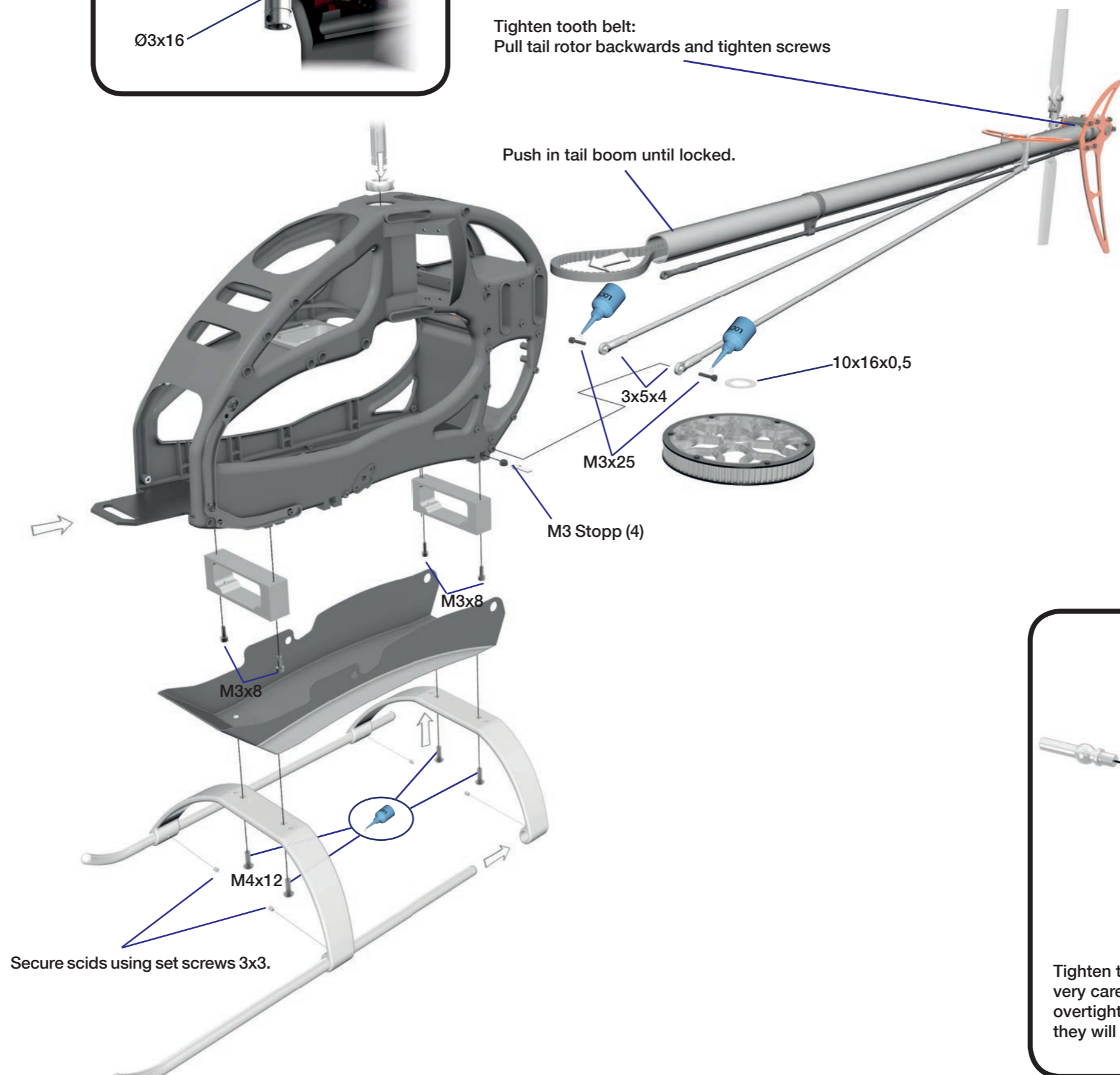
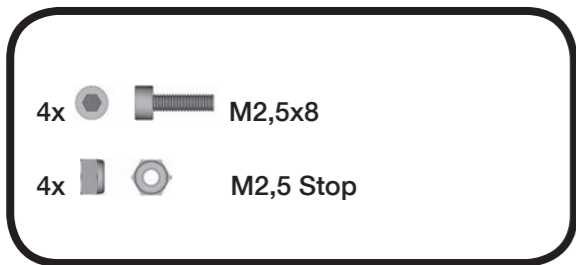
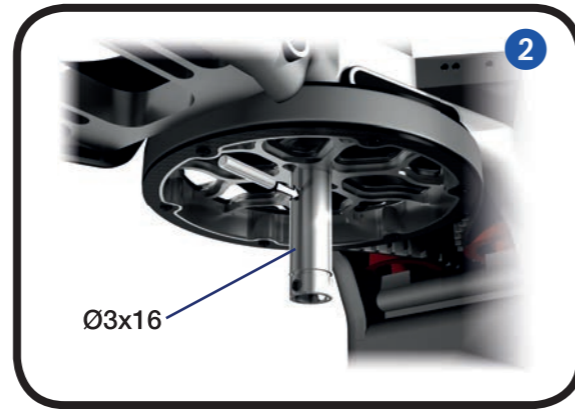
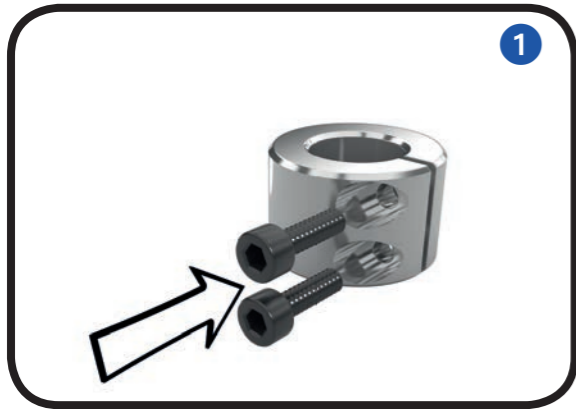

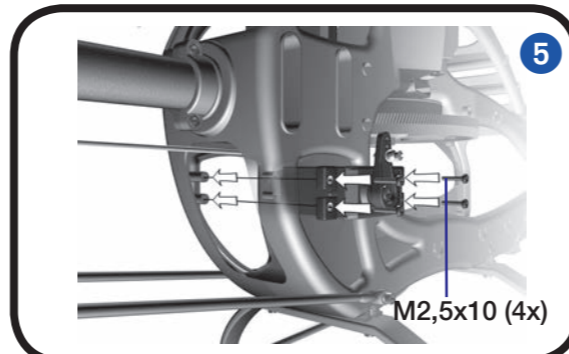
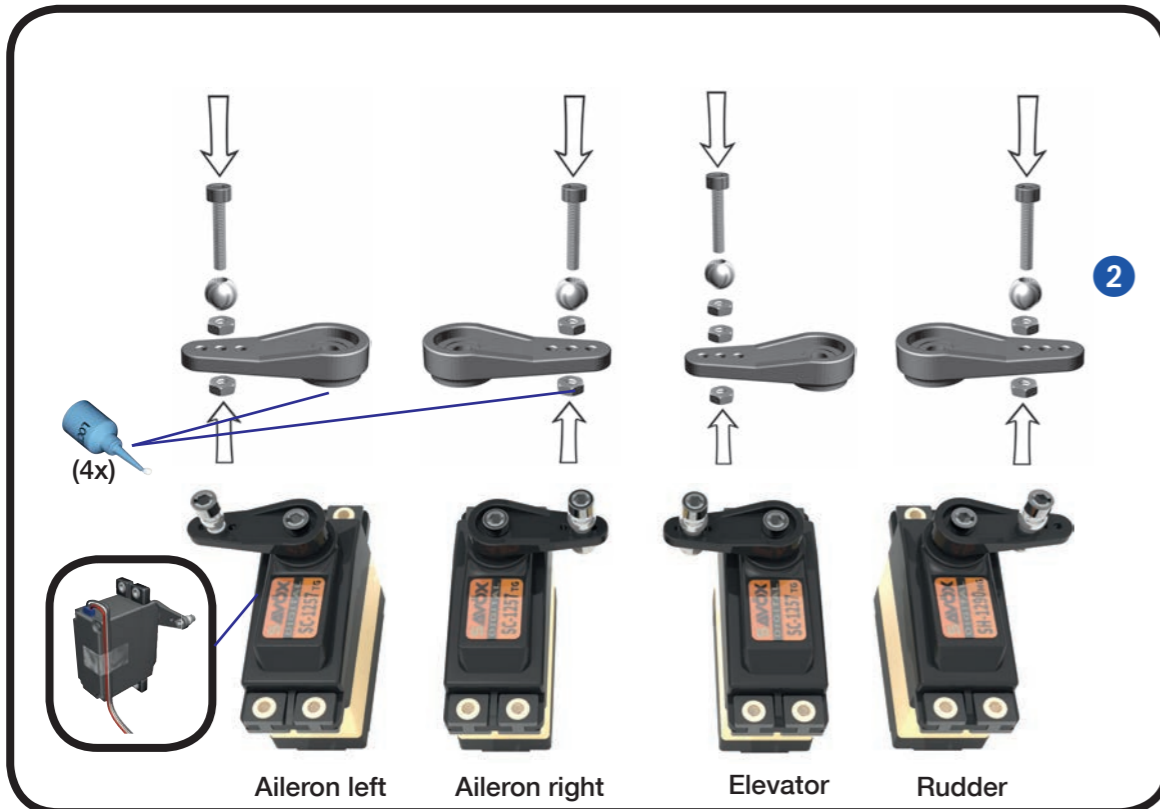
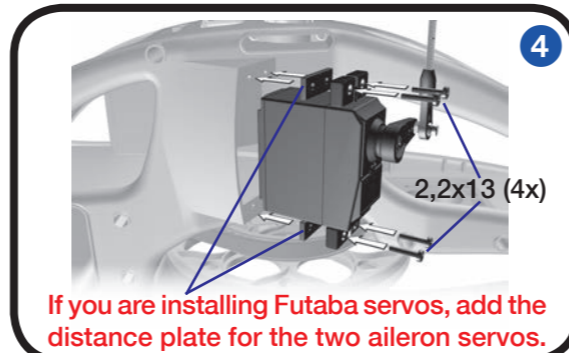
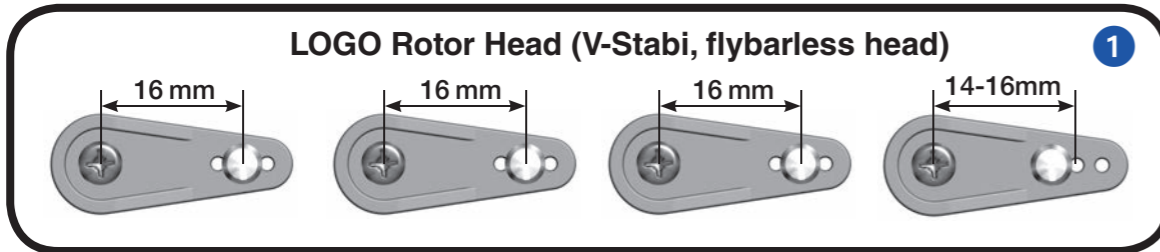

Using the two spacer washers (3x5x1.2), you can adjust the fitting of the canopy. Without the washers, the edges will overlap. If washers are used, edges are touching slightly.

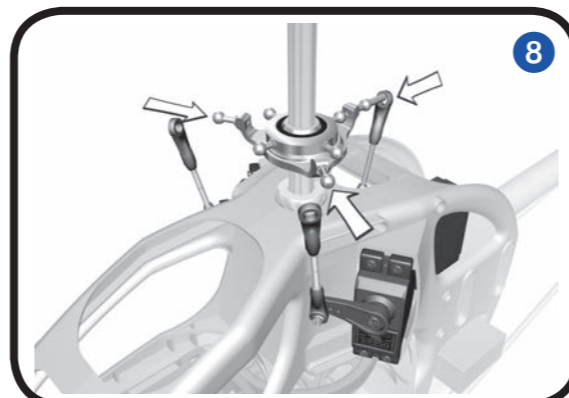
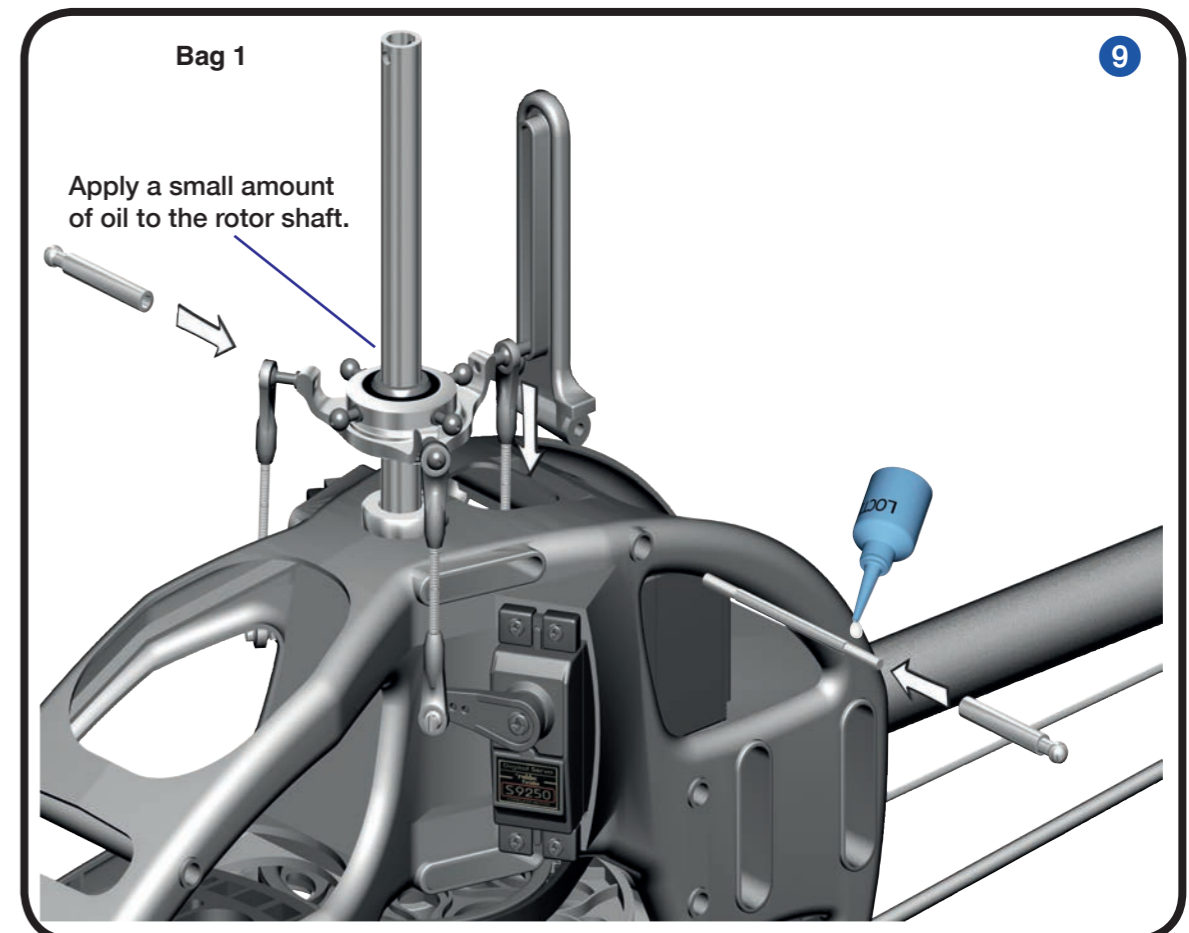
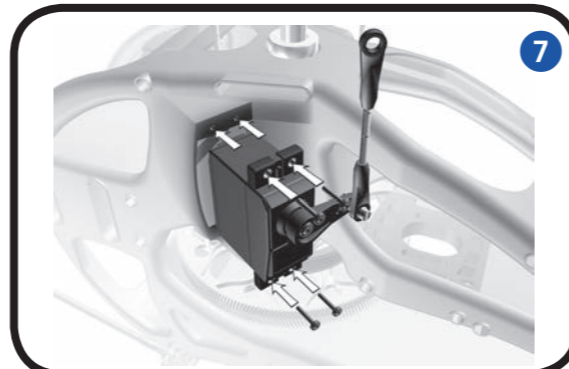
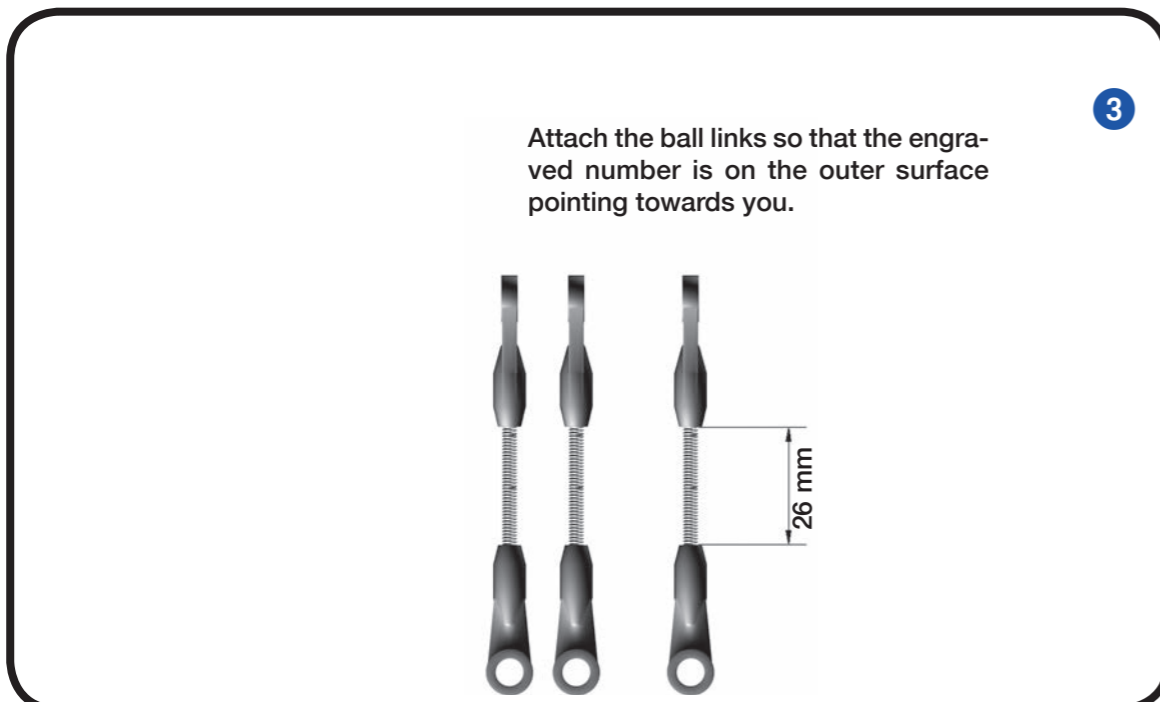
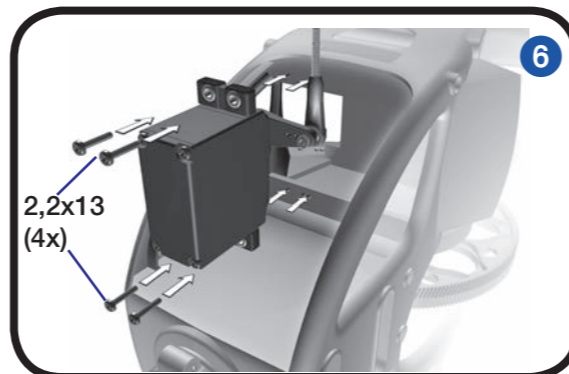

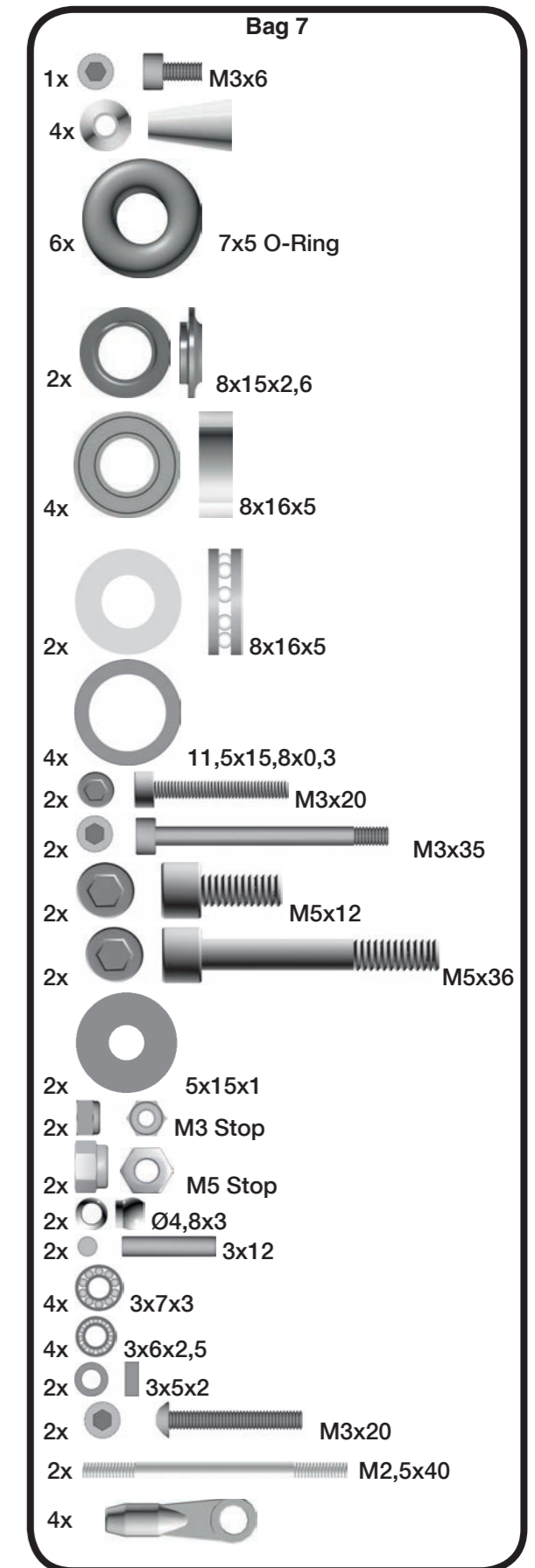
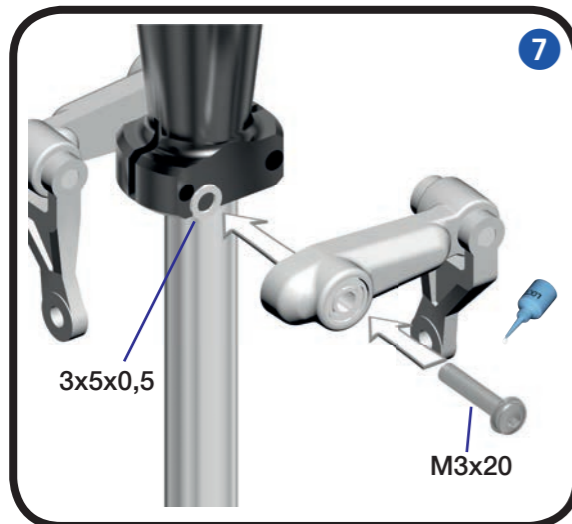
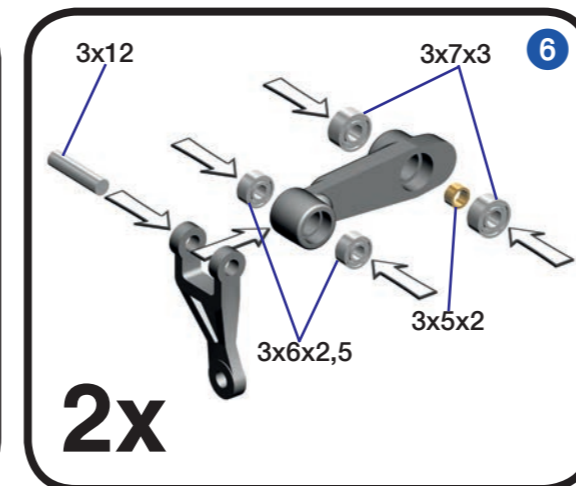
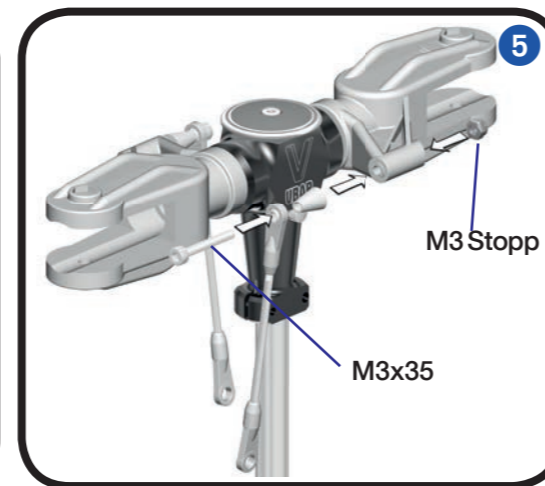
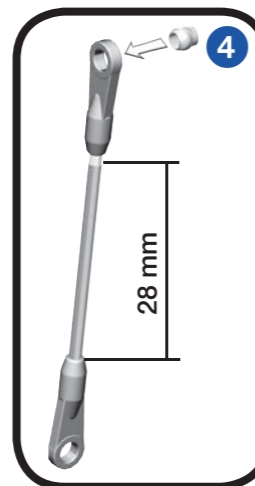
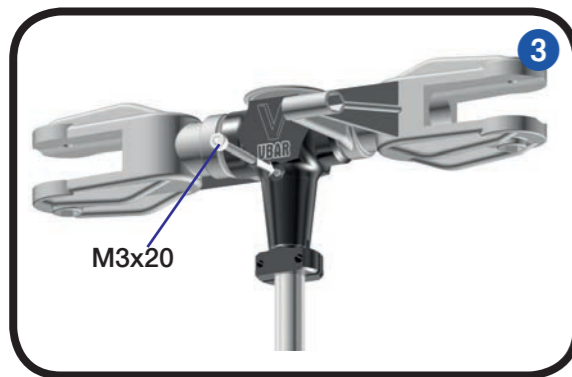
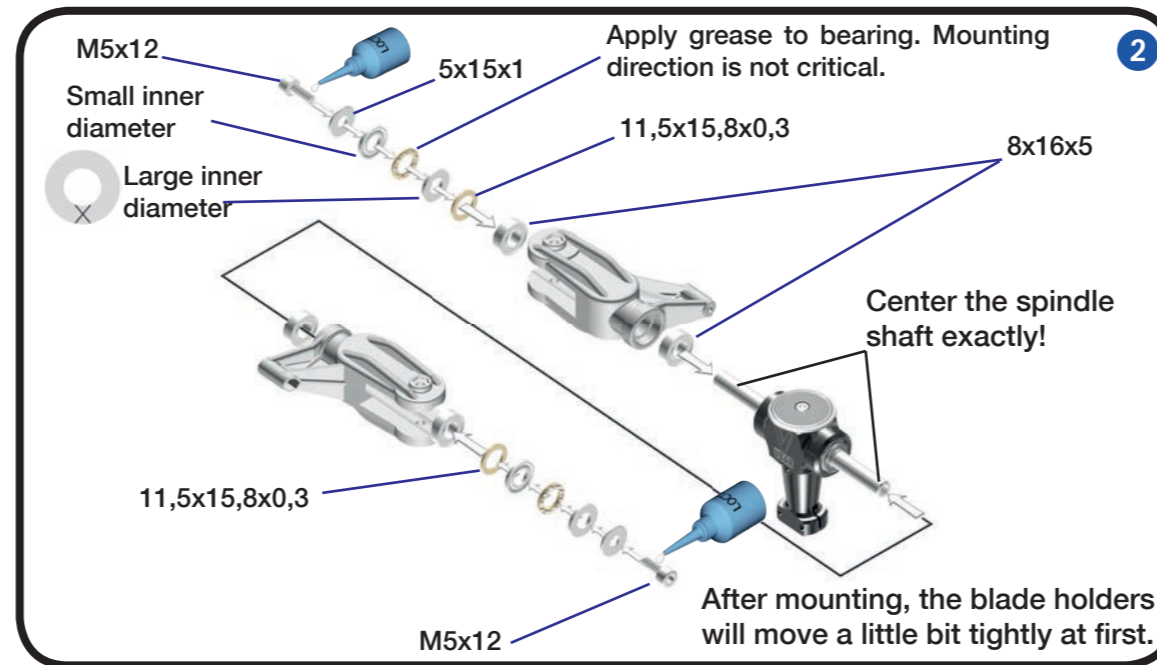
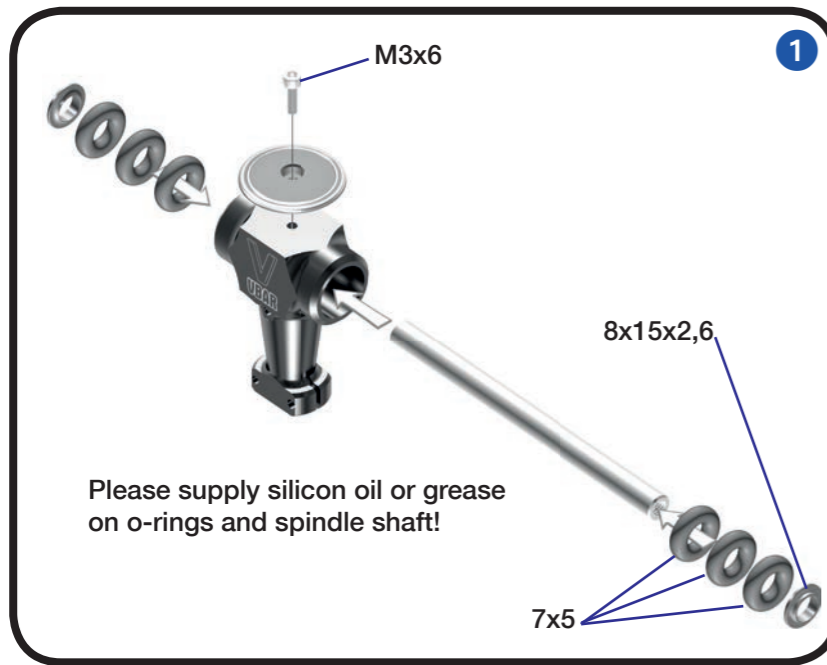

7 Mounting the Motor

8 Mounting the Canopy

Bag 1,2

Scorpion Motor HK-4525-370Kv

1

15 teeth pinion, module 1

6x 6x9x0,2

M4x32

Please mount the motor, motor plate, pinion and counterbearing as illustrated in the above picture. When positioning the pinion, please ensure that it sits exactly on the ball bearing of the counterbearing with only one shim (6.9x0.2) inbetween. Also make sure that the M4 set screw sits on the flattened area of the motor shaft.

For mounting the new motor counterbearing with rotorshaft support, please follow these steps: First, mount the main gear, the rotor shaft assembly and all shims. Secure assembly with the 10 mm c-clip (Picture 2). The main gear will have 0.5 mm axial play. This is normal and will facilitate the mounting and positioning of the pinion later on. Now mount the motor and the counterbearing. Once the motor position is set (please ensure correct gear back-lash!), please screw the rotorshaft support onto the counterbearing, using the three M3x6 screws.

Bag 2

2x M3x22

4x 3x5x9

2x

Bag 2

4x M3x8

6x 6x9x0,2

2x M4x32

3x M3x6

1x 10x16x0,5

2

10x16x0,5

apply grease

Bag 2

To secure and protect the canopy in the lower area of the front landing bow, please mount the edge protector and secure it with speed glue.

Bag 2

Installation of the Motor Pinion
Screw the motor pinion onto the motor shaft, making sure that it can still be moved. Now mount the motor on the motor plate and move the pinion so it is aligned well with the main gear. As visual help for aligning the pinion you may use the small ridge which separates the two parts of the pinion. When the pinion is aligned correctly it will easily engage with the main gear. If the pinion does not engage with the main gear, it is not correctly aligned. After the pinion is correctly aligned, take the motor out of the mainframe and tighten the set screw.

Gear Backlash
Move the motor with the pinion until it is limited by the gear. Tighten one of the M4x32 screws slightly. You must still be able to swivel the motor around its own axis. In this way you can easily determine the correct distance between the main gear and the pinion. There should be no (!) gear backlash. At the same time, the motor should not (!) exert any pressure onto the running surface of the main gear. After you have determined the correct distance, tighten the second M4x32 screw.

