

60 Class

2-cycle engine

90 Class

4-cycle engine

MESSERSCHMITT ME-108

“Taifun”

BUILDING INSTRUCTIONS / MONTAGEANLEITUNG



SPECIFICATIONS

Wingspan	1625mm
Length	1300mm
Flying weight	2900g
Electric Motor	800 Watt (BOOST 60)
Glow Engine	10cc 2T / 15cc 4-T
Radio	6 Channel / 7 Servos

Technische Daten

Spannweite	1625mm
Länge	1300mm
Fluggewicht	2900g
Elektroantrieb	800 Watt (BOOST 60)
Verbrennerantrieb	10cc 2T / 15cc 4T
Fernsteuerung	6 Kanal / 7 Servos



WARNING! This radio controlled model is NOT a toy. If modified or flown carelessly it could go out of control and cause serious human injury or property damage. Before flying your airplane, ensure the air field is spacious enough. Always fly it outdoors in safe areas and seek professional advice if you are unexperienced.

ACHTUNG! Dieses ferngesteuerte Modell ist KEIN Spielzeug! Es ist für fortgeschrittene Modellflugpiloten bestimmt, die ausreichende Erfahrung im Umgang mit derartigen Modellen besitzen. Bei unsachgemäßer Verwendung kann hoher Personen- und/oder Sachschaden entstehen. Fragen Sie in einem Modellbauverein in Ihrer Nähe um professionelle Unterstützung, wenn Sie Hilfe im Bau und Betrieb benötigen. Der Zusammenbau dieses Modells ist durch die vielen Abbildungen selbsterklärend und ist für fortgeschrittene, erfahrene Modellbauer bestimmt.

REQUIRED FOR OPERATION (Purchase separately) BENÖTIGTE KOMPONENTEN FÜR DEN ABFLUG (Nicht enthalten)

12x6 for .60 - 4 cycle engine
13x7 for .90 - 4 cycle engine
14X8 for Quantum 4120/07
BOOTS 60

Phoenix-60 Brushless Motor Control or equivalent.

Extension for aileron servo, retract servo.

Retract landing gear VQAR10

Retract servo x1

Linkage Stopper x2 (for retract servo)

Brushless Motor BOOST 60

Li-Po Battery, 14.8V, 4500mAH (25C)

Minimum 6 channel radio for airplane with 7 servos
.Motor control x1 .Aileron x2
.Elevator x1 .Rudder x1
.Flap x 2

.60 - 2 cycle

.90 - 4 cycle

Silicone tube

GLUE (Purchase separately)



Cyanoacrylate
Glue
Klebstoff



Epoxy Glue (5 minute type)
Epoxy-Klebstoff (5min-Typ)



Epoxy Glue (30 minute type)
Epoxy-Klebstoff (30min-Typ)

TOLLS REQUIRED (Purchase separately)

Hobby knife

Phillip screw driver

Hex Wrench

Needle nose Pliers

Awl

Sander

Scissors

Wire Cutters

Masking tape - Straight Edged Ruler - Pen or pencil - Rubbing alcohol - Drill and Assorted Drill Bits

If exposed to direct sunlight and/or heat, wrinkles can appear. Storing the model in a cool place will let the wrinkles disappear. Otherwise, remove wrinkles in covering film with a hair dryer, starting with low temperature. You can fix the corners by using a hot iron.

Bei Sonneneinstrahlung und/oder Wärme kann die Folie erschlaffen bzw. Falten entstehen. Verwenden Sie ein Warmluftgebläse (Haartrockner) um evtl. Falten aus der Folie zu bekommen. Die Kanten können Sie mit einem Bügeleisen behandeln. Nicht zuviel Hitze anwenden !

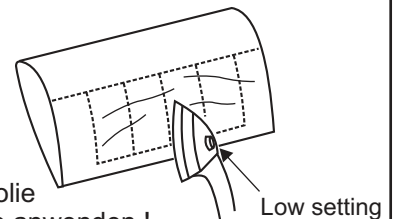

1.5mm Drill holes using the stated size of drill (in this case 1.5 mm Ø)	Take particular care here	Hatched-in areas: remove covering film carefully	Check during assembly that these parts move freely, without binding
Use epoxy glue	Apply cyano glue	Assemble left and right sides the same way.	Not included. These parts must be purchased separately

1.5mm Löcher bohren mit dem angegebenen Bohrer (hier 1,5 mm)	Hier besonders aufpassen	Schraffierte Stellen, Bespannfolie vorsichtig entfernen	Während des Zusammenbaus immer prüfen, ob sich die Teile auch reibungslos bewegen lassen
Epoxy-Klebstoff verwenden	Sekundenkleber auftragen	Linke und rechte Seite wird gleichermaßen zusammgebaut	Nicht enthalten. Teile müssen separat gekauft werden.

Read through the manual before you begin, so you will have an overall idea of what to do.

CONVERSION TABLE

1.0mm = 3/64"	3.0mm = 1/8"	10mm = 13/32"	25mm = 1"
1.5mm = 1/16"	4.0mm = 5/32"	12mm = 15/32"	30mm = 1-3/16"
2.0mm = 5/64"	5.0mm = 13/64"	15mm = 19/32"	45mm = 1-51/64"
2.5mm = 3/32"	6.0mm = 15/64"	20mm = 51/64"	

1- Joining the wing / Flächenverbindung

TOP VIEW / AUFSICHT

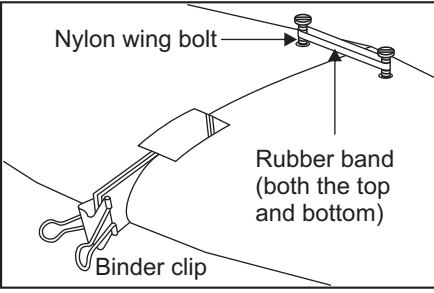
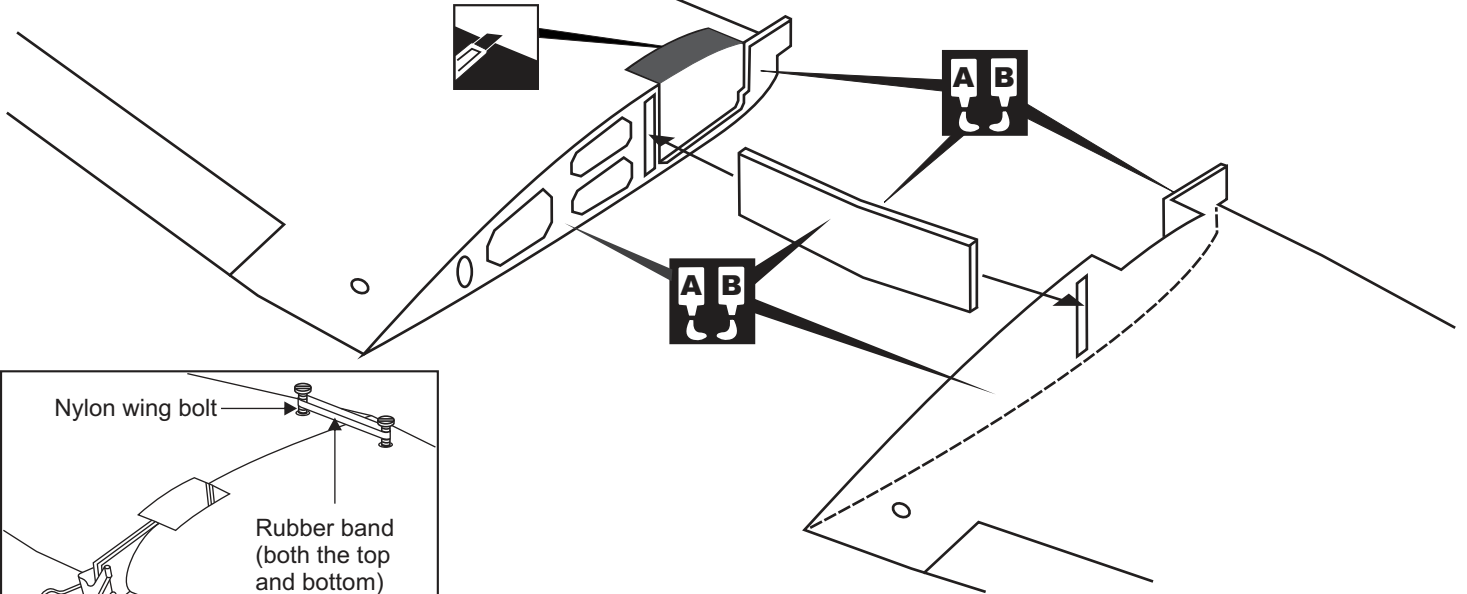

IMPORTANT: Please do not clean off the excess epoxy on the wing with strong solvent or pure alcohol, only use kerosene to keep the colour of your model not fade.

2- Retract Servo mount / Servoaufnahmen

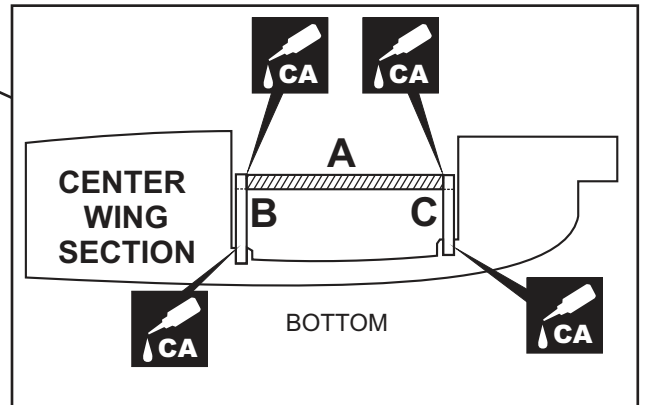
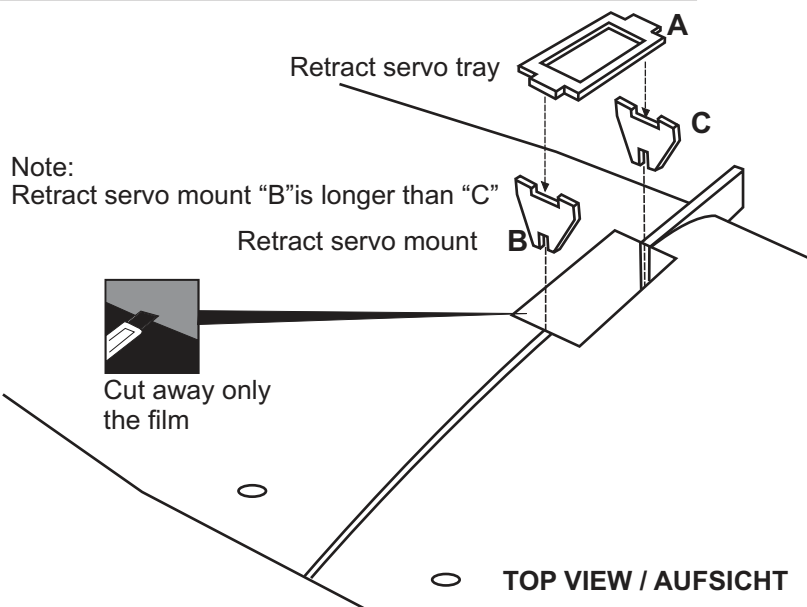

3- Retract servo / Einziehfahrwerk servo

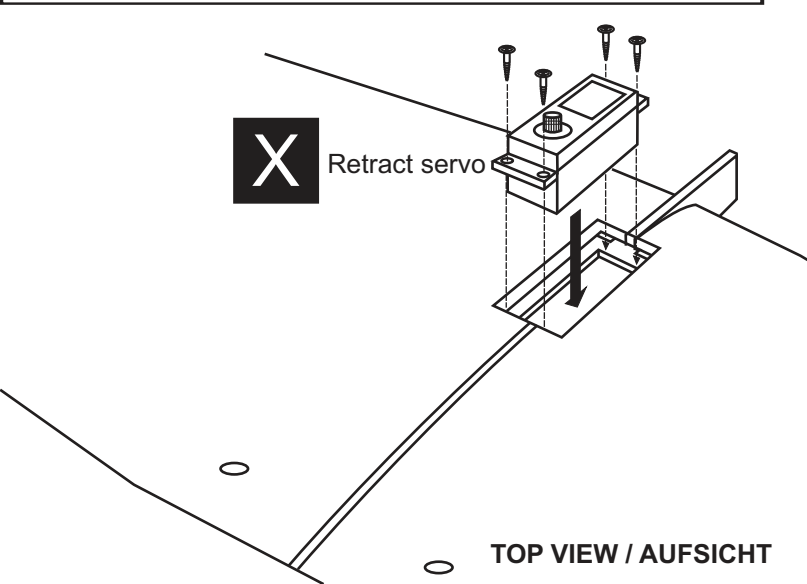

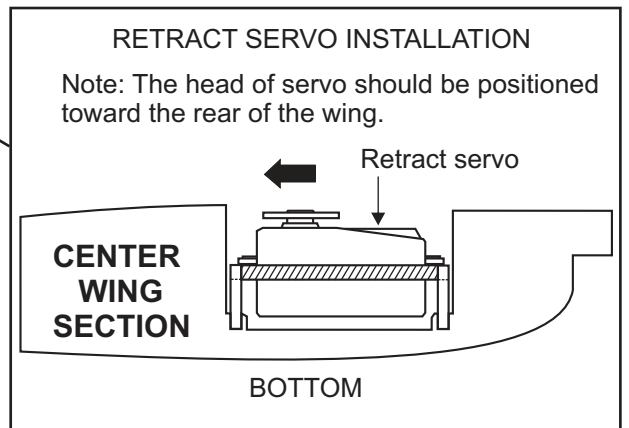

Install the retract servo onto the retract servo mount and secure it in place with four screw (included with radio set).



4- Flap, Aileron servo / Flap, querruder servo

WING - BOTTOM VIEW UNTERSICHT

- Connector 2mm
 4
- Plastic control horn
 4 set

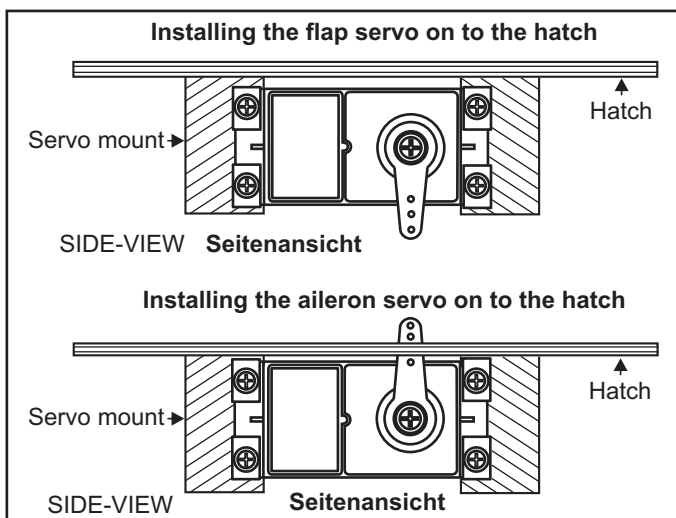
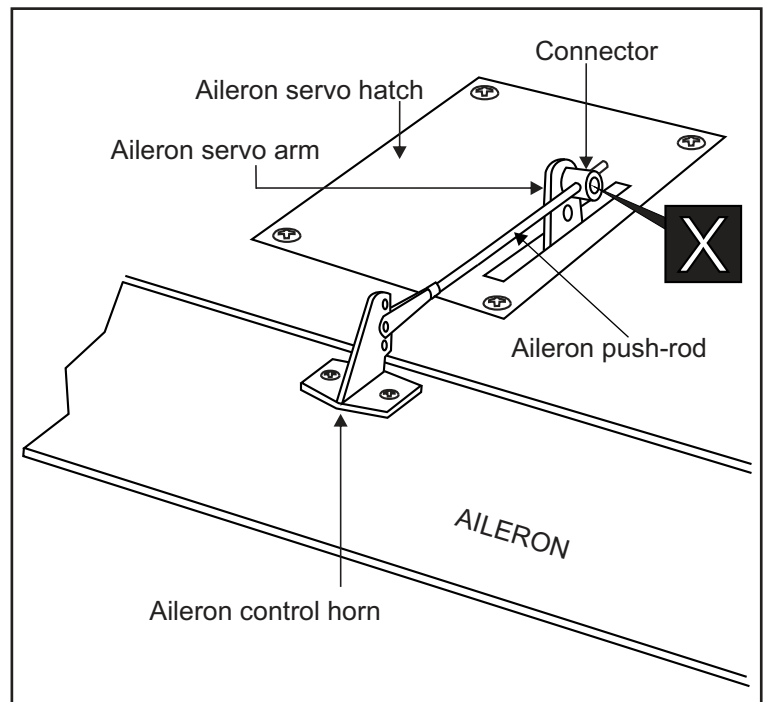
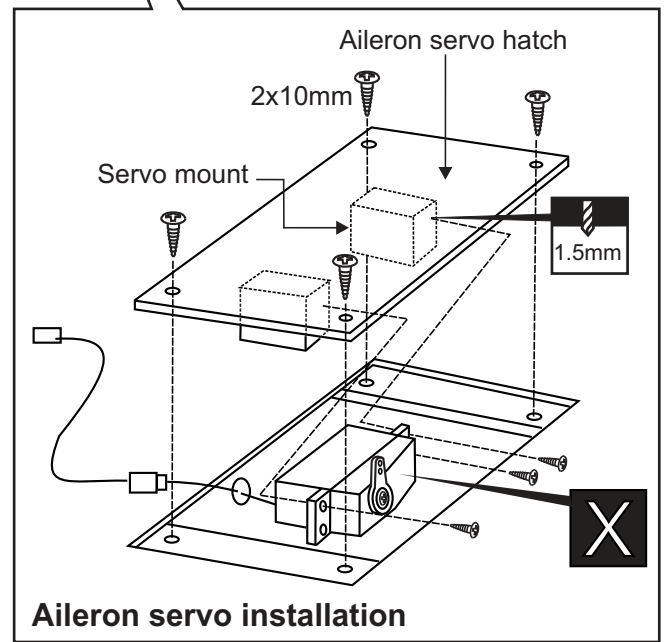
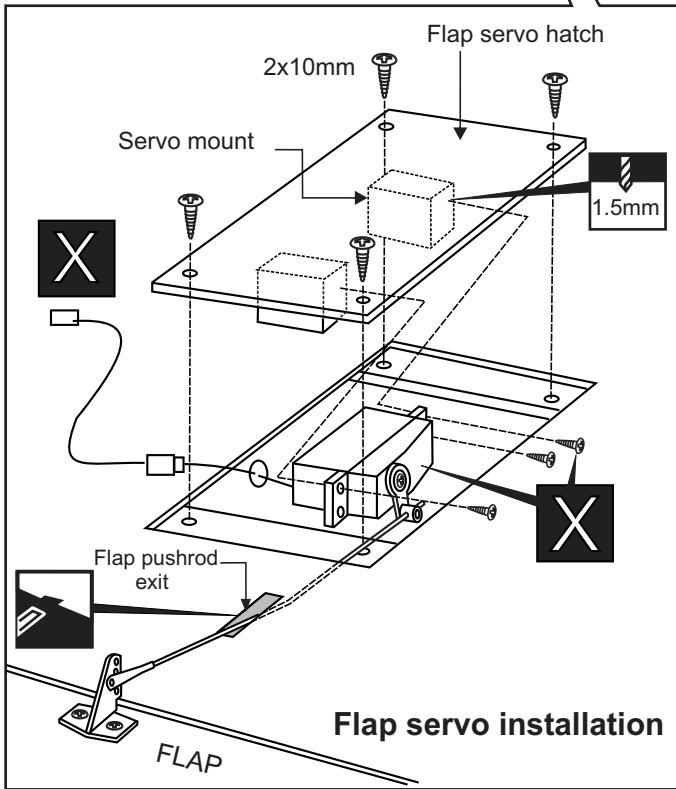
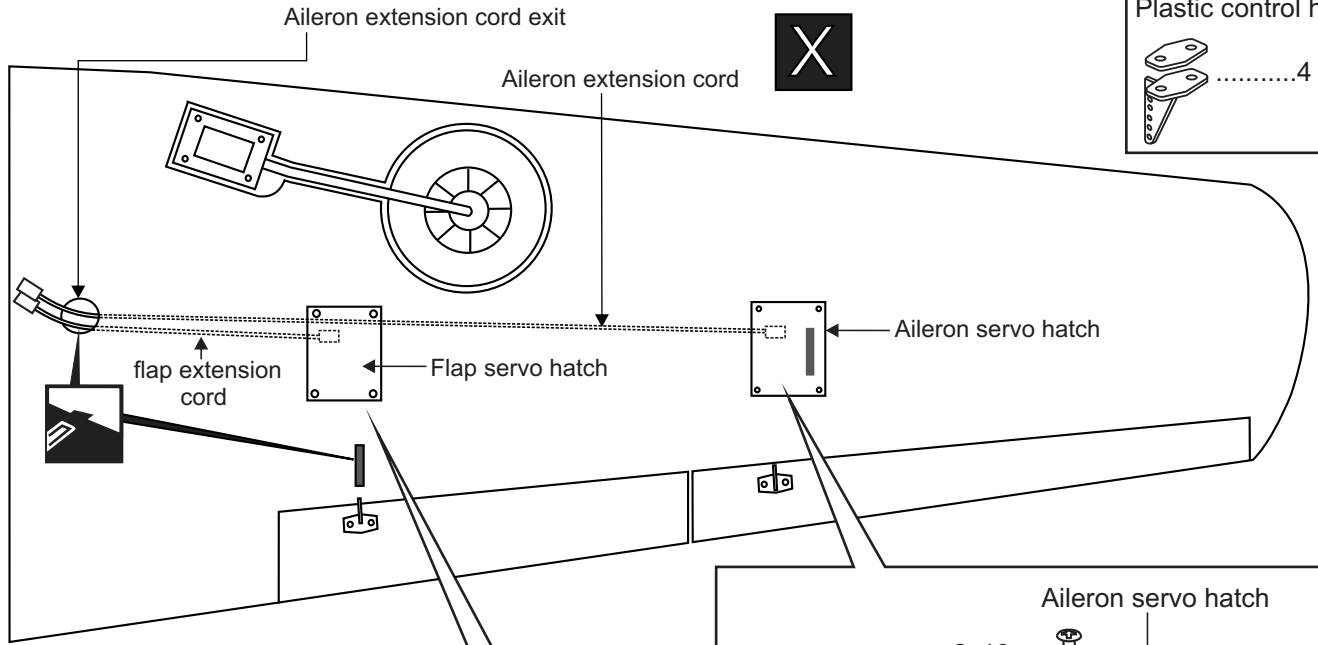

5- Retract landing gear / Einziehfahrwerk

Clevis ...2



Connector ...2



Trial fit the push rod into the wing. Join the pushrod to the retract gear arm and trial fit the retract into the wing.

Pull and push the retract push rod by hand to be sure to adjust the stroke so that the landing gear locks in both up and down position.

Do the same way with other half wing.

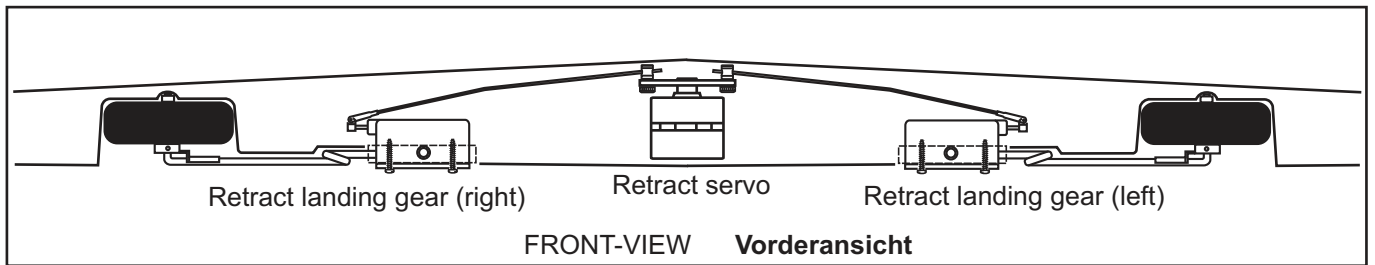
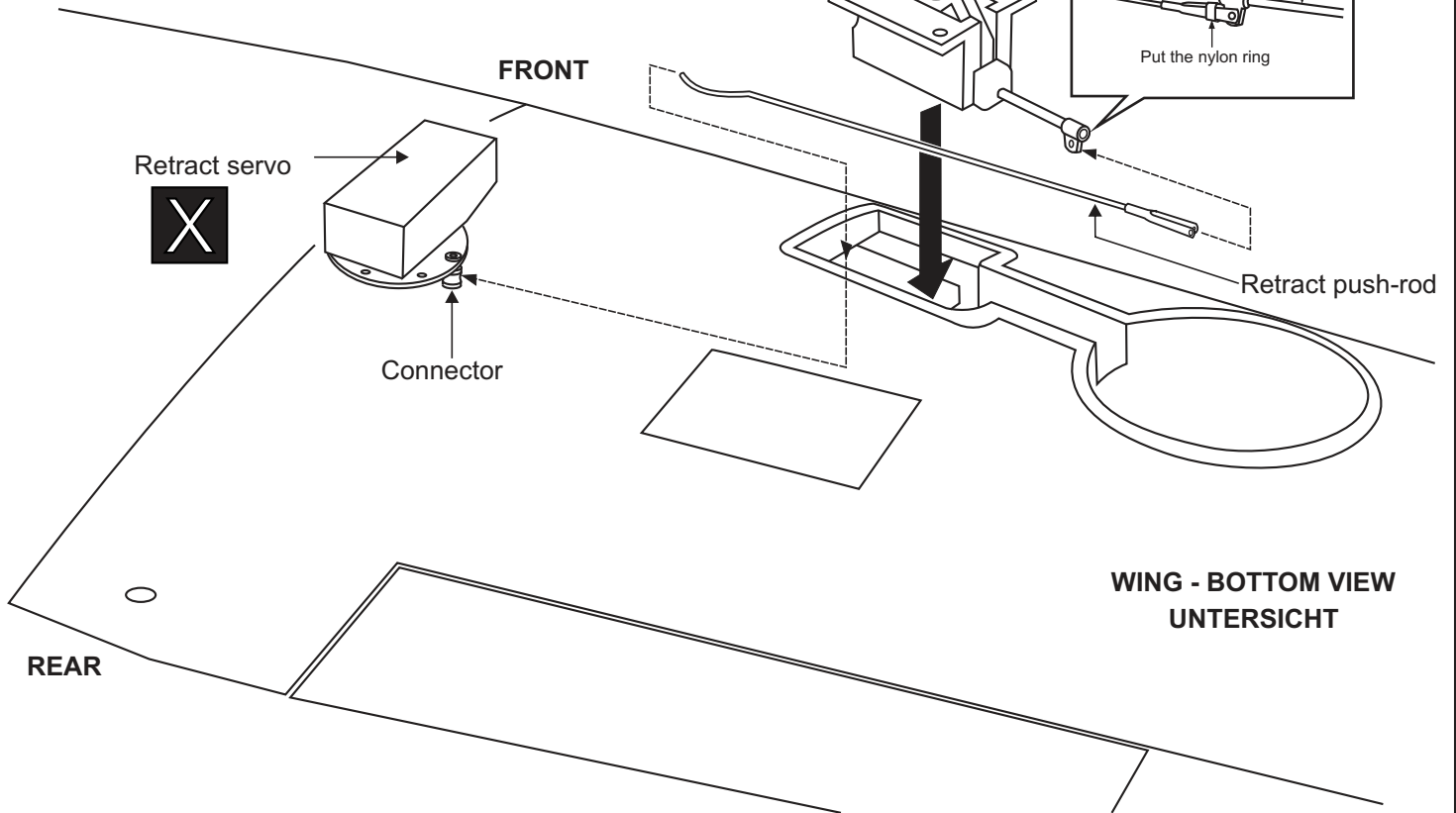

6- Retract landing gear / Einziehfahrwerk

Do the same way with other half wing.

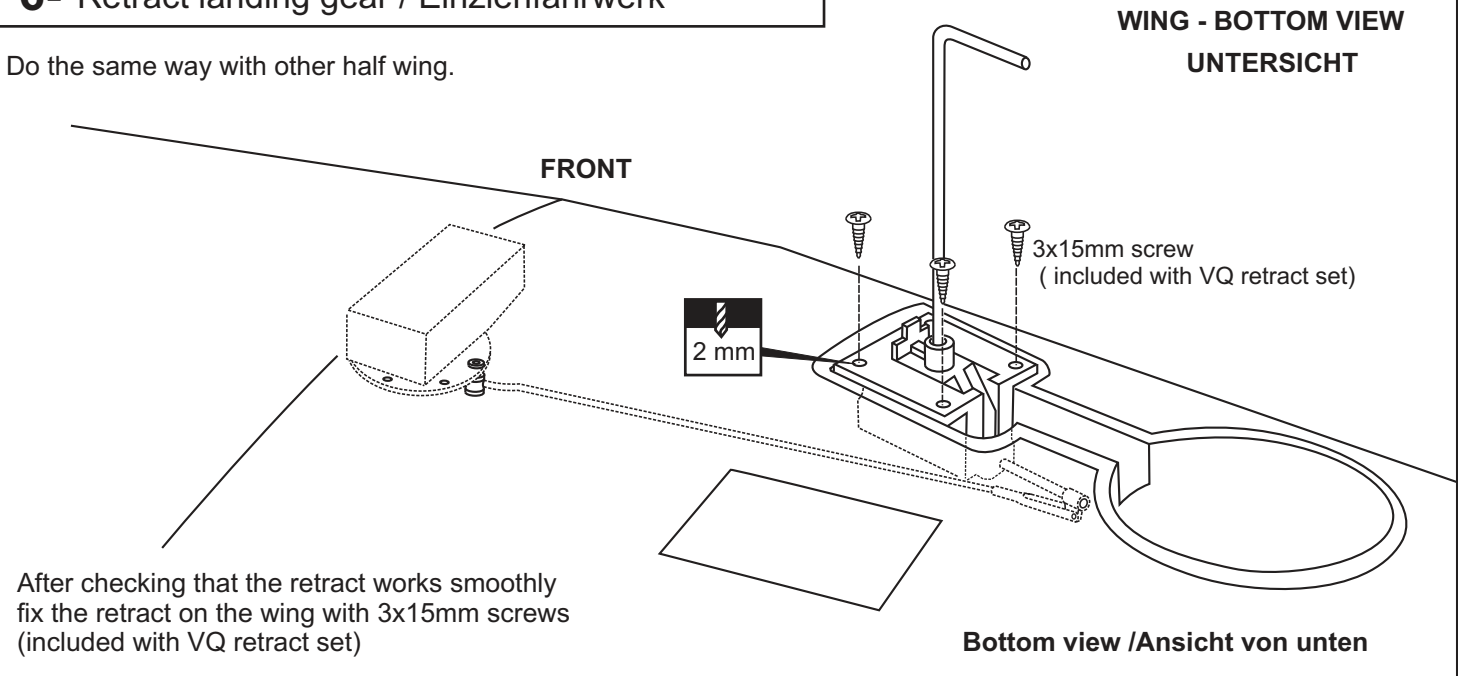

After checking that the retract works smoothly fix the retract on the wing with 3x15mm screws (included with VQ retract set)

7- Fixed gear / Starres Fahrwerk

3x20mm screw

8

3x20mm screw

16

Nylon gear strap

4

Main landing gear

Gear mount

1

3x20mm

Nylon gear strap

2

2mm

Ply gear mount flat

Square plastic

2mm

3

3x20mm

8- Fixed gear / Starres Fahrwerk

Do the same way with other half wing.

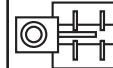
2

5/32" (4mm) collar

2

1/8x13/32" (3x12mm)

8

5/64x15/64" (2x6mm)

4

FRONT

3x12mm screw

2 mm

WING - BOTTOM VIEW

UNTERSICHT

Gear cover

5/64
(2x6mm)
screw

1/16
1.5mm

Gear strap



9- Fixed gear / Starres Fahrwerk

Do the same way with other half wing.

WING - BOTTOM VIEW

UNTERSICHT

FRONT

ABS Wheel well cover



10- Horizontal Stabilizer / Höhenleitwerk

- 1-Trial fit the horizontal stabilizer in place . Check the alignment of the horizontal stabilizer. When you are satisfied with the alignment, use a pencil to trace around the right and left of the stabilizer where it meets the fuselage.
- 2-Remove the horizontal stabilizer from the fuselage. Using the sharp hobby knife, carefully cut away the covering inside the lines which were marked above.

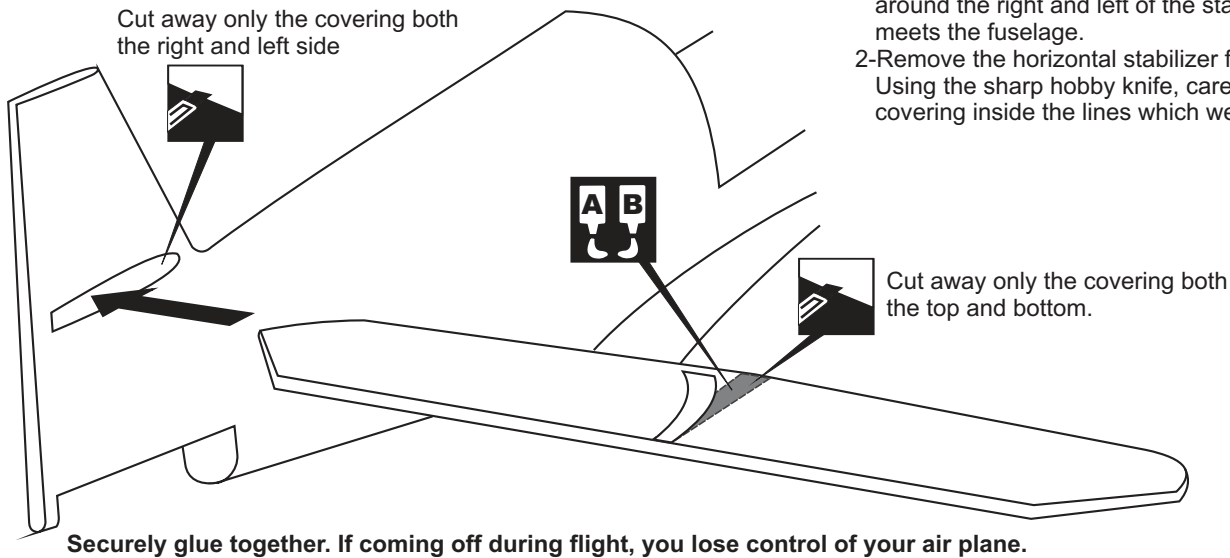

11- Horizontal Stabilizer / Höhenleitwerk

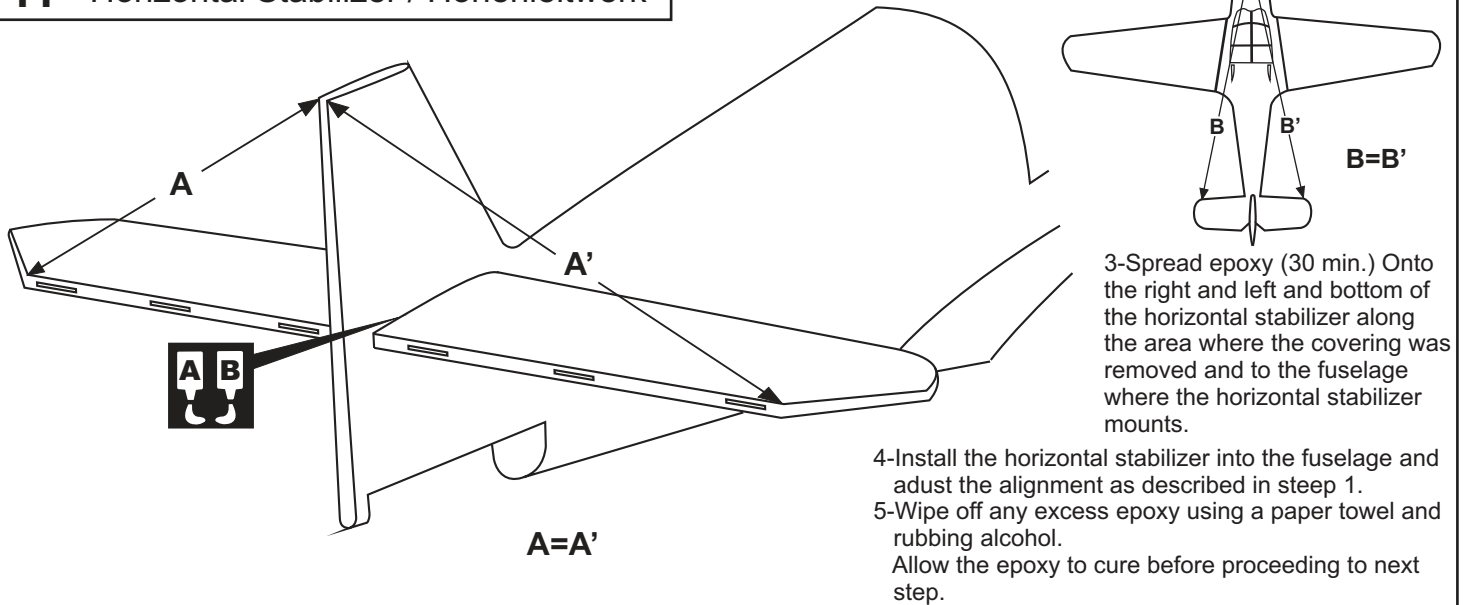

12- Elevator / Höhenruder

Apply a thin layer of machine oil or petroleum jelly to only the pivot point of the hinges on the elevator, then push the elevator and its hinges into the hinge slots in the trailing edge of the horizontal stabilizer. There should be a minimal hinge gap.

When satisfied with the and alignment, hinge the elevator to the horizontal stabilizer using 5 minute epoxy. Make sure to apply a thin layer of epoxy to the top and bottom of both hinges and to inside the hinge slots. Repeat the previous procedures to hinge the second elevator to the other side of the horizontal stabilizer.

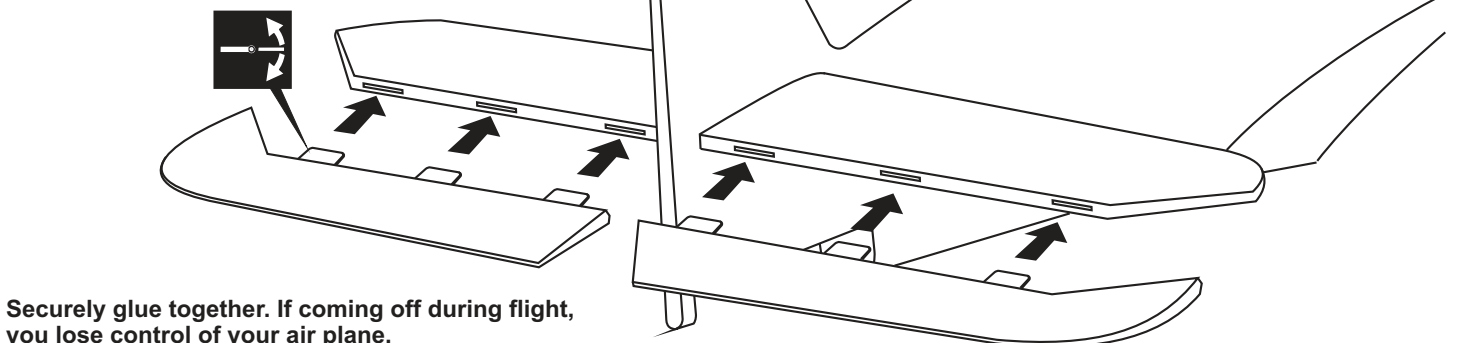
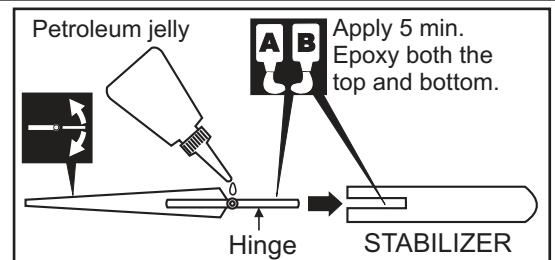

13- Rudder / Seitenruder

Plastic control horn



.....3 set

Apply a thin layer of machine oil or petroleum jelly to only the pivot point of the hinges on the rudder, then push the rudder and its hinges into the hinge slots in the trailing edge of the vertical stabilizer. There should be a minimal hinge gap. When satisfied with the alignment, hinge the rudder to the vertical stabilizer using 5 minute epoxy. Make sure to apply a thin layer of epoxy to the right and left of both hinges and to inside the hinge slots.

Securely glue together. If coming off during flight, you lose control of your air plane.

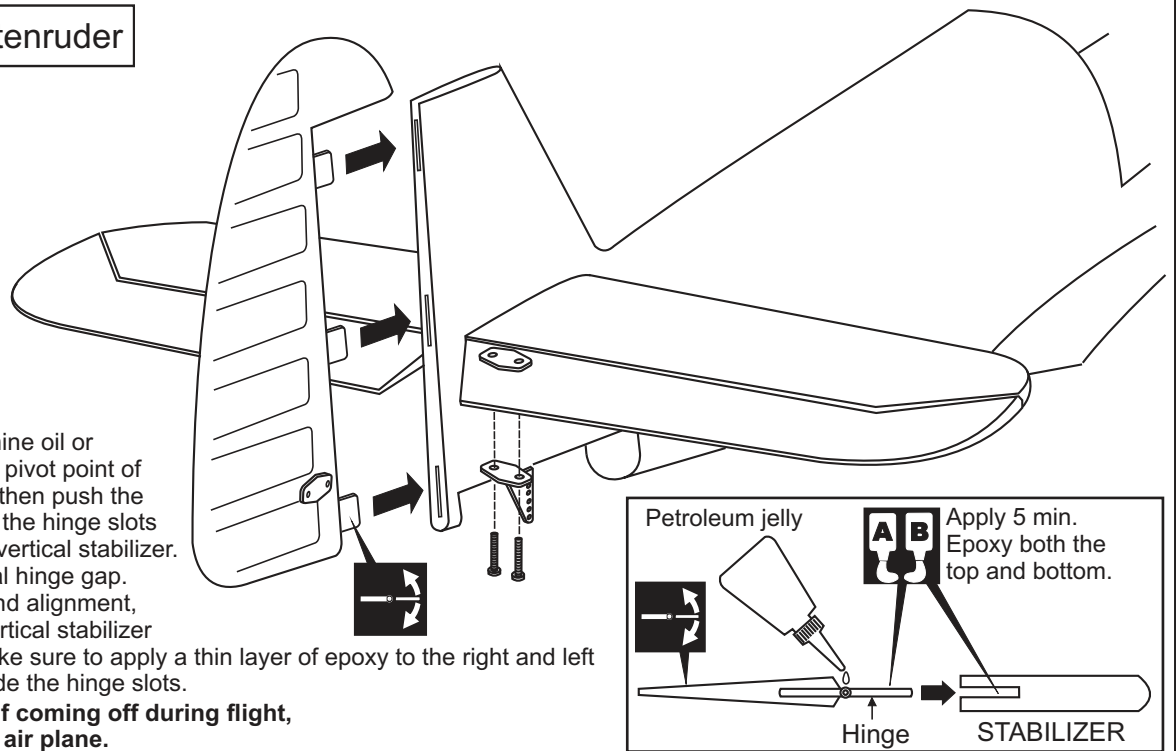

Petroleum jelly

A B

Apply 5 min. Epoxy both the top and bottom.

Hinge STABILIZER

14- Tail gear / Heckfarwerk

BOTTOM VIEW
UNTERSICHT

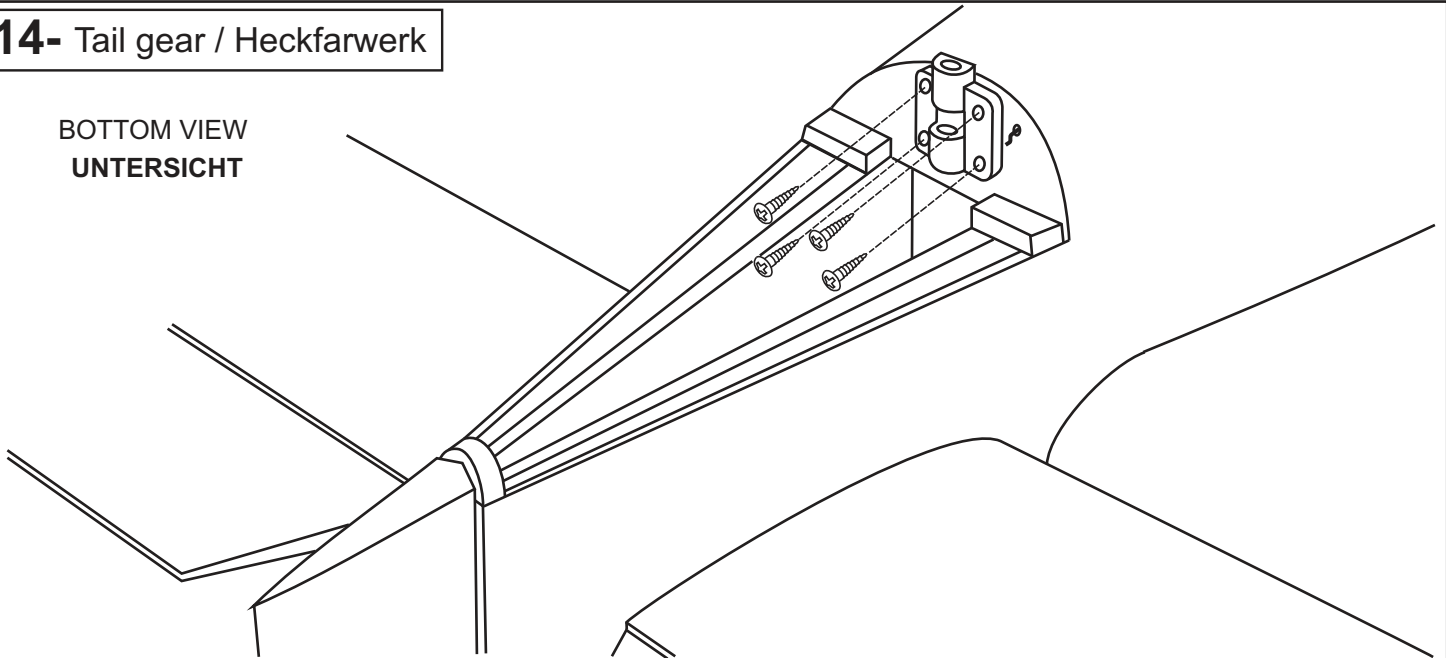

15- Tail gear / Heckfarwerk

2x3mm screw1

2mm I.D collar1

Tail wheel control-horn

Tail landing gear1

.....1

BOTTOM VIEW
UNTERSICHT

Tail wheel control arm

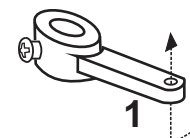

Tail wheel push-rod

- 1- Insert the tail wheel pushrod into the hole on the tail gear control horn (as show).
- 2- Install the tail wheel control horn in place.
- 3- Instal the tail wheel gear in place.
- 4- Secure the tail wheel control horn in place using a 5/64"(2mm) screw set, Ensure smooth non-binding movement.

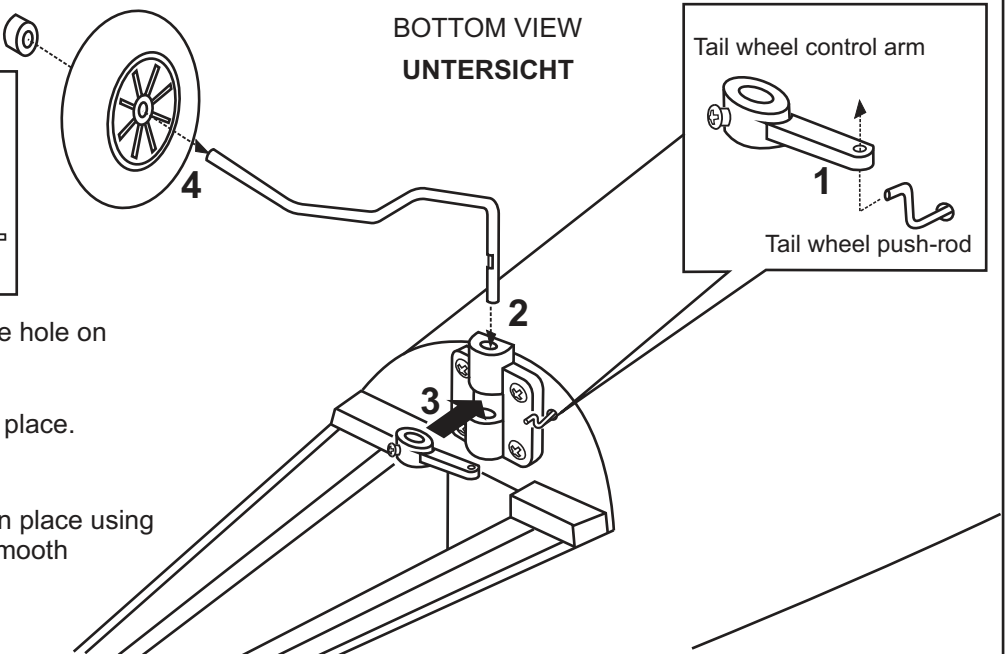

16- Tail Brace / Leierwerksstütze

- 1-Position the tail brace in place (1). Using the pencil mark the location of the two brace holes as show (2).
- 2-Remove the tail brace and drill two 1/16" (1.5mm) as show (3).
- 3-Slide the two ABS cover on to the right and left tail brace as show (4)
- 4-Position the tail brace again. Secure it in place with two 2x12mm screws (5)

Vis 3x12mm
4

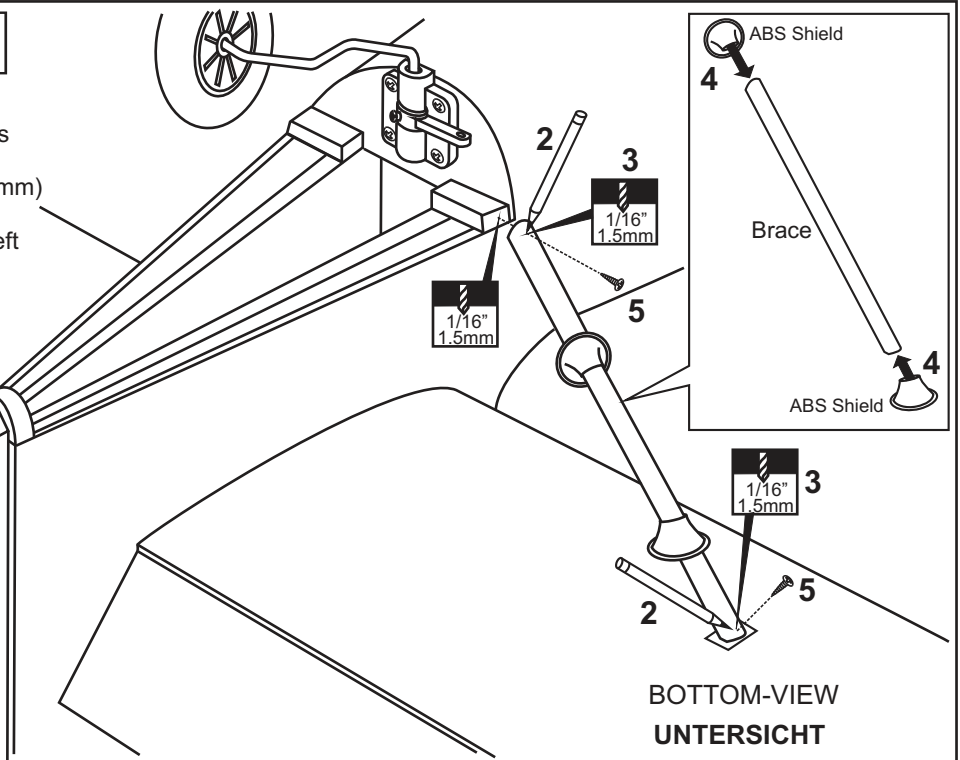
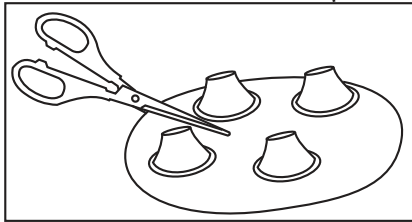





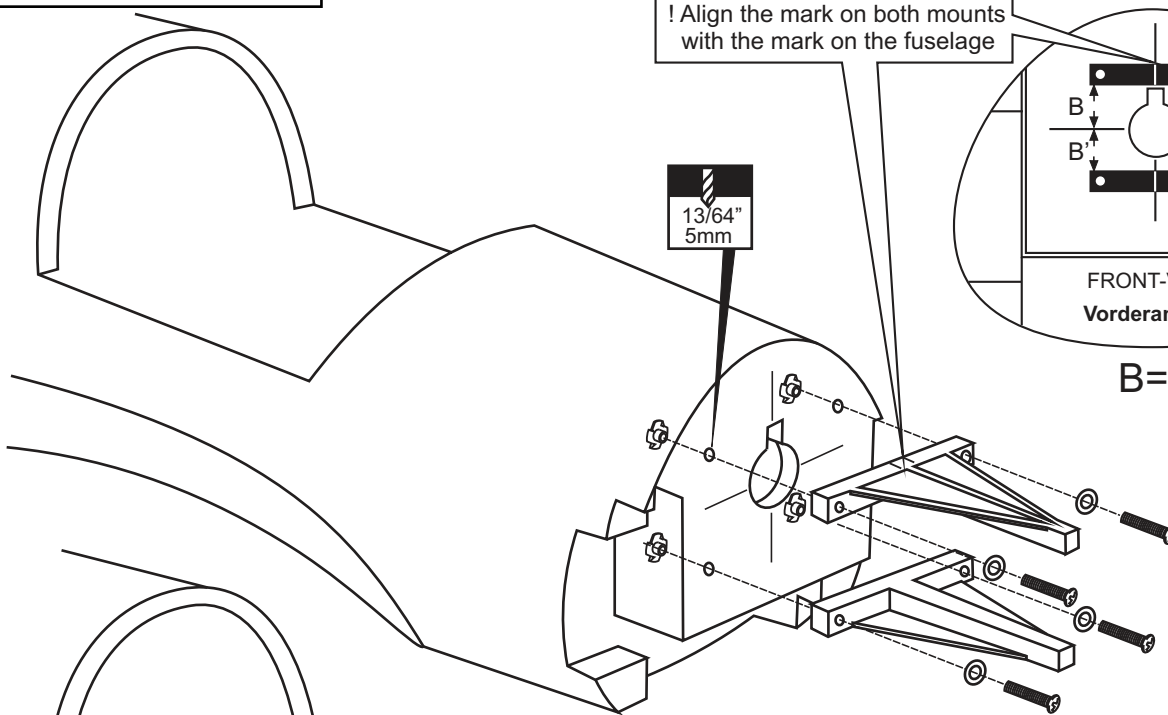
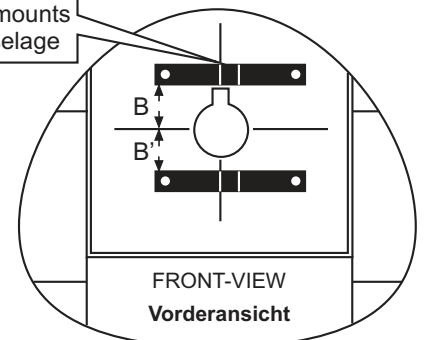

17- Engine / Motor

! Align the mark on both mounts with the mark on the fuselage

13/64"
5mm



! Engine thrust on balk head is already adjust at factory

- 1/8x5-1/64"
3x25mm screw
  ...4
- 1/8"(3mm) nut
4
- 5/32x1"
4x25mm screw
  ...4
- Blind-nut
4

18- Fuel tank / Treibstofftank

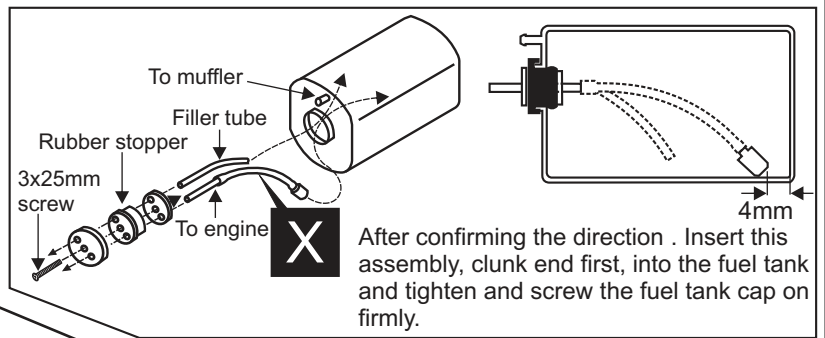

19- Brushless Motor

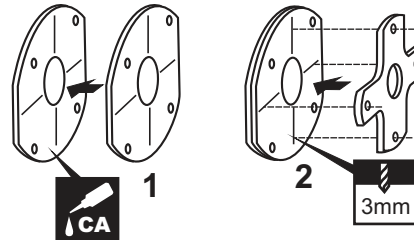

Using a aluminum motor mounting plate as a template, mark the plywood motor mounting plate where the four holes are to be drilled (2).

Remove the aluminum motor mounting plate and drill a 1/8"(3mm) hole through the plywood at each of the four marks marked .

Note: The aluminum motor mounting included with electric motor set.

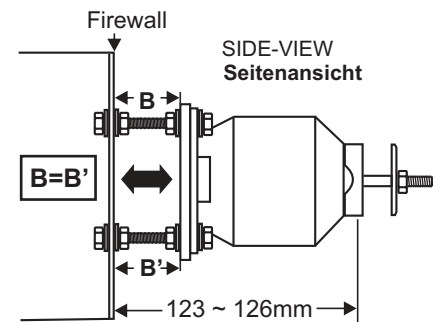
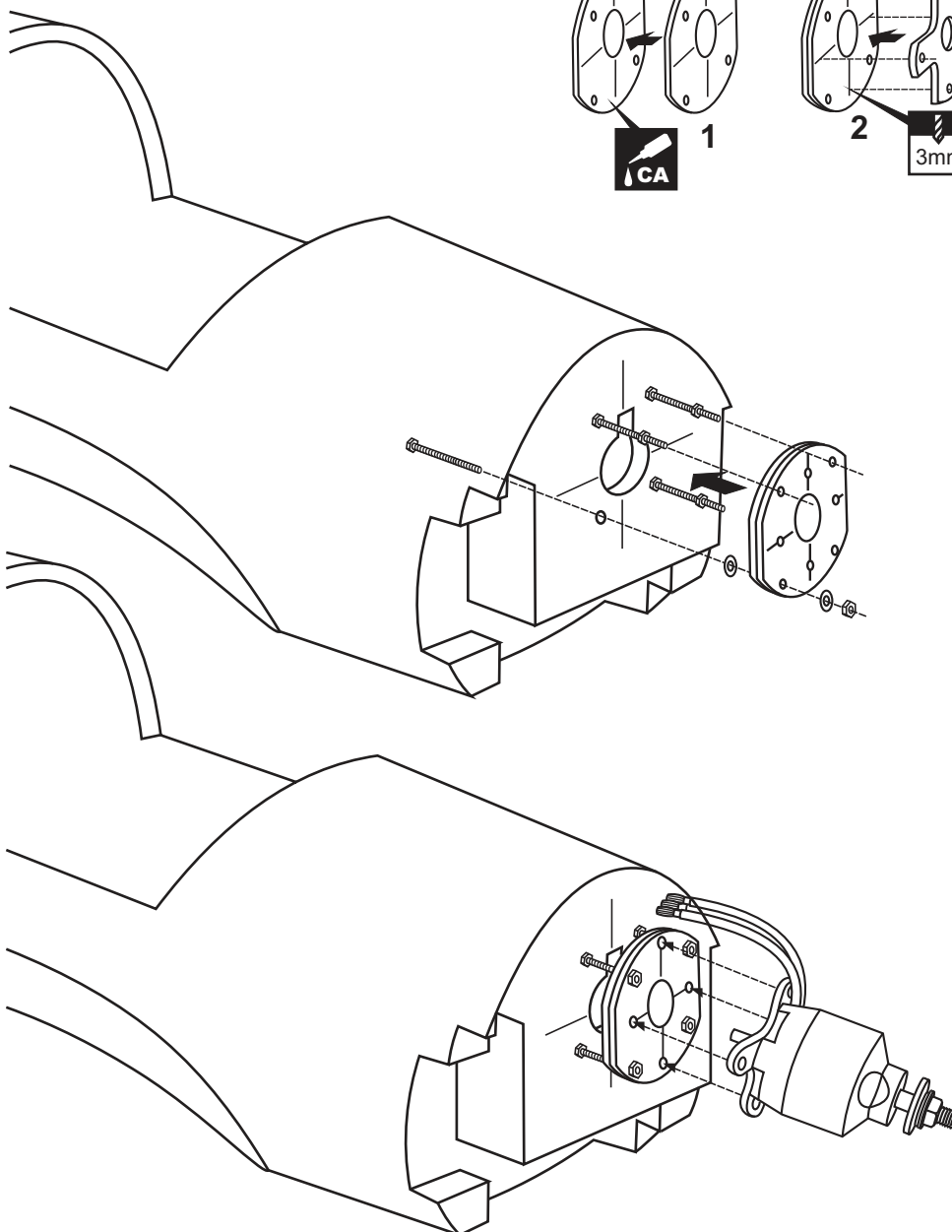

! Engine thrust on balk head is already adjust at factory

Sturz und Zug beachten!

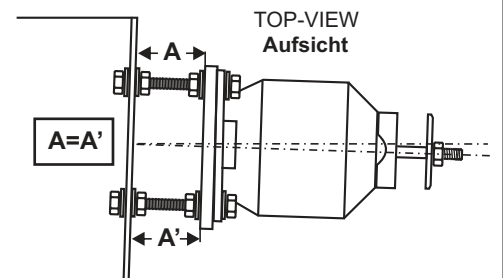

! Engine thrust on balk head is already adjust at factory

Sturz und Zug beachten!

20- Li-Po battery stand

Magnetic battery hatch

1

Li-Po battery stand

2

Secure the Li-Po battery stand using four 2x10mm screws

3

 In case of brushless motor using.

4

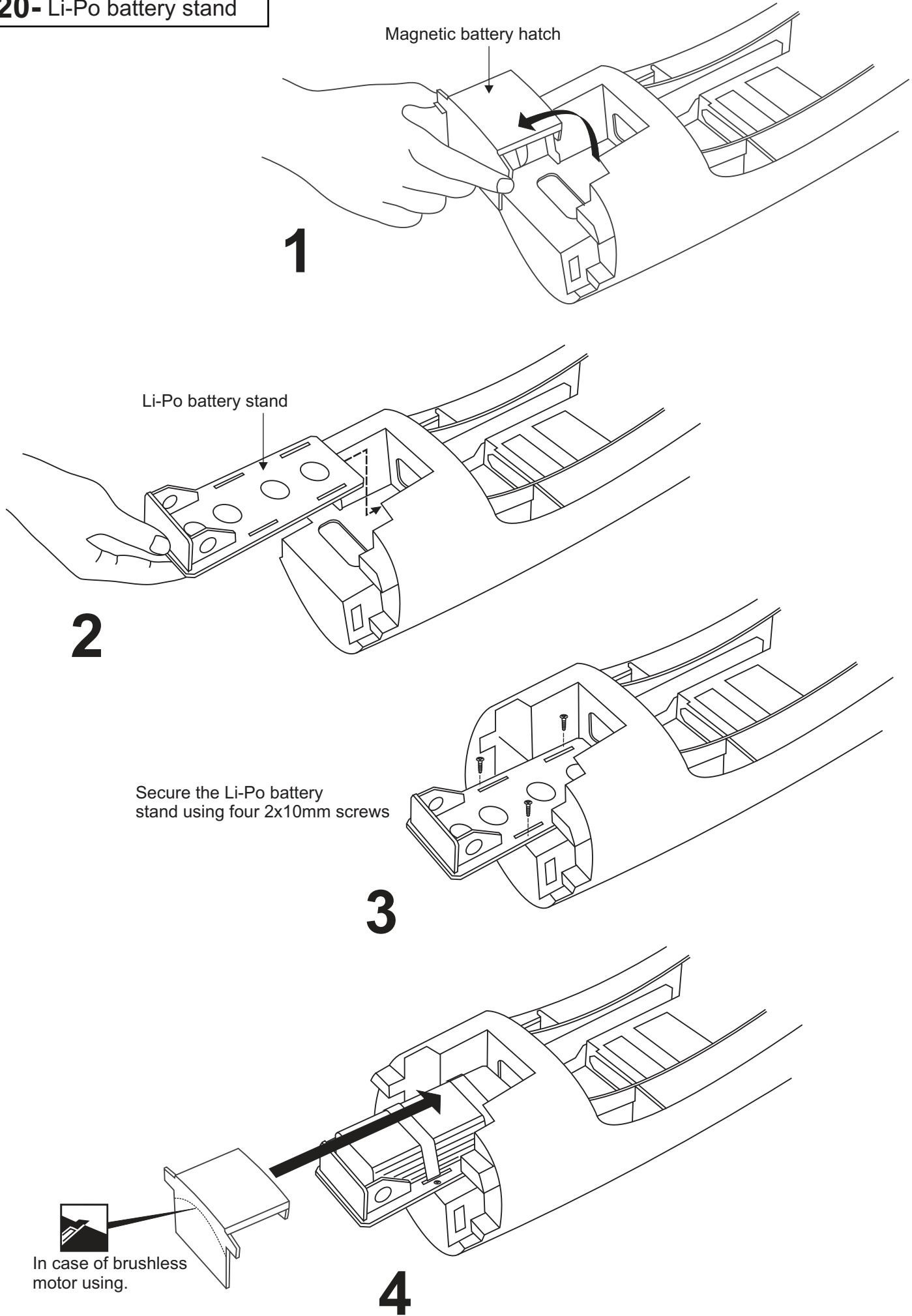

21- Servo installation

FUSELAGE BOTTOM-VIEW
UNTERSICHT

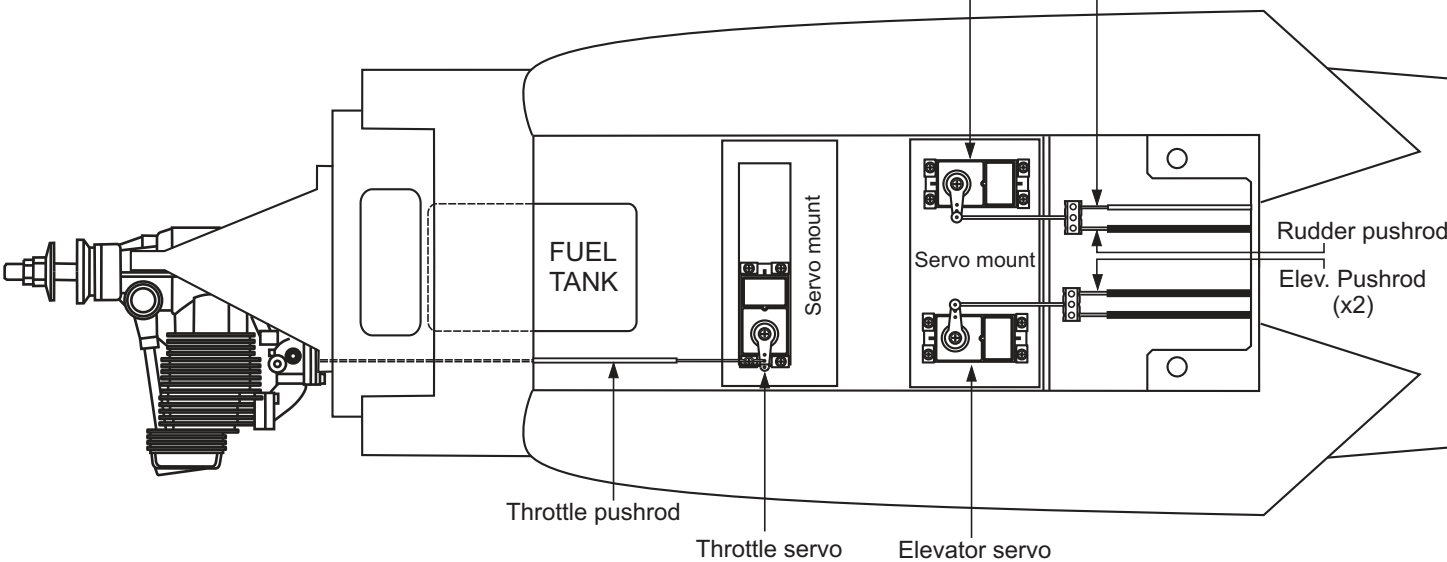

Connector

	2
	3

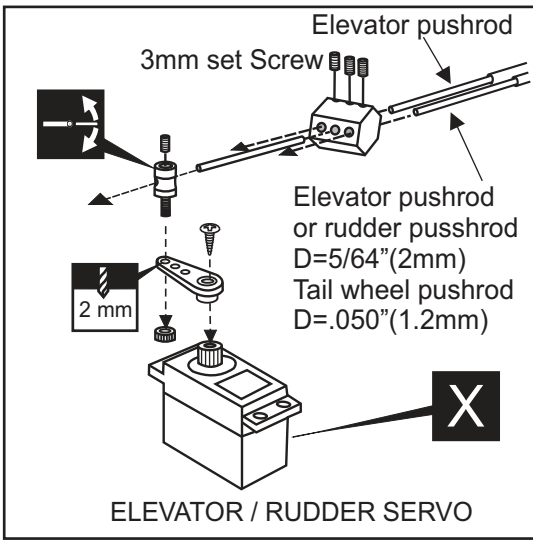
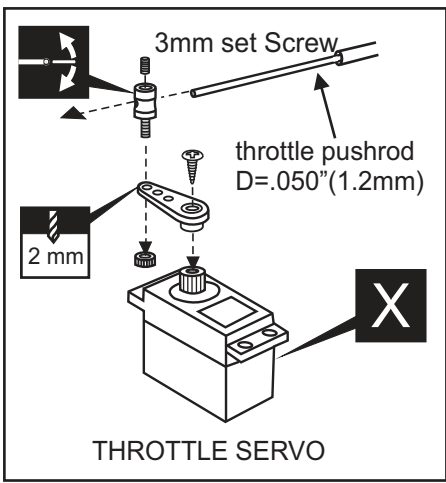

22- Linkages / Alenkung

FUSELAGE BOTTOM-VIEW
UNTERSICHT

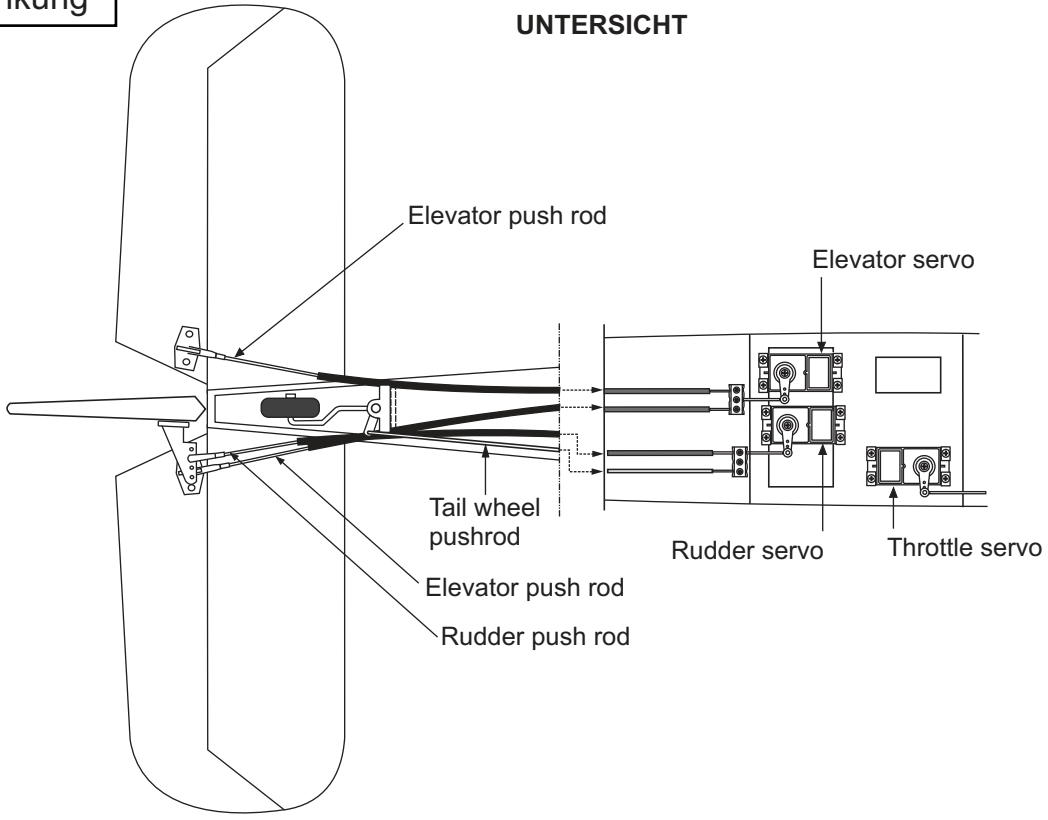

23- Cowling / Motorhaube

3/32x25/64" self tapping screw
2.5x10mm

5

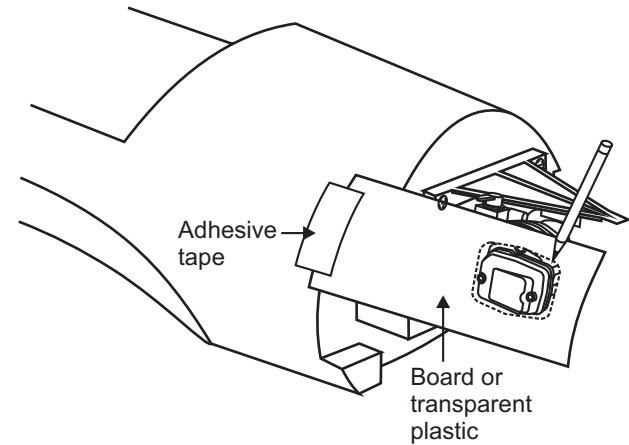

1-Attach the board or transparent plastic on the side of the fuselage with the adhesive tape as show.

2-Using a pencil or felt tipped pen trace around the engine head where it meet the cowl. Cut the opening the board or transparent plastic for the engine head as marked before.

3-Remove the engine and insert the cowl on to the fuselage so the distance from the fire wall to the front of the cowl is 123 ~ 126mm. Trace around inside the hole on the board or transparent plastic with a pencil.

4-Remove the cowl from the fuselage and carefully cut the opening for the engine head as marked above. Do the same way with the hole for needle-valve.

5-Again. Insert the cowl on to the fuselage and secure it in place with five 2.5x10mm self tapping screws.

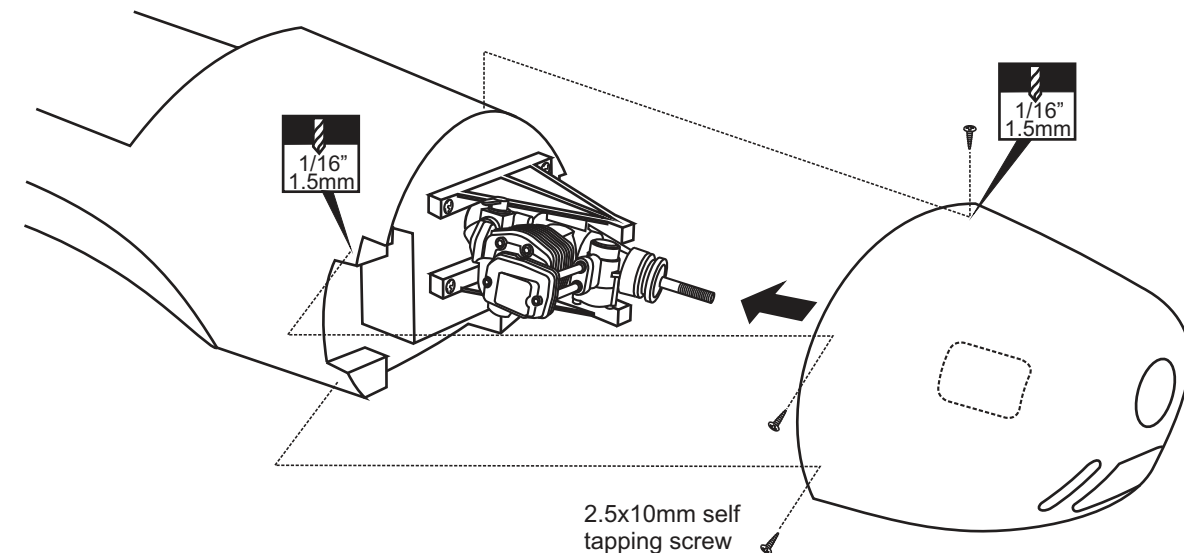
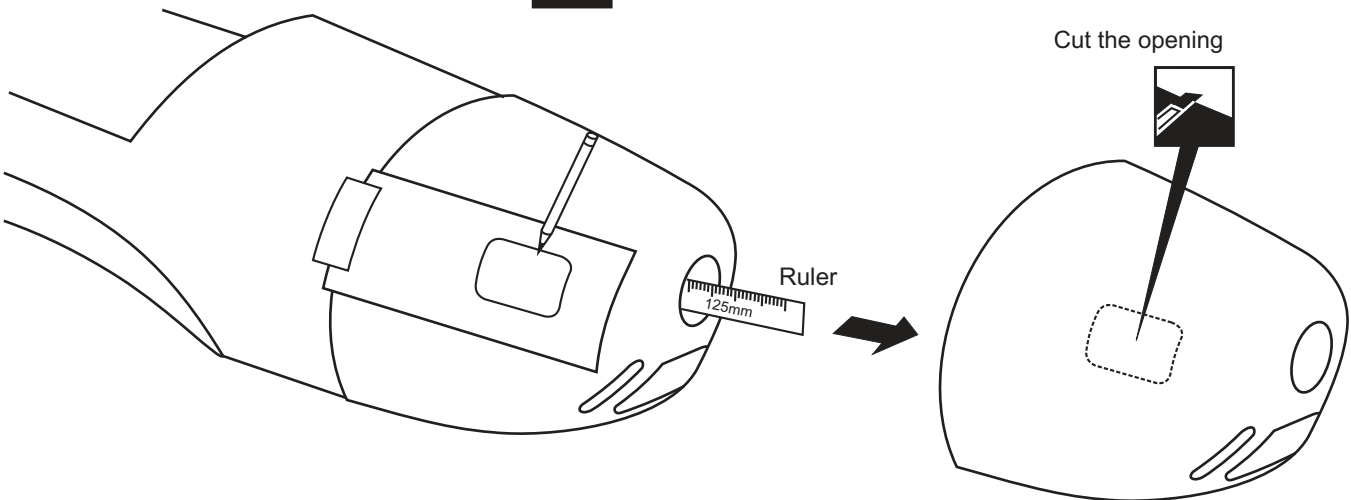
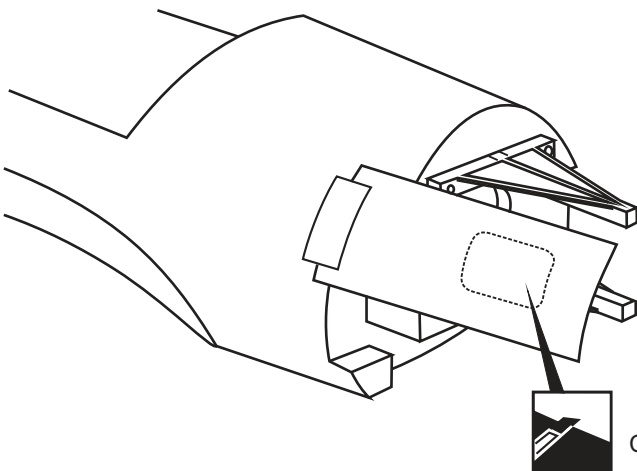

24- Canopy / Kabinenhaube

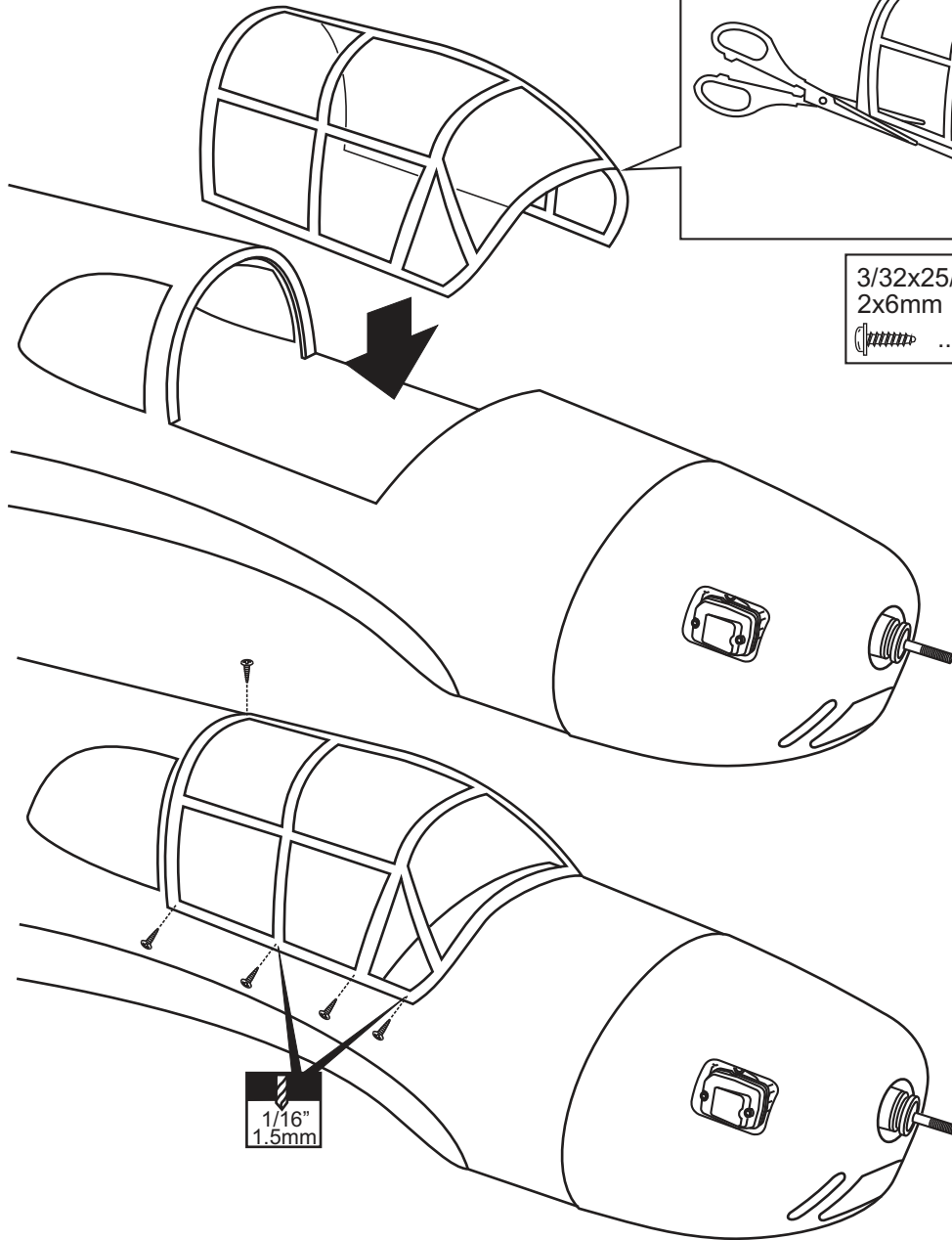

3/32x25/64" self tapping screw
2x6mm

.....10

1/16"
1.5mm

25- ABS Shield

Vis 2x10mm

.....6

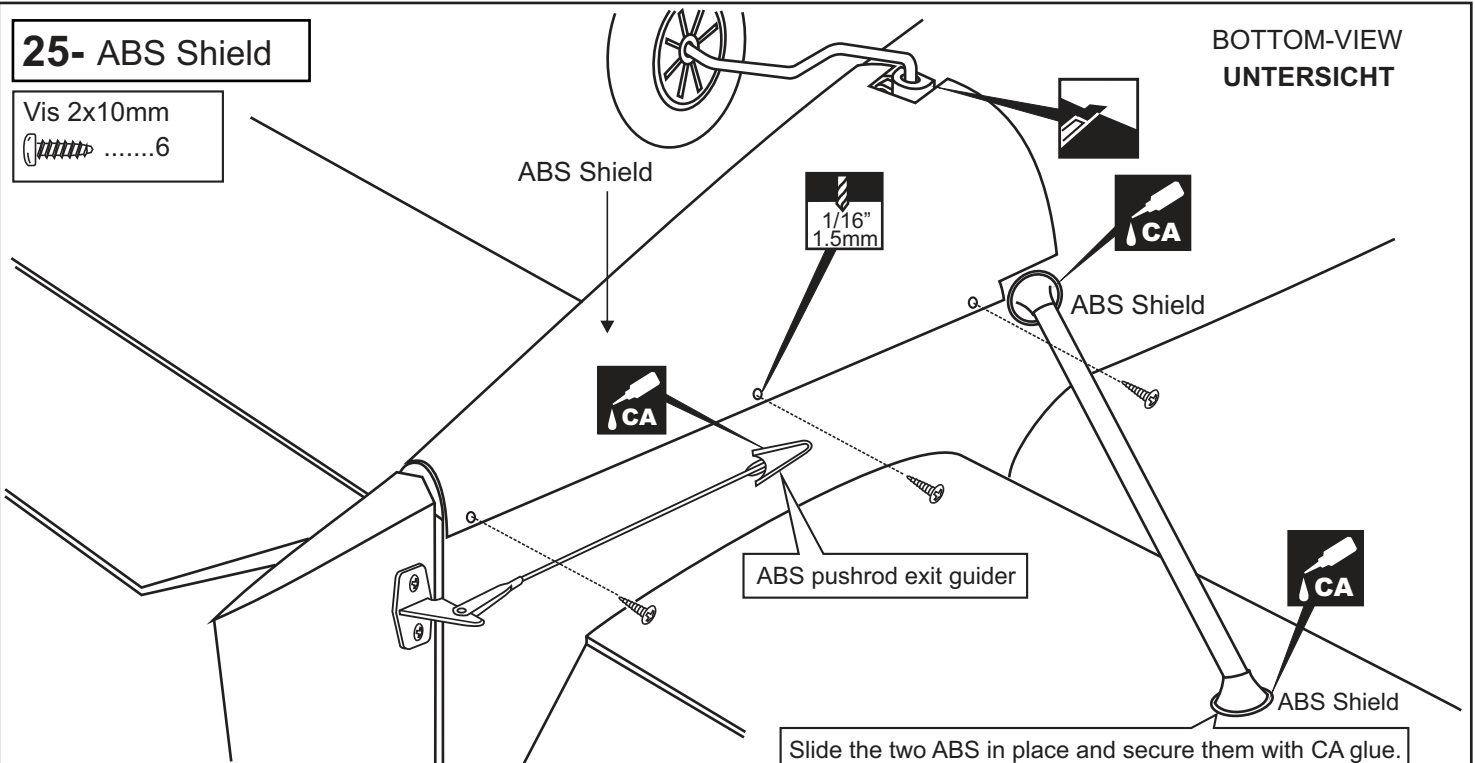

BOTTOM-VIEW
UNTERSICHT

ABS Shield

1/16"
1.5mm

ABS Shield

ABS pushrod exit guider

ABS Shield

Slide the two ABS in place and secure them with CA glue.

26- Wing installation

BOTTOM-VIEW
UNTERSICHT

6x50mm
Nylon bolt



6x50mm Nylon bolt



....2

27- Balance / Schwerpunkt

Note: Adjust the location of the battery pack to achieve this C.G location.

DO NOT try to fly an out-of balance model!

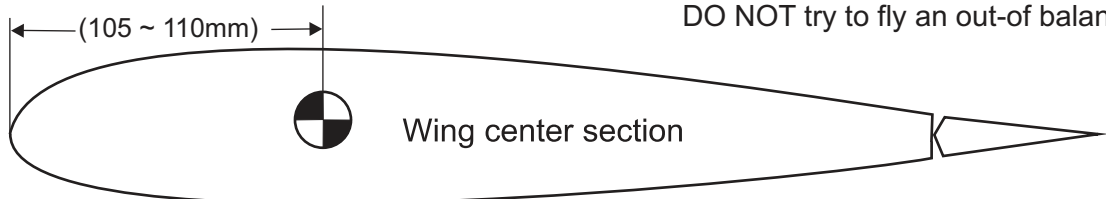

28- Control surface / Ruderausschläge

Do not try to fly an out-of balance model!

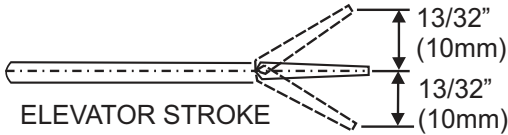

ELEVATOR STROKE

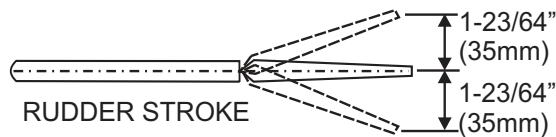

RUDDER STROKE

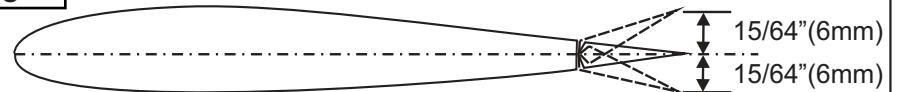

AILERON STROKE

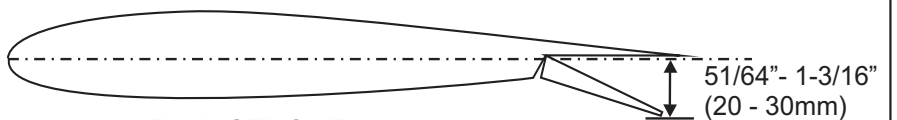

FLAP STROKE

Adjust the travel of the control surfaces to achieve the values stated in the diagrams. These values will be suitable for average flight requirements. Adjust the values to suit your particular needs.

29- Decor / Aufkleber

IMPORTANT: Please do not clean your model with pure alcohol, only use liquid soap with water or use class cleaner to clean on surface of your model to keep the colour not fade.

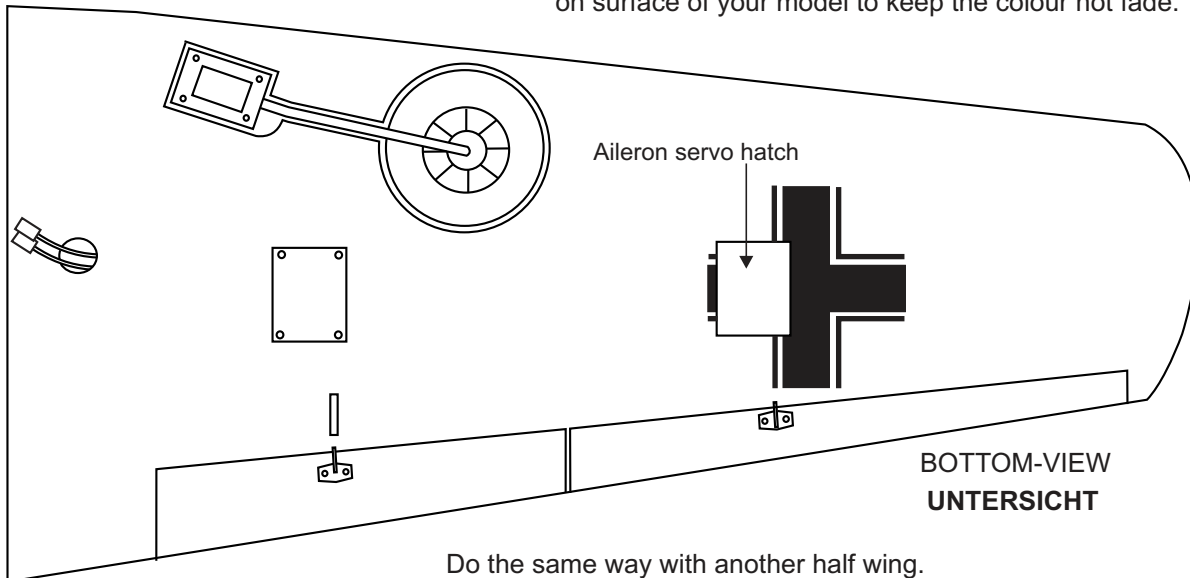

BOTTOM-VIEW
UNTERSICHT

Do the same way with another half wing.



1 Sticker

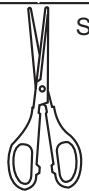

2

Aileron servo hatch