

1. Fit P1 into the slots in FW.
Slide P2 into P1 and FW.
Glue P1, P2 and FW
together.

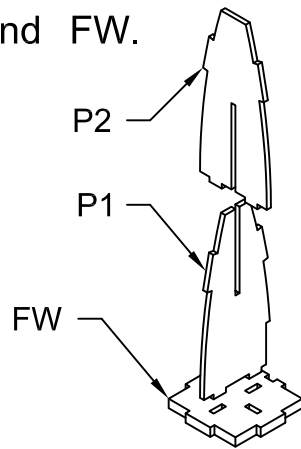

2. Secure the motor mount to the
firewall FW. Use the etched lines
for proper motor mount alignment.

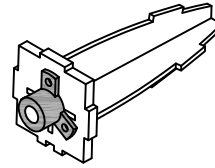

3. Fit and glue P3 to the motor mount
assembly. Ensure that the notched tab in
FW is fit into the slot in P3.

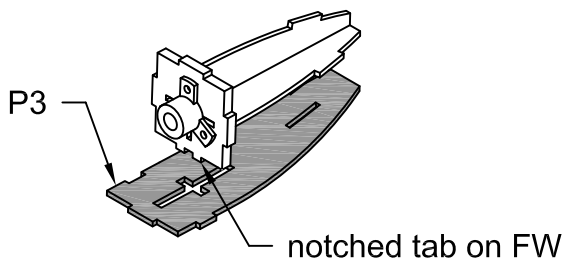

4. Fit and glue P4 to the motor mount
assembly.

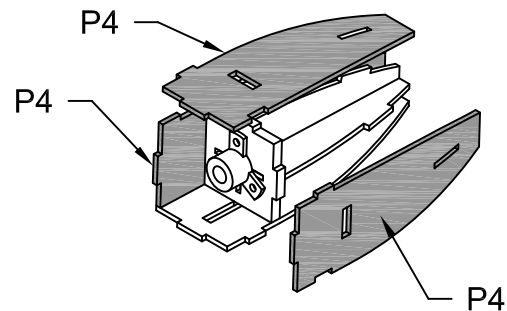

5. Drill a small hole(s) in the pod sides
to allow access to the motor set screw
in the motor mount. Fit and glue P5
in place.

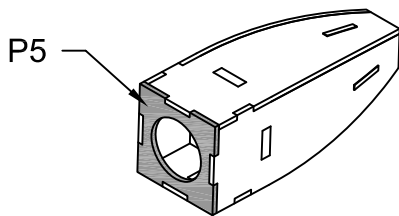

6. Fit and glue P6 in place. Sand the
motor pod, rounding edges as desired.

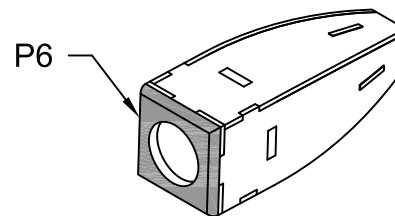

7. Fit and glue MP2 into MP1. Sand the
leading and trailing edges as desired.

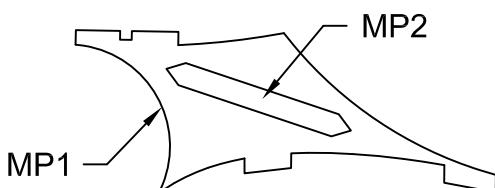

8. Fit and glue the
motor pylon to the
motor pod.

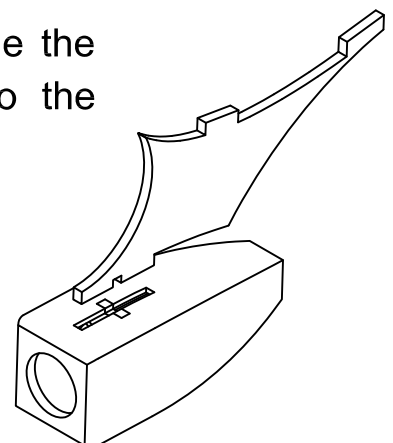

9. Fit and glue the wing panels W1 and W2 together.

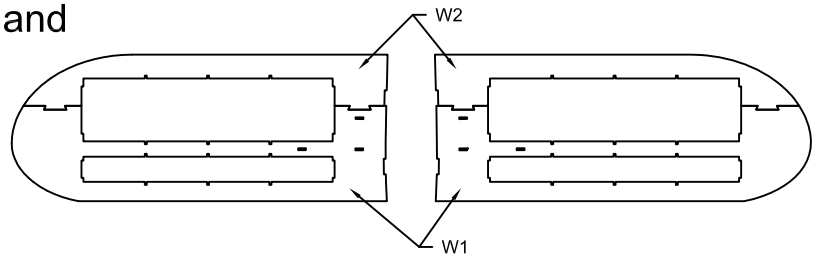

10. Fit and glue ribs R2-R5 to the wing panels. It is recommended to start by gluing the ribs to the trailing edge first, then the center and finally the leading edge. Make sure the ribs are fully seated into the notches in the trailing edge before gluing in place. Be sure to build a right and left wing panel.

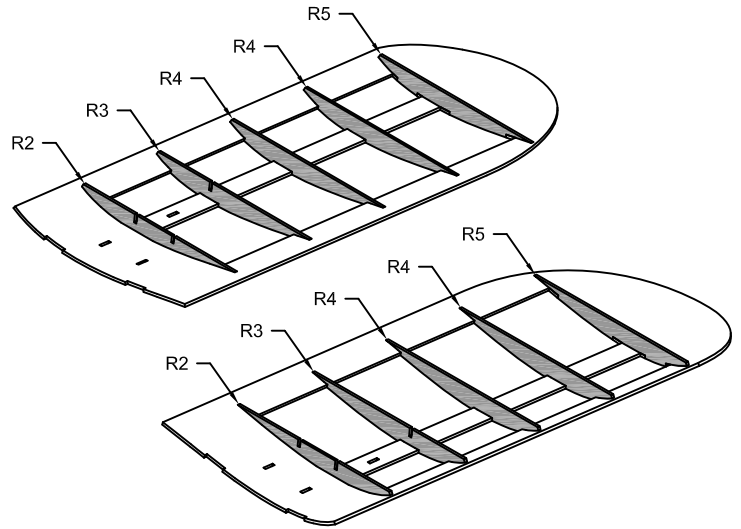

11. Fit WS1 and WS2 into the slots in R1.

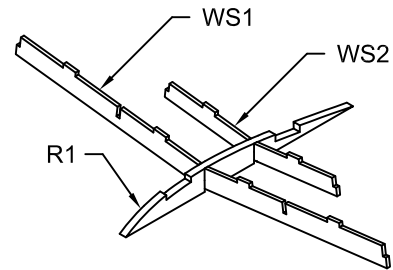

12. Fit and glue the wing spar assembly into the slots in R2, R3 and the wing panel. Do not glue R1 to the wing panel yet.

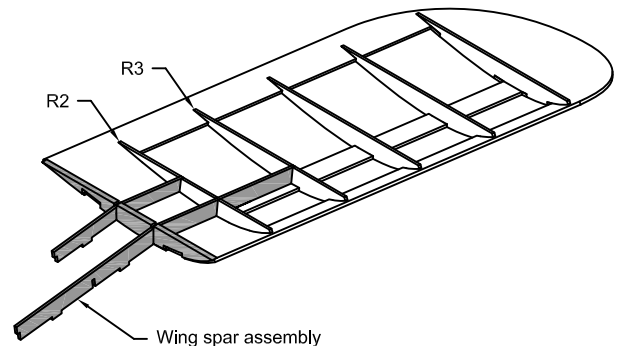

13. Fit and glue the second wing panel and wing spar assembly together. Make sure the leading and trailing edges of both wing panels are aligned and glue R1 to both wing panels.

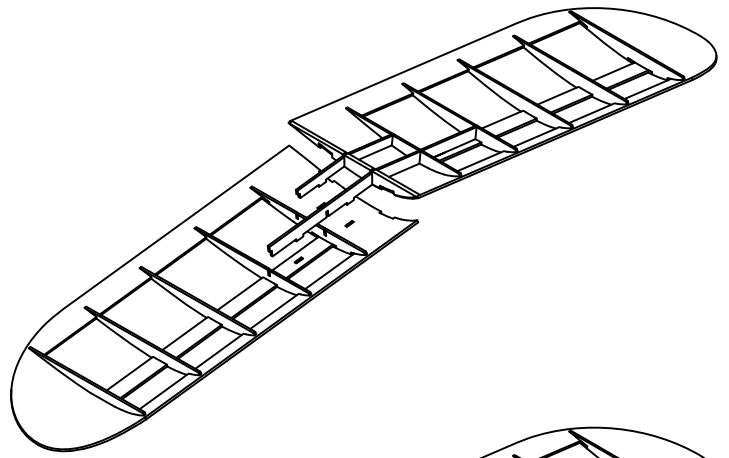

14. Fit and glue the leading edge strips LE to the leading edge of the wing panels.

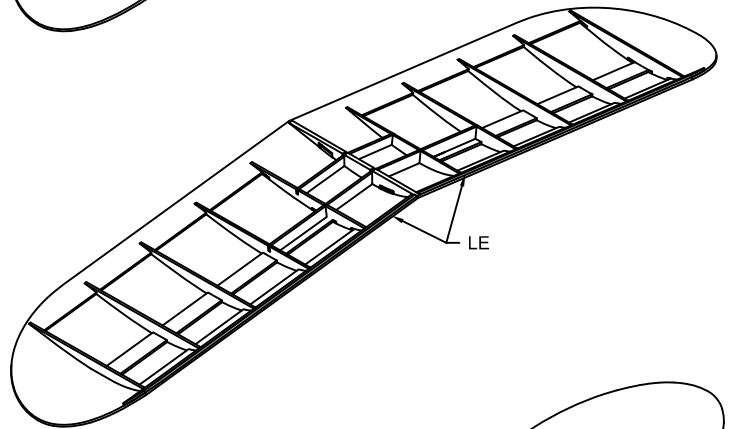

15. Sand the wing, rounding over the leading edge. Cover the wing, bottom first and then the top.

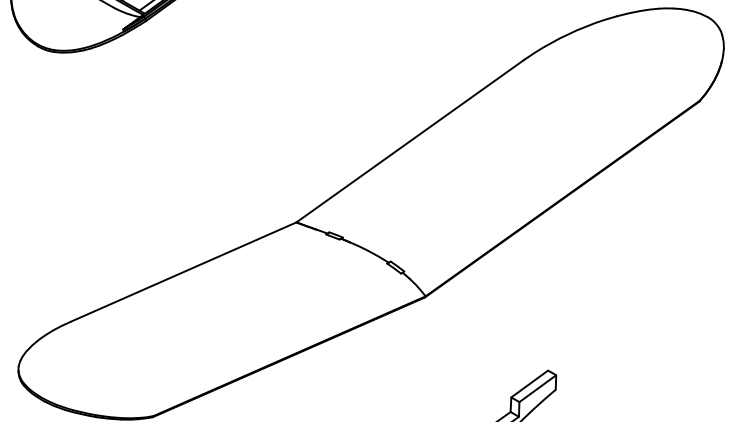

16. Cut a hole in the bottom of the pod large enough to pass the motor wires through.

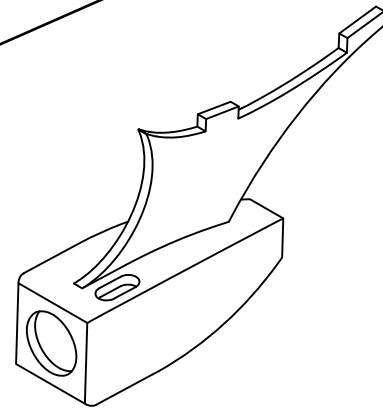

17. Trim away the covering on the top of the wing as necessary for a good glue joint and glue the motor pod to the wing using epoxy. Cut a hole in the wing large enough to pass the motor wires through.

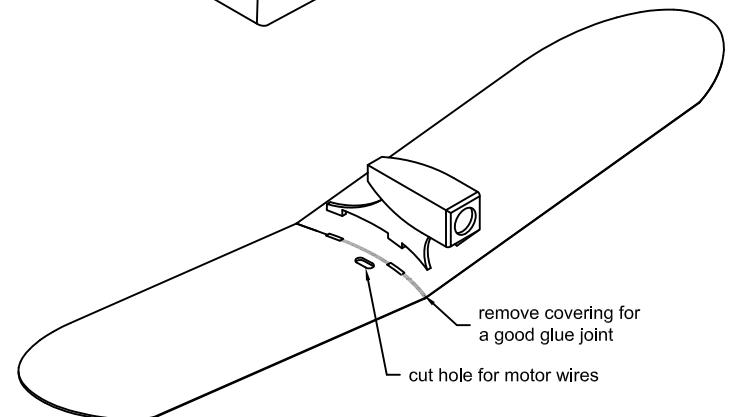

18. Fit and glue V10 into V9 as shown.

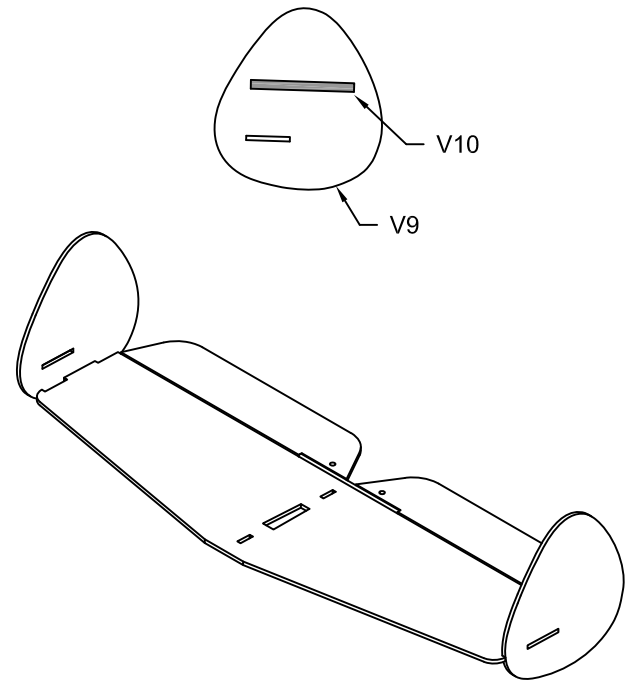

19. Cover and assemble the horizontal stabilizer assembly. Join the elevator halves with a 2" piece of the included CF rod.

20. Glue $\frac{1}{8}$ " magnet into BH4.

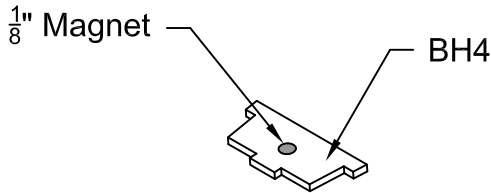

21. Align the back edge of BH1 and BH2 and glue together. Glue BH3 to BH2. Glue $\frac{1}{8}$ " magnet into BH2.

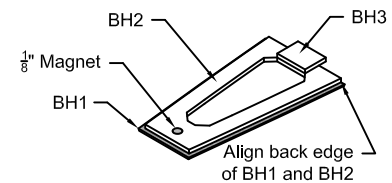

22. Glue ply rubber band hook to F3.

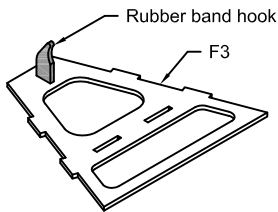

23. Install servos into servo tray.

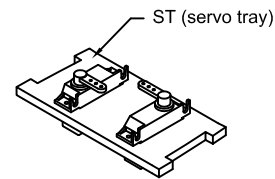

24. Fit and glue F1 and F3 to BT.

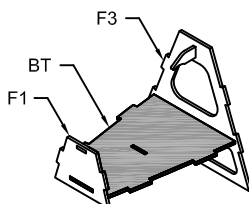

25. Fit and glue BH4 to F1, ensure the magnet is oriented to match the polarity of the battery hatch. Fit and glue F2 to BT.

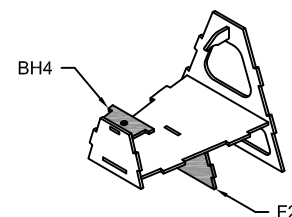

26. Fit formers F1-F6, Battery Tray (BT) and servo tray (ST) into fuselage side FR. Be sure to orient the servo tray so that it tapers towards the rear. Do not glue anything in place yet.

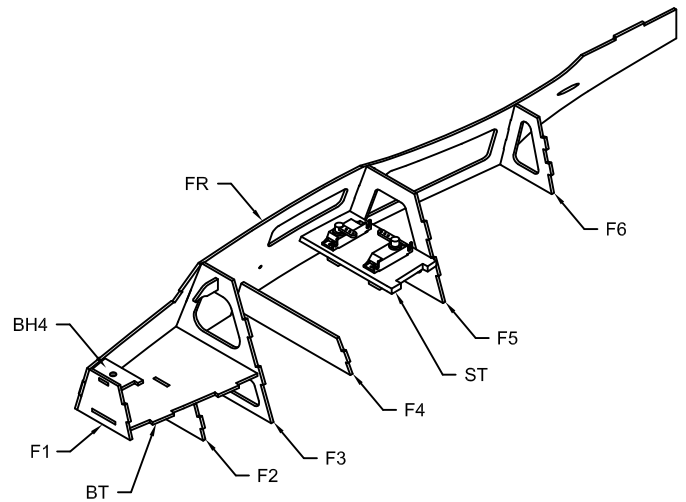

27. Fit fuselage side FL to formers F1-F6, Battery Tray (BT) and servo tray (ST). Ensure all parts are fully seated into their slots and glue together in the following order:

- BT to fuselage sides
- F3 to fuselage sides
- F2 to fuselage sides
- F1/BH4 to fuselage sides
- F4 to fuselage sides
- ST/F5 to fuselage sides
- F6 to fuselage sides

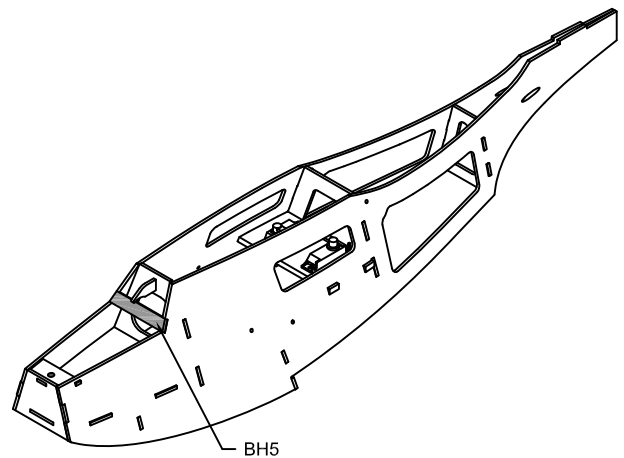

Fit and glue BH5 to fuselage sides.

28. Temporarily fit the horizontal stabilizer to the fuselage. Adjust the fuselage ends so that the horizontal stabilizer is properly aligned with the fuselage. When satisfied with the alignment, tack glue the fuselage ends together. Remove the horizontal stabilizer assembly and fully glue the fuselage ends together.

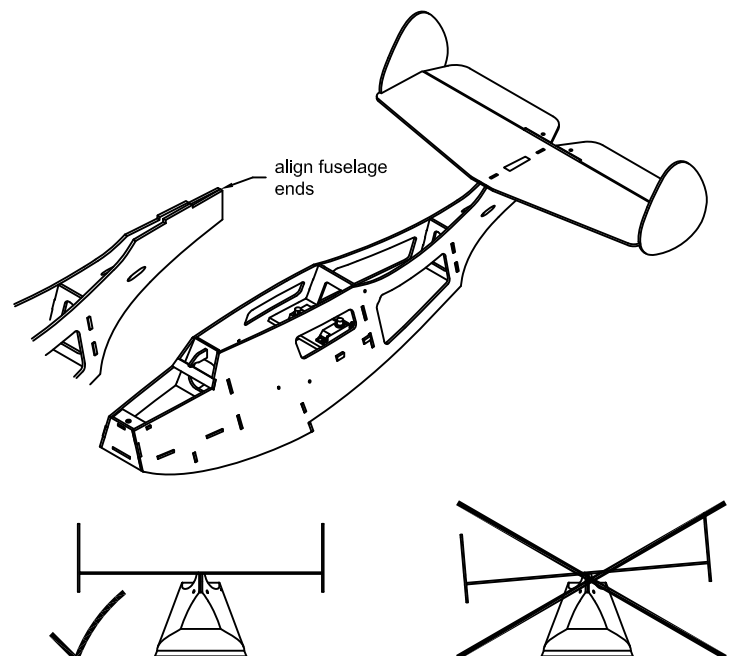

29. Fit and glue the $\frac{1}{32}$ " balsa sheeting together.

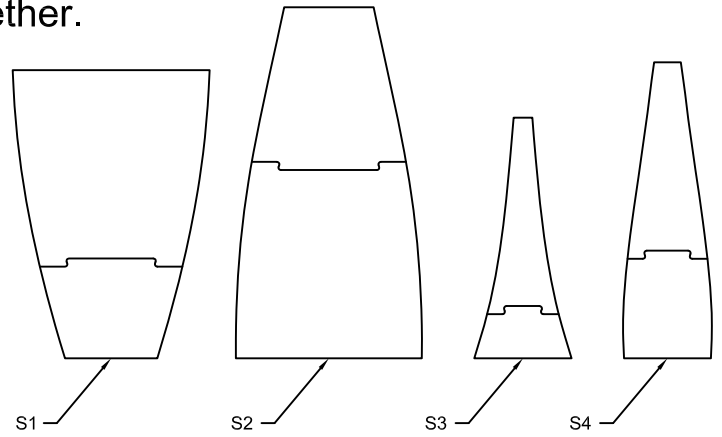

30. Use a sanding bar to sand the bottom of the fuselage sides and formers. Glue sheeting S3 to the fuselage bottom first, allow sheeting to overlap all edges.

Sand S3 flush with the bottom of the fuselage at former F6. Glue sheeting S2 to the bottom of the fuselage.

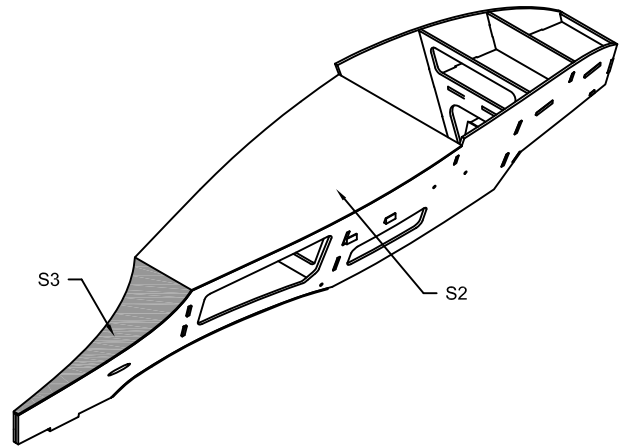

31. Glue F4A to the fuselage sides and the sheeting S2.

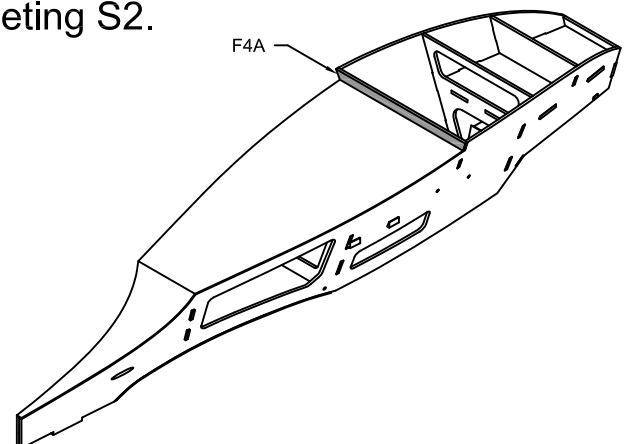

32. Sand F4A flush with the bottom of the fuselage. Glue sheeting S1 to the bottom of the fuselage.

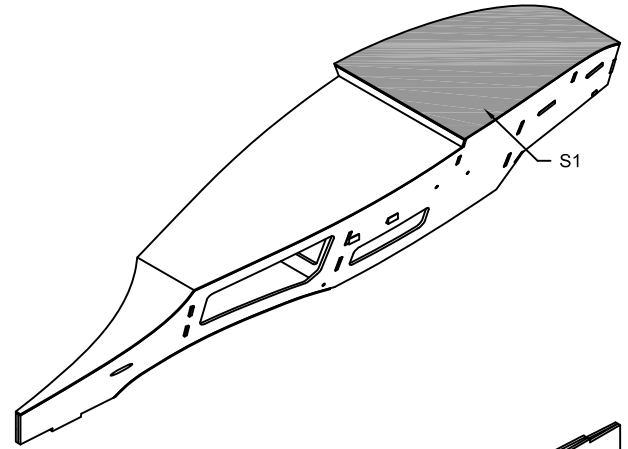

33. Sand the top of the fuselage. Glue sheeting S4 to the fuselage.

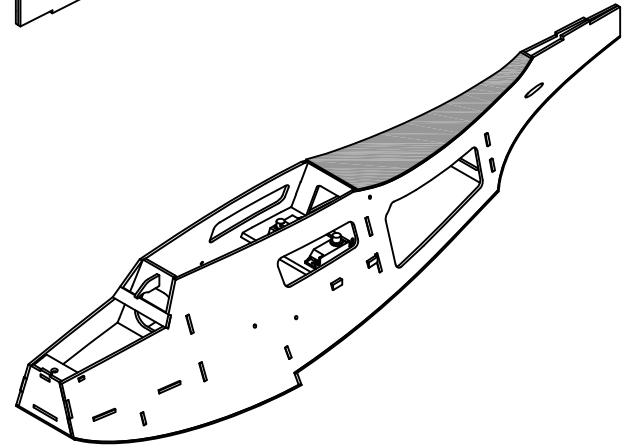

34. Sand the fuselage sides flush with the face of former F1. Stack and glue the $\frac{1}{4}$ " balsa nose blocks to F1. Glue S5 in place.

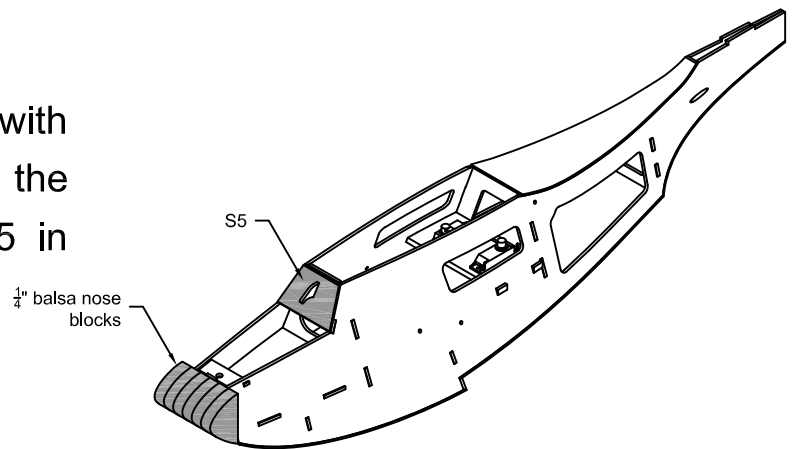

35. Sand the fuselage sides. Check the fit of the battery hatch, sand as necessary for a good fit.

It is recommended to waterproof the inside of the fuselage prior to covering if you intend to fly your Mini Drake off the water.

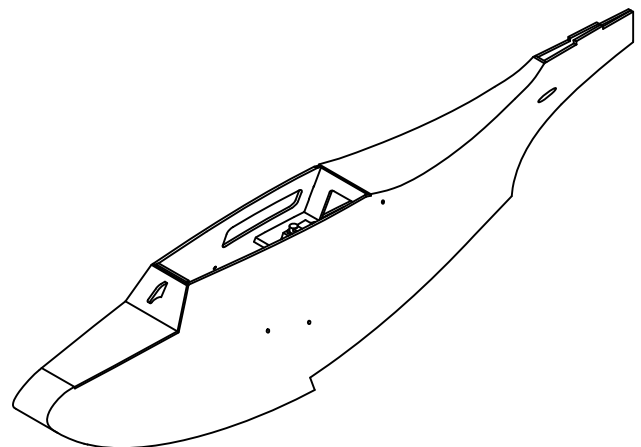

36. Cover/finish the fuselage.

37. Make two (2) sponsons by gluing the sponson sheeting S1A and S1B together. Fit and glue S2 and sponson sides in place as shown in Fig.1. Bend and glue the sheeting around the sponson sides as shown in Fig.2. Lightly wet the outside of the sheeting if necessary to help bend .

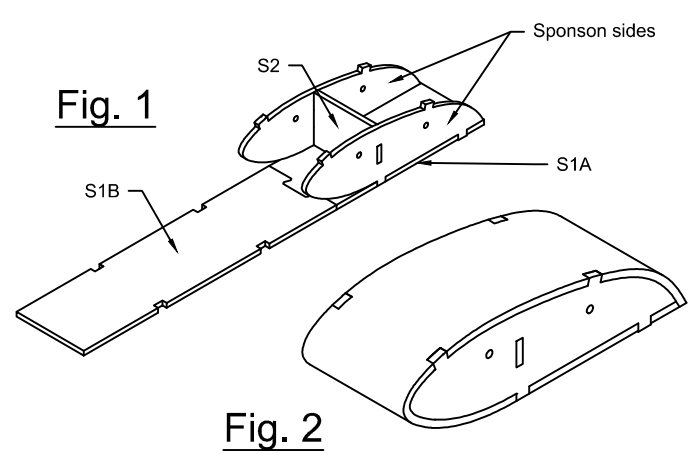

38. Cut two (2) pieces of CF rod 9-1/2" (24.1cm) long and slide through holes in the fuselage. Fit sponsons onto the CF rods and glue in place. Equally space sponsons from fuselage and glue CF rods to the fuselage. Cut a 2-1/2" (6.4cm) length of CF rod, slide into holes in fuselage and glue in place.

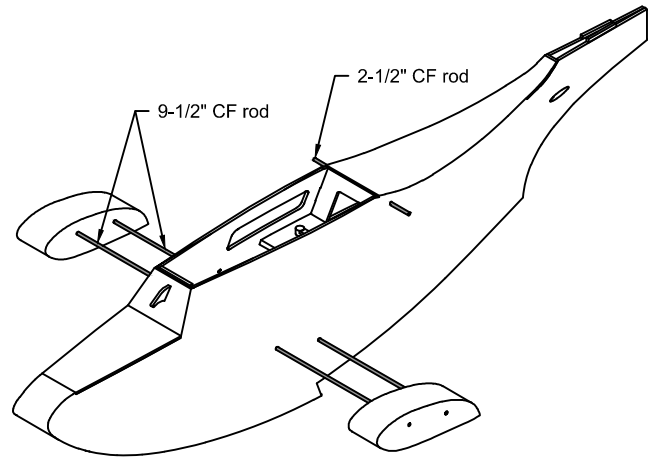

39. Fit end glue the horizontal stabilizer assembly to the fuselage.

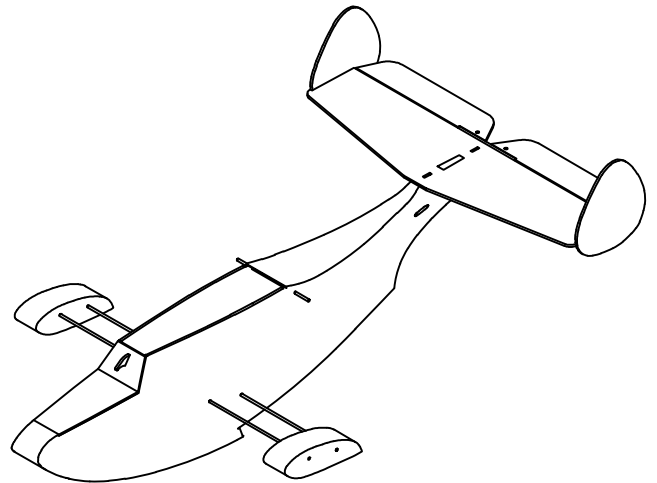

40. Fit end glue the vertical stabilizer to the fuselage. Attach the rudder to the vertical stabilizer.

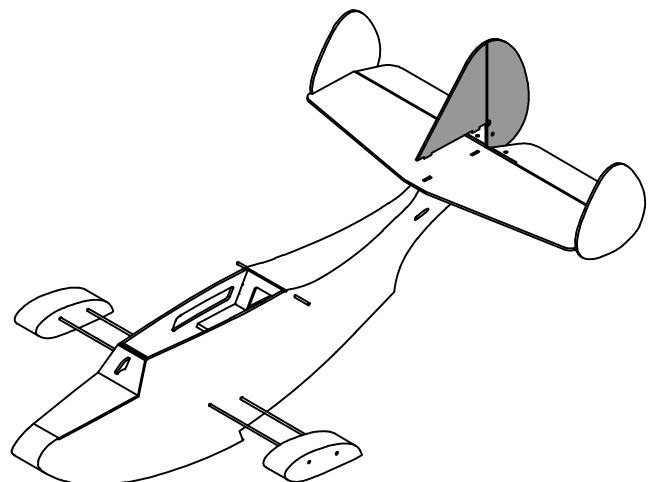

41. Glue the vertical stabilizer sub fin to the bottom of the fuselage.

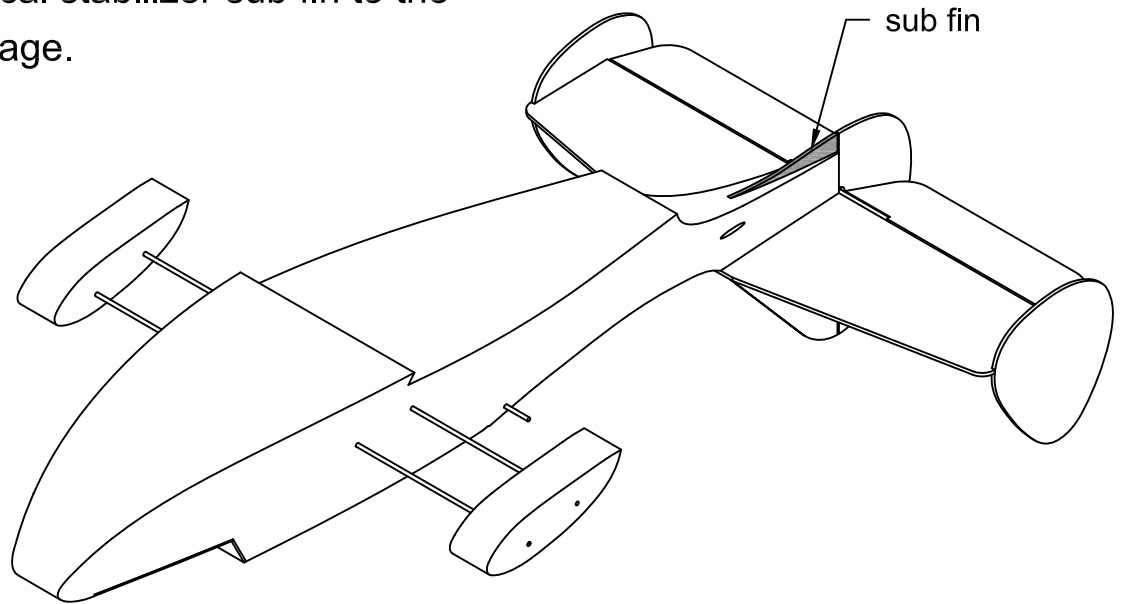

Final Assembly and Flying

1. Attach control surfaces (elevator, rudder) to flying surfaces with clear packing tape, covering material or similar. Install pin style controls horns in the precut holes in the elevator and rudder.

2. Install motor, route wires through the pod and wing and connect motor leads to the ESC (Electronic Speed Control). Connect servos and ESC to the receiver and place the receiver right behind former F3. Route battery lead into the battery compartment and secure wing to fuselage using two (2) rubber bands.

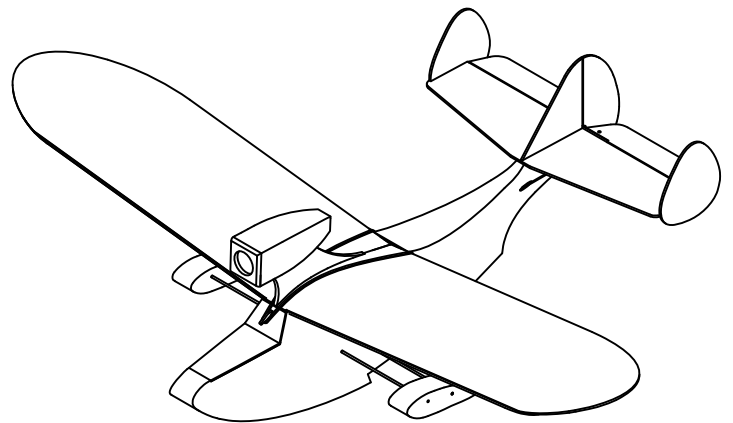

3. Place battery into battery compartment, use velcro to secure battery in place.

4. Set the throws for the control surfaces:

- Elevator - 1/4" up/down
- Rudder - 3/8" left/right

5. Balance the Mini Drake on the main spar WS1, shift battery as necessary to obtain proper balance.