

Section F-F

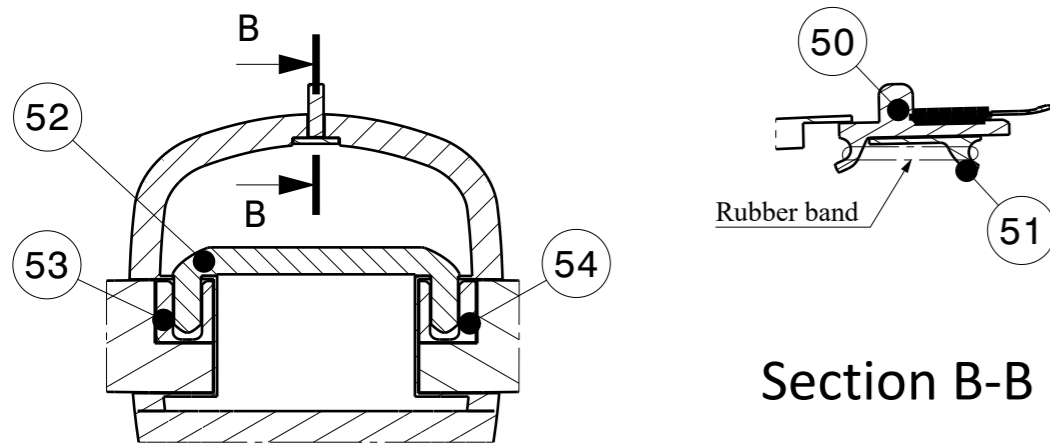

Section B-B

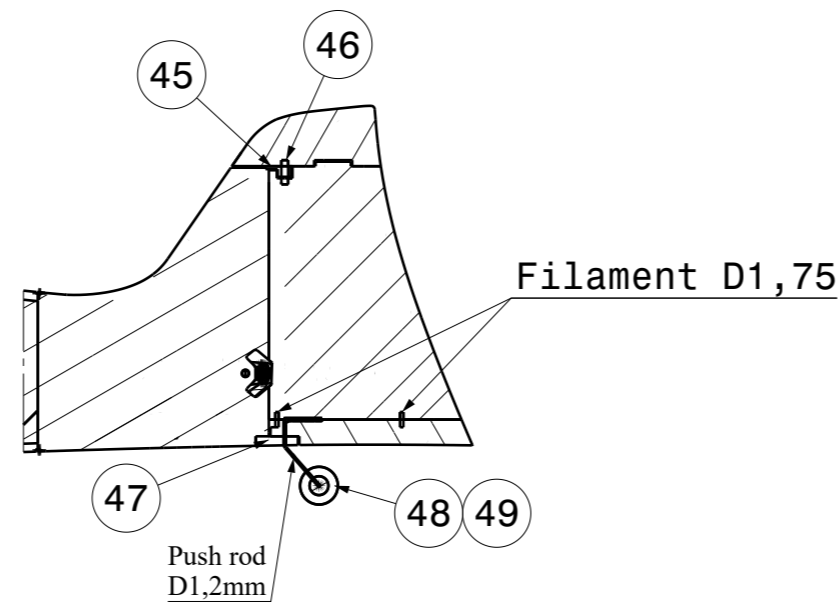

Section D-D

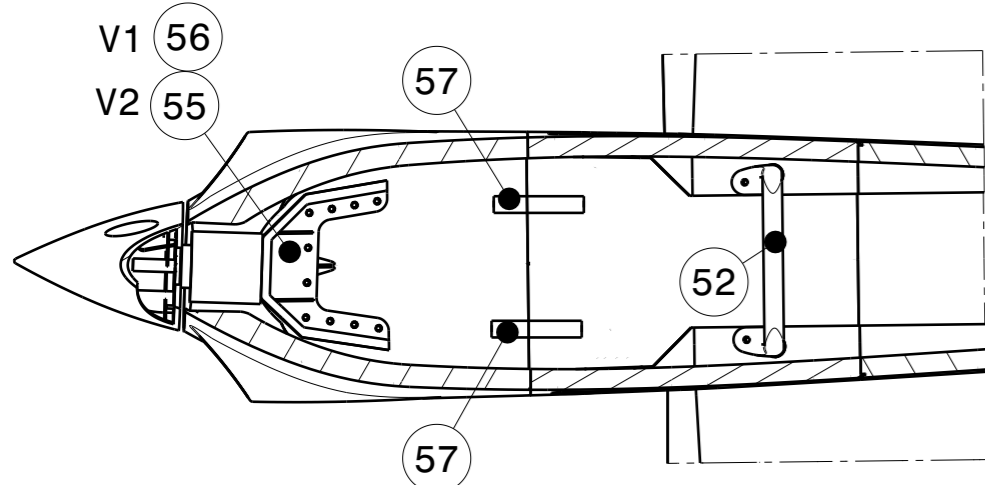

Section E-E

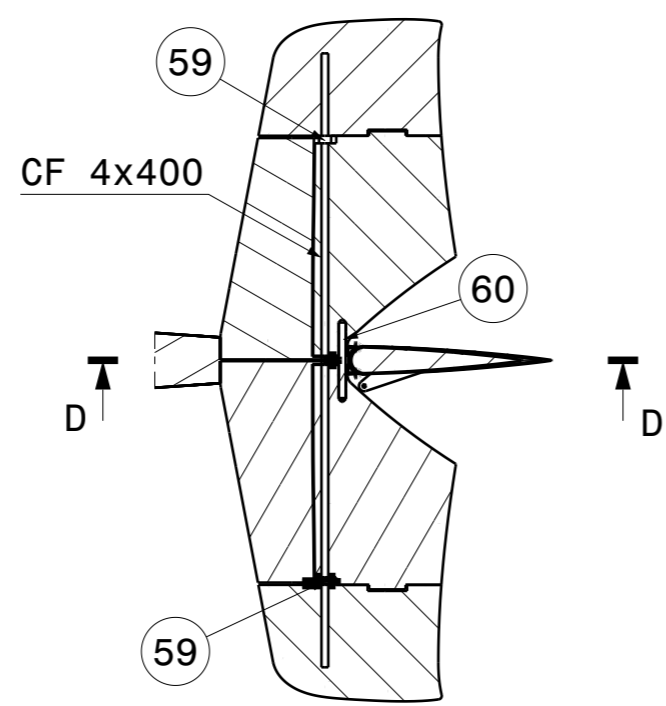

Section C-C

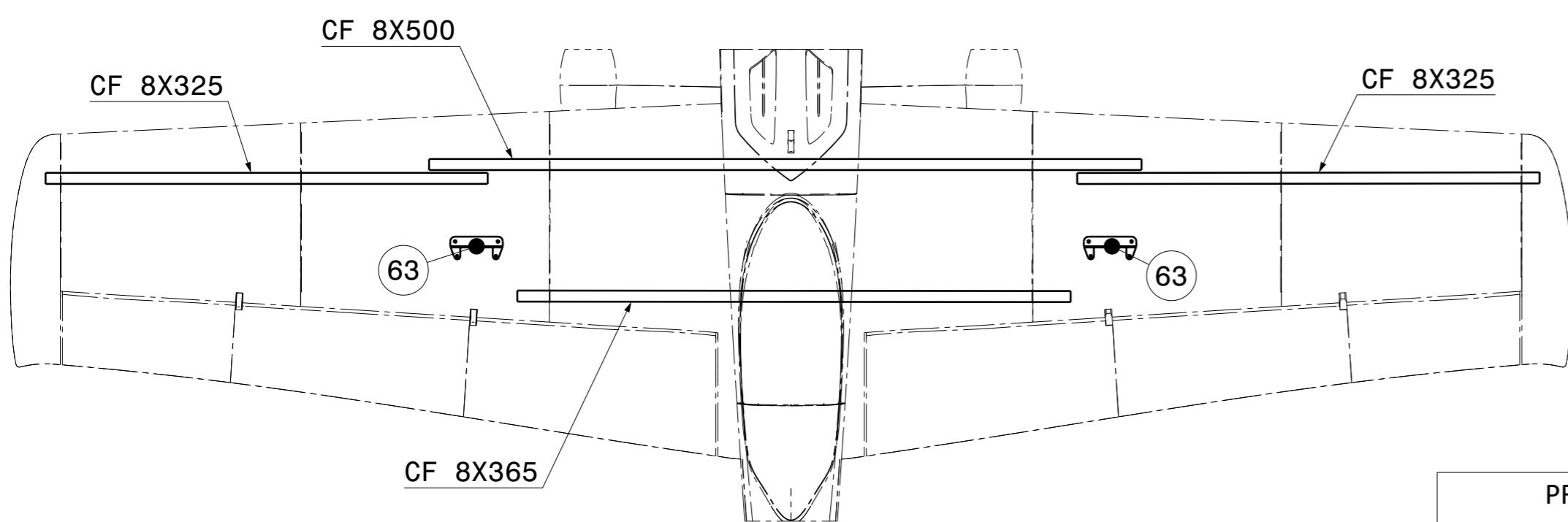

ITEM	NAME	CATEGORY
1	Spinner1	C
2	Spinner2_D6	C
3	Fus1	A
4	Fus2	A
5	Fus3	A-LW
6	Fus4	A-LW
7	Fus5	A-LW
8	Fus6	A-LW
9	Rudder_3	A-LW
10	Rudder_2	A-LW
11	Rudder_1	A-LW
12	Wing1L	A-LW
13	Wing1R	A-LW
14	Wing2L	A-LW
15	Wing2R	A-LW
16	Wing3L	A-LW
17	Wing3R	A-LW
18	Wing4L	A-LW
19	Wing4R	A-LW
20	Aileron1L	A-LW
21	Aileron1R	A-LW
22	Aileron2L	A-LW
23	Aileron2R	A-LW
24	Aileron3L	A-LW
25	Aileron3R	A-LW
x2	26 Hinge_wing_1	C
x2	27 Hinge_wing_2	C
28	Canopy1	A-LW
29	Canopy2	A-LW
30	HTP1L	A-LW
31	HTP1R	A-LW
32	Elev1L	A-LW
33	Elev1R	A-LW
34	Elev2L	A-LW
35	Elev2R	A-LW
36	LG_L	C
37	LG_R	C
x2	38 Wheel_fairing_front	A-LW
x2	39 Wheel_fairing_rear	A-LW
40	Air_plate2L	C
41	Air_plate2R	C
x2	42 Tyre_D50	C
x2	43 RimD50	C
x2	44 Servo_holder_fus	C
45	Rudder_hinge_top	C
x9	46 Axis	C
47	Rudder_fitting	C
3	48 TyreD25	C
49	RimD25	C
50	Lock_2	C
51	Lock_1	C
52	Central_strut	C
53	LG_pin_box_L	C
54	LG_pin_box_R	C
4	55 Motor_holder_D35	C
4	56 Motor_holder_D28	C
x2	57 Battery_strap_fitting	C
58	Spinner2_D5	C
x2	59 Elev_hinge	C
60	Elevator_fitting	C
61	Air_plate1L	C
62	Air_plate1R	C
x2	63 Servo_holder_wing	C
64	Spinner1_short	C

PRINTING PARAMETER	CATEGORY		
	A-LW	A	C
Layer height (mm)	0.25	0,2	0,13
Bottom layers	0	0	4
Top layers	0	0	6
Wall lines / perimeter	1	1	2
Nozzle diameter (mm)	0,4	0,4	0,4
Material	LW-PLA	PLA/ PETG	PLA/PETG FLEX/ABS
Infill density (%)	0	0	10
Printing temp (°C)	235	220	205 to 240
Bed temp (°C)	60	60	60
Flow (%)	53	100	100
Retraction (mm)	0,5 to 3	0,5 to 3	3
Retraction extra prime amount (mm)	0	0 to 0,7	0
Speed (mm/s)	55	50	25 to 50
Fan	YES	YES	YES
Brim (mm)	3 to 5	3 to 5	0 to 3
Minimum layer time (s)	5	5	5
Support	NO	NO	NO

2T Add 2 top layers

8B Add 8 bottom layers

2B Add 2 bottom layers

4 If your motor reach temperatures over 50 °C use ABS or PETG

3 Print it with flexible material

2-Center of gravity marking under the wing

1- Red parameters are mandatory to ensure airplane functionality, assembly or weight target.