

# User Guide

rev. 2023/05



Fully 3d printable

## North American P-51D Mustang

scale 1:8, wingspan 1.4m / 55.5 inch

## North American P-51D Mustang fully printable R/C plane for your desktop 3Dprinter

Fully 3D printable RC model of the classic plane, designed in 100% vase mode (retraction free) for printing mainly with [PolyLight 1.0 LW-PLA](#) active foaming filament (some parts PolyAir, PETg and flex), that allow printed planes to be lighter than any other RC plane building technique (1500g weight with wingspan 1.4m). Many scale details such as airframe plating Get ready for flying with this great performing flying legend!

**The first fully printable** airplane files prepared for your 3Dprinter, with flight characteristics, comparable or even superior to classic build model airplane. This is not a dream, now you can print this HI-TECH at home. Simply download and print the whole plane or spare parts anytime you need just for a cost of filament only about \$28.

**Extensive hi-tech 3d structural reinforcement** making the model very rigid while maintaining a lightweight airframe and exact airfoil even it's just a plastic. This perfect and exact 3d structure is possible only thanks to additive 3dprinting technology. So welcome to the 21st century of model flying and be the first at your airfield.

**Easy to assembly**, you don't need any extra tools or hardware, just glue printed parts together and make pushrods for control surfaces and bend 3mm wire for landing gear. The rest of the assembly is very easy. Simply add brushless motor, ESC, servos and radio system. Don't worry, detailed step by step PDF/VIDEO is included. You'll get a superb performing airplane with highly efficient powerplant capable of flying 7+ minutes at full throttle and speeds exceeding 80 kph. Low stall speed is achieved for easy landing on the other hand.

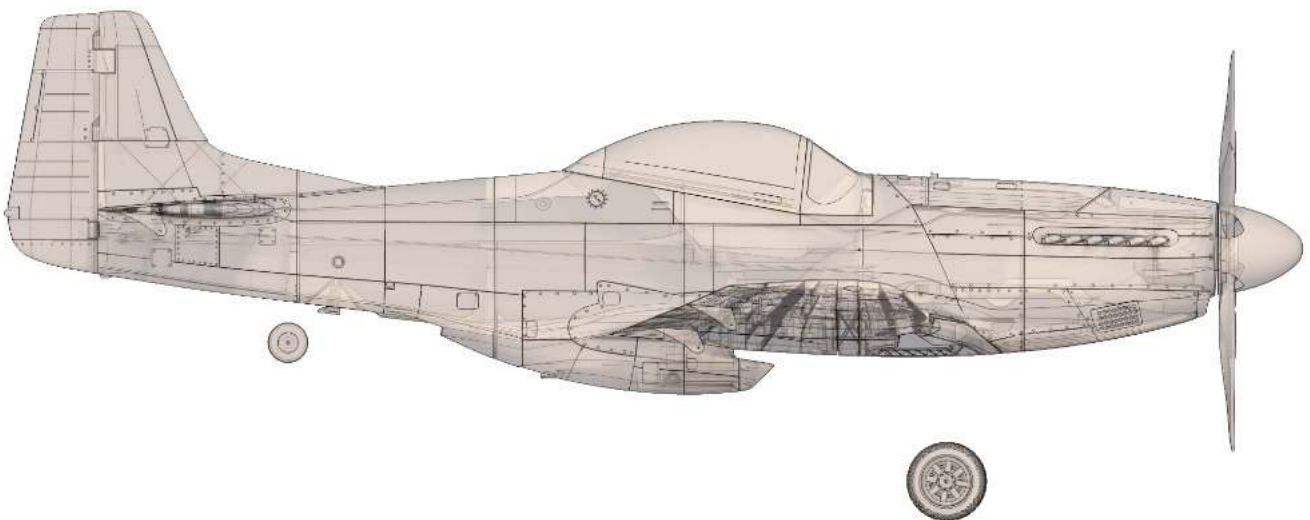

## General specifications:

Wingspan:	1395 mm / 55 inch
Length:	1220 mm / 48 inch
Height:	600 mm / 27 inch
Wing area:	40,7 dm <sup>2</sup> / 4.38 square feet
Wing loading:	34.7 g/dm <sup>2</sup>
Center of gravity:	100 mm / 3.9 inch from leading edge
Airfoil:	LHK508 modified by 3DLabPrint
Print weight (LW PLA):	776 g / 27.37 oz (including discs and tyres)
Empty weight (w/o battery):	1300 g / 45.86 oz
Takeoff weight (3s 2200 lipo):	1500 g / 52.91 oz
Never exceed speed, VNE:	160 km/h / 99 mph
Design maneuvering speed, VA:	80 km/h / 50 mph
Stall speed, VS:	20 km/h / 12 mph

## Recommended setup

Motor:	3542 1000KV (for 3S setup)
ESC:	40-50A/3S
Propeller:	two blade 12 x 6
Battery:	Li-Pol 2200mAh / 3S printed PETg motor mount

## Performance measurement

Max speed VH (level flight):	105 km/h – 56.7kn – 65.2mph
Rate of climb:	15 m/s (2 950 ft/min)
Flight time (3s 2200mAh)	6:30 min





## North American P-51D Mustang

The North American Aviation P-51 Mustang is an American long-range, single-seat [fighter](#) and [fighter-bomber](#) used during [World War II](#) and the [Korean War](#), among other conflicts. The Mustang was designed in April 1940 by a team headed by [James H. Kindelberger](#)<sup>15</sup> of [North American Aviation](#) (NAA) in response to a requirement of the [British Purchasing Commission](#). The commission approached NAA to build [Curtiss P-40 fighters](#) under license for the [Royal Air Force](#) (RAF). Rather than build an old design from another company, NAA proposed the design and production of a more modern fighter. The prototype NA-73X [airframe](#) was rolled out on 9 September 1940, 102 days after the contract was signed, and first flew on 26 October.

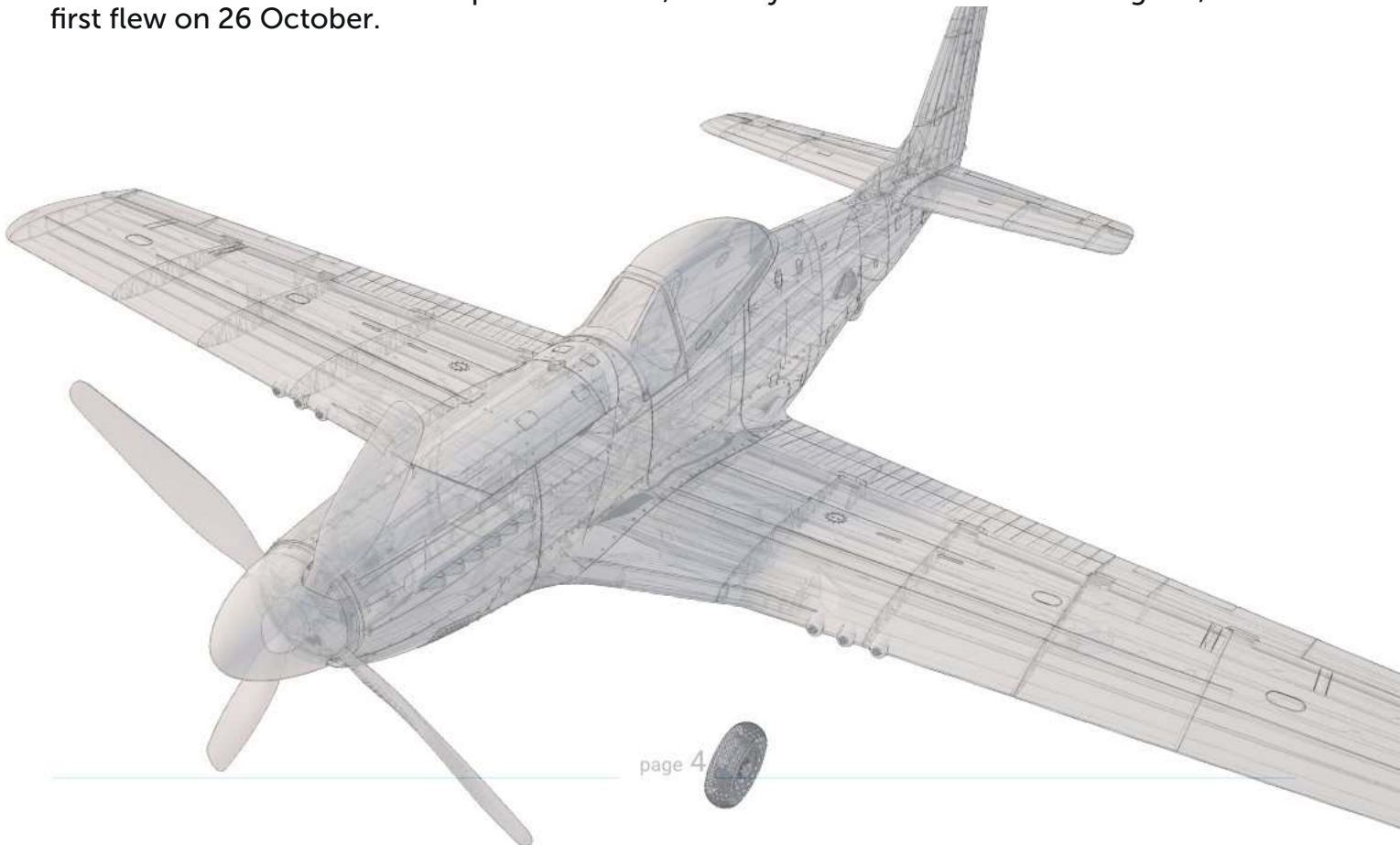

## Included:

### 1. 3MF 3D files (primary)

#### Used instead of STL files

3MF files can be used instead of standard STL files, but also include information about slicing in the new version of **Prusa Slicer (since version 2.4)**. Open them directly in the Prusa Slicer as a project or import to the slicer of your choice. The files contain settings for printing on a direct drive printer with dimensions 200x200x200 mm, that can be further adapted to suit your printer. The generic settings are compatible with Prusa MK2/3/3S printers.

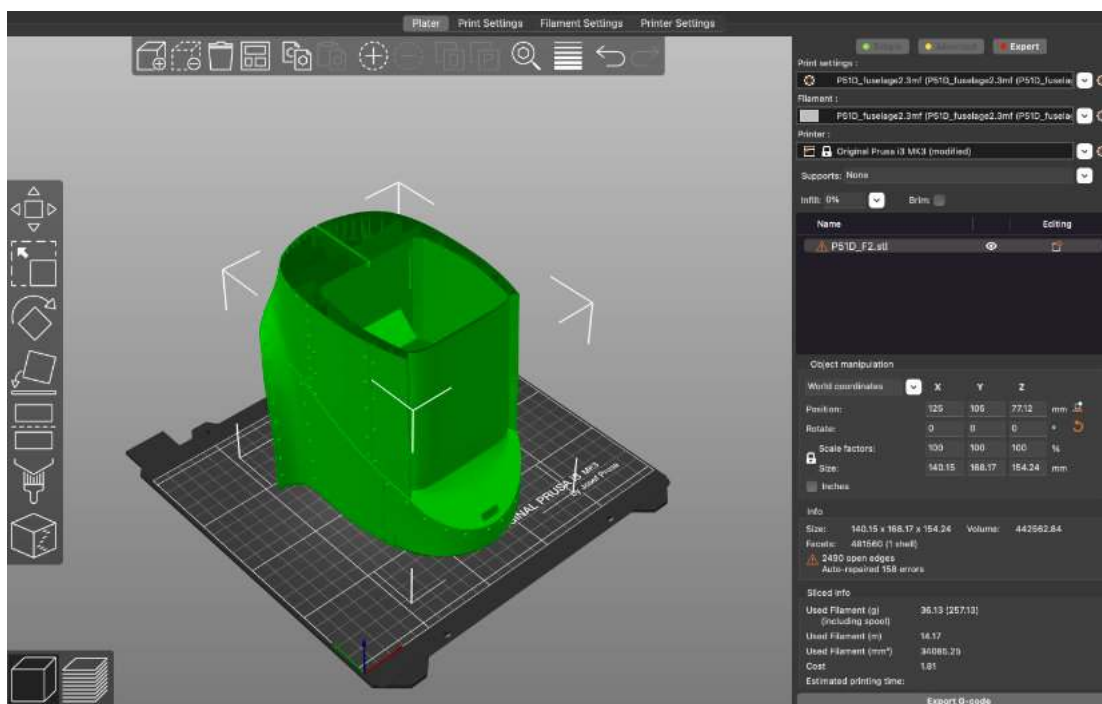

### 2. STL files - universal for all slicers

STL files are no longer necessary, as 3MF files can be imported to any slicer (Cura, Simplify3D) same as the STL files. Please use the 3MF files instead which contain more information than plain STL.

### 3. Printing Guide in our Help Section

Apart from this userguide, please see the Printing Guide for [PrusaSlicer](#), [Simplify3D](#) or [Cura](#) to find some Tips and Advice for airplane printing (Thin Wall Printing). **Remember: We use 0 retraction and 0.4-0.5 flow with LW-PLA.**

### 4. Gcodes

Basic Gcodes prepared for direct use, as universal as possible. Should work on i3 style printers, Give it a try, but we can't guarantee it will work on your printer. Wall thickness should be 0.55-0.67mm.

## 5. Scale markings PDF

You could print and cut the PDF in scale from thin self adhesive advertisement foil and place it on the model as needed. it is good to contact an advertising/graphic workshop in your area, we have good experience with UV printing on thin film



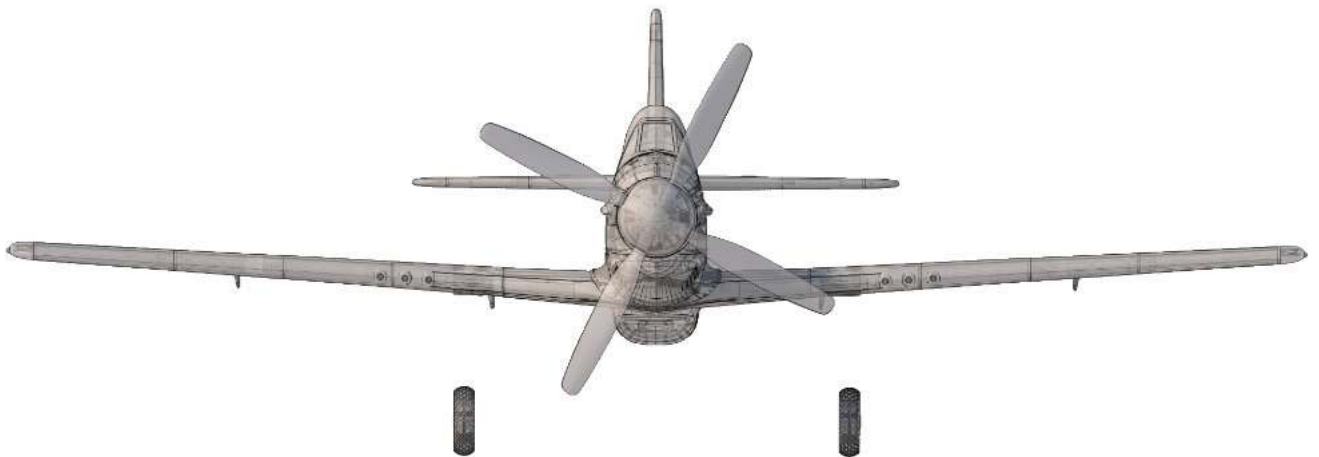
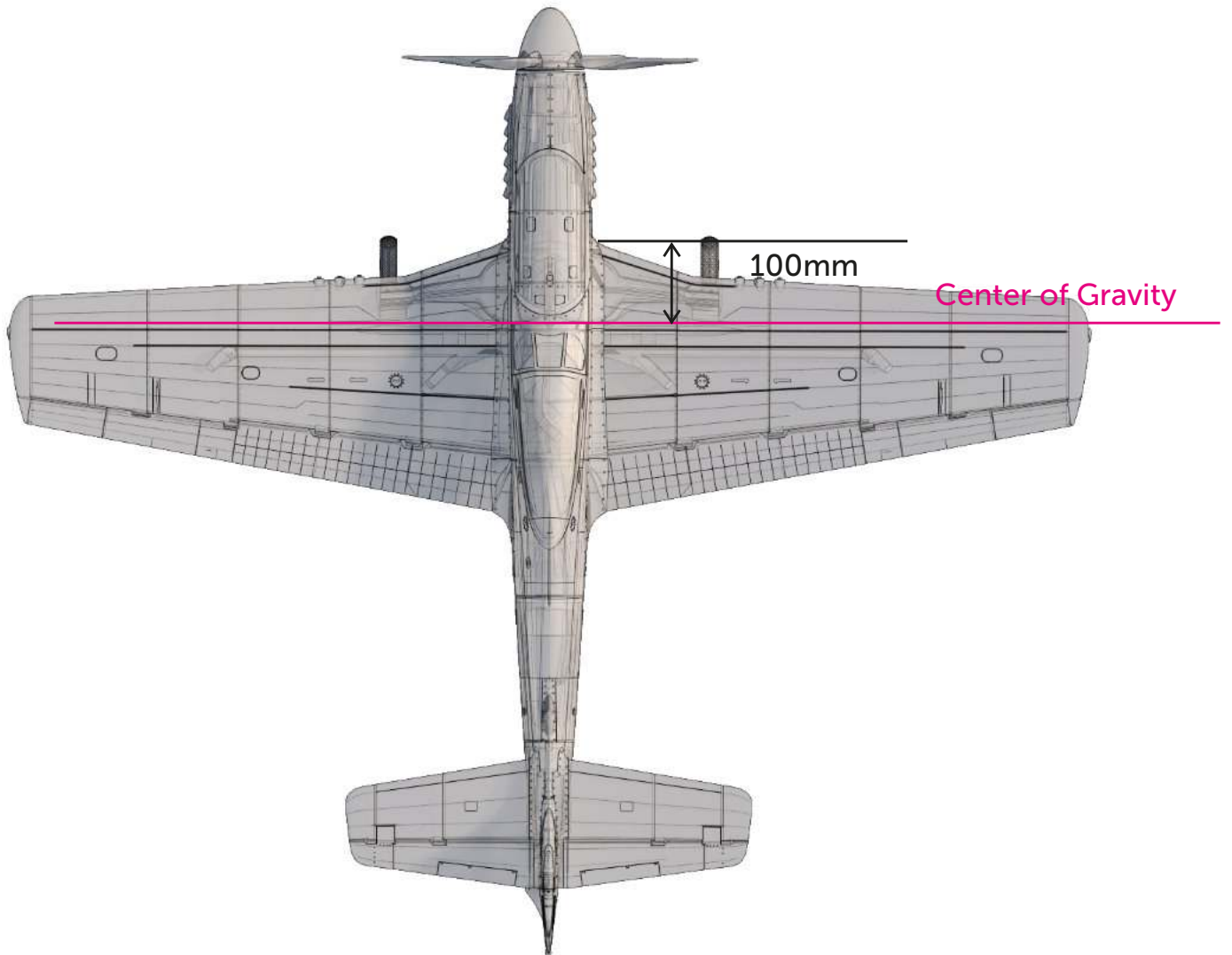

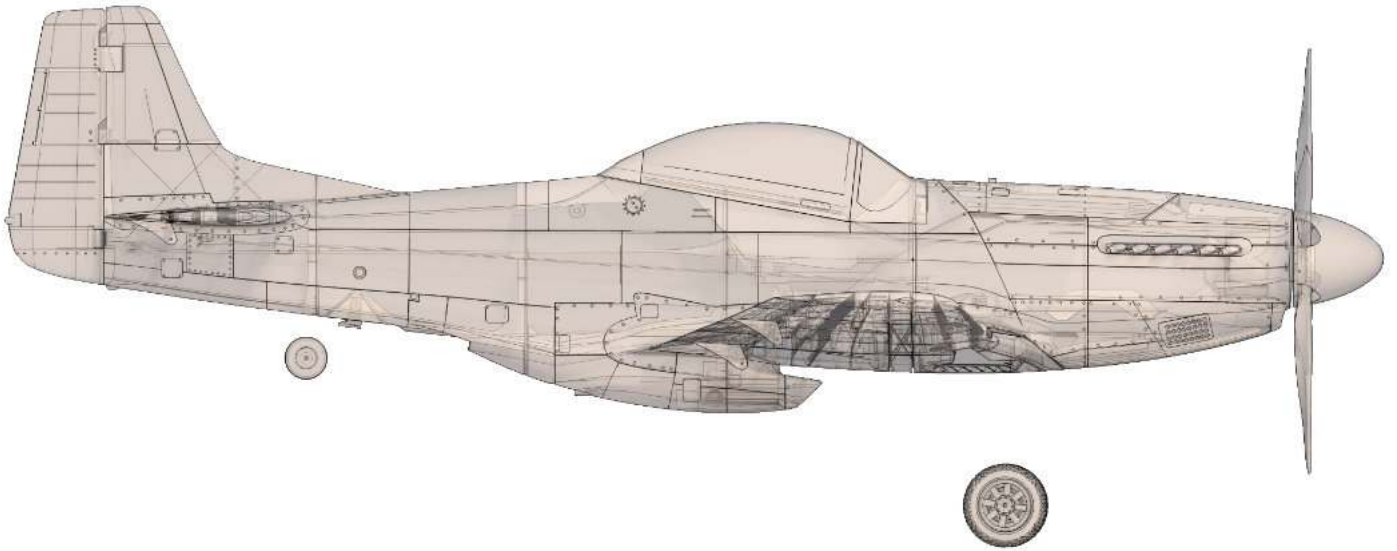



## Step By Step PDF/VIDEO userguide

1. Choose airplane at [www.3DLabprint.com](http://www.3DLabprint.com), visit our [Facebook](#) for latest info.



Basic requirments for P-51D Mustang are 200/200/195 mm volume, nozzle 0.4mm. Heated bed recommended. Designed to be printed with [Polylight LW-PLA filament by 3DLabPrint](#).

Contact: [support@3dlabprint.com](mailto:support@3dlabprint.com)

## 2. Create account, download

You will receive download link to all the zipped files to your email right after the checkout (please check your spam folder if not). If you are logged in with your account while purchasing the model, you will find the download link in your account's Downloads section on our website. Please contact [support@3dlabprint.com](mailto:support@3dlabprint.com) if you have trouble getting the files.

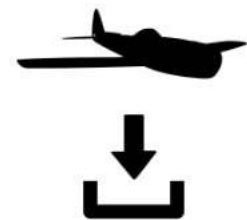

## 3. Prepare Gcodes

option A Gcodes:

if your printer is i3 comptatible you can use [prepared gcodes](#) directly. Just save them to the SD card and let the 3d printer do it's job. HE temperature is set to 240°C so the layers fuse together well, you can adjust speed and temperature only through your printer's LCD. If these Gcodes does not work for you, please proceed to the next options.

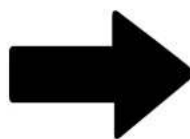

### option B Prusa Slicer 3mf files (recommended)

Please follow the guide in the Help section of our website about [Prusa Slicer setup](#).

Drag and drop the 3mf file to the Prusa Slicer window and open it as a Project. It will create a Generic 3DLabPrint printer, printing profile and materials. Please use these as a starting point instead of your printer profiles provided by your printer manufacturer. Strong thin-wall printing is a different discipline than printing Benchys what are the stock profiles usually optimized for. Once you tweak your profiles (retractions, etc.) you can easily switch the profile everytime you open the 3mf file. All the slicing tweaks, such as added top/bottom layers etc. are stored in the models below, so it won't be overwritten.

**Remember: We are using 0.5 multiplier and 0 retraction with LW-PLA.**

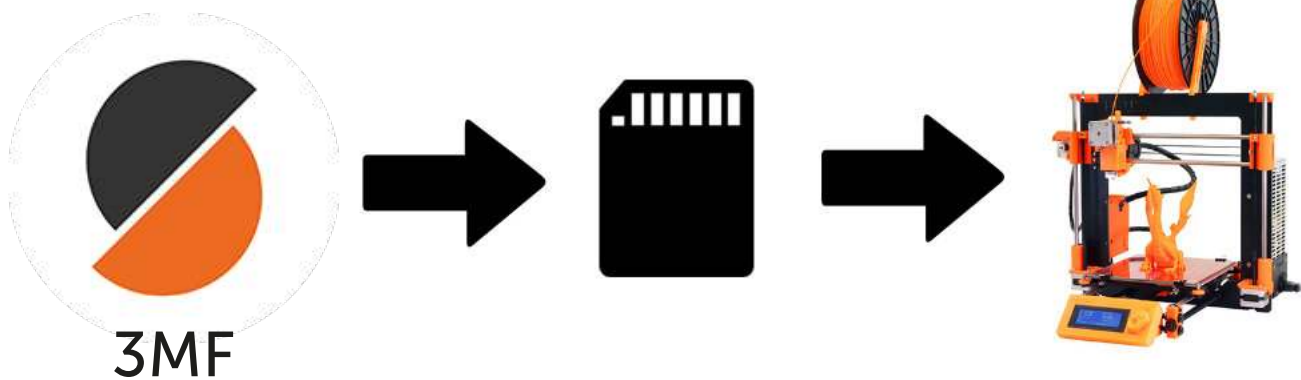

This method is also suitable for other common brands of printers, such as Creality (Enders), BambuLab and other. Prusa Slicer provides all the features we need and the settings are preconfigured in the 3mf files. Use the Print Settings and Filament profiles from our 3mf files and your Printer profile to ensure the compatibility.



**Note: Simplify3D factory files are no longer provided as 3mf files are full substitute for them.**

### option C CURA or Simplify3D

CURA and Simplify3D option is for advanced users who insist on using it. There's no advantage compared to Prusa Slicer option but it still remains available. If you struggle with setting up Cura or Simplify3D, please use the option above which provides better results by default. You can import the Prusa Slicer 3mf files just like any other STL files but it won't import any print settings.

Please check our [CURA guide](#) or [Simplify3D guide](#). Please visualise our presliced gcodes to see how the result should look like and try to achieve the same in your slicer.

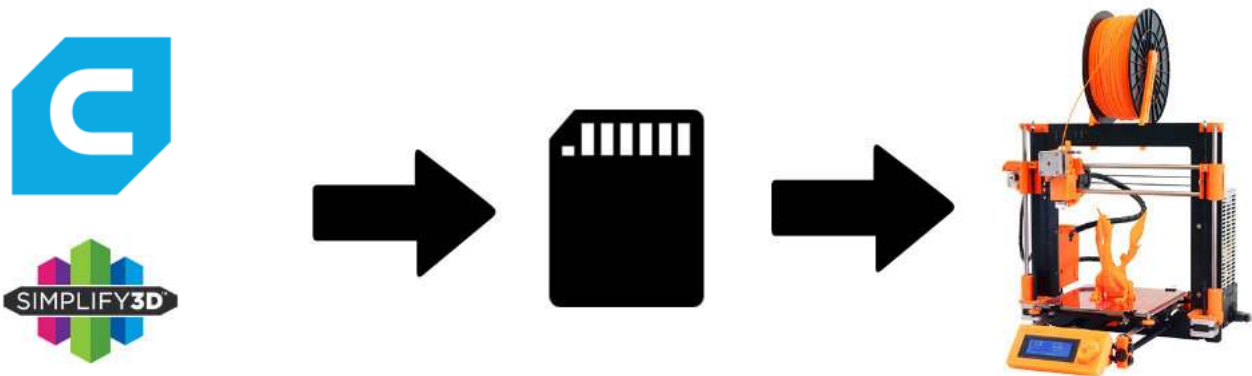

**Remember: We are using 0.5 extrusion multiplier and 0 retraction with LW-PLA.**



## 4. Print it

Save the Gcodes to the SD card and insert into your printer. Prepare your printer and start printing, we prefer to use SD card rather than direct USB connection. Scaling the model will lead to unusable result!

you will need: LW-PLA filament - ([Polylight LW-PLA](#))  
3DLac, Strong hair spray, PEI or your favorite adhesive bed surface

AND... please watch our VideoGuides:



### Basic Tips and Advice

This plane has been designed to be printed from foaming LW-PLA that means about 50% weight reduction on printed parts.

Please Experiment with temperature and extrusion multiplier (0.55-0.67mm Wall thickness). Hotend temperature is very important (220° up to 260° celsius). The temperature determines, how much the LW-PLA foams while printing. Cranking up temperature means, you can go lower on multiplier as the material will gain on volume. Turn OFF cooling fan for better layer adhesion (HE fan should be ON). We dont need it for thin wall printing. Heated bed is very recommended, 55-58° Celsius (to prevent warping ends).

Price of the LW-PLA may look a bit steep at first glance, but since we're using 50% less material thanks to the foaming feature, the cost difference is not so high as it looks.

Please see the [Printing Guide \(Help Section\)](#)

## How to print PolyLight LW-PLA?

The basic print setup is almost the same as we use for standard PLA. The only difference is in extrusion multiplier set to 0.5 and turning off the retractions completely.

This results in parts with half the weight and still suitable mechanical properties, this model is designed mainly in VASE mode, even that expect some stringing inside and outside in some impossible spots. Of course you can try to tweak the retractions for less stringing inside the parts, but there's a high risk of clogging the nozzle or throat. Increasing the retraction distance above 1 mm is not recommended at all and leads to nozzle clogs caused by foaming. Cleaning the hairy, but functional parts after printing with retractions completely disabled seems to be more efficient method. The nozzle is permanently pressurized and you don't need to worry about print failures. This method works fine even for bowden printers.

Extrusion multiplier 0,5 has been tested for easy print with massive weight saving around 50%. Feel free to experiment with extrusion multiplier and temperatures at will for the best results on your printer. This airplane is designed for **0.55 - 0.67mm** Wall thickness.

Cosmetic issues of the prints are easily fixed with snap knife or sand paper, as the LW is easily sanded and cut.



## P-51D Mustang, list of printed parts (weights):

### fuselage

F1 (PolyAir strong PLA)	108 g
F2 (PolyLight LW PLA)	36 g
F3 (PolyLight LW PLA)	33 g
F4 (PolyLight LW PLA)	42 g
F5 (PolyLight LW PLA)	23 g
F6 (PolyLight LW PLA)	21 g
Canopy 1 (PolyAir strong PLA)	17 g
Canopy 2 (PolyLight LW PLA)	12 g
Canopy 3 (PolyLight LW PLA)	2 g
Fuselage cover 1 (PolyLight LW PLA)	10 g
Fuselage cover 2 (PolyLight LW PLA)	2 g
Fuselage cover lock (PolyAir strong PLA)	2 g
Exhaust (PolyAir strong PLA)	6 g
Spinner plate (PolyAir strong PLA)	17 g
Spinner 2blade (PolyLight LW PLA)	8 g
Motor mount (PETg)	20 g
Batt holder (PolyAir strong PLA)	6 g
<b>fuselage total</b>	<b>365 g</b>

### wing

wing L1A (PolyLight LW PLA)	30 g
wing L1B (PolyLight LW PLA)	8 g
wing L2 (PolyLight LW PLA)	23 g
wing L3 (PolyLight LW PLA)	17 g
wing L4 (PolyLight LW PLA)	14 g
wing L5 (PolyLight LW PLA)	14 g
wing L6 (PolyLight LW PLA)	3 g
wing R1A (PolyLight LW PLA)	31 g
wing R1B (PolyLight LW PLA)	9 g
wing R2 (PolyLight LW PLA)	23 g
wing R3 (PolyLight LW PLA)	17 g
wing R4 (PolyLight LW PLA)	14 g
wing R5 (PolyLight LW PLA)	14 g
wing R6 (PolyLight LW PLA)	3 g
lap L1 (PolyLight LW PLA)	6 g
lap L2 (PolyLight LW PLA)	4 g
lap L3 (PolyLight LW PLA)	4 g
lap R1 (PolyLight LW PLA)	6 g
lap R2 (PolyLight LW PLA)	4 g
lap R3 (PolyLight LW PLA)	4 g
aileron L1 (PolyLight LW PLA)	2 g
aileron L2 (PolyLight LW PLA)	3 g
aileron L3 (PolyLight LW PLA)	2 g
aileron R1 (PolyLight LW PLA)	2 g
aileron R2 (PolyLight LW PLA)	3 g
aileron R3 (PolyLight LW PLA)	2 g
radiator 1 (PolyLight LW PLA)	13 g
radiator 2 (PolyLight LW PLA)	8 g
<b>wing total</b>	<b>283 g</b>

### tail

elevator 1L (PolyLight LW PLA)	1 g
elevator 2L (PolyLight LW PLA)	6 g
elevator 3L (PolyLight LW PLA)	1 g
elevator 1R (PolyLight LW PLA)	1 g
elevator 2R (PolyLight LW PLA)	6 g
elevator 3R (PolyLight LW PLA)	1 g
H stabilizer L1 (PolyLight LW PLA)	6 g
H stabilizer L2 (PolyLight LW PLA)	4 g
H stabilizer L3 (PolyLight LW PLA)	2 g
H stabilizer R1 (PolyLight LW PLA)	6 g
H stabilizer R2 (PolyLight LW PLA)	4 g
H stabilizer R3 (PolyLight LW PLA)	2 g
rudder 1 (PolyLight LW PLA)	3 g
rudder 2 (PolyLight LW PLA)	2 g
rudder 3 (PolyLight LW PLA)	7 g
rudder 4 (PolyLight LW PLA)	2 g
rudder 5 (PolyLight LW PLA)	1 g
V stabilizer 1 (PolyLight LW PLA)	4 g
V stabilizer 2 (PolyLight LW PLA)	2 g
<b>tail total</b>	<b>61 g</b>

### landing gear

LG disc L+R + tail (PolyAir strong PLA)	26 g
main tyre L+R (varioShore TPU/flex filament)	30 g
tail tyre (varioShore TPU/flex filament)	4 g
tail LG housing (PolyAir strong PLA)	4 g
tail LG socket (PolyAir strong PLA)	3 g
<b>landing gear total</b>	<b>67 g</b>

## Wing assembly

Glue main wing parts L1A+L1B-L6 together. Repeat for the right side. Glue both halves of the wing together. Use medium CA glue, and use activator to speed up the glue curing. Press in and glue a piece of PolyAir into the top and bottom opening to create a wing spar and improve the rigidity of the wing, than add thin CA (if you don't have one, use a medium) glue over and use activator for CA glue.

Glue the ailerons/flaps L1-L3 and repeat for the right side. Cut out L/R6 on the aileron side. Use a filament as a hinge. Just slide it in, there's no need to glue the hinge for easy aileron or servo replacement. Although it is shown in the video we don't need any carbon tube in the wing

[Video guide P-51D Mustang wing assembly](#)



you will need: [CA Glue - medium](#) + [Activator for CA Glue](#)  
[CA Glue - thin](#)  
[PolyAir](#) or any filament

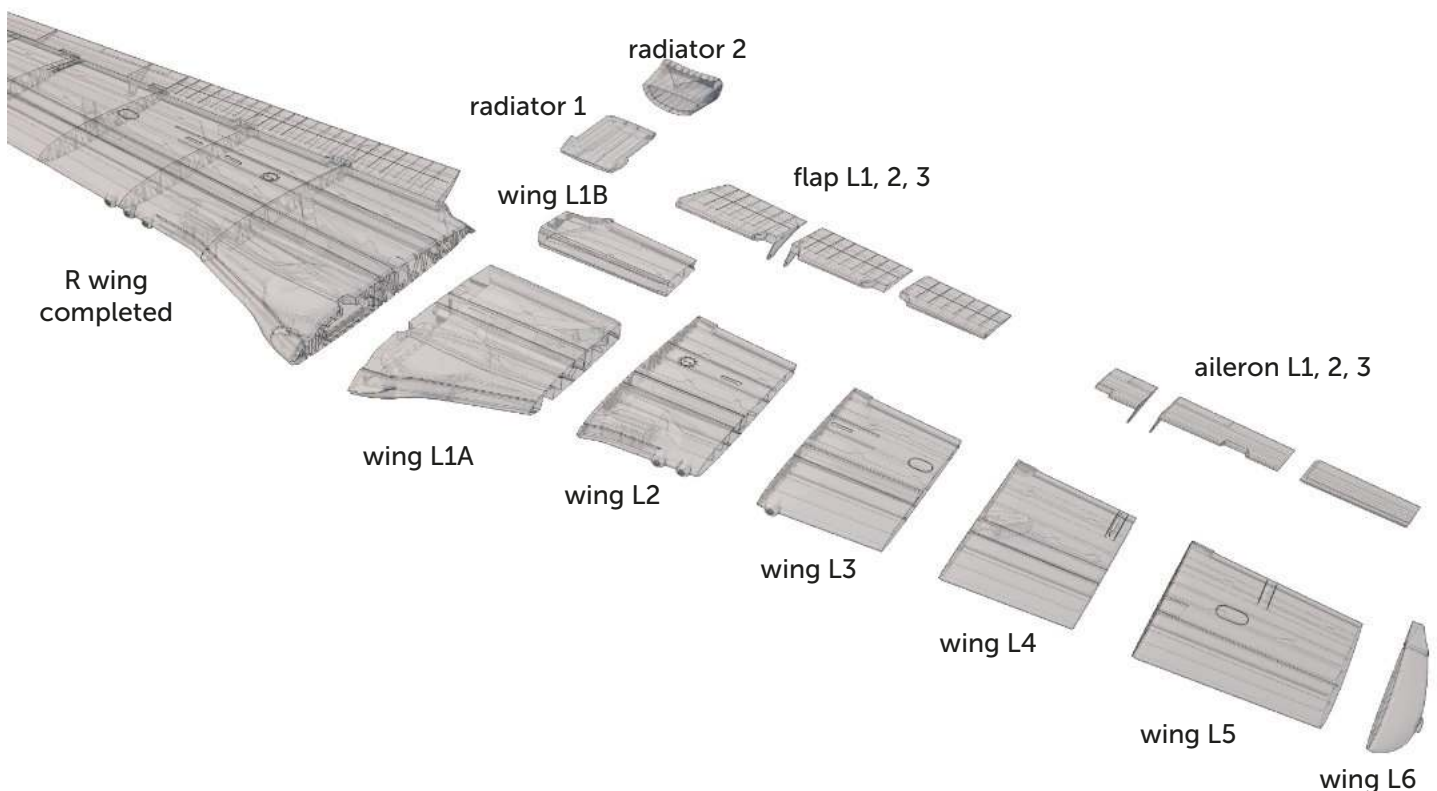

## Fuselage assembly

You can use snap knife for cleaning the surface of printed parts, but mostly it is not necessary. Glue fuselage parts F1-F6 with CA glue together. For fuselage cover lock use a ball pen spring.

[See video guide P-51D Mustang fuselage assembly](#)



you will need: [CA Glue - medium](#) + [Activator for CA Glue](#)  
Ball Pen Spring

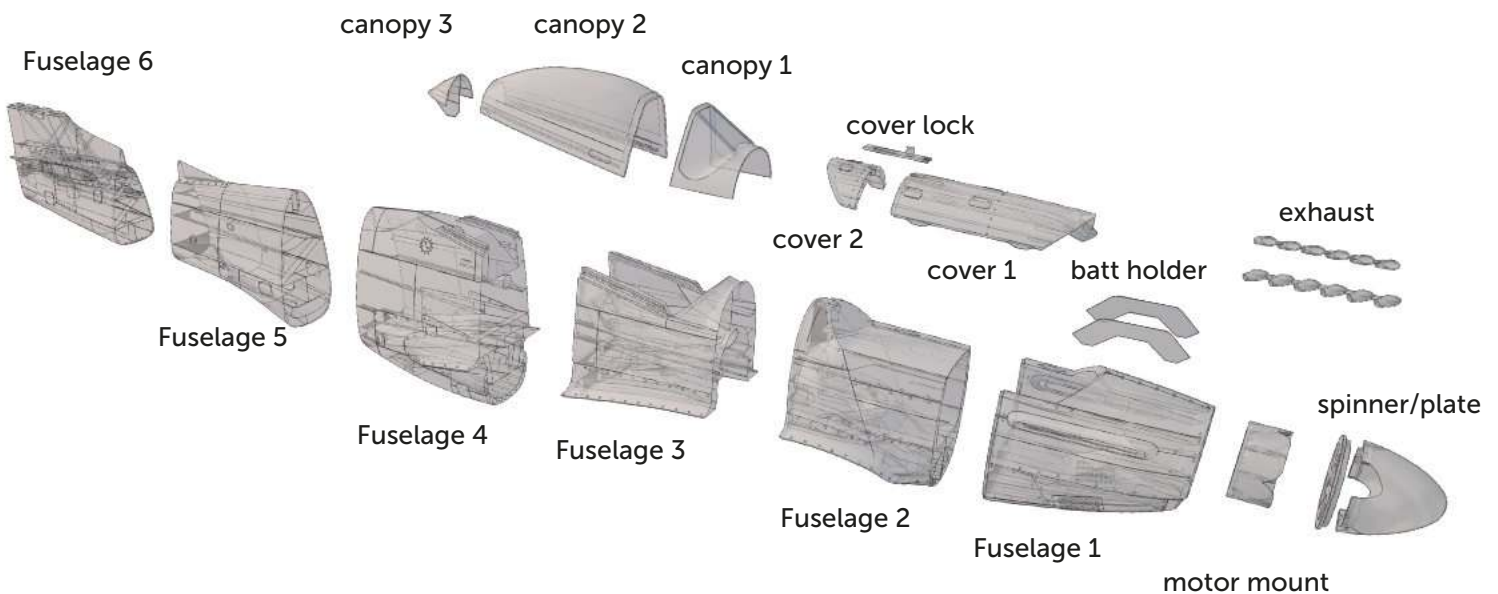



## Tail assembly

Glue L/R1, 2, 3 parts of the V and H stabilizer and elevator. Glue the stabilizers perfectly perpendicular to the fuselage. Assemble both sides of the elevator with the elevator arm on a flat surface. Mount the elevator assembly to the stabilizer using the piece of PolyAir filament. Check the functionality of the elevator and rudder assembly carefully.

[See video guide P-51D Mustang tail assembly](#)



you will need: [CA Glue - medium](#) + [Activator for CA Glue](#)  
[PolyAir](#) or any filament

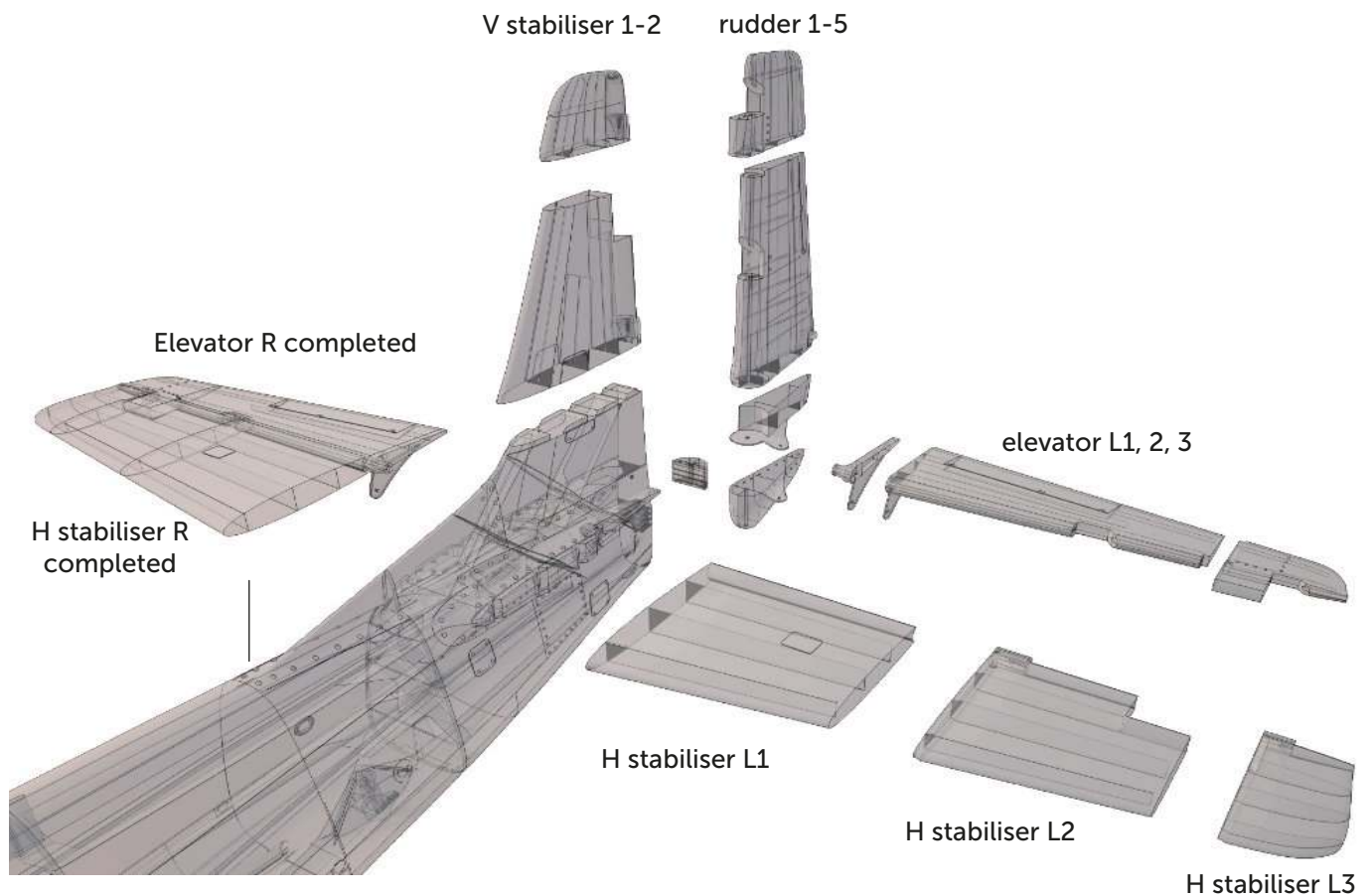

## Servo installation

Check the servos with servotester or your RC system. Install the prepared servos to wing servo bays. Use a 1.2mm steel wire with Z bends as a linkage between the servos and flaps/ aileron control horns. Two elevator servos will be fixed in the fuselage (one for each elevator L+R). One servo for rudder. For rudder and elevator we recommend 0.8mm wire.

[See video guide P-51D Mustang servo installation](#)



you will need:

- 7x [HXT900](#) or any similar sized servos
- 23x12x26 mm / 0.74x0.42x0.78 inches
- [Servo cable extension](#)
- [Z pliers](#)
- 1x1.2mm steel wire (flaps/ailerons)
- 3x0.8mm steel wire (elevator/rudder)



## Main Landing Gear assembly

Use hammer and vice to shape steel wire to fit the main LG leg pattern. Check the functionality of the landing gear assembly carefully. As a option you can use fixed landing gear - LG fixed socket and main LG fixed leg pattern (find in fixed LG directory)

[See video guide P-51D landing gear assembly](#)



you will need: 3 mm spring-steel wire  
[Retracts](#) (stop colar included) or similar [opt2](#)  
 8x self-taping screw 3x20mm  
 Hammer and vice

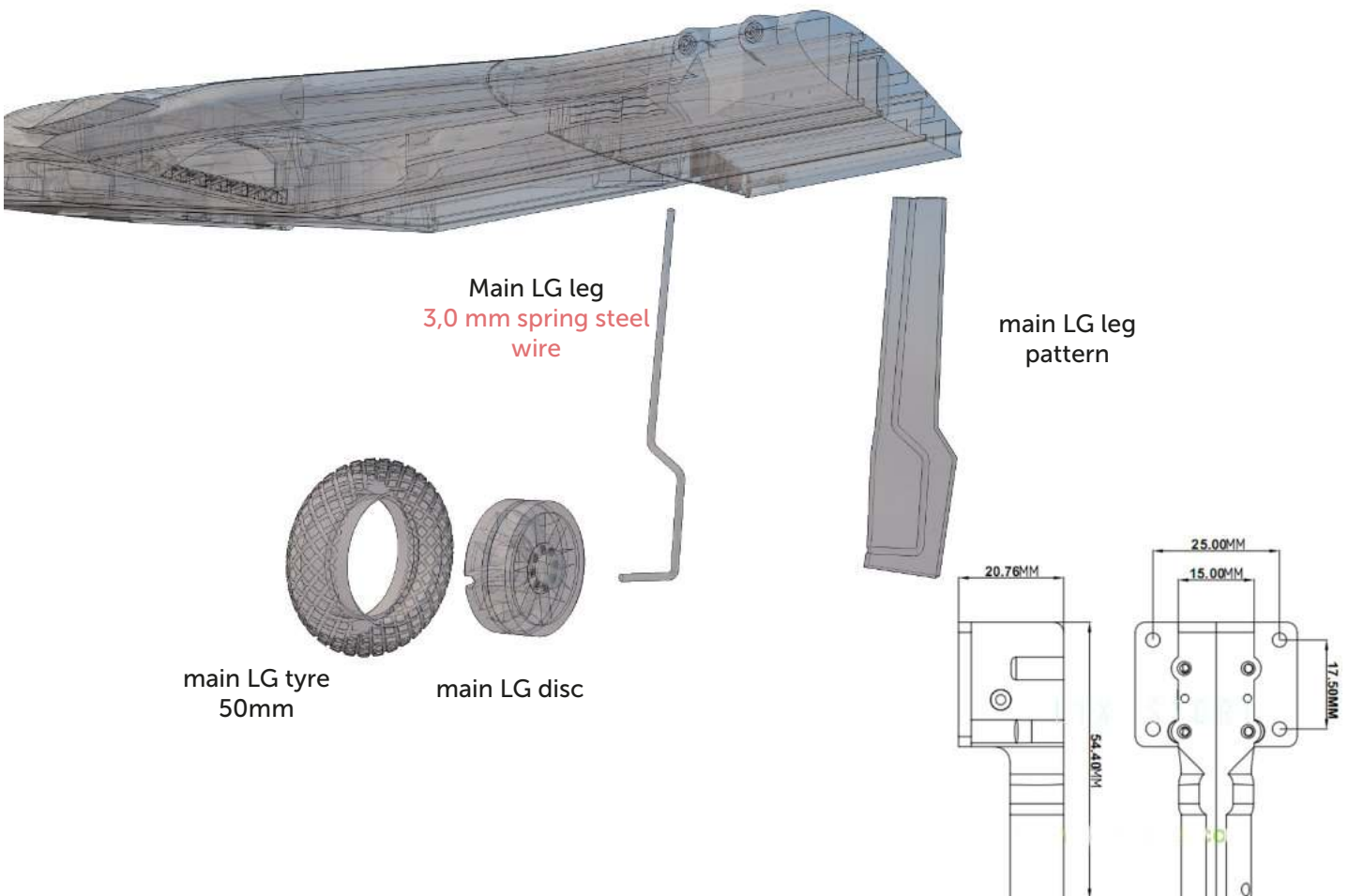

## Tail Landing Gear assembly

Put gear tyres on the rims. Use the remaining 1mm wire to shape the rear chassis to your taste. Secure the rear wheel against sliding out with a small washer and cover with glue or crimp the small brass servo bushing with pliers. Weave the entire rear wire into the rudder and bend towards the rear. Check the functionality of the landing gear assembly carefully.

[See video guide P-51D landing gear assembly](#)

you will need:

- 2 mm steel wire
- 2mm stop colar
- 1x [HXT900](#) or any similar sized servos
- 1x0.5-0.8mm steel wire

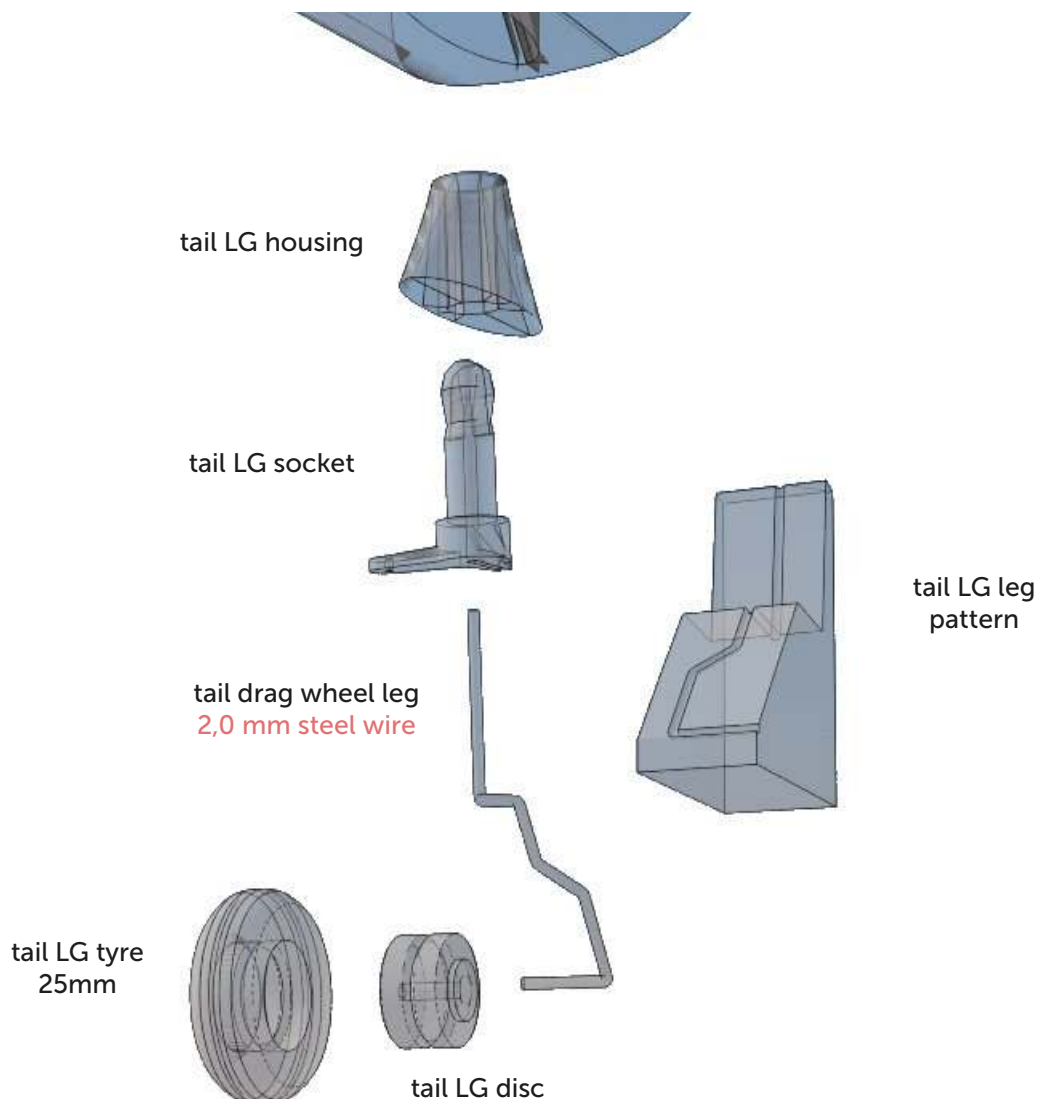

## Motor Setup

.Mount the motor using 4x M3 screws and nuts to the printed motor mount. Find the perfect position, the gap between spinner and fuselage should be 2-3mm. Glue universal motor mount with motor into the fuselage with CA glue. Fix the battery by velcro tape and battery holder to the fuselage. We recommend using a LW PLA spinner, but you have to clean the print in this case (not vase mode).

[See video guide P-51D Mustang motor setup](#)



you will need:

- 4x M3x12mm screws + nuts + washers
- Motor: [3542 / 1000KV](#) or similar
- ESC: [40A/3s](#) or similar
- Propeller: two blade 12 x 6
- Battery: [2200mAh/3s](#) or similar

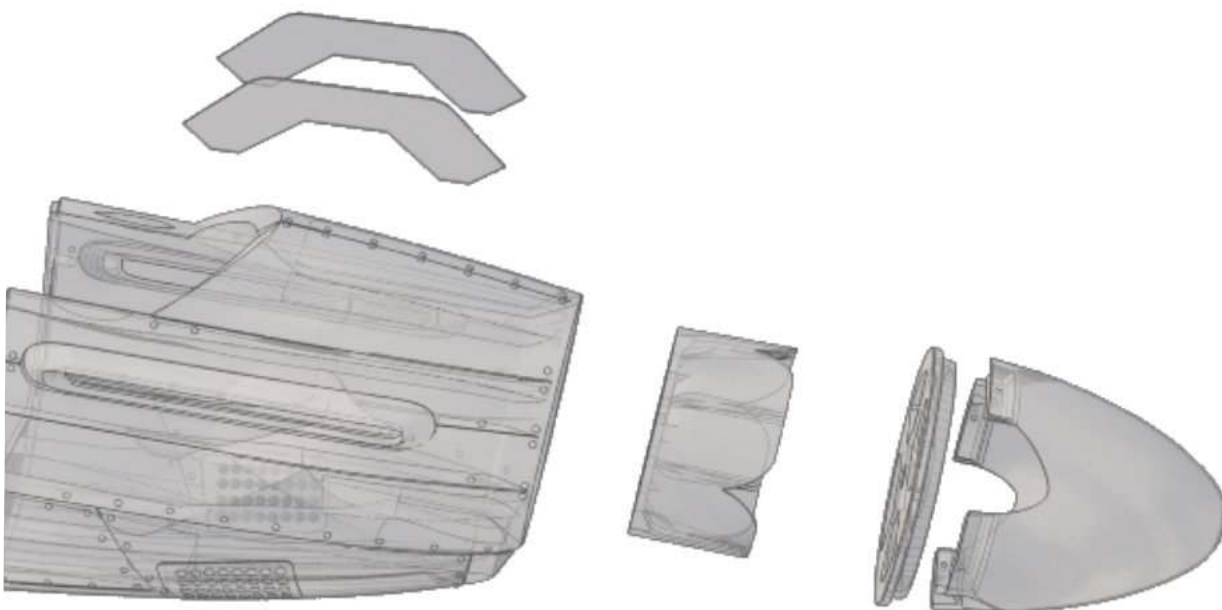

## Painting/marketing decals

Another advantage of Polylight LW-PLA is that it can be dyed with almost anything. The surface for self-adhesive decals is ideally treated with a clear acrylic spray varnish. Use your imagination and send us photos of your aircraft on social networks. You could print and cut the PDF in scale from thin self adhesive advertisement foil and place it on the model as needed. it is good to contact an advertising/graphic workshop in your area, we have good experience with UV printing on thin film

[See video guide decals/marketing](#)



## Final assembly/setting

Refer to your R/C system userguide for setup information.

you will need: Your own Rx/Tx system

Velcro strip & Rubber Bands (for wing)

Install your receiver, connect battery, setup servos and etc. with your transmitter, check servo position, then install propeller.

**Make sure the battery is positioned properly and secured with velcro or battery holder, if battery moves during flight it can shift the center of gravity backwards and aircraft will become uncontrollable! Never set ESC with propeller installed, this could be very dangerous!**

[See video guide P-51D Mustang final setting](#)



### aileron

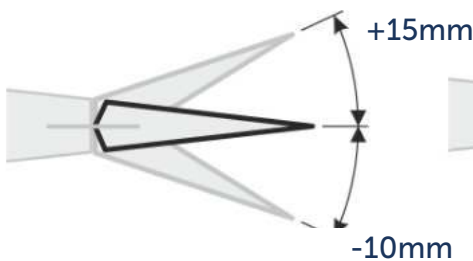

### elevator

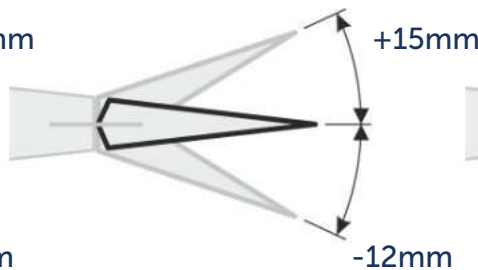

### rudder

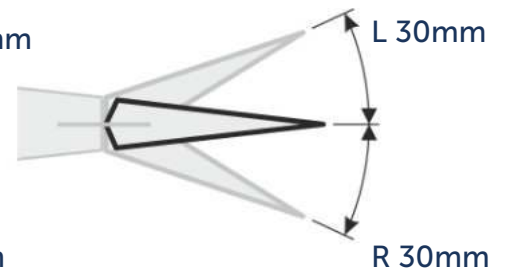

## 9. Go flying

Pre-flight check **center of gravity is very important** (move it 5mm forward for the first flights), battery properly charged, ailerons and elevator deflection check, your own flying skills or RC simulator training ...

[Flight video](#)



## 10. Pilots Please Attention!

For the first flights we recommend setting the center of gravity to around 5 mm forward of the CG tag - nose heavy, this increases the stability (you can use heavier battery). Increasing expo settings on your transmitter for elevator and ailerons to 80 % calms response from your stick inputs. Also you can decrease elevator, rudder and ailerons deflection to calm down the plane.

Make sure the battery is well fixed in proper position. If it moves during flight it will cause shifting of CoG aft and will result in uncontrollable flight behavior.

After gaining some confidence you can balance the plane to the Center of Gravity marks and set Expos to 60 % as shown in the video/instructions... this gains back extra maneuverability.

**Never fly aft positioned Center of gravity.**

Please, use these files only for your own purpose, do not redistribute or publish. Thank you very much.  
Enjoy your flight.

