



Skynetic

Micro Plane User Manual

NOTICE

The following terms are used throughout the product literature to indicate various levels of potential harm when operating this product:

WARNING: Not following procedures may result in property damage, collateral damage, superficial injury, or serious injury.

WARNING

Age Recommendation: Not for children under 14 years. This is not a toy.

Read the ENTIRE instruction manual to become familiar with the features of the product before operating. Failure to operate the product correctly can result in damage to the product, personal property and cause serious injury. Do not use with incompatible components or alter this product in any way outside of the instructions.

Safety Precautions and Warnings

- Always keep a safe distance around your model to avoid collisions or injury. This model is controlled by a radio signal subject to interference from any sources outside your control. Interference can cause momentary loss of control of the model.
- Always operate your model in open spaces away from buildings, vehicles, traffic, and people.
- Always follow the directions and warnings for this and any optional support equipment. (Chargers, rechargeable battery packs, etc.).
- Always keep all chemicals, small parts, and anything electrical out of the reach of children.
- Always avoid water exposure and moisture to all equipment not specifically designed and protected for this purpose.
- Never place any portion of the model in your mouth as it could cause serious injury or even death.
- Never operate your model with low transmitter batteries.
- Always keep aircraft in sight and under control, keep the transmitter powered on before aircraft is powered.
- Always use fully charged batteries, remove batteries before disassembly, remove batteries after use.
- Always keep parts clean and dry, let parts cool after use before touching.

Battery and Charging Warnings

The USB charger has been designed to safely charge the included Li-Po battery.

CAUTION: All instructions and warnings must be followed exactly. Mishandling of Li-Po batteries can result in a fire, personal injury and/or property damage.

- By handling, charging, or using the included Li-po battery, you assume all risks associated with lithium batteries.
- If at any time the battery begins to swell, **DISCONTINUE USE IMMEDIATELY.**
- Always store the battery at room temperature in a dry area for best results.
- Always transport or store the battery in a temperature range of 40 – 120° F. Do not store the battery or model in a car or in direct sunlight. Failure to do so can result in damage to the battery or may result in a fire.
- Always charge batteries away from flammable materials.
- Always inspect the battery before charging and monitor the temperature of the battery pack while charging.
- Always disconnect the battery after charging, and let the charger cool between charges.
- **ONLY USE THE CHARGER SPECIFICALLY DESIGNED TO CHARGE THE LI-PO BATTERIES.** Failure to charge the battery with a compatible charger may cause a fire.
- Never discharge Li-Po cells to below 3.0V under load.
- Never cover warning labels with hook and loop strips.
- Never leave charging batteries unattended.
- Never charge batteries outside recommended levels.
- Never charge damaged batteries.
- Never attempt to dismantle or alter the charger.
- Never allow minors to charge battery packs.
- Never charge batteries in extremely hot or cold places (recommended between 40-120° F or 5-49°C) or place in direct sunlight.

Charging the Battery

CAUTION: Once charging is complete, immediately remove the battery. Never leave a battery connected to the charger.

1. Insert the charger into a USB port.
2. Properly connect the battery to the charger.
3. Charging a fully discharged (not over-discharged) 500 mAh battery takes approximately 30-40 mins.
4. The LED Solid Red means charging, the LED off means charging is complete.

Installing the Battery

The transmitter comes pre-bound to the aircraft, so binding should not be necessary.

Keep the aircraft and transmitter away from large metal objects, wireless sources or other transmitters while installing the battery.

CAUTION:

- Before flying, power on the transmitter first, then power on the plane. After flying, power off the plane first, then power off the transmitters.
- Always disconnect the Li-Po battery from the aircraft receiver when not flying to avoid over-discharging the battery. Batteries discharged to a voltage lower than the lowest approved voltage may become damaged.
- Always keep hands away from the propeller. When armed, the motor will turn the propeller in response to any throttle movement.

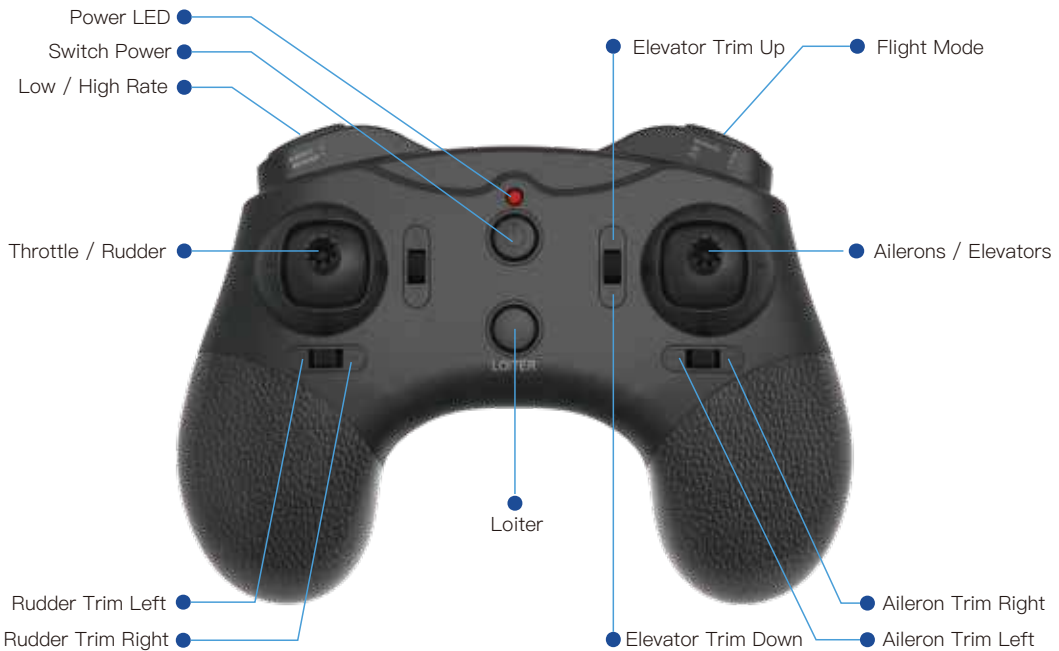

Transmitter Batteries Installation

Remove the battery cover. Install the four batteries (noting proper polarity) and reinstall the battery cover.

Transmitter Low Battery Alarm

When the battery transmitter voltage drops too low, an alarm sounds (D.B.D.B). The batteries must be replaced immediately. If this happens while flying, land your aircraft as soon as possible.

Transmitter LED Indicator

The radio will have acoustic timing per minutes, so you will hear "B.B.B" in every 1 minute.

After 10 minutes, it will keep "B.B.B. B.B.B" every 1 minute. This will help you know how long you have flown.

STATUS	Transmitter LED Indicator
Transmitter voltage too low	Transmitter keeps beeping "D.B.D.B", LED slow flashing.
Aircraft voltage	When aircraft voltage is less than 3.3V, you will feel the plane is losing powered. You can still fly for another 2 minutes, which will give you the time to land the plane.
Control rate	1 beep means Beginner Mode (Low rate). 2 beeps means Expert Mode (High rate).
Flight Mode	1 beep means 6G Mode. 2 beeps means 3D Mode. 3 beeps means Manual Mode. When you power on the radio, it is in 6G Mode as a default setting.

Flying Tips

- Consult local laws and ordinances before choosing a location to fly your aircraft.
- The built-in Flight Controller System is designed as flight assistance, **NOT AN AUTOPILOT.**
- Start in Beginner mode. As you learn and become more confident, change modes to advance your flying skills.
- Always make deliberate and steady control stick movements for smooth control of your aircraft.
- Fly your aircraft outside in no greater than light winds.
- Indoor flight is not recommended.
- Keep your aircraft in plain sight and up wind.
- Always avoid flying near houses, trees, wires, and buildings.
- Always avoid flying in areas where there are many people, such as busy parks, schools or playing fields.

Included in the Box

1x airplane	1 x spare parts bag
1 x transmitter (Not include in FTR version)	1 x manual
1 x USB charger	1 x screwdriver
1 x landing gear set	1 x battery

Installation:

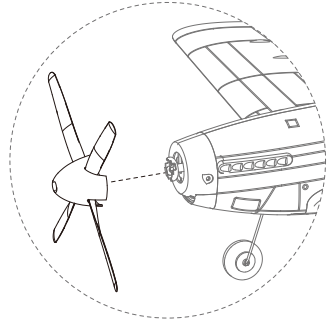
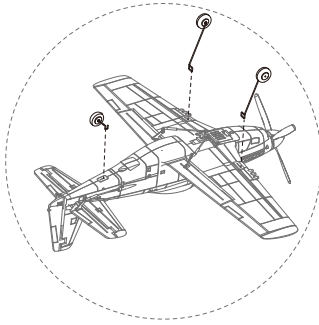
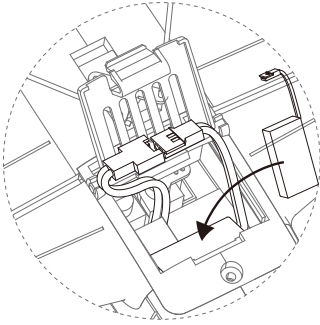

Different Flight Modes

6G Mode (with self leveling): Pitch (nose up and down) and Roll (wing tips up and down) angles are limited to help you keep the aircraft airborne. Release both sticks for self-leveling.

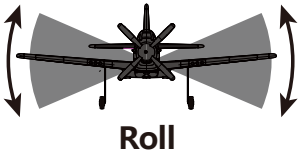

Roll

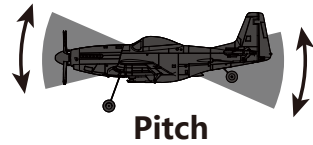

Pitch

3D Mode: The pilot is only prevented from entering extreme flight conditions.

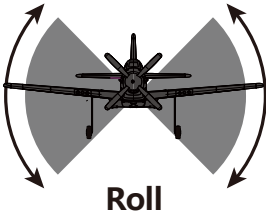

Roll

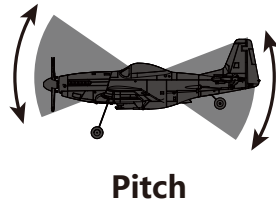

Pitch

Manual Mode: Unlimited Flight Capability

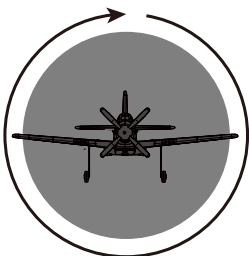

Roll

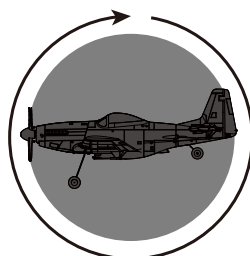

Pitch

LOITER function:

Press LOITER button, the plane will keep circling in a 20m diameter circle in any altitude when you press the button. Throttle / Rudder will not de-trigger the Loiter, but moving the Ailerons / Elevator stick will de-trigger the Loiter.

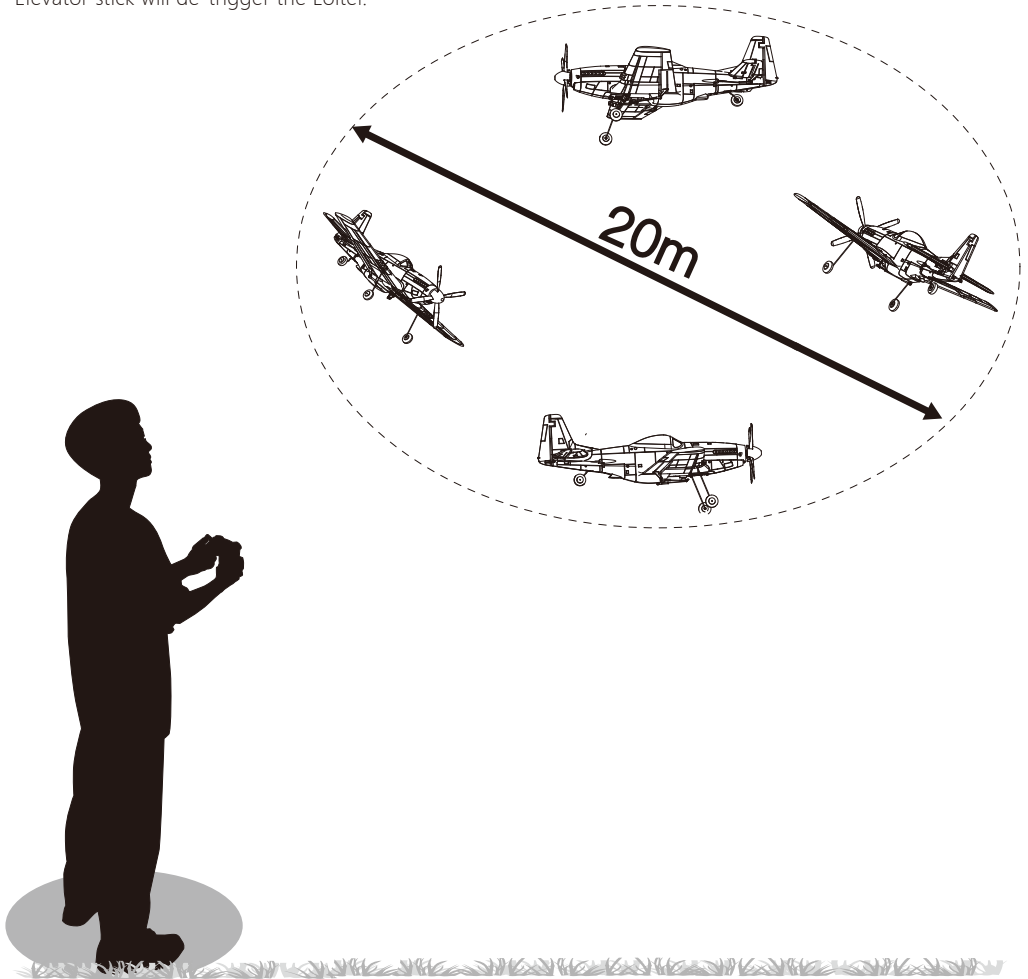

Binding Procedure

Power on the plane, the LED in the Control board will flash, then power on the transmitter, if the LED in the Control board change to solid, means the binding was finished. If the LED in the Control board is still flashing, means the binding failed, please do the above mentioned procedure again. Note: if the throttle stick is not in the lowest position (0 position) when you are binding, you have to move the throttle stick back to lowest position then move it to the top, and then back to the bottom, and then the throttle will be enabled.

Binding Procedure for “Mini SFHSS Sbus Receiver”

For FTR version the Sbus Receiver is pre-plugged into the control board, if you use other SFHSS radio instead of the existing radio, follow below steps:

1. Power on the control board.
2. Press the black button in the Sbus Receiver for 2 seconds; it's LED will flash quick.
3. Power on the SFHSS radio, if the Sbus Receiver LED stops flashing, means the binding was finished.

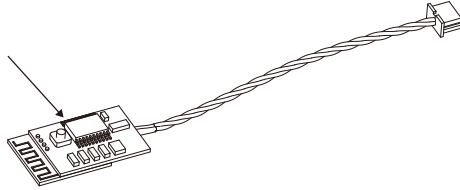

Mode 2 shown

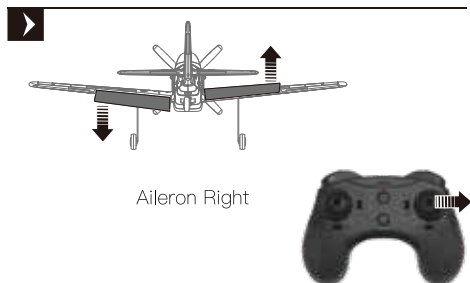
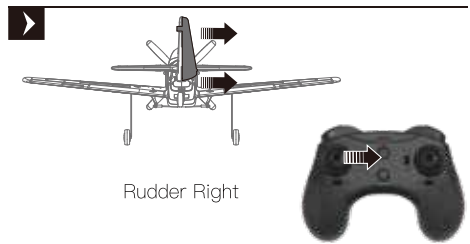
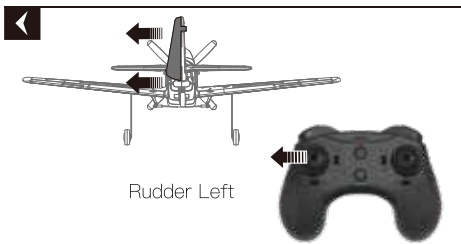
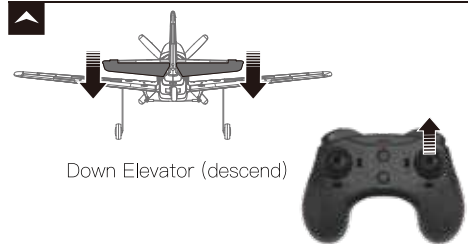
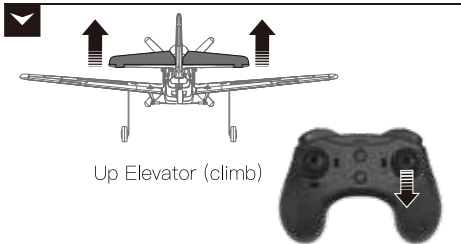

Take off Hand Launch

Use the 6G mode for takeoff in first flights. Get help to hand launch your aircraft so you can concentrate on flying. If you must hand launch the aircraft alone, hold the Aircraft in your dominant hand and the transmitter in your other hand.



Climbs at 100% throttle

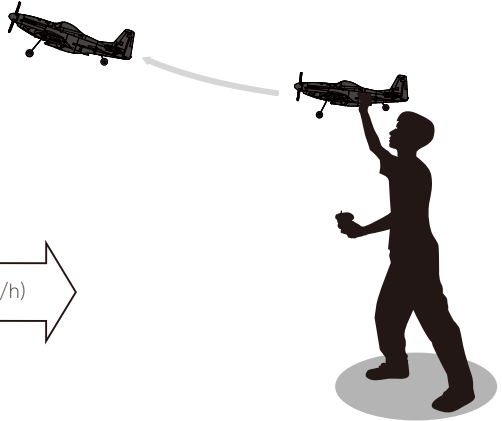
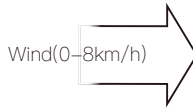

Ground Launch

- Take off from a hard and level runway.
- Use the rudder control to keep the aircraft rolling straight.
- Turn the aircraft only after it is high off the ground.



Gently pull back on the elevator stick to lift off of the ground.

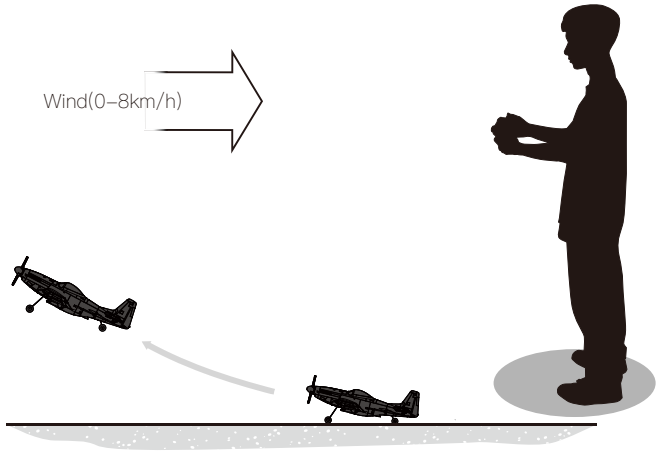
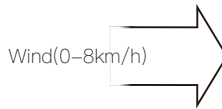

Flying

In 6G mode, when properly trimmed, your aircraft will climb at full throttle without use of the elevator stick.

- Try to fly the first few times for about 6 minutes to know more about the flying capability.
- If the motor pulses, land the aircraft immediately and recharge the flight battery.
- Flying with the nose pointed toward you is one of the hardest things to do when learning to fly. To practice piloting the aircraft, try flying in large circles high off the ground.

Landing

Fly to your runway, keeping the aircraft pointed into the wind and the wings level. Bring the aircraft down by lowering the throttle to 25%. Near the ground, fully lower the throttle and pull back on the steering stick.

CAUTION: Never catch a flying aircraft in your hands. Doing so could cause personal injury and damage to the aircraft.

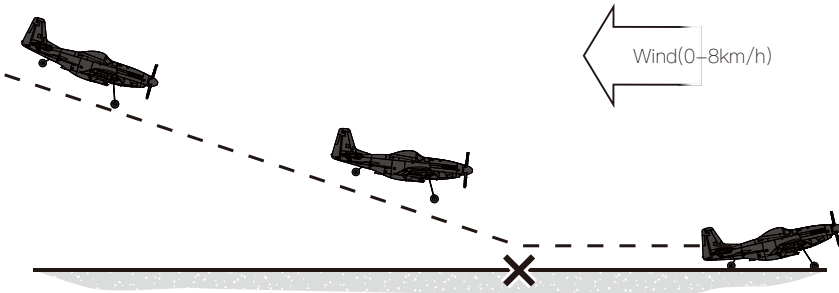

After Flying

1. Lower the throttle stick completely and do not move the steering stick. Wait at least 5 seconds.
2. Disconnect and remove the battery from the aircraft. Keep hands away from the propeller.
3. Power off the transmitter.
4. Fully charge the aircraft battery.
5. Remove the battery after charging is complete.

NOTICE: When you are finished flying, never leave the aircraft in direct sunlight or in a hot, enclosed area such as a car. Doing so can damage the foam.

NOTICE: Always disconnect the battery from the aircraft before powering off the transmitter or injury and damage may result.

REPAIRS

Repair this aircraft using foam-compatible CA (cyanoacrylate adhesive) glue or clear tape.

Only use foam-compatible CA glue as other types of glue can damage the foam.

NOTICE: Use of foam-compatible CA accelerant on your aircraft can damage paint. DO NOT handle the aircraft until the accelerant fully dries.

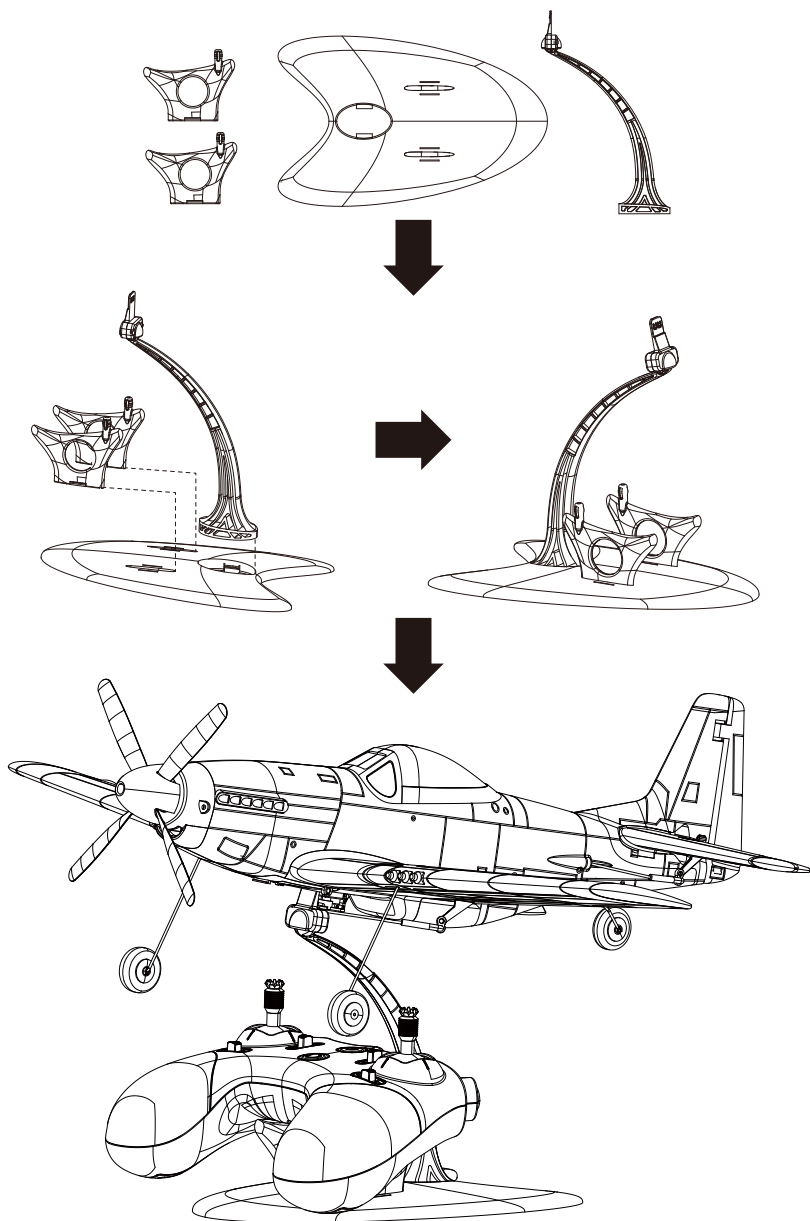



MADE IN CHINA

