

PLANE PRINT

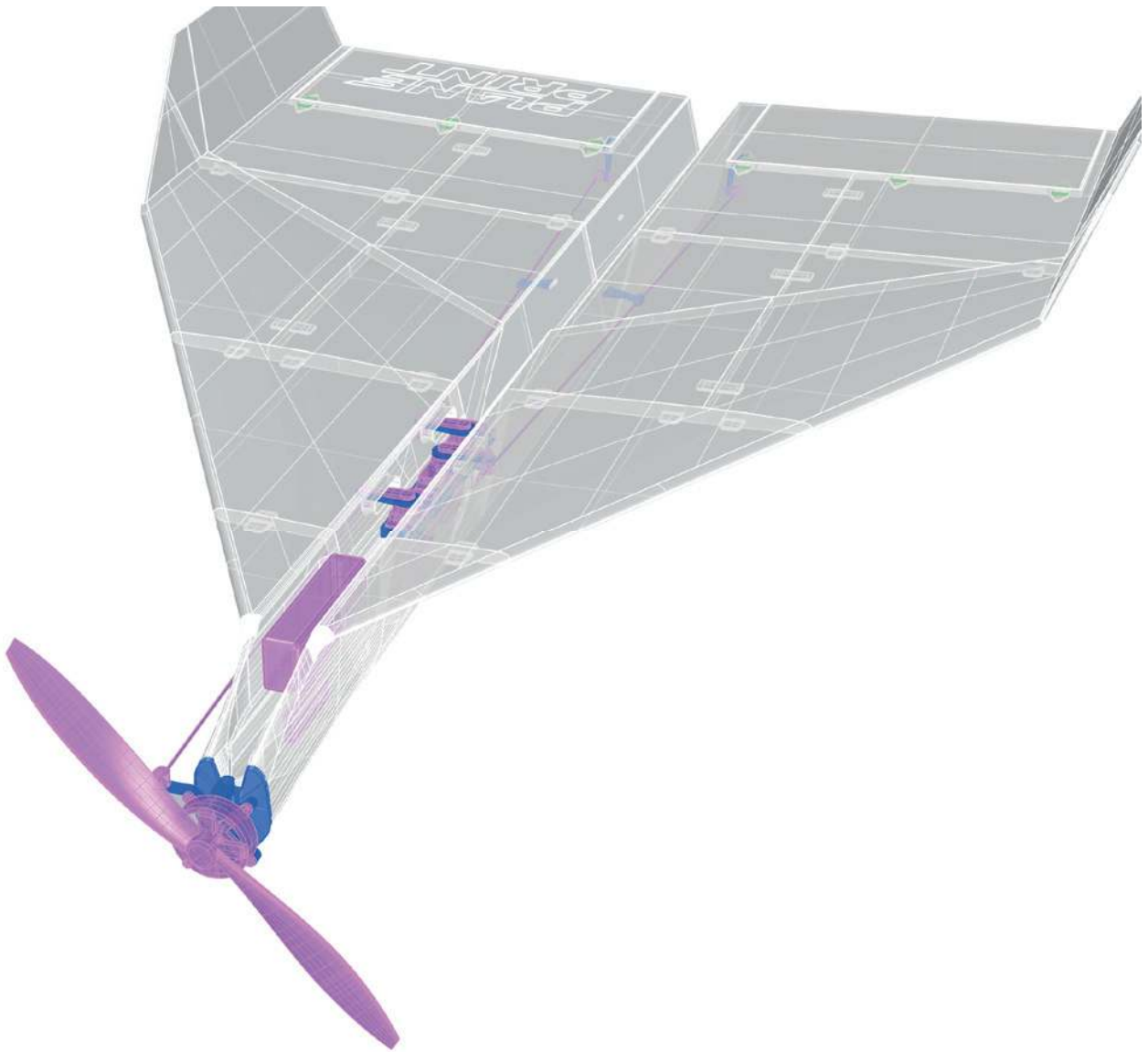

PLANE paper
PRINT plane



NOTE:
Slicing works best
with CURA!



www.planeprint.com

the **ONLY** place where you can get
original Planeprint STL files **legally!**

PLANE PRINT paper plane

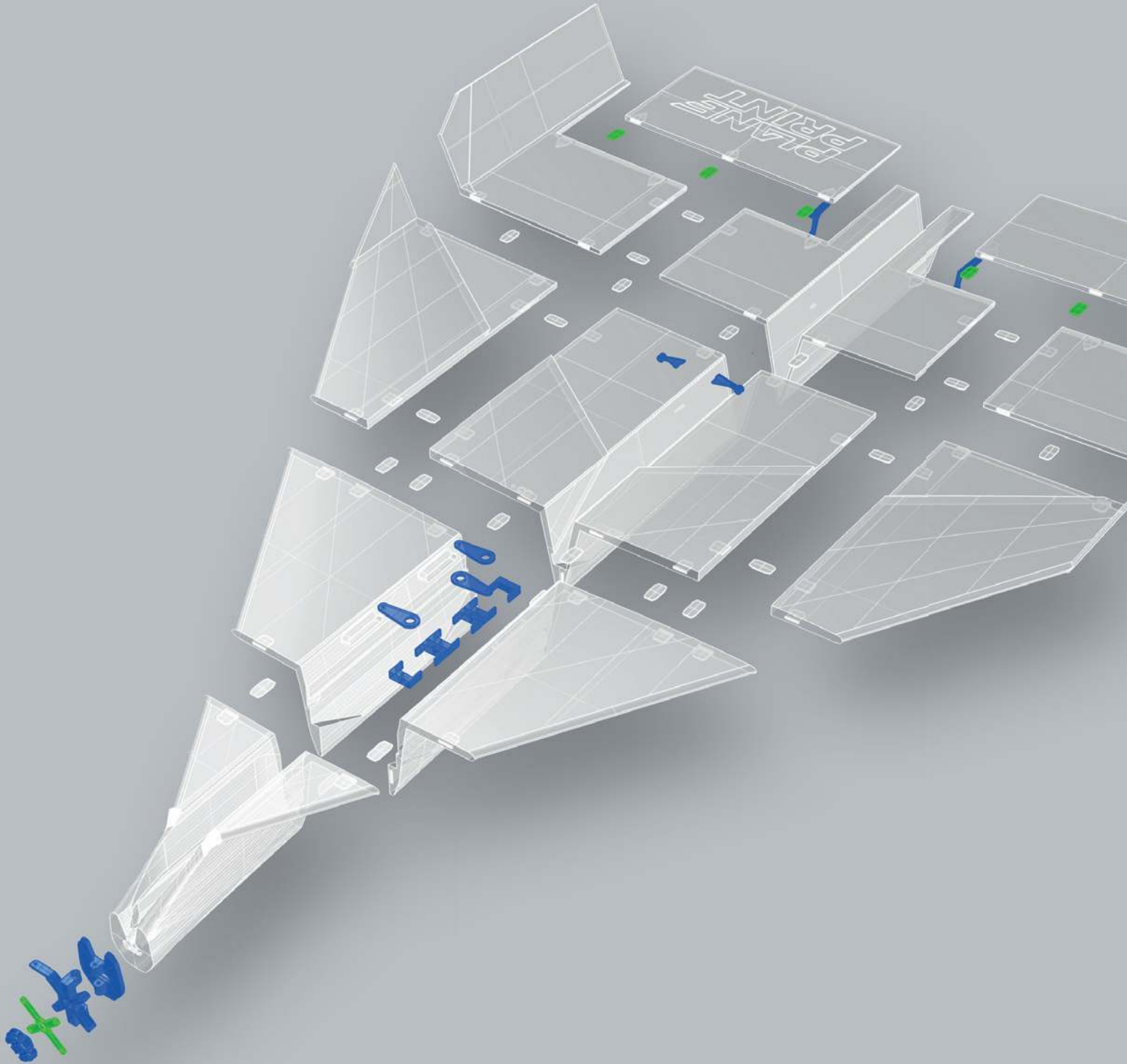

RC Components

MOTOR AXI 2203/40 VPP or comparable indoor-20 grams-motors.

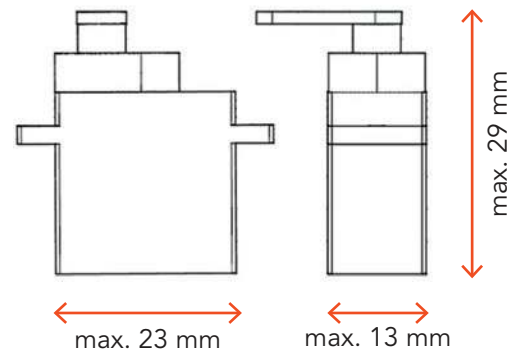
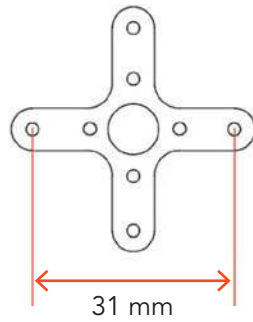

PROP 8x3.8, 8x4.3 or comparable (not the soft indoor props)

BEC-CONTROLLER 15 A (one matching the motor)

RECEIVER 4 Channel

BATTERY 2S Lipo, 900 MaH (ideal weight 45 g, maximum thickness 18 mm, maximum height 30 mm)

SERVOS Hitec HS-55 or similar, 3 pieces

Required accessoires – basic equipment

Links to recommended accessories can be found on www.planeprint.com/paper (scroll down)

- LW-PLA (**cannot be replaced by PLA!**), ~220 grams
- PLA oder better Tough PLA, ~20 grams
- TPU A95, ~5 grams
- some tapping screws
- CA super glue (liquid and medium)
- CA activator
- Carbon rod Ø1.5*1000mm, 1 piece
- Rod connection 2mm, 6 pieces
- Self adhesive velcro tape

Tools

Cutter knife, small Philips screwdriver, Sandpaper, Needle nose pliers



Tapping screws 2mm



Rod connection hole 2mm



The development of a complex, airworthy RC flight model to express on any standard 3D printer is a very extensive process. **Therefore, we appeal to your fairness not to forward the STL data you have acquired to third parties.**

Thank you for your understanding and have fun with your PLANEPRINT MODEL!

Printing the parts – Printing profiles

This manual is constantly being improved and supplemented, we recommend downloading the **latest version** from our website **before building**.

To print all **PLANEPRINT** models you need to set some basic profiles in Cura (If you use another slicer, please set the same parameters).

You can find the description at www.planepprint.com/print

For this model you need the following profiles:

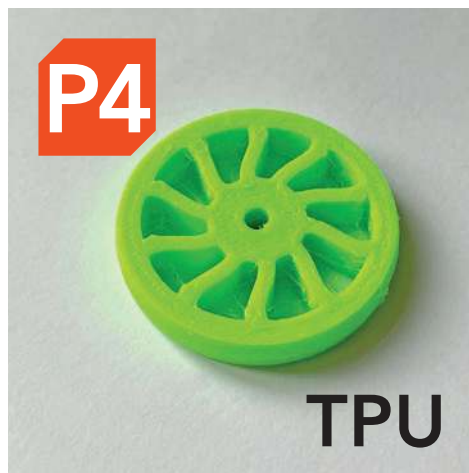

PROFILE P5_Gyroid

It is **essential for the necessary stability** of the **LW parts printed with PROFILE_5 are as stable as possible**. Please use a test part to check the strength by fracture tests. It must not break along the layer lines under any circumstances! Also note that the printing temperature for LW-PLA is as low as possible to obtain a wall thickness of 0.4 to 0.6 mm at a flow of 60 to 70 % (depending on brand).

Caution: at too high temperatures, LW-PLA becomes brittle and breaks more easily.



PROFILE P1_Fullbody PLA or Tough PLA



The following parts should be sliced with the PROFILE P1_Fullbody.
Please note the additional settings for the individual parts!

P1_Interconnects_pp.stl

MATERIAL PLA, Weight: ~ 3 g

ADDITIONAL SETTINGS

None required

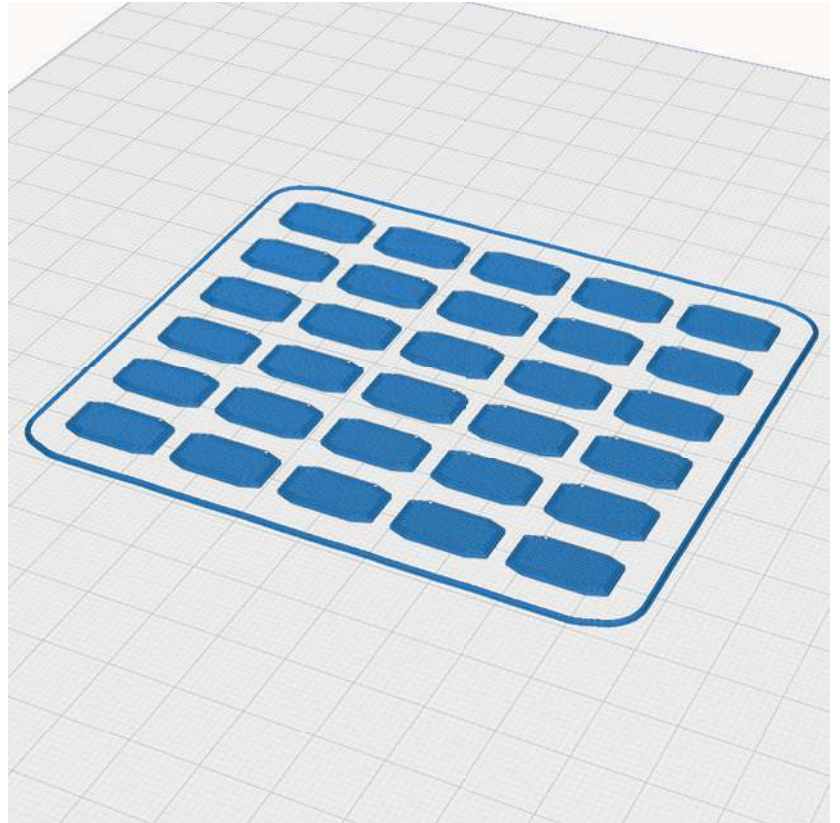

P1_Motor mount_pp.stl

MATERIAL PLA, Weight: ~ 5 g

ADDITIONAL SETTINGS

None required

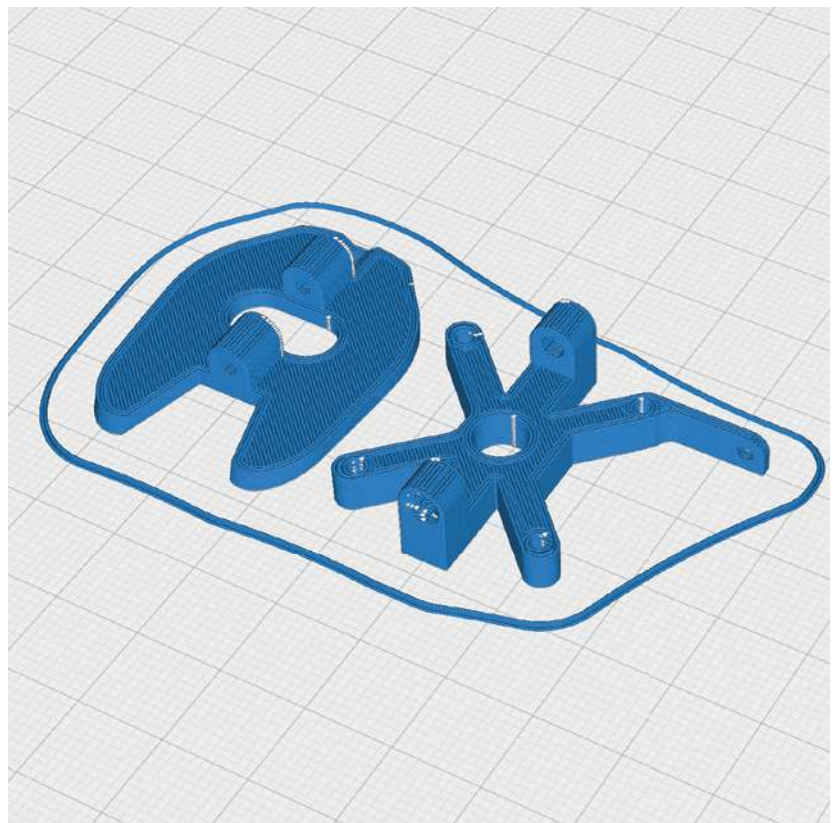

PROFILE P1_Fullbody PLA or Tough PLA



The following parts should be sliced with the PROFILE P1_Fullbody.
Please note the additional settings for the individual parts!

P1_Parts_pp.stl

MATERIAL PLA, Weight: ~ 2 g

ADDITIONAL SETTINGS

None required

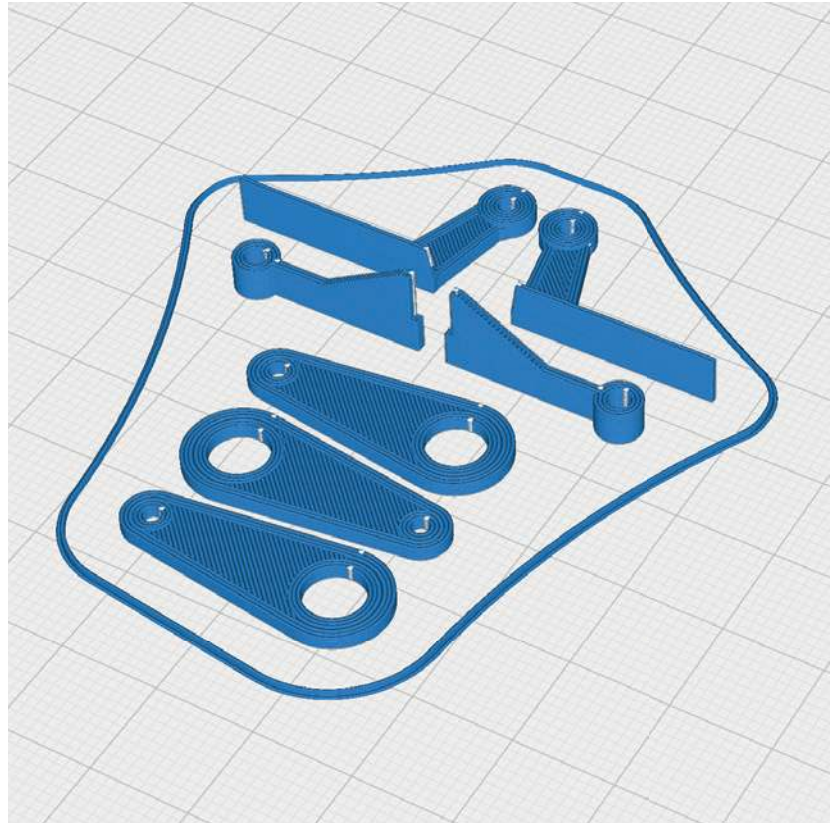

P1_Servo mount_pp.stl

MATERIAL PLA, Weight: ~ 3 g

ADDITIONAL SETTINGS

None required

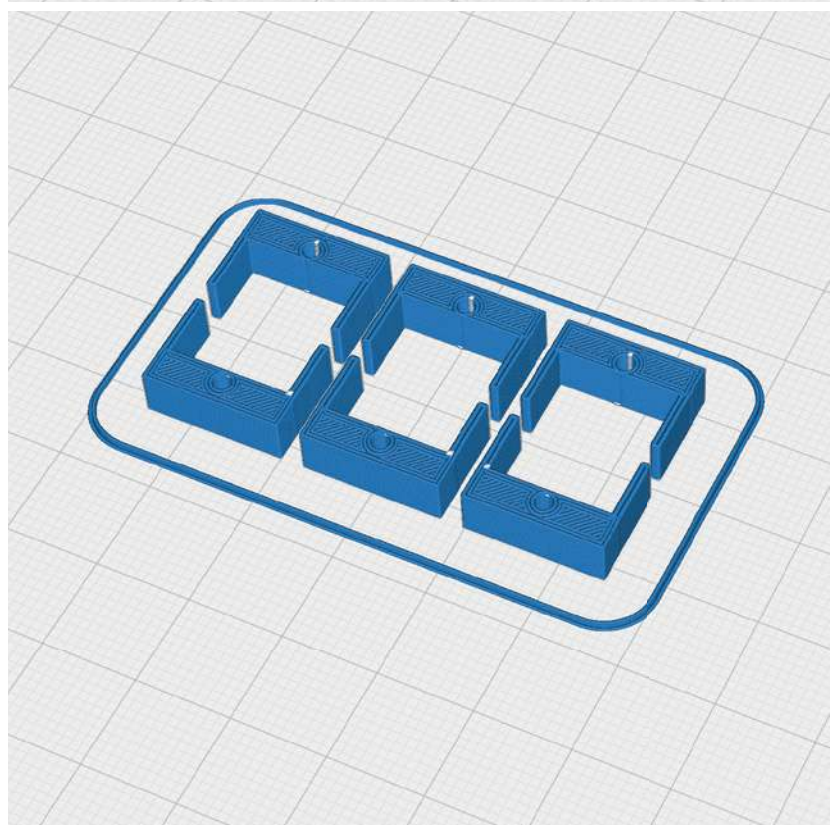

PROFILE P1_Fullbody PLA or Tough PLA



The following parts should be sliced with the PROFILE P1_Fullbody.
Please note the additional settings for the individual parts!

P1_Spinner_pp.stl

MATERIAL PLA, Weight: ~ 3 g

ADDITIONAL SETTINGS

None required

You can **optionally** use the spinner to increase the tension of the rubber band for the prop. Try which spinner fits better on your prop.

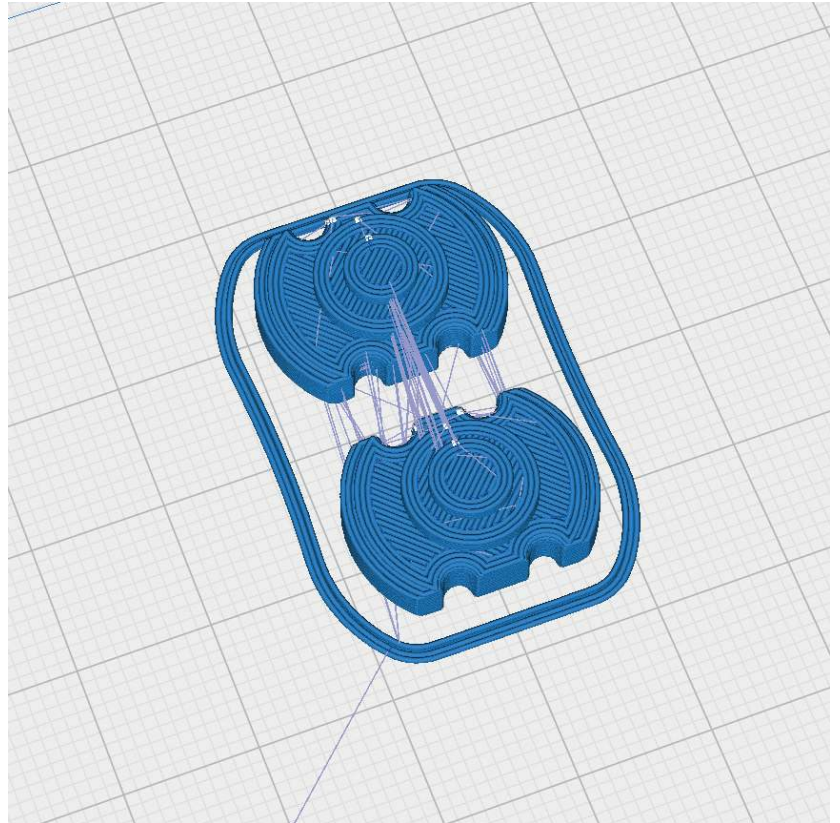
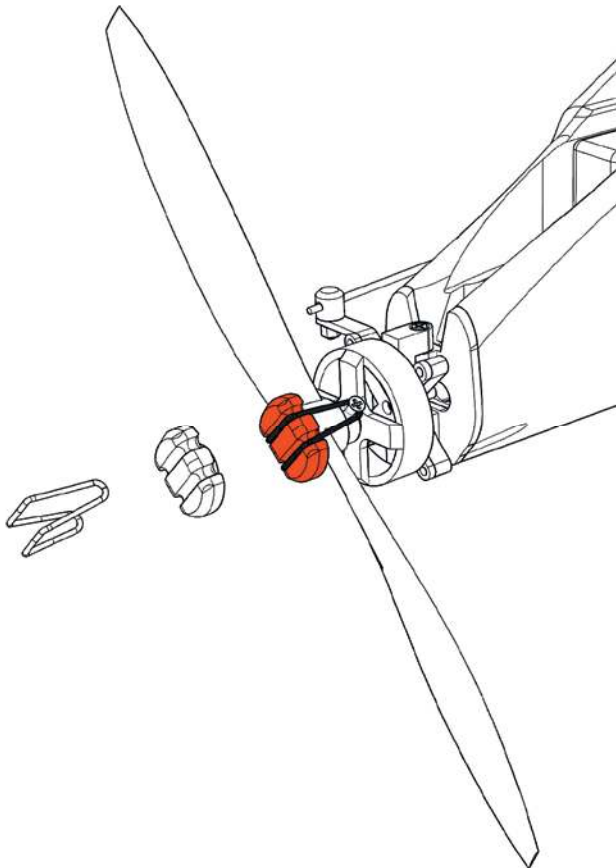

PROFILE P4_Flex



The following parts should be sliced with the PROFILE P4_Flex.
Please note the additional settings for the individual parts!

P4_TPU-Parts_pp.stl

MATERIAL TPU A95, Weight: ~ 2 g

ADDITIONAL SETTINGS

- Infill Density: 100 %

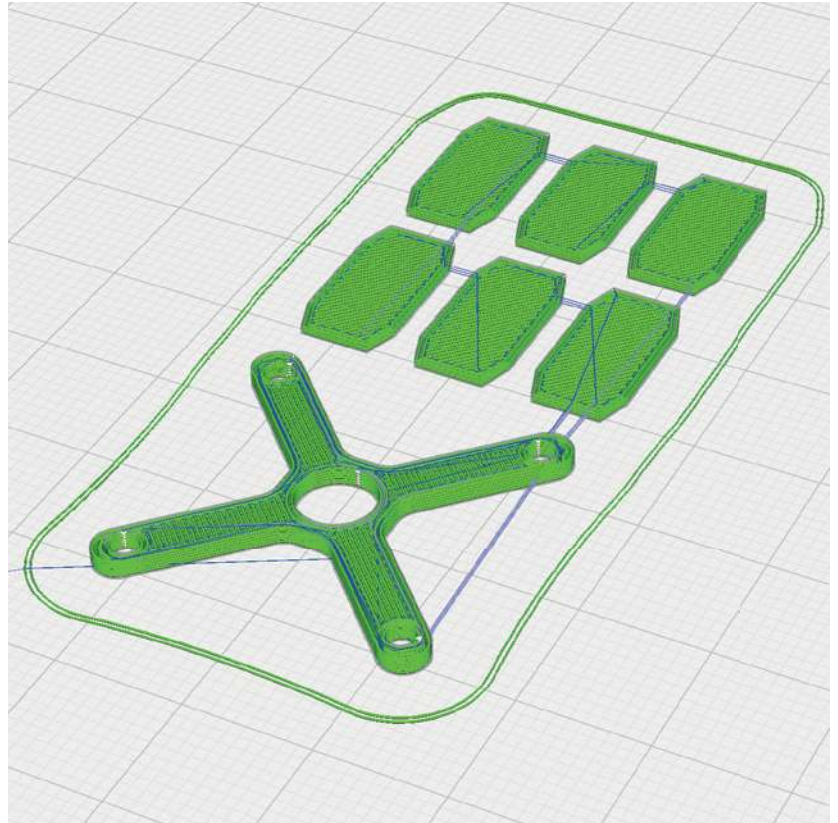

PROFILE P5_Gyroid **Light-Weight LW-PLA!**



The following parts must be sliced with the PROFILE P5_Gyroid. **Please note the additional settings for the individual parts! It is essential to print these parts with LW-PLA!**

Basic settings for LW-PLA: Please follow the instructions in our **WINGTEST AND CALIBRATION TOOL** on our website for correct adjustment!

P5_Aileron L_pp.stl

MATERIAL LW-PLA, ~ 11 g*

*Weighed (approximate guideline)

ADDITIONAL SETTINGS

None required

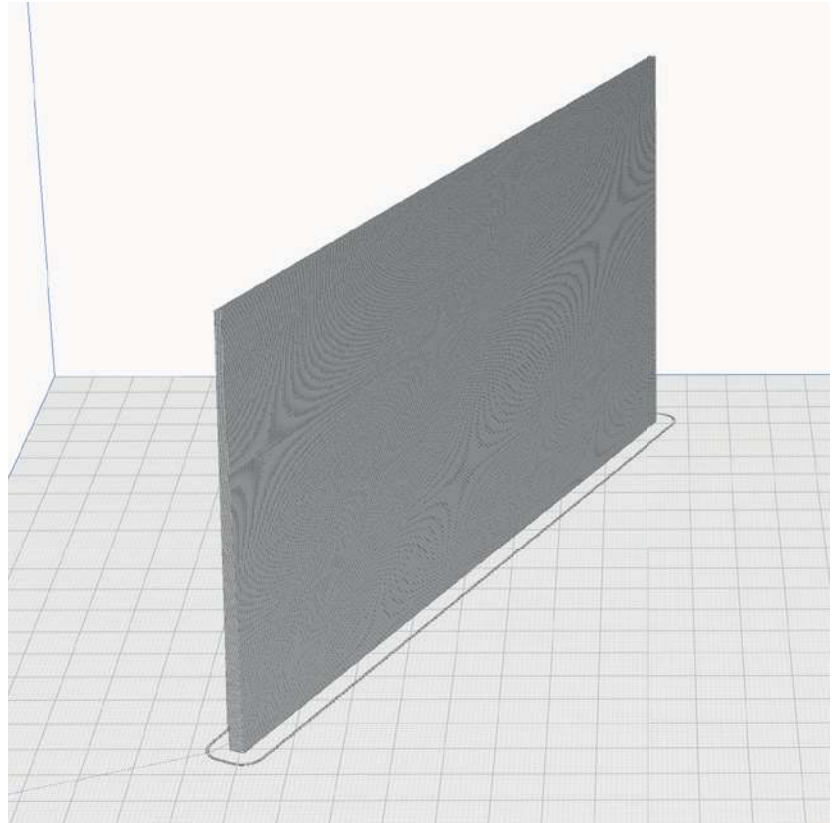

P5_Aileron R_pp.stl

MATERIAL LW-PLA, ~ 11 g*

*Weighed (approximate guideline)

ADDITIONAL SETTINGS

None required

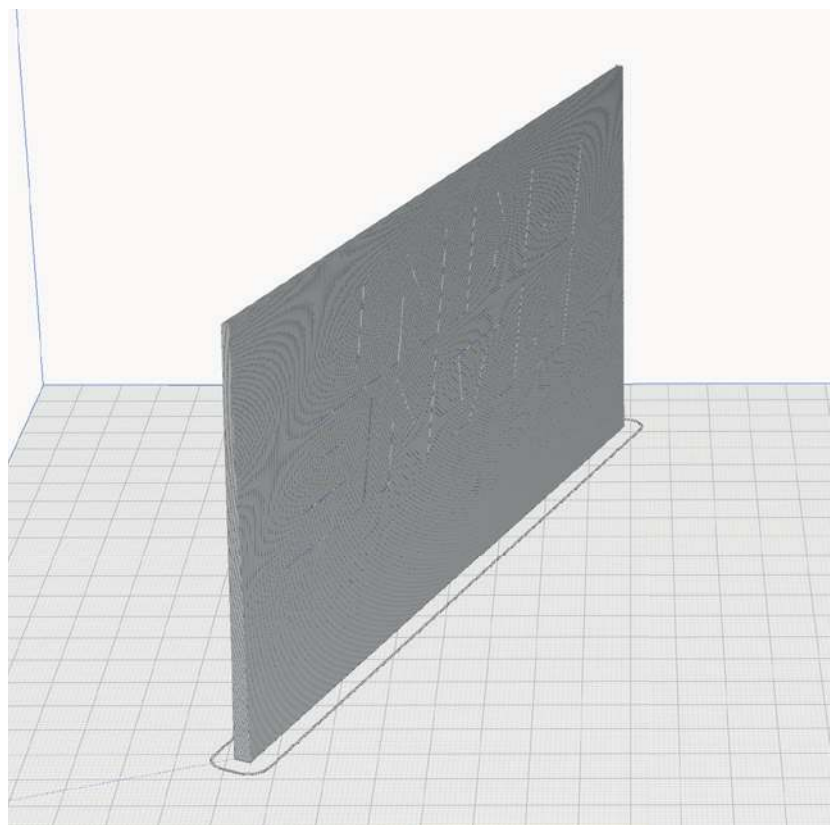

PROFILE P5_Gyroid Light-Weight LW-PLA!



The following parts must be sliced with the PROFILE P5_Gyroid. **Please note the additional settings for the individual parts! It is essential to print these parts with LW-PLA!**

Basic settings for LW-PLA: Please follow the instructions in our **WINGTEST AND CALIBRATION TOOL** on our website for correct adjustment!

P5_Delta 1_pp.stl

MATERIAL LW-PLA, ~ 25 g*

*Weighed (approximate guideline)

ADDITIONAL SETTINGS

- Wall Line Count: 2

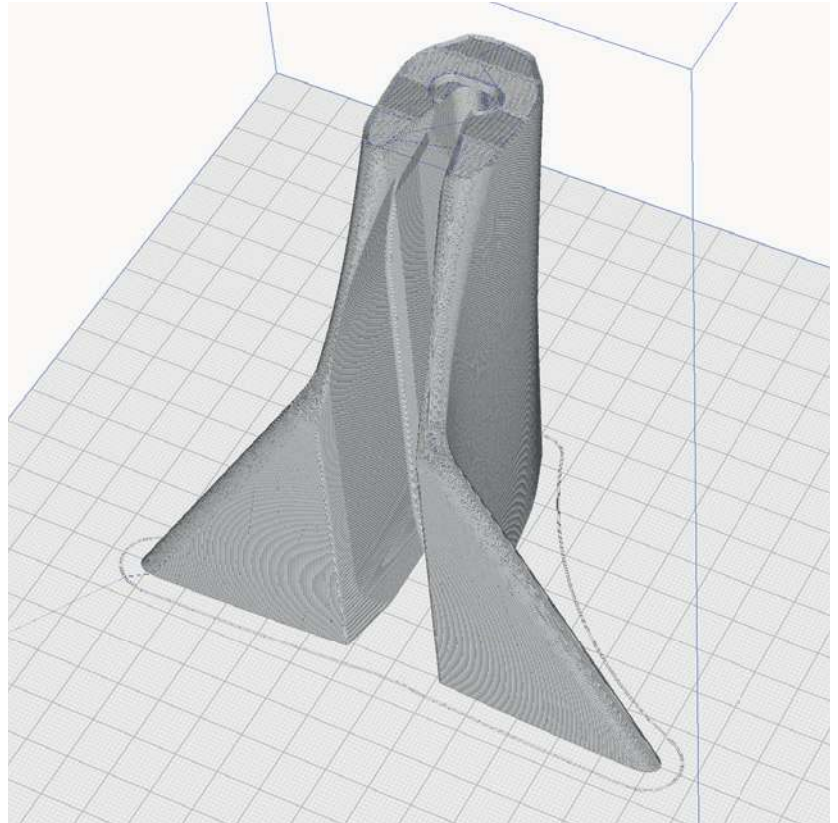

P5_Delta 2 L_pp.stl

MATERIAL LW-PLA, ~ 17 g*

*Weighed (approximate guideline)

ADDITIONAL SETTINGS

None required

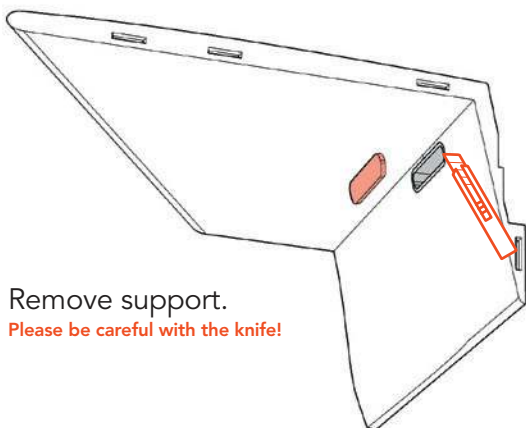

Remove support.
Please be careful with the knife!

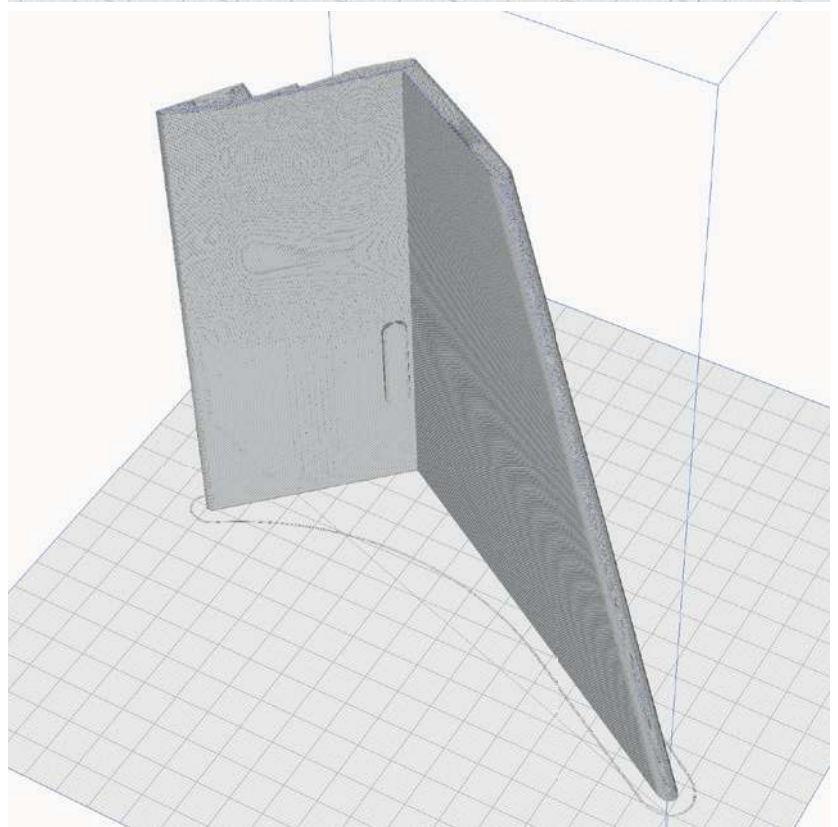

PROFILE P5_Gyroid Light-Weight LW-PLA!



The following parts must be sliced with the PROFILE P5_Gyroid. **Please note the additional settings for the individual parts! It is essential to print these parts with LW-PLA!**

Basic settings for LW-PLA: Please follow the instructions in our **WINGTEST AND CALIBRATION TOOL** on our website for correct adjustment!

P5_Delta 2 R_pp.stl

MATERIAL LW-PLA, ~ 17 g*

*Weighed (approximate guideline)

ADDITIONAL SETTINGS

None required

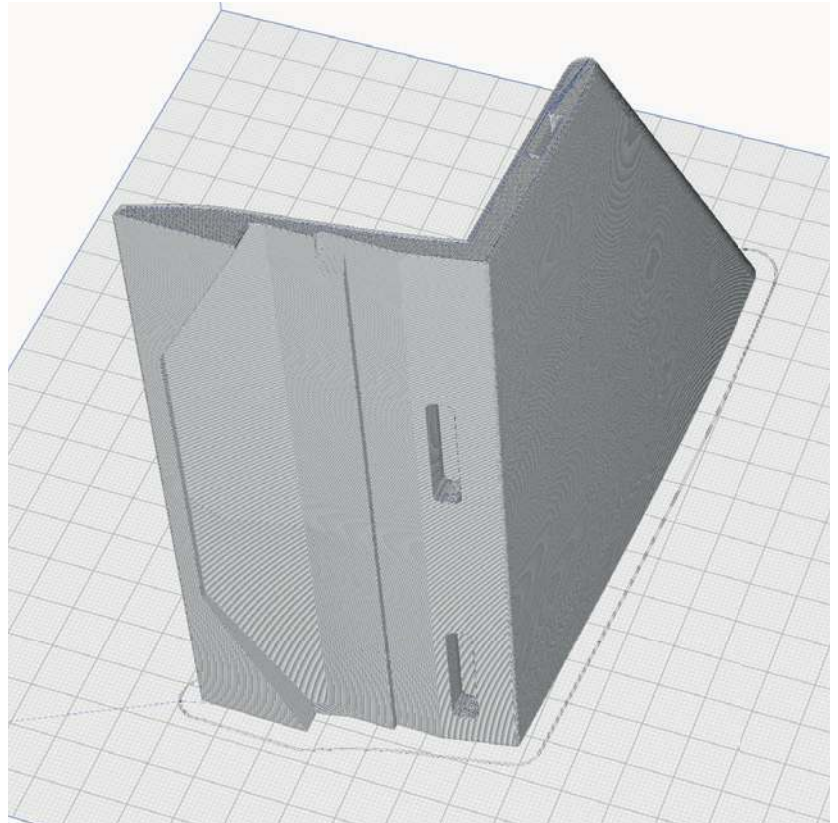
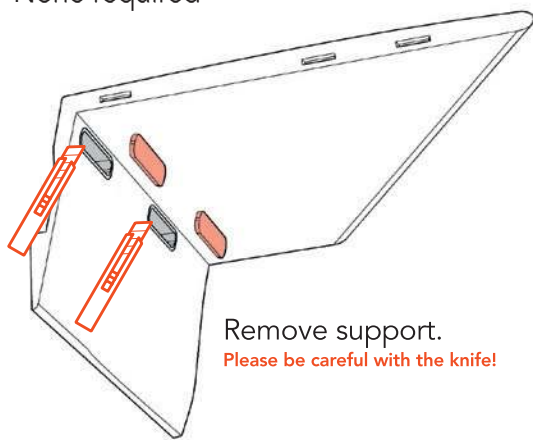

P5_Delta 3 L_pp.stl

MATERIAL LW-PLA, ~ 18 g*

*Weighed (approximate guideline)

ADDITIONAL SETTINGS

None required

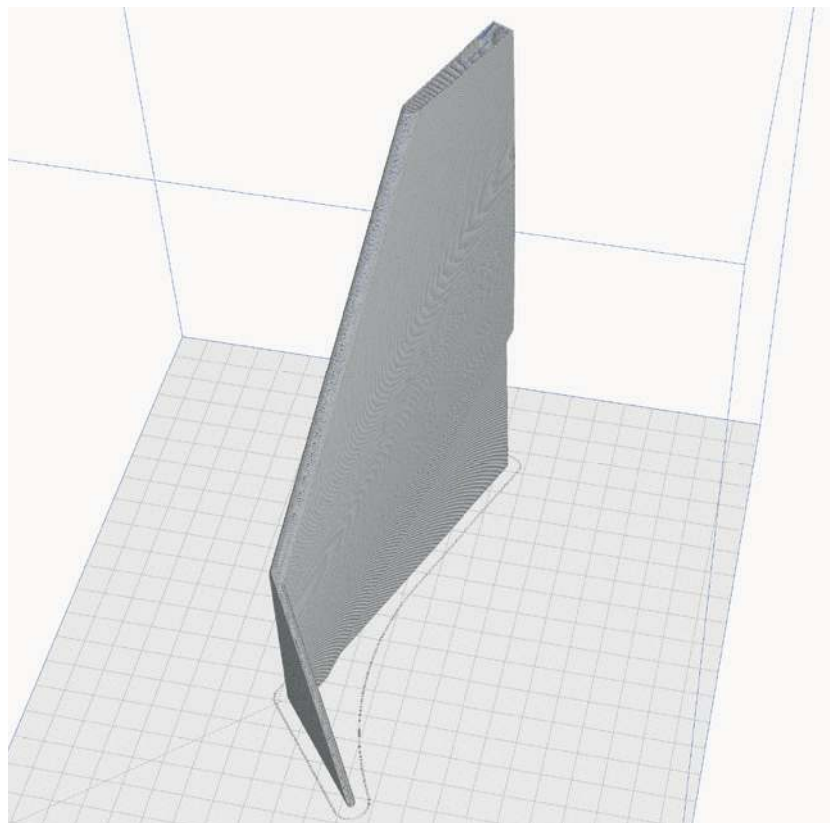

PROFILE P5_Gyroid Light-Weight LW-PLA!



The following parts must be sliced with the PROFILE P5_Gyroid. **Please note the additional settings for the individual parts! It is essential to print these parts with LW-PLA!**

Basic settings for LW-PLA: Please follow the instructions in our **WINGTEST AND CALIBRATION TOOL** on our website for correct adjustment!

P5_Delta 3 M_pp.stl

MATERIAL LW-PLA, ~ 40 g*

*Weighed (approximate guideline)

ADDITIONAL SETTINGS

None required

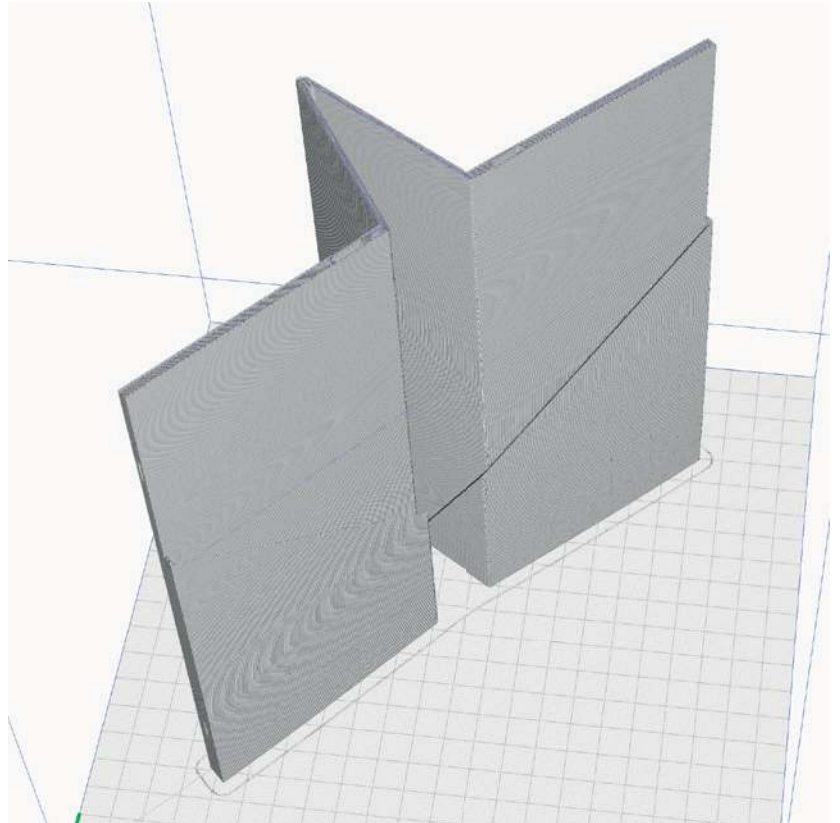

P5_Delta 3 R_pp.stl

MATERIAL LW-PLA, ~ 18 g*

*Weighed (approximate guideline)

ADDITIONAL SETTINGS

None required

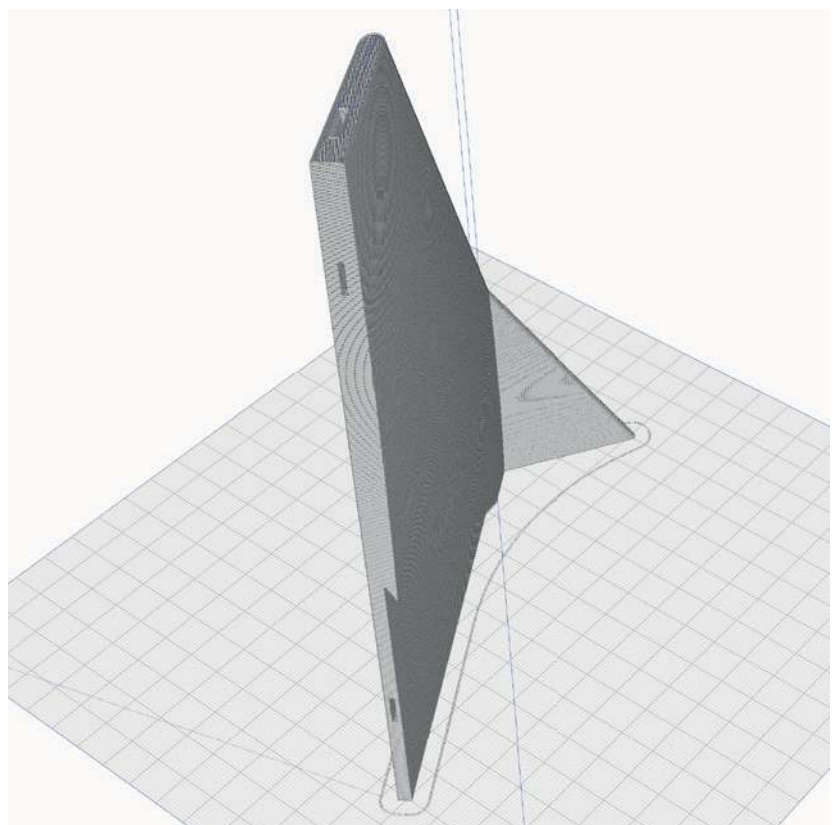

PROFILE P5_Gyroid **Light-Weight LW-PLA!**



The following parts must be sliced with the PROFILE P5_Gyroid. **Please note the additional settings for the individual parts! It is essential to print these parts with LW-PLA!**

Basic settings for LW-PLA: Please follow the instructions in our **WINGTEST AND CALIBRATION TOOL** on our website for correct adjustment!

P5_Delta 4 L_pp.stl

MATERIAL LW-PLA, ~ 17 g*

*Weighed (approximate guideline)

ADDITIONAL SETTINGS

None required

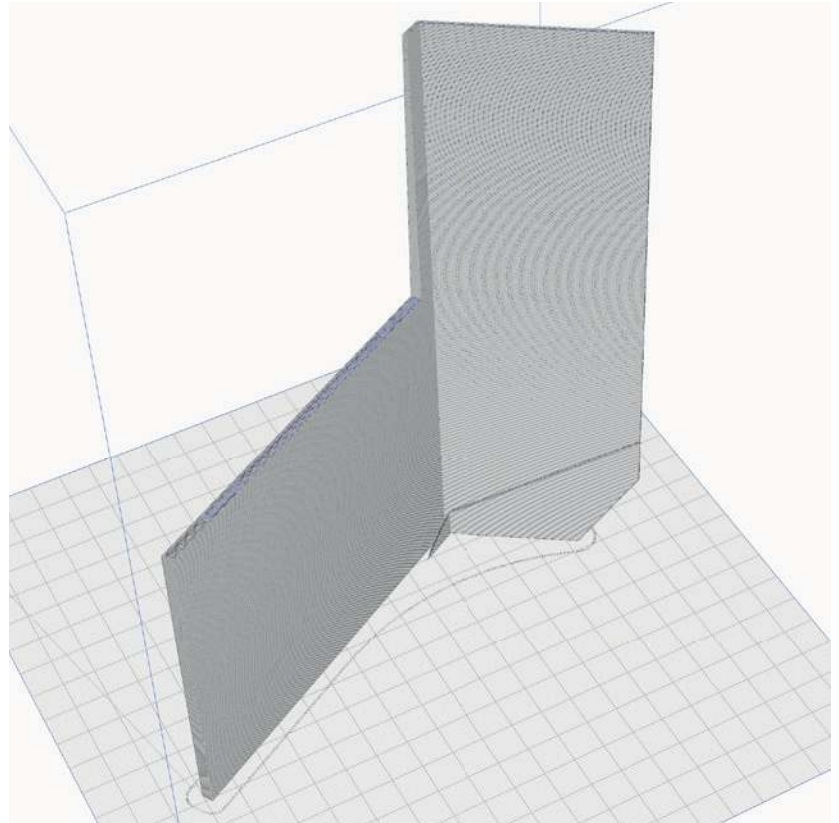

P5_Delta 4 M_pp.stl

MATERIAL LW-PLA, ~ 29 g*

*Weighed (approximate guideline)

ADDITIONAL SETTINGS

None required

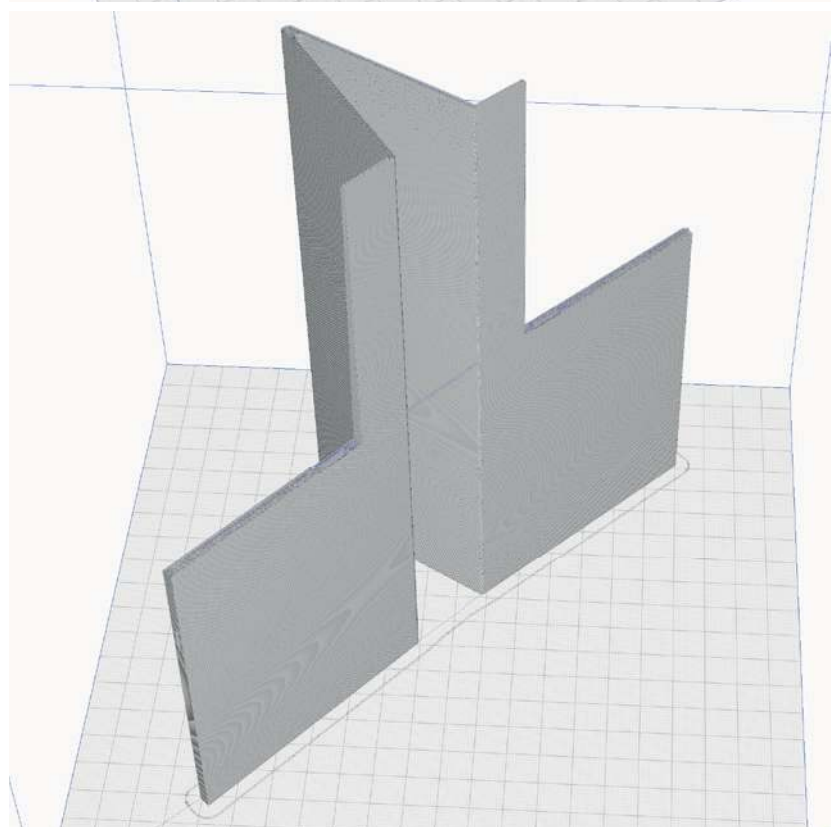

PROFILE P5_Gyroid Light-Weight LW-PLA!



The following parts must be sliced with the PROFILE P5_Gyroid. **Please note the additional settings for the individual parts! It is essential to print these parts with LW-PLA!**

Basic settings for LW-PLA: Please follow the instructions in our **WINGTEST AND CALIBRATION TOOL** on our website for correct adjustment!

P5_Delta 4 R_pp.stl

MATERIAL LW-PLA, ~ 17 g*

*Weighed (approximate guideline)

ADDITIONAL SETTINGS

None required

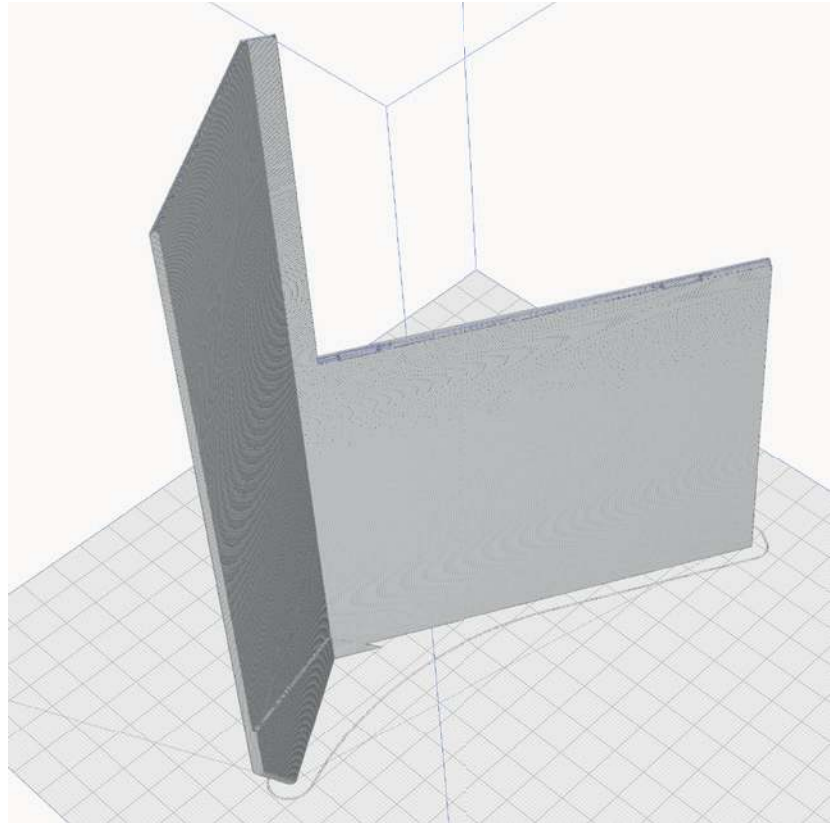

Basic Information:

Gluing the parts printed with PROFILE P5

- STEP 1** As a first step, it is important to **roughen and smooth the adhesive surfaces** with sandpaper.
- STEP 2** Insert the **interconnects into the slots** provided on one side.
- STEP 3** Apply a **lot of glue** to the side with the interconnects. It is important that there is glue everywhere, especially on the outside and inside of the wall surfaces, in order to achieve a perfect connection. The interconnects only serve to align the parts to each other. It is better **not** to apply glue here, otherwise it can happen that the glue suddenly hardens while the parts are being put together and stops the process.

Use **medium viscosity CA glue**, thinner glue would run down the parts too easily.

After assembly, **align the two parts exactly** and wipe off the excess CA glue from the surface with a cloth. Now spray with activator spray along the gluing surface and carefully press the parts together.

- STEP 4** Clean the glued areas slightly with a **sharp-bladed cutter**.



PROFILES 5 parts are easy to repair

- STEP 1** Using the knife, carefully remove the damaged part about 3 mm from the glue joint between two parts.
- STEP 2** Cut wall and infill and clean the surface with sandpaper. **The top surface of the damaged part remains!**
- STEP 3** The remaining top surface is about 1 mm thick. To compensate for this, you can move the new part to be printed down the Z axis in Cura by 1 mm.

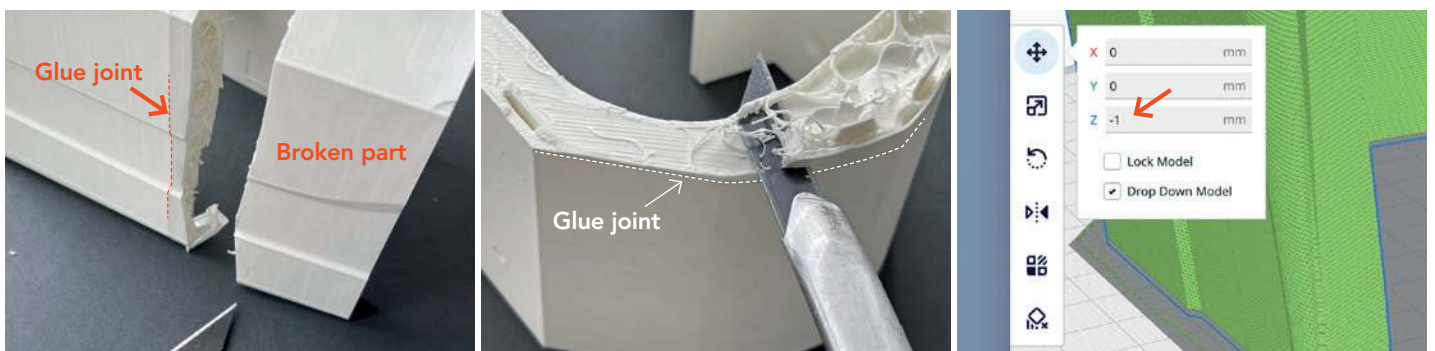

Delta assembly

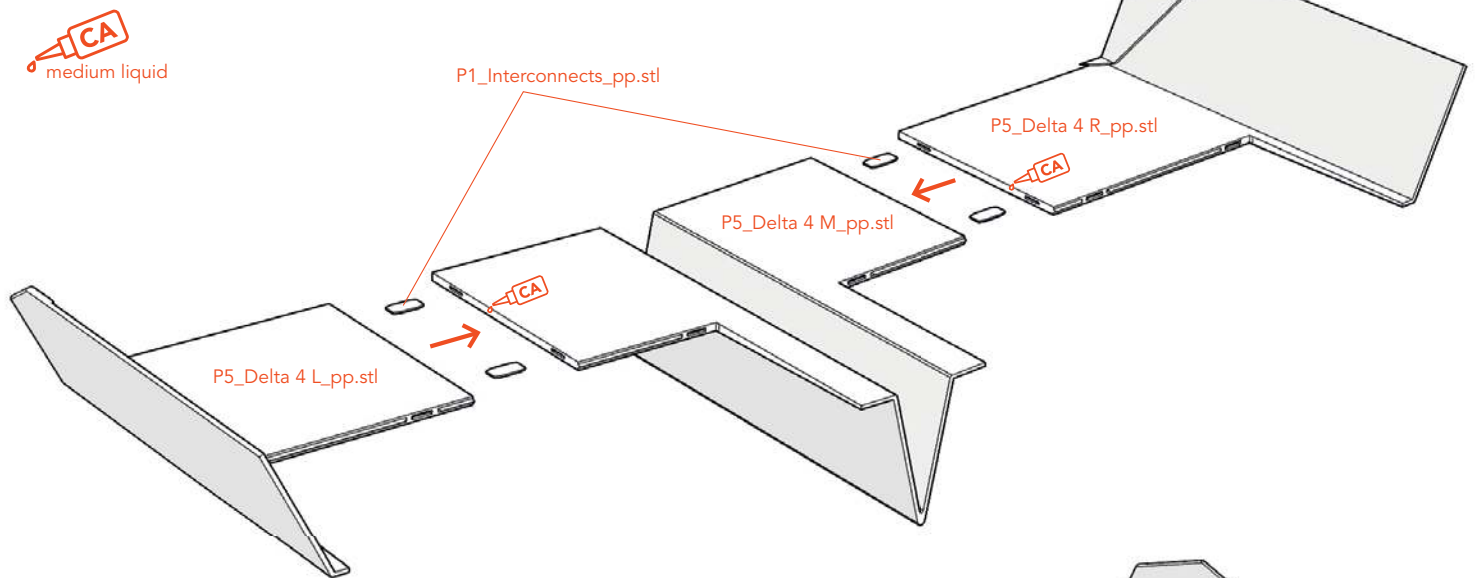

Aileron

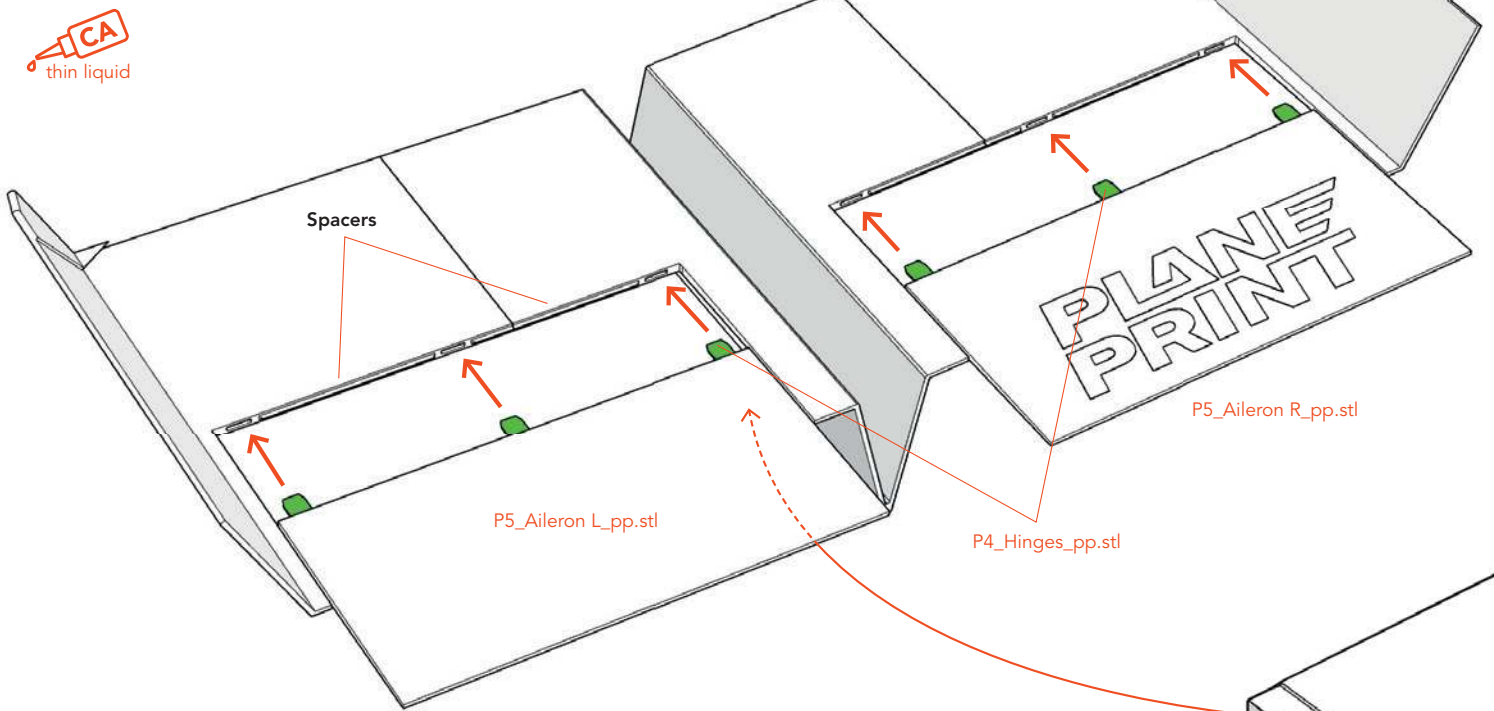

Installation the TPU Hinges

First insert the hinges into the **Ailerons** and add a drop of **liquid CA** adhesive into the gap. Wait for the glue to drain completely, then spray the activator on it.

Then put the Aileron in the Wing until **the Aileron touches the spacers** and put a drop of CA glue on the hinge. Wait again for the glue to run in, and then spray the activator on it.

NOTE The marking for the control horn must be down!

Do not use too much glue, the Ailerons must move easily!

Delta assembly

 medium liquid

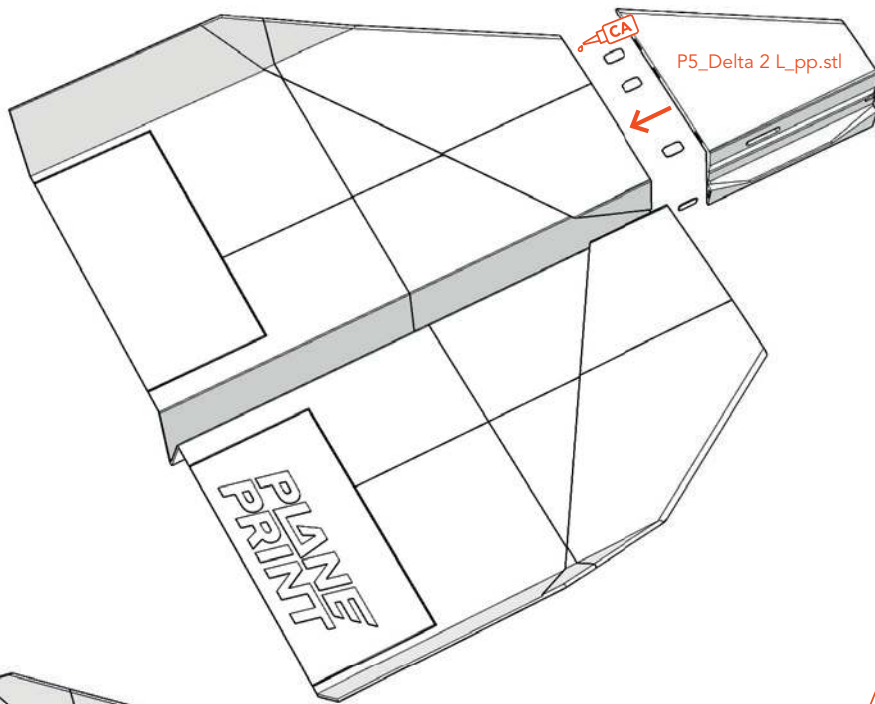
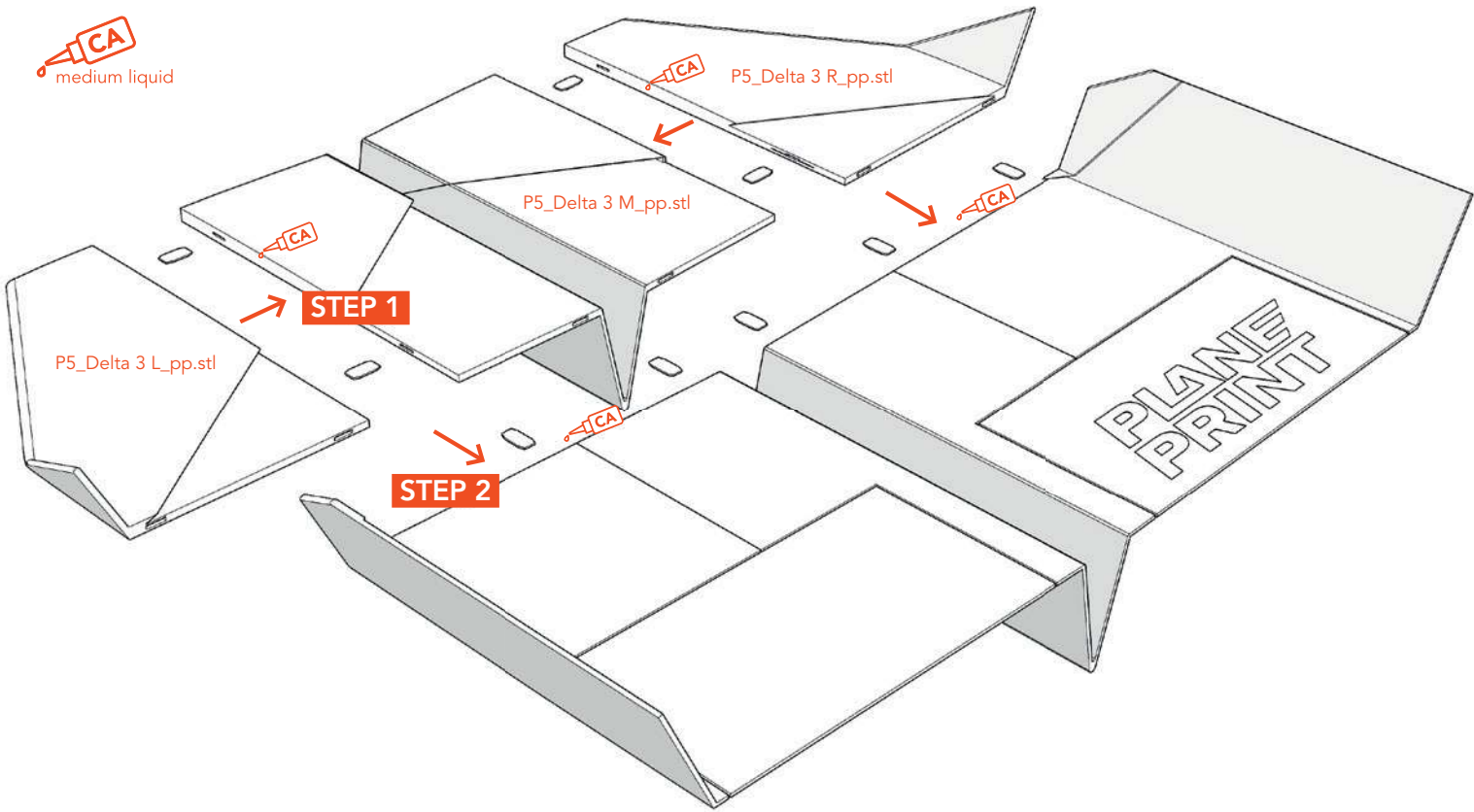

Servo mount

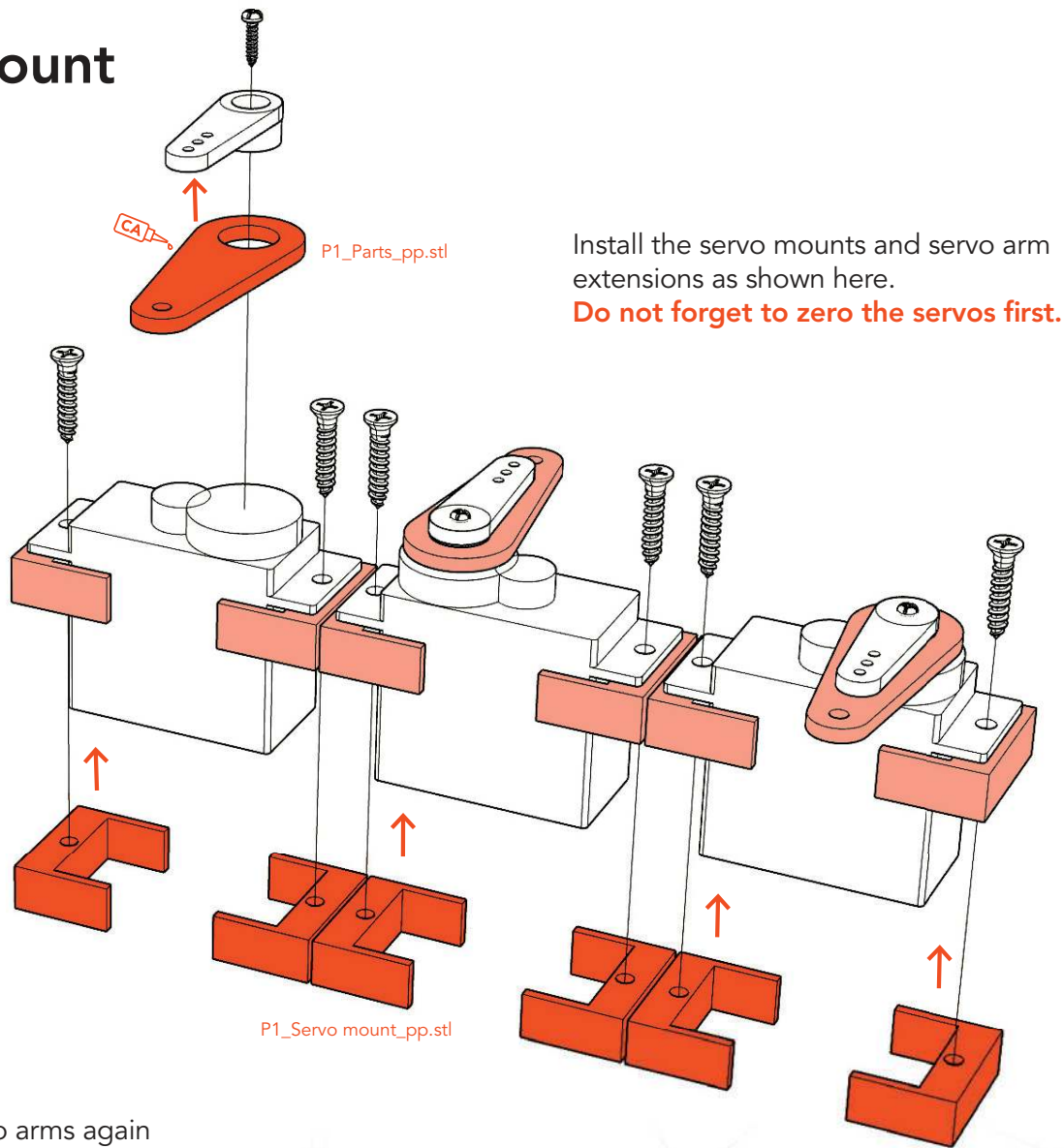

Install the servo mounts and servo arm extensions as shown here.
Do not forget to zero the servos first.

Unscrew the servo arms again and glue the servos into the fuselage and make sure that the axis of rotation is centered with the openings for the servo arms (also in height!).

If your servos have different dimensions and the servo brackets (P1_Servo mount_pp.stl) are too high, you can print them in Cura at the appropriate height by changing the dimension for the Z-axis.

If the servos are tight, you can mount the servo arms.

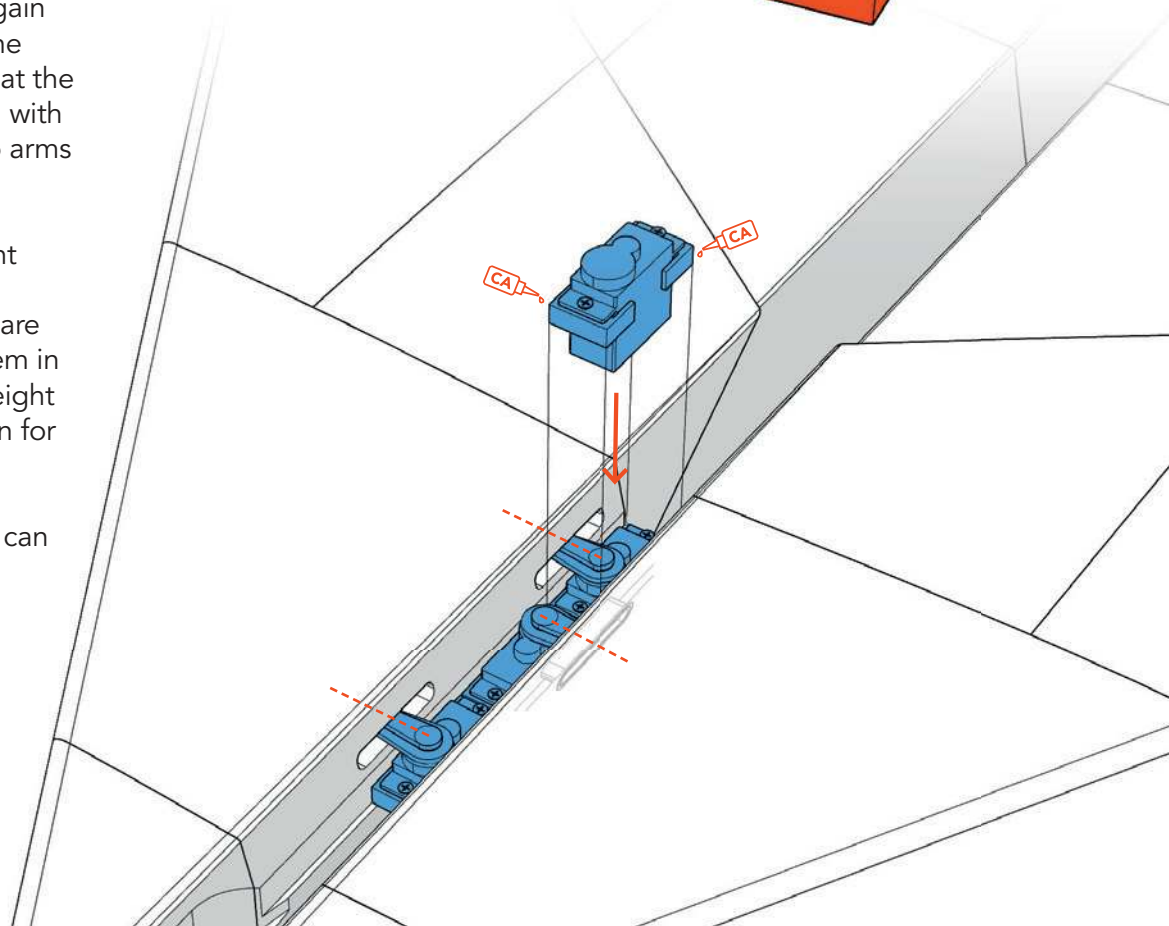

Servo mount Ailerons

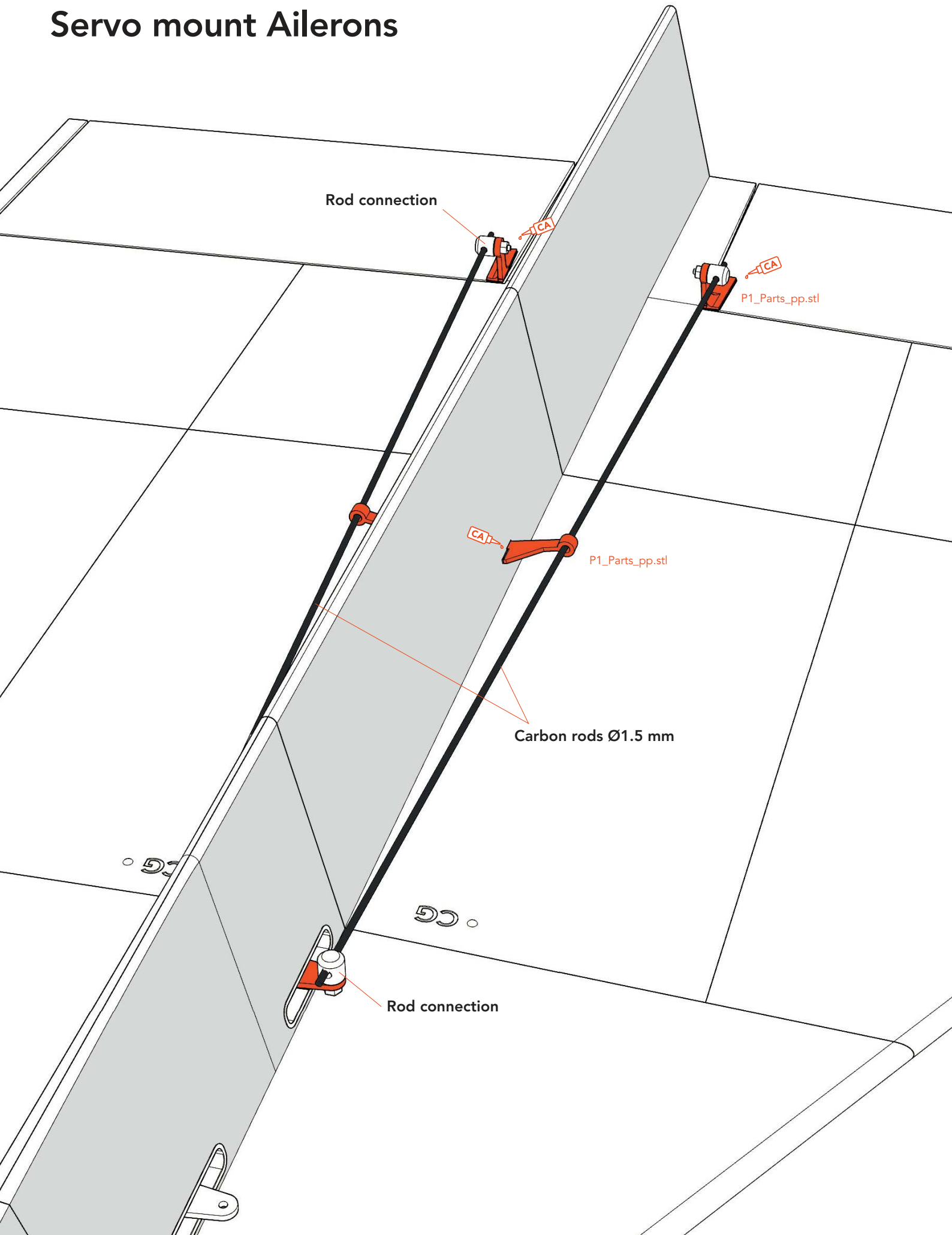

Motor mount

SAFETY FIRST Make sure the prop runs smoothly and does not generate vibrations. **Check regularly that the motor mounting is absolutely tight!**

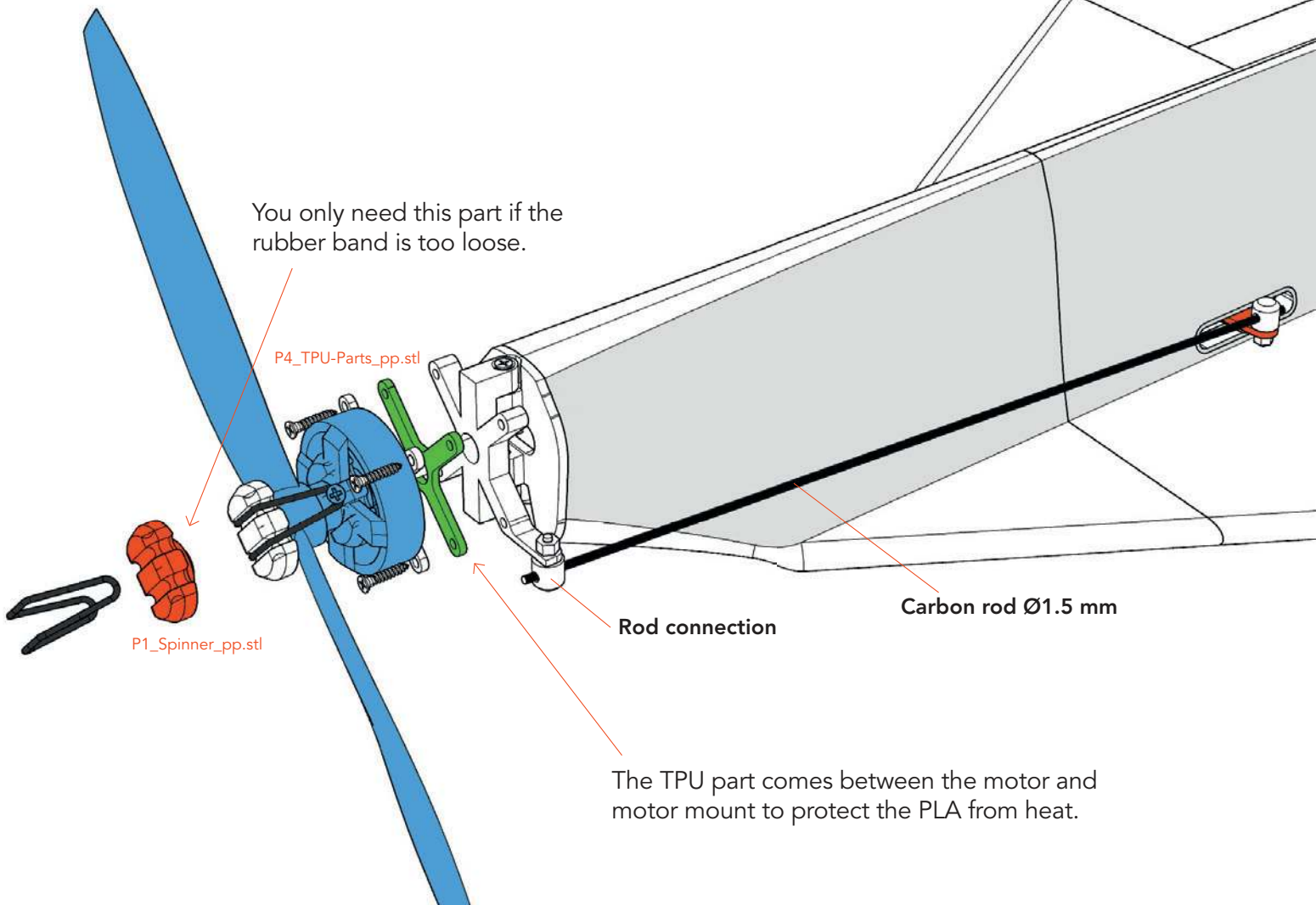
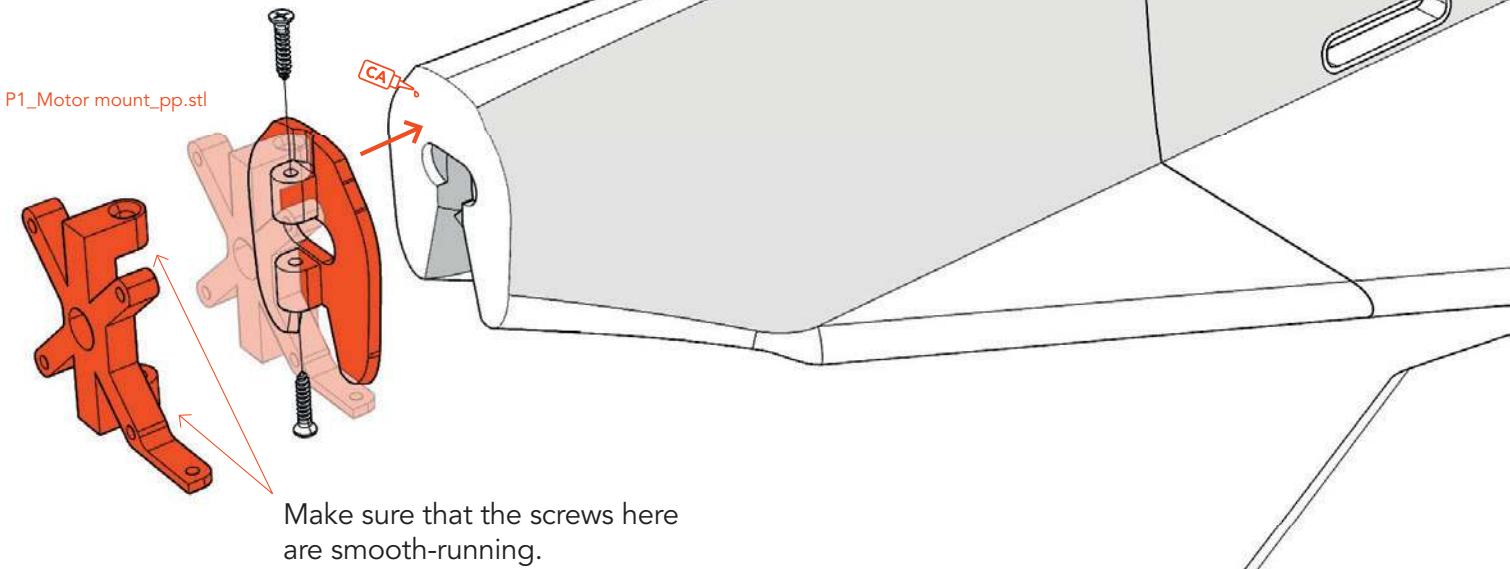

RC Components

Use self-adhesive Velcro tape to attach the battery.

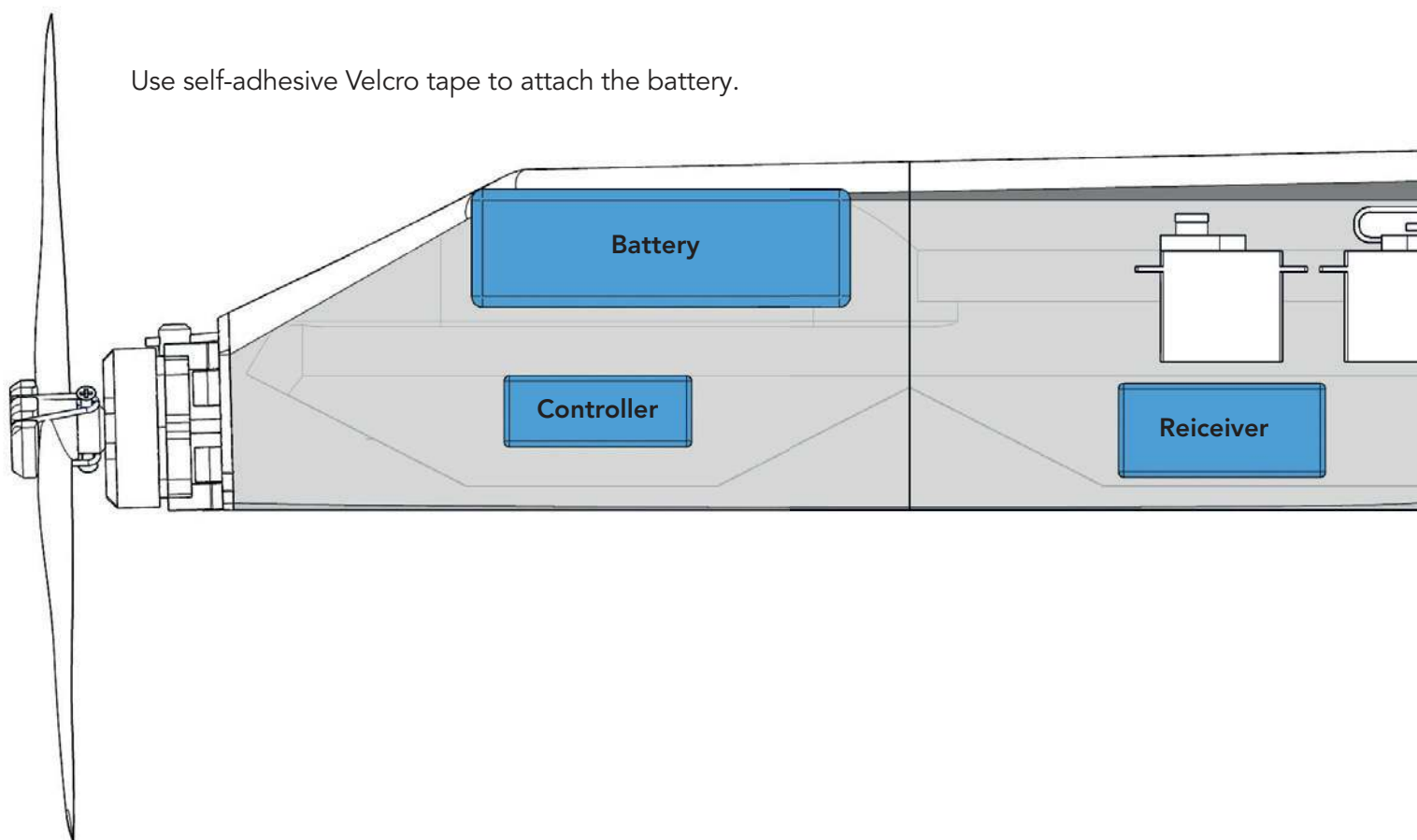

Storage

To avoid deformation, we recommend storing the model upside down on a filament box or similar.

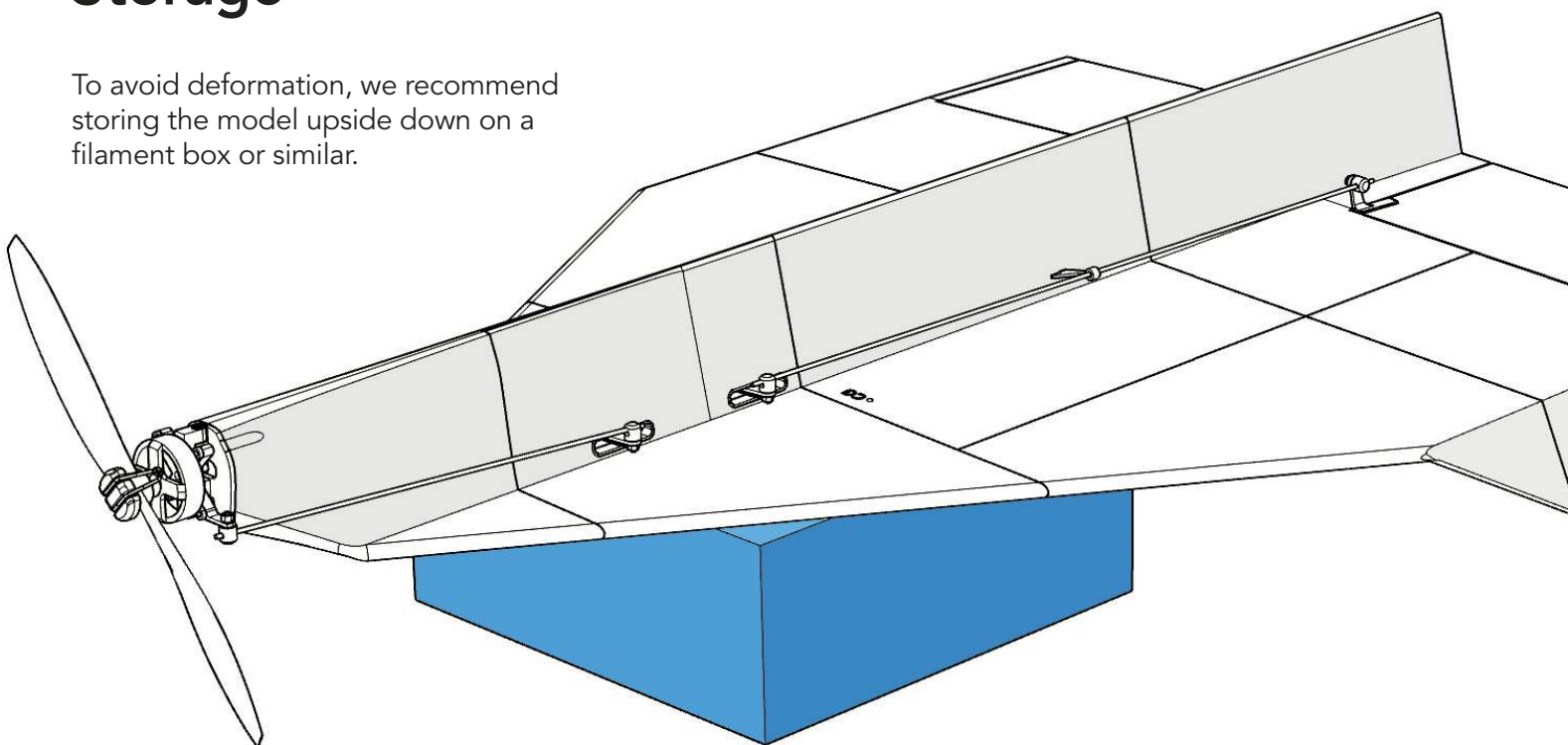

Technical specifications

WINGSPAN 500 mm/9.6 inches

LENGTH 700 mm/27.5 inches

FLIGHT WEIGHT 360 grams

WING LOAD 15 g/dm²

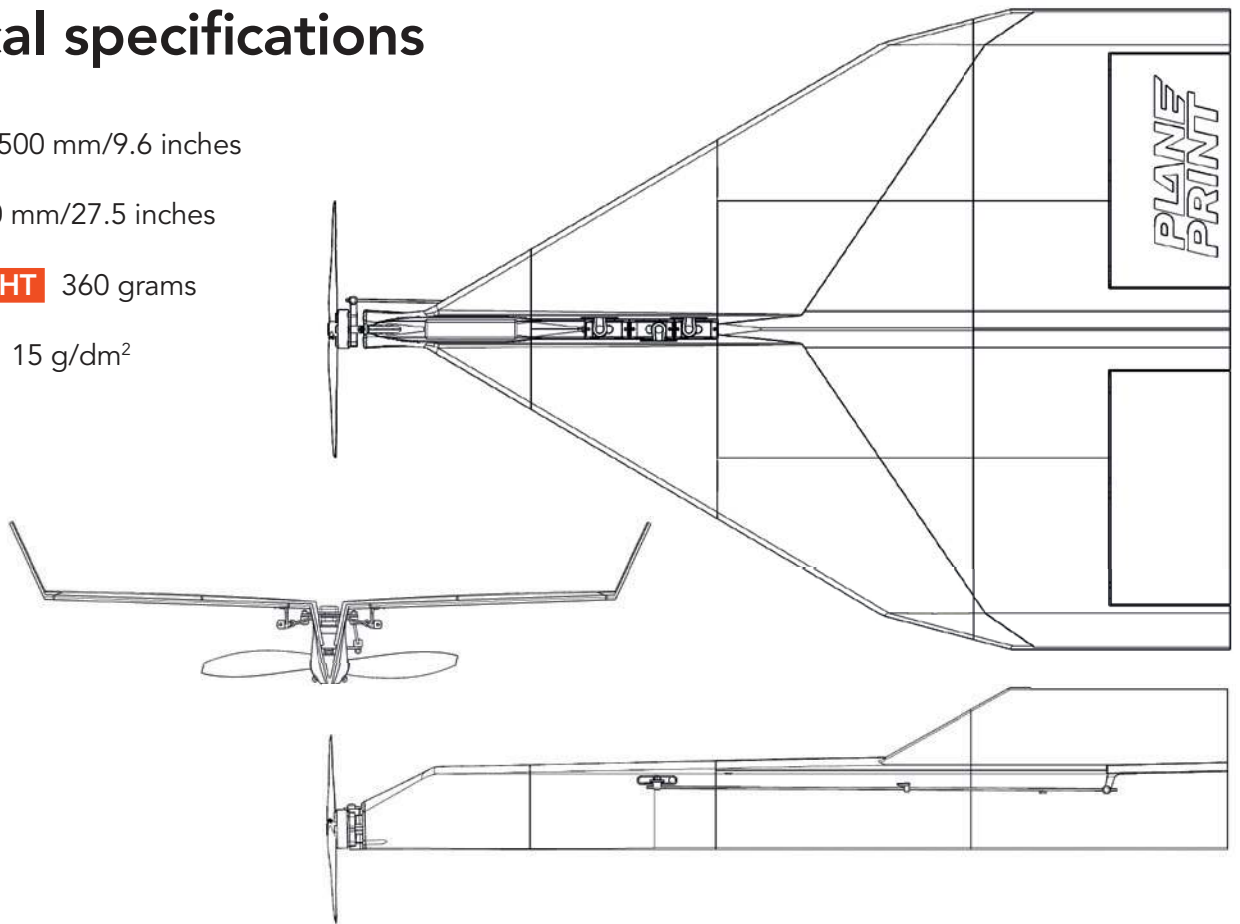

Center of Gravity (CG)

The aircraft must balance on these points – **see the markings on the fuselage.**

Do not forget to check if the wings are exactly in ballance in the roll axis. If one wing is heavier, correct this with a small weight on the wingtip.

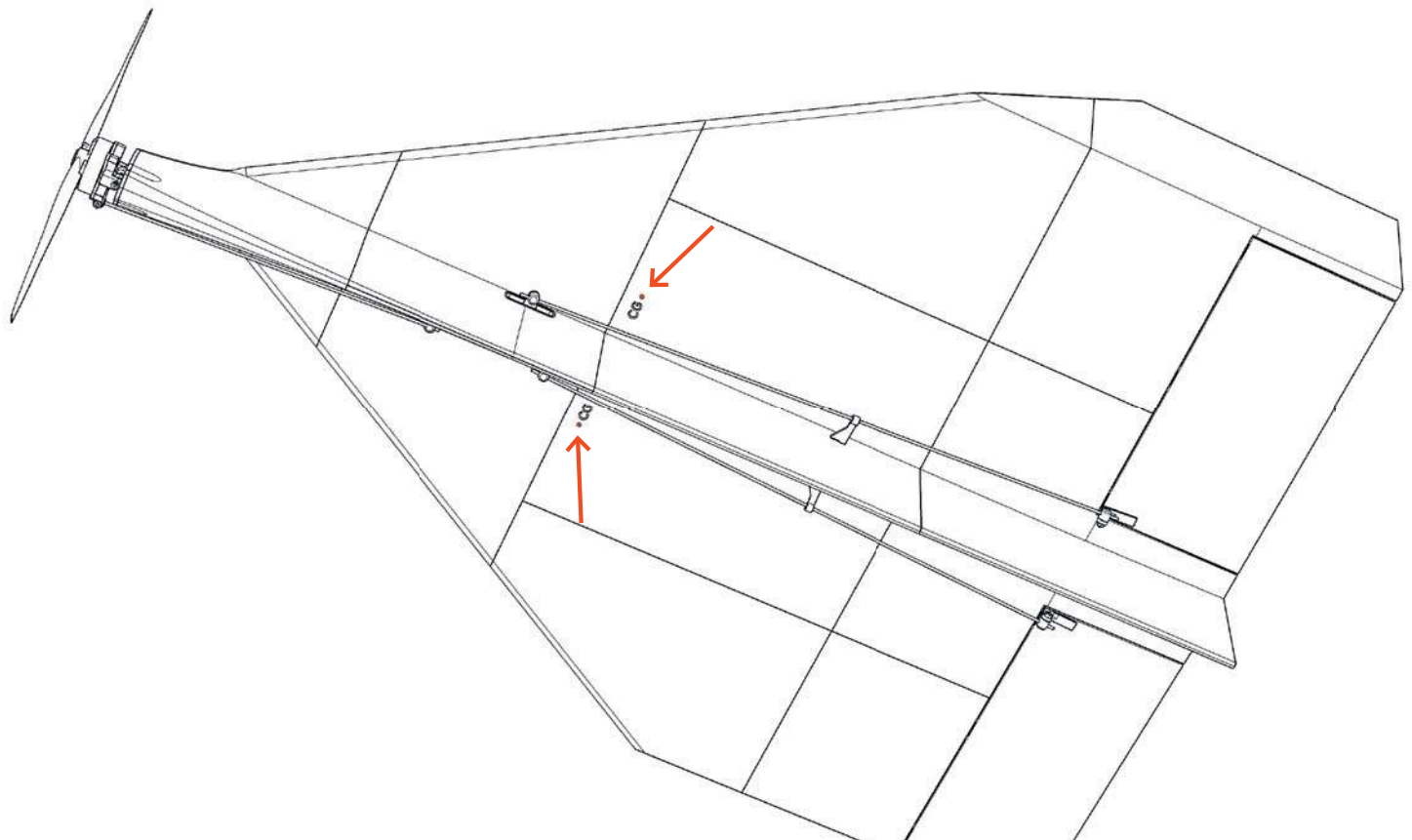

Control Direction Test

Turn on the transmitter and connect the battery. When checking the control directions, **look at the aircraft from above (rudder) and behind.** **Make sure that the motor does not start!** It is safer to dismount the prop.

RUDDER

Set the maximum possible angle.

Make sure that the prop in zero position points absolutely straight in flight direction.

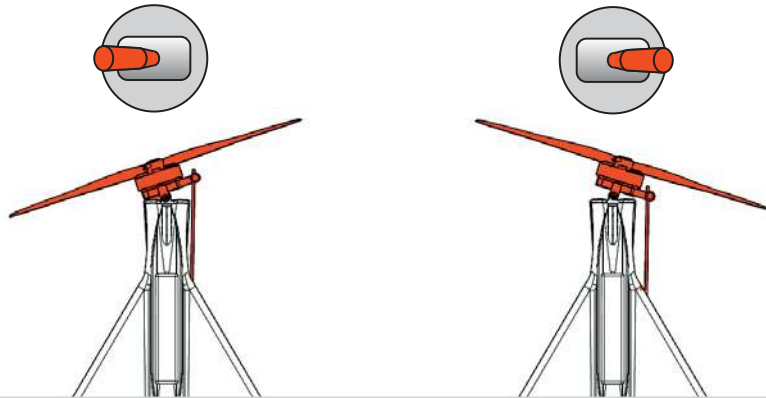

ELEVATOR

60 mm up
60 mm down

in zero position
the ailerons/
elevators
should point one
mm upwards.

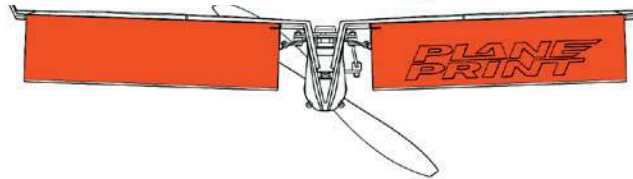
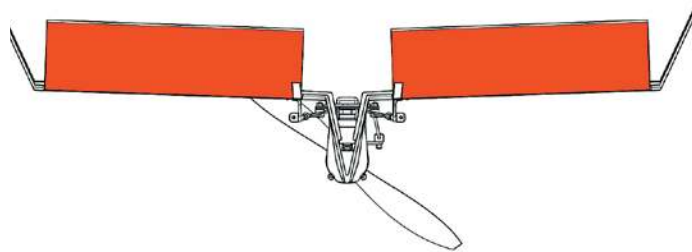

AILERON

60 mm up
60 mm down

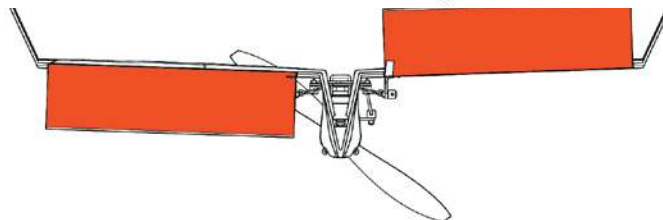
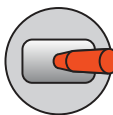
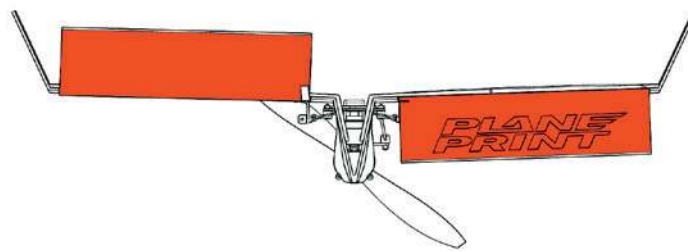
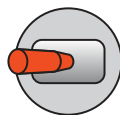

Tips for flying

Since the model flies very stable in the longitudinal axis, vector control (rudder) is absolutely necessary for flying curves. You should be able to control an airplane with the separate functions Rudder and Aileron, mixing these functions (Combi Switch) makes

no sense here. Always remember that vector control only works while the motor is running. The flight characteristics are very similar to a real paper airplane. It is very wobbly around the longitudinal axis, but flies stable overall.

AGE RECOMMENDATION 14+

NOT FOR CHILDREN UNDER 14 YEARS. THIS IS NOT A TOY!

The STL data (or data processed from it, such as G codes) must never be passed on to third parties!

The purchase of the STL does not authorize the production of models for third parties.

By using the download data, an RC model airplane, called „model“ for short, can be manufactured using a 3D printer. As a user of this model, only you are responsible for safe operation that does not endanger you or others, or that does not damage the model or property of others.

PLANEPRINT.com assumes no responsibility for damage to persons and property caused by pressure, transport or use of the product. Filaments, printing supplies, hardware or consumables that can not be used after faulty 3D printing will not be replaced by PLANEPRINT.com in any way.

When operating, always keep a safe distance from your model in all directions to avoid collisions and injuries.

This model is controlled by a radio signal. Radio signals can be disturbed from outside without being able to influence it. Interference can lead to a temporary loss of control.

Always operate your model on open terrains, far from cars, traffic and people.

Always follow the instructions and warnings for this product and any optional accessories (servos, receivers, motors, propellers, chargers, rechargeable batteries, etc.) carefully.

Keep all chemicals, small parts and electrical components out of the reach of children.

Avoid water contact with all components that are not specially designed and protected. Moisture damages the electronics.

Never take an item of the model or accessory in your mouth as this can lead to severe injuries or even death.

Never operate your model with low batteries in the transmitter or model.

Always keep the model in view and under control. Use only fully charged batteries.

Always keep the transmitter switched on when the model is switched on.

Always remove the battery before disassembling the model.

Keep moving parts clean and dry at all times.

Always allow the parts to cool before touching them.

Always remove the battery after use.

Make sure that the Failsafe is properly set before the flight.

Never operate the model with damaged wiring.

Never touch moving parts.

We develop our models to the best of our knowledge and belief. We accept no liability for consequential damage and injuries caused by improper use or incorrectly printed parts. **Please be careful when handling motors, batteries and propellers** and only move your model with insurance and in approved places!

PLANE PRINT