

TA HORIZONS

PRO EXTRA

ULTRALIGHT SERIES V2



TA HORIZONS 34" PRO EXTRA V2 ULTRALIGHT ASSEMBLY INSTRUCTION MANUAL

Technical Data-

Wingspan : 34"

Length : 35"

AUW : 160-190g

(Depends upon the setup used)

Setup Recommendations (Not Included)-

Motor : 18-22G 1800-2300KV Outrunner

ESC : 12-16 amp

Servos : 3 X 9gms each

Propeller : 8-9" electric

Battery : 450-600Mah 2-3S Lipo

EPP CONSTRUCTION

MOTOR
HOBBY

KIT ONLY

WWW.TAHORIZONS.COM



WARNING INFORMATION & SAFETY INSTRUCTIONS

Website: www.tahorizons.com

Email: tahorizons@gmail.com

Thank you for choosing TA Horizons. **Please read the entire manual thoroughly before you begin to assemble this model.** If you have any questions, please contact us aforementioned email address.

This R/C airplane is not a toy! Read and understand the entire manual before assembly. If misused, it can cause serious damages to life and property. Fly only in open areas. If you are not an experienced pilot and airplane modeler you must take the help of an experienced pilot or an authorized flight instructor for the building and flying of this model aircraft.

These instructions are suggestions only on how to assemble this model. There are other ways & methods also to do so. TA Horizons has no control over the final assembly because it specifically depends upon the knowledge and experience of the person involved directly in its handling, or the manner in which the model is assembled, radio gear installed, and electronic parts are used and maintained. Thus, no liability is assumed or accepted for any damages resulting from the use of the assembled model aircraft. By the act of using this user-assembled product, the user accepts all the resulting liabilities. In no event shall TA Horizons' liability exceed the original purchase price of the kit.

The user is advised to comply with all local laws and regulations. TA Horizons will have no responsibility over the user assembled product and its end use. TA Horizons has the right to change any content on the website, product information brochure, or the manuals, at any point of time without any prior notice.

TA Horizons checks each plane before shipping to ensure that each kit is in fine condition. We have no bearing on the condition of any component parts damaged by use, modification, or in assembling of the model. Inspect the components of this kit upon receipt. If you find any parts damaged or missing, please contact TA Horizons immediately. We will not accept the return or replacement of parts on which assembly work has already begun.

Our goal is to bring to you the best in quality and state of the art radio controlled aircrafts. For those who demand the ultimate in precision, or for those who are just a weekend flyers and want to feel good about their flights, our planes are in development from many months and tested to ensure that these aircrafts will give you the best possible performance. We sincerely hope that our products can provide the same thrill to you that we experience in this hobby.

Kit Contents

1. EPP Parts



EPP Parts

- ① Fuselage
- ② Wings
- ③ Horizontal stabilizer
- ④ Horizontal profile section
- ⑤ Wing truss supports X 2
- ⑥ Landing gear cover X 2
- ⑦ Side Force Generators X 5
- ⑧ Wheel Pants X 2
- ⑨ Aileron truss support X 2

2. Hardware / Small Parts

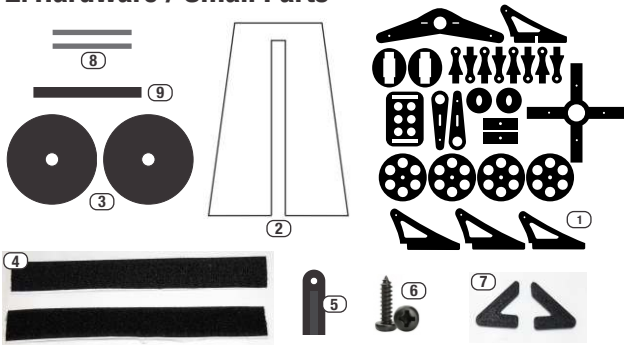

Hardware Parts

- ① 3D printed kit parts
- ② Fuselage assembly jig
- ③ EPP Wheels X 2
- ④ 150mm velcro
- ⑤ Quick links (4 X 1.5mm Slot, 4 X 1.2mm Slot)
- ⑥ Selftaping screw X 12
- ⑦ 3D printed wheel bracket X 2
- ⑧ 40mm 2mm CF Wheel Shaft X 2
- ⑨ 60mm CF strip

3. Carbon Rods / Strips / Tubes



Carbon Rods / Strips / Tubes

- ① Flat 3X1mm 660mm L Front wing spar
Flat 3X1mm 325mm L Elevator spar
Flat 3X0.5mm 190mm L Ailerons renf X 2
Flat 3X0.5mm 180mm L Fuse renf
Flat 3X0.5mm 130mm L Fuse renf
- ② Control rods
D 1.2mm 450mm L X 2 (Ele & Rud)
D 1.5mm 100mm L X 2 (Ailerons)
- ③ Undercarriage sq.tube
D 2x3mm L 225mm X 2
- ④ 1mm Reinforcement Rods
L 1000mm X 10

Please Note: After removing kit from shipping box, lay each piece flat on a hard surface, this will allow the airframe to straighten out if lightly bent from shipping. Do not worry since EPP is very pliable and can be bent back if out of shape. Double check that you have all the above pictured items. If any of the airframe or hardware items are missing, contact TA Horizons before starting your build.

Exploded View

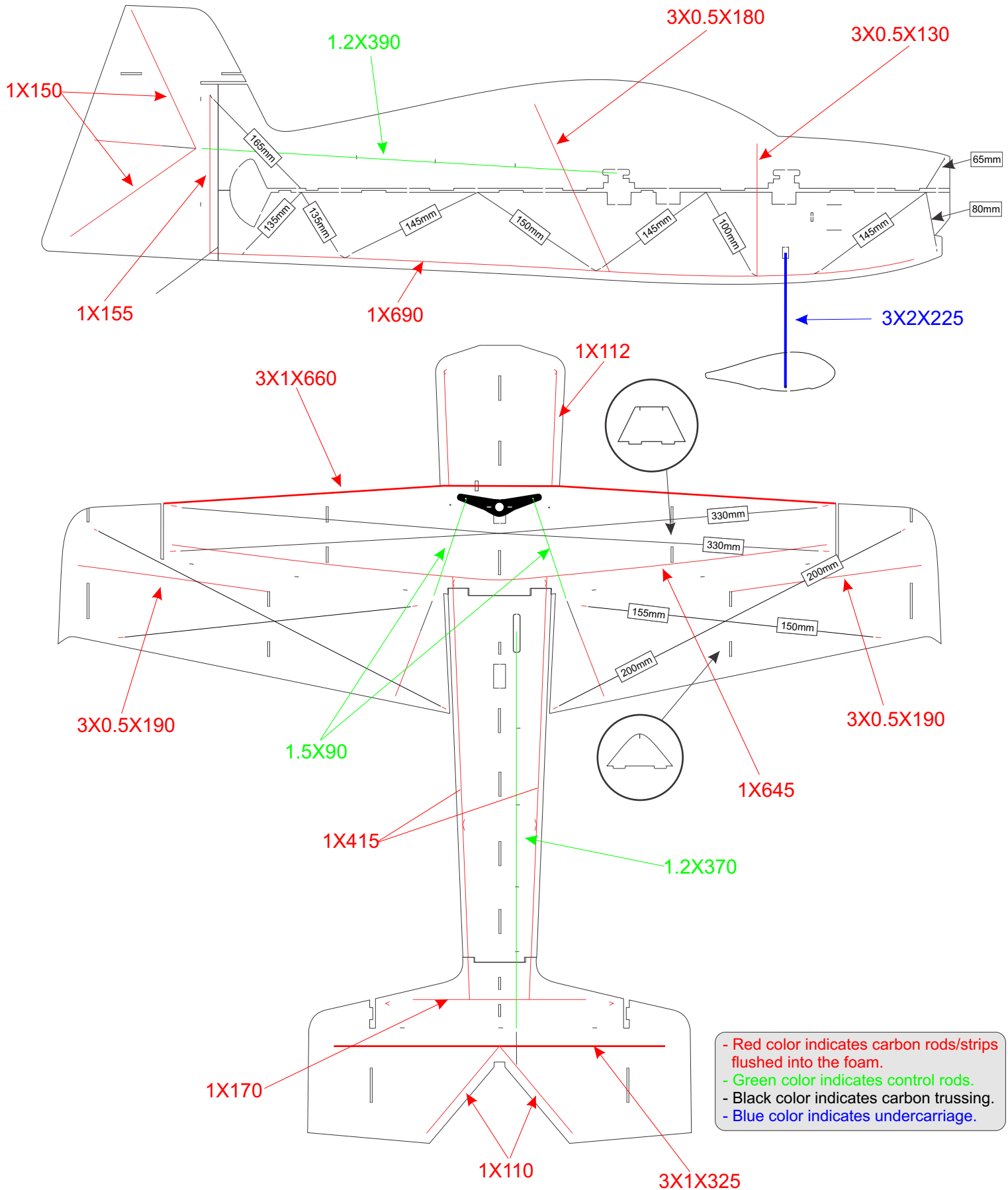

TOOLS AND BUILDING MATERIAL REQUIRED

- Heat Gun
 - Tape Measure and Ruler
 - Black Sewing Thread
 - High Viscosity CA
 - CA Spray Activator
 - Hobby Knife w/new Blade
 - Needle Nose Pliers
 - Wire Cutters
 - Low Temp Hot Glue Gun
 - Scissors
 - Small Phillips Screw Driver
 - Thin CA
 - Alenkey
-



The Build

Please Note: Few pictures shown below are of different plane and for reference purpose only.



1. (This is mandatory step) locate the hinged items as shown above, Bend them back on to each other as shown and let set for at least 2 hours. This will help to loosen up the movement of the surface.



2. Make a neat line of hot glue over any old credit card and spread it over the hinge line show in the next picture.

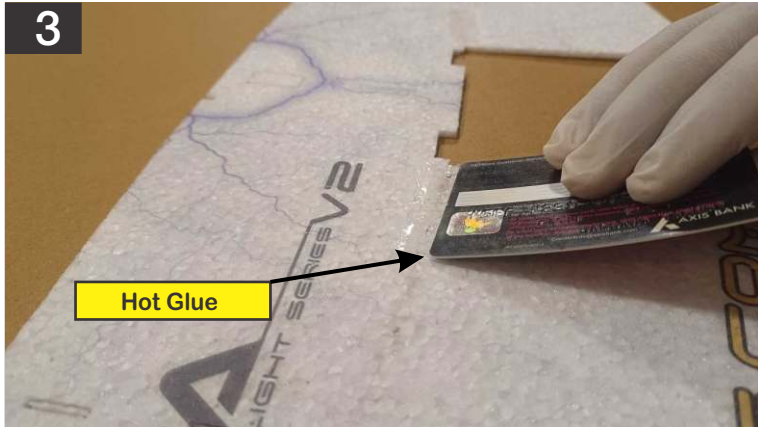

3. It is very important to put glue on card first and then spreading a thin layer over the hinge line otherwise if put directly over foam you might end up melting EPP.



4. It is not required to put glue all the way to hinge line just a inch of glue on both inboard and outboard of the surface will do the job.



5. Here is the right amount of hot glue spread over the hinge line.

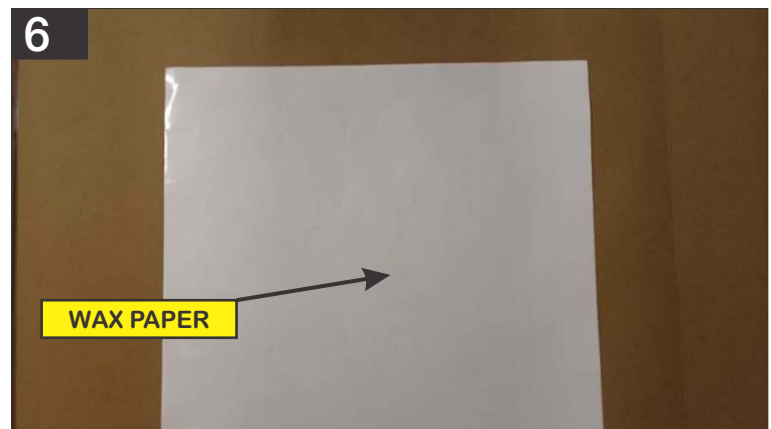

6. Building surface should be at least 2ft x 4ft and flat, use a wax paper over the surface to avoid sticking EPP on it when gluing.

The Build

Please Note: Few pictures shown below are of different plane and for reference purpose only.



7. Locate the 3mm X 660mm CF Spar shown in the picture above



8. Apply a thin layer of HV Cyno on CF Spar, and glue it on the leading edge of wing, like shown above.

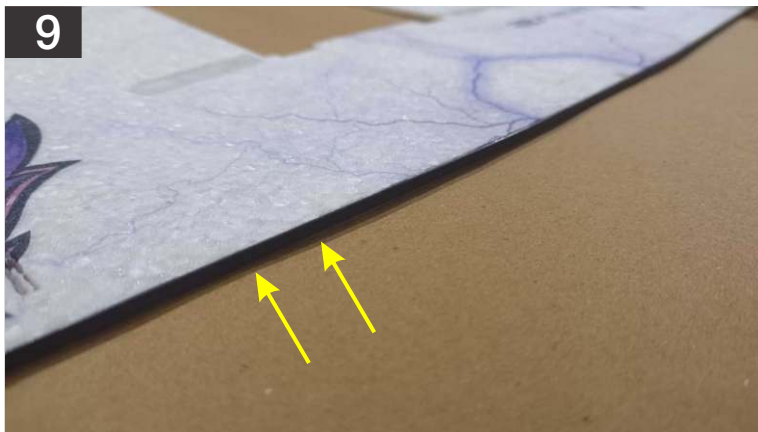

9. Make sure to lay down the wing on the flat surface while glueing the CF stripe.

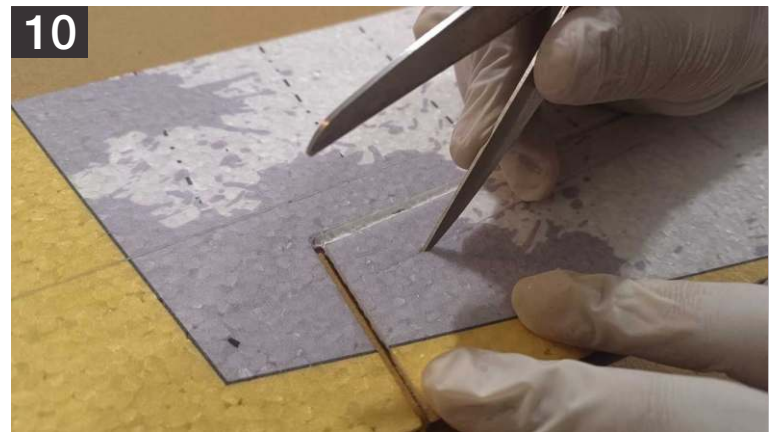

10. Turn back the wing to glue down the reinforcement rods, if needed use a scissor or a ball point pen to loosen down the pre cut laser lines.

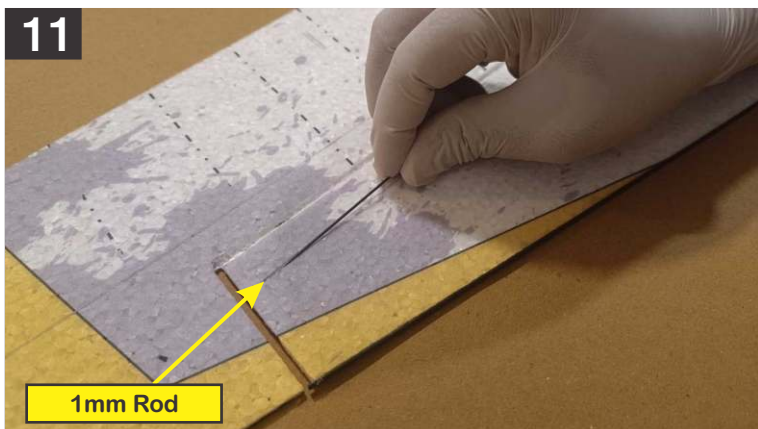

11. For rear wing re-inforcement, insert the supplied 1mm rod into the pre cut slot. (Check the page 4 of exploded view for more clear idea)



12. Make sure it is completely inserted into the slot.

The Build

Please Note: Few pictures shown below are of different plane and for reference purpose only.

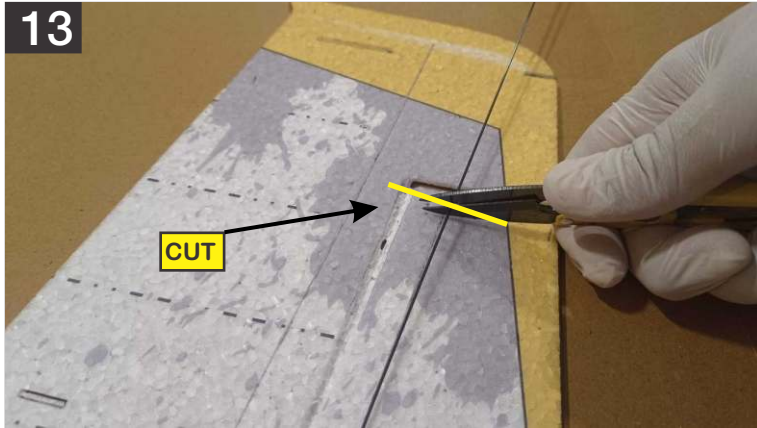

13. Once it reached at the end of Pre-cut slot, use a scissor or wire cutter to cut down the excess rod.



14. Use thin cyno to glue this rod (Do not use HV CA), use spray activator to cure it.

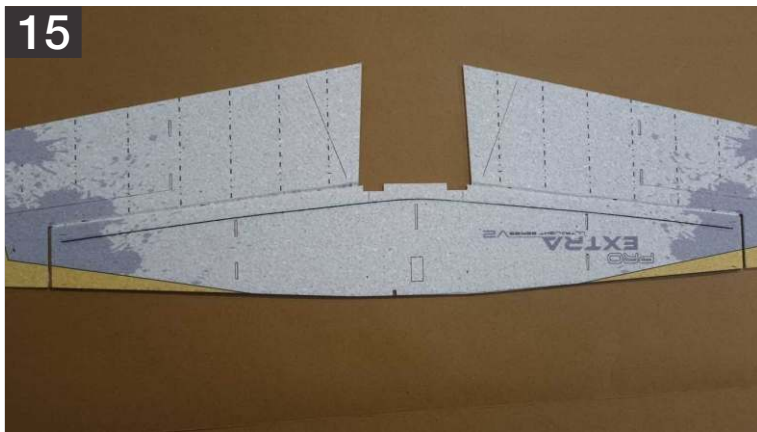

15. Here are both Leading edge stripe (3X1mm) and rear wing reinforcement 1mm rod glued to the wing.

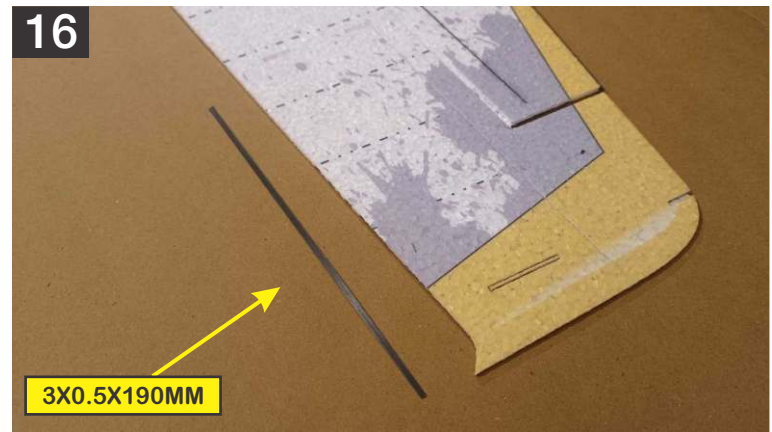

16. Locate the 3X0.5mm 190mm L CF Stripe for aileron reinforcement.

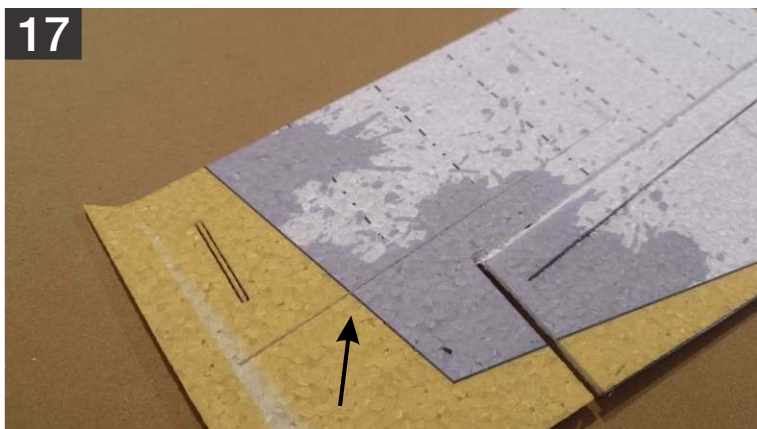

17. Laser grooving for aileron reinforcement stripe is also pre cut.

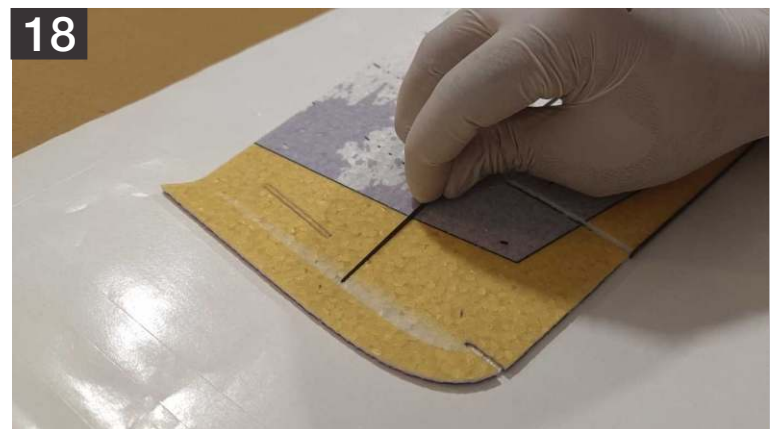

18. Insert the stripe vertically into the precut slot, make sure it is completely inserted into the slot.

The Build

Please Note: Few pictures shown below are of different plane and for reference purpose only.

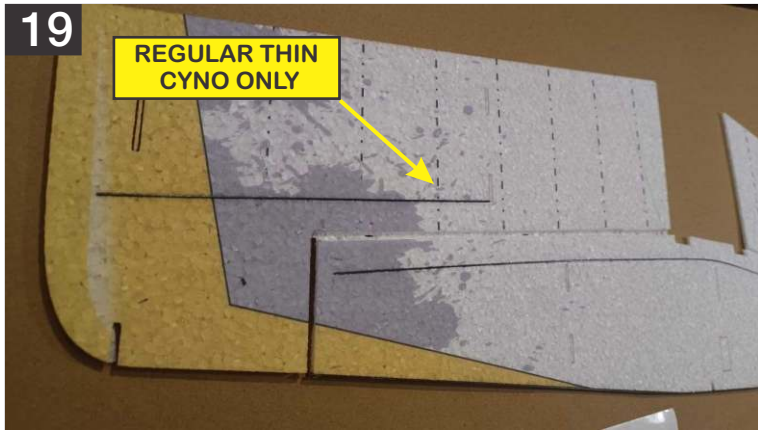

19. Use thin cyno to glue this stripe (Do not use HV CA), use spray activator to cure it.

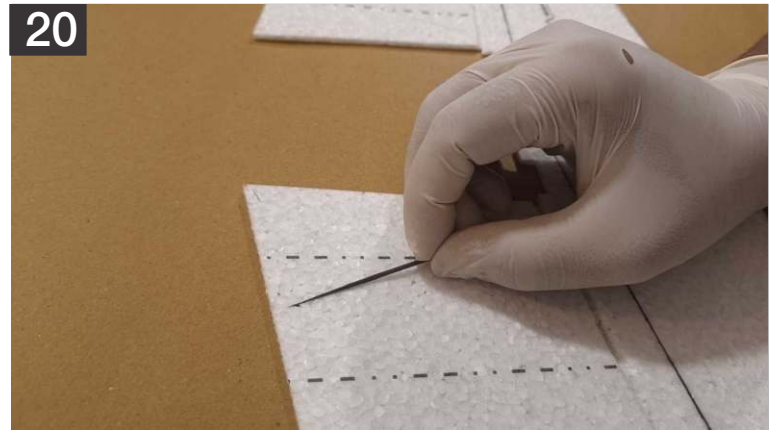

20. Up next is gluing the 1mm carbon rod into the precut slot for aileron horn reinforcement.

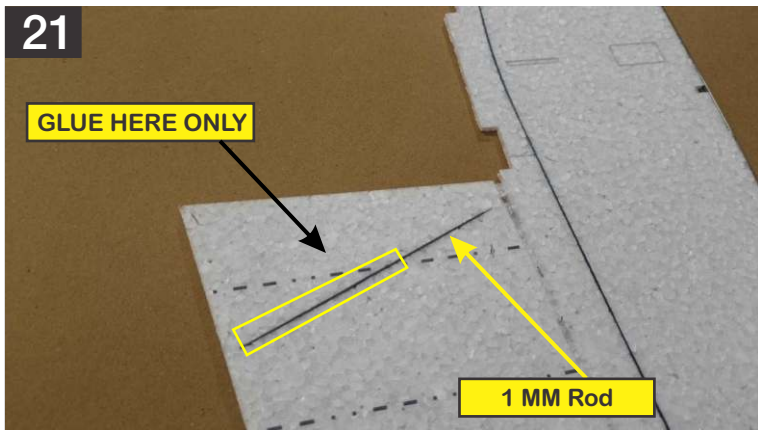

21. For now, Only glue the indicated part of the rod, we will later glue the complete rod along with the control horns.

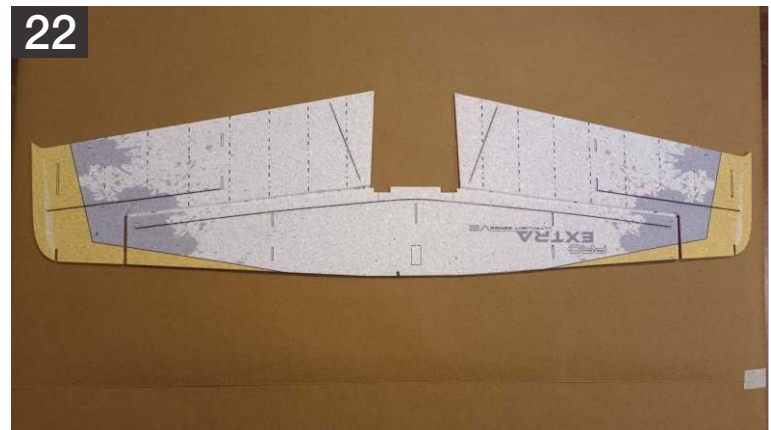

22. Here is the complete wing reinforced using the carbon stripes and rods. Make sure everything is flushed inside and perfectly glued.

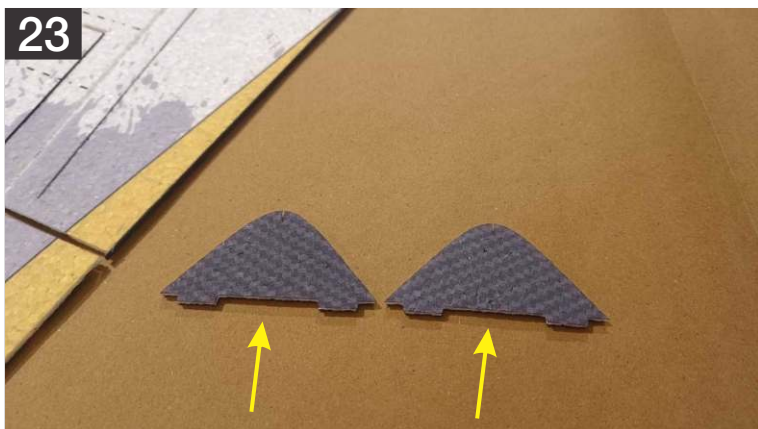

23. locate these triangle shaped pieces of foam for aileron trussing.

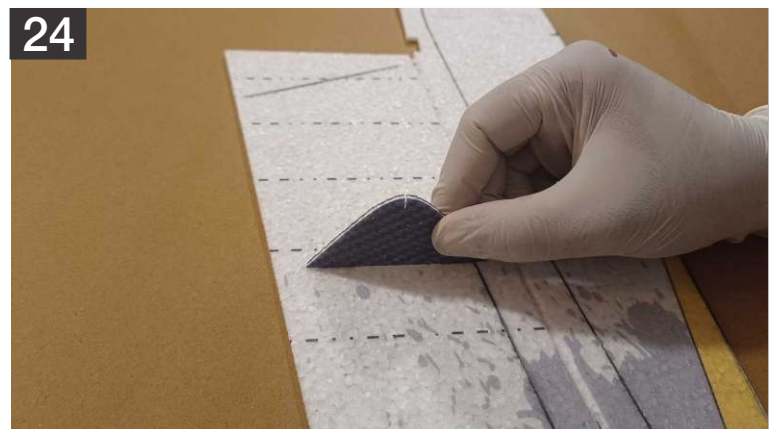

24. Using the HV Cyno and kicker, install the center support into it's respective slots located in the aileron control surface.

The Build

Please Note: Few pictures shown below are of different plane and for reference purpose only.

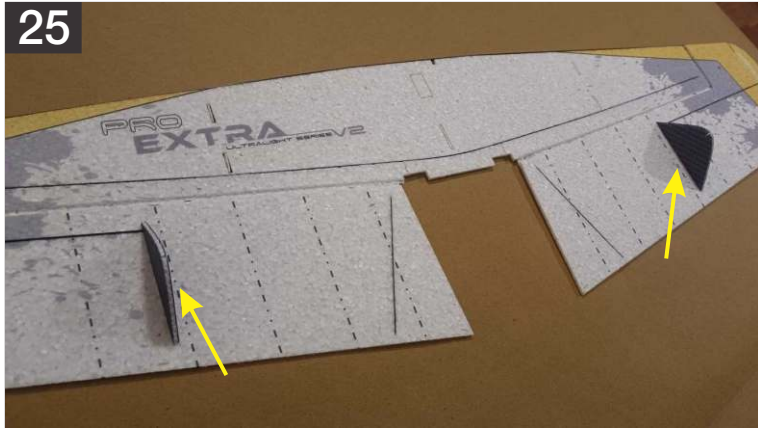

25. Once installed into the slots, make sure it is square, repeat for the other side.

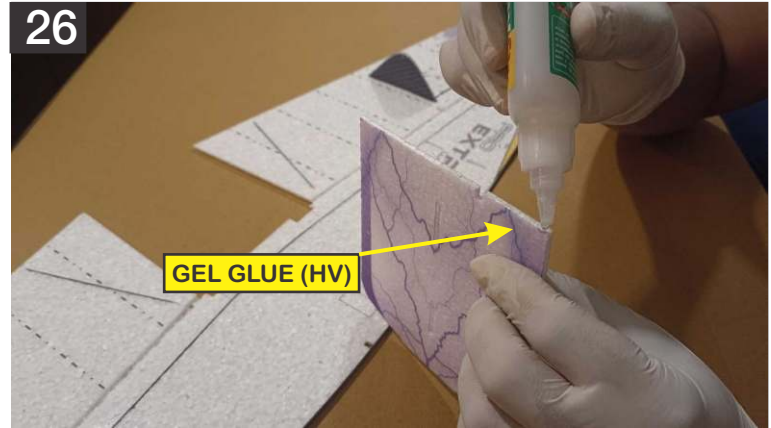

26. Horizontal fuselage nose section is next, Apply a bead of HV CA to the edge of the nose piece that contacts the leading edge of the wing as shown above.

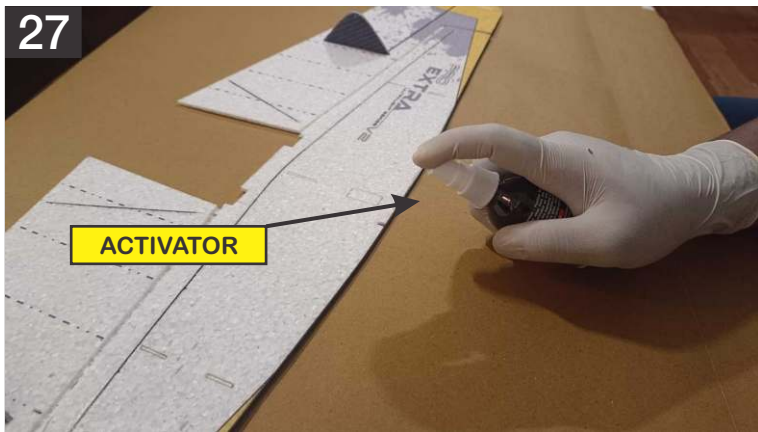

27. Spray Activator (Kicker) to the mating surface of the wing's leading edge.

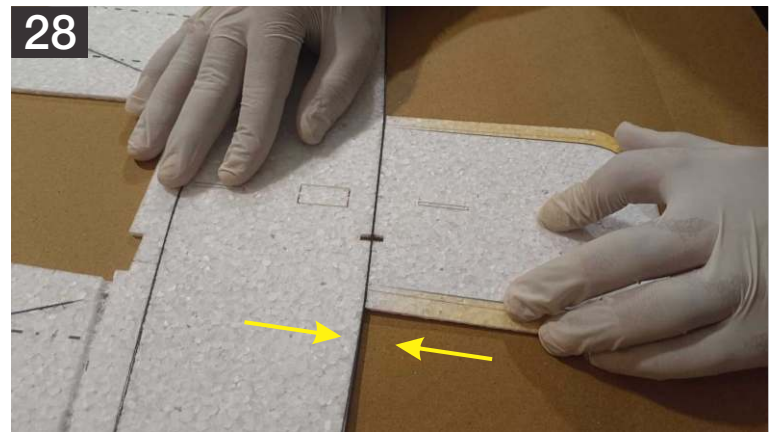

28. Using a straight edge and the indicated cutout as a guide for alignment, bring the two pieces together. Make sure also that both pieces are at on the workbench.

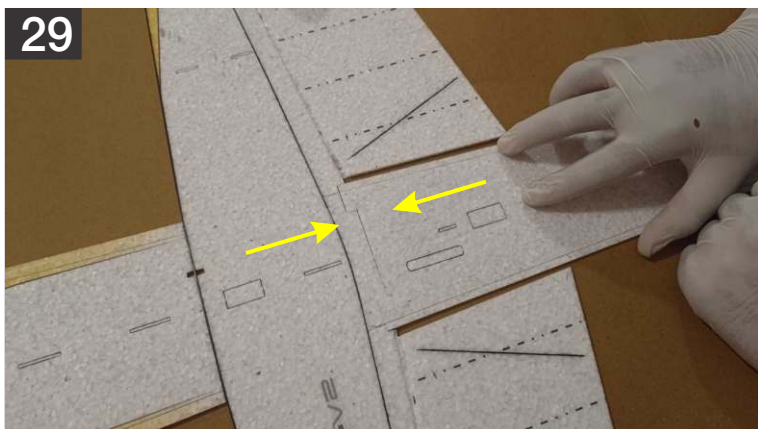

29. Lay down the shown parts on the flat surface with wax paper on it and glue it together. Note that we are working from the bottom side. The bottom side of this part is the side WITHOUT any printing.-

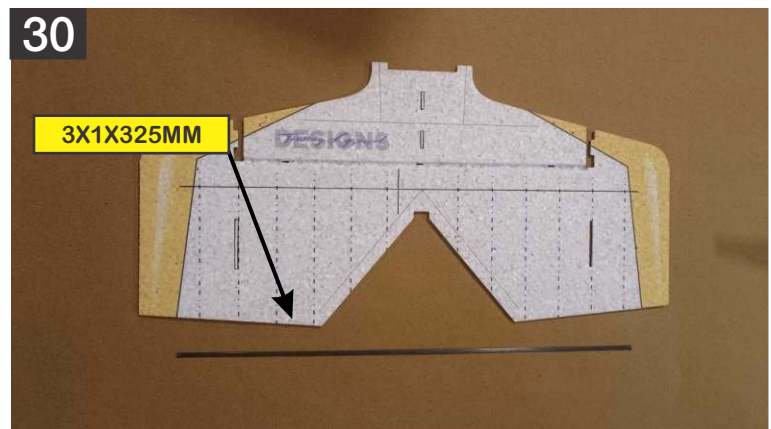

30. Locate the 1X3mm 325mm L stripe for elevator reinforcement.

The Build

Please Note: Few pictures shown below are of different plane and for reference purpose only.

31

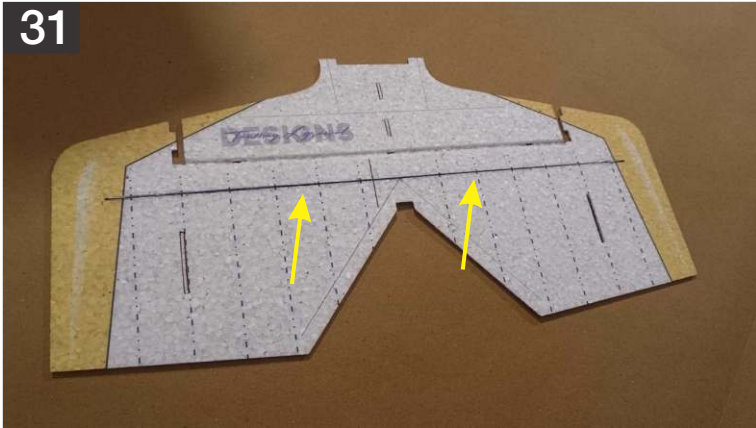

31. Glue it in the pre-cut groove, Use a spray activator (Kicker) to cure, wipe off the excess glue if needed.

32

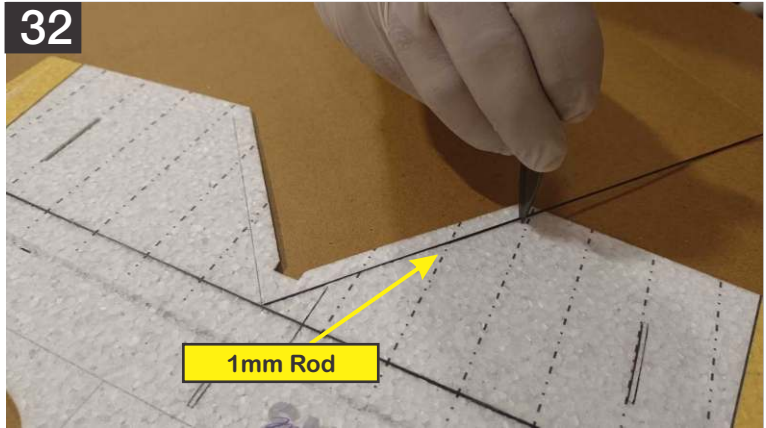

32. Install the 1mm carbon rod as shown above, again you need to cut the required length from the supplied 1000mm rod or from any excess remaining rod from the previous steps.

33

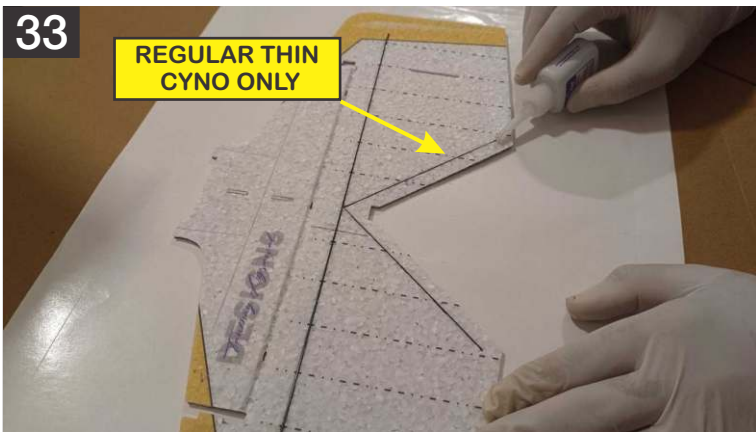

33. Apply a thin CA, don't forget to use a nonstick paper or something similar.

34

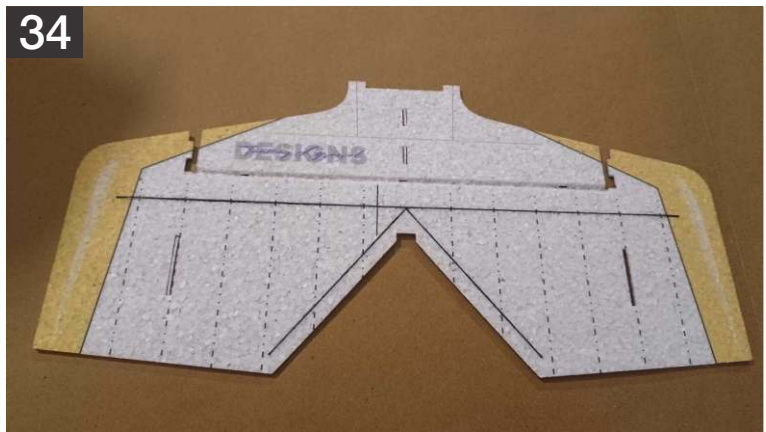

34. Make sure they are flush. Spray the area with the kicker.

35

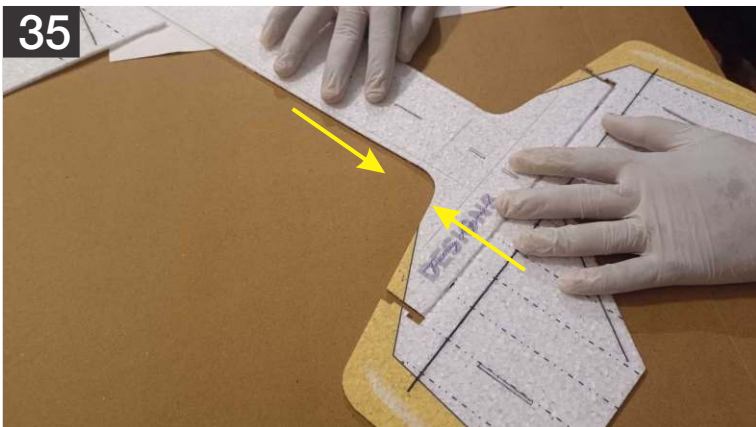

35. Lay down the shown parts on the flat surface with wax paper on it and glue it together.

36



36. Reinforcement of horizontal profile section is next, make sure that the slot in the area where the elevator attaches is free of glue.

The Build

Please Note: Few pictures shown below are of different plane and for reference purpose only.



37. Repeat the process where it attach to the wing as well.



38. Install the 1mm carbon rod to reinforce the tail section as shown above.



39. Again you need to cut the required length from the supplied 1000mm rod or from any excess remaining rod from the previous steps.

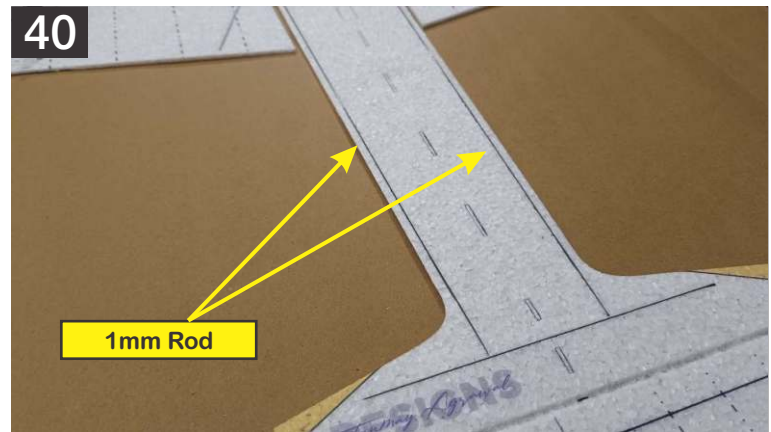

40. The horizontal piece of the fuselage also uses the 1mm carbon fiber rod spanning the entire length from the rear wing spar to the horizontal stab spar, cut the required length and insert the rod into the precut slot like shown above.



41. Make sure everything is flushed, Use a thin CA to glue it.



42. Hit with kicker and verify that there is a good solid bond, if there are loose areas simply add a little more CA and Kicker.

The Build

Please Note: Few pictures shown below are of different plane and for reference purpose only.

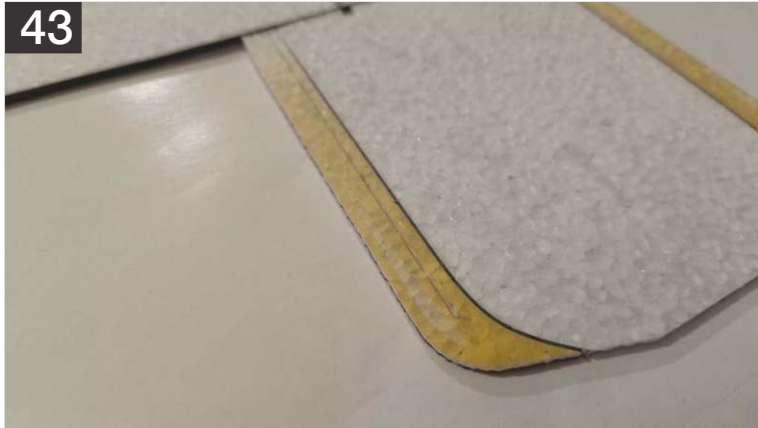

43. Horizontal fuselage nose section also uses the same 1mm carbon rod for reinforcement, locate the pre cut grooves as shown above.

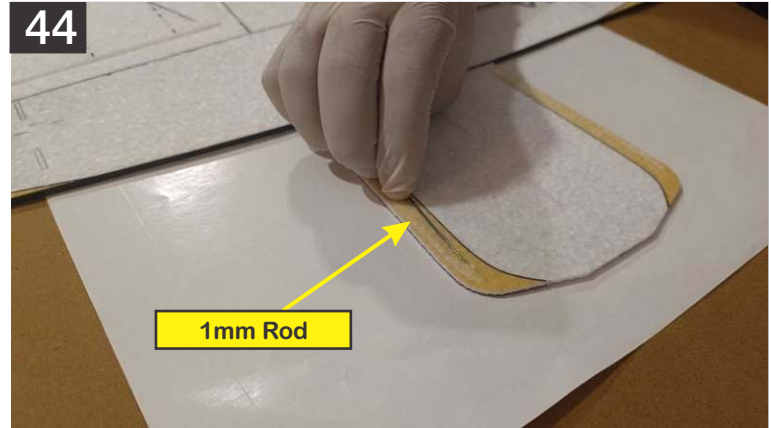

44. Install the 1mm carbon rod as shown above, again you need to cut the required length from the supplied 1000mm rod or from any excess remaining rod from the previous steps.



45. Use a thin CA and kicker to glue it.

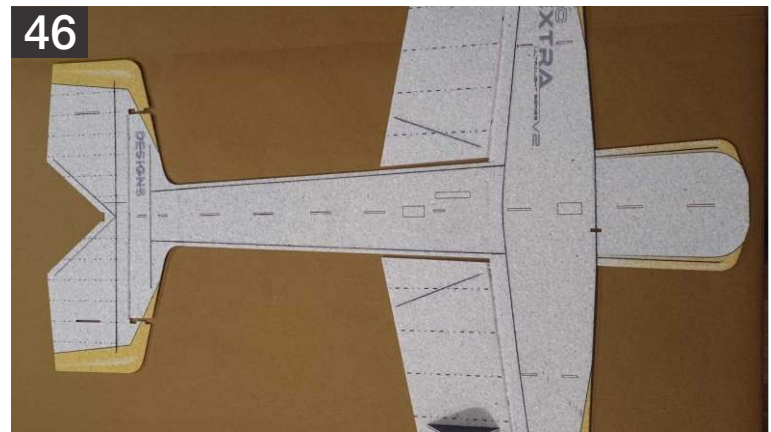

46. Here is the complete bottom view of horizontal airplane section reinforced with carbon rods and stripes.

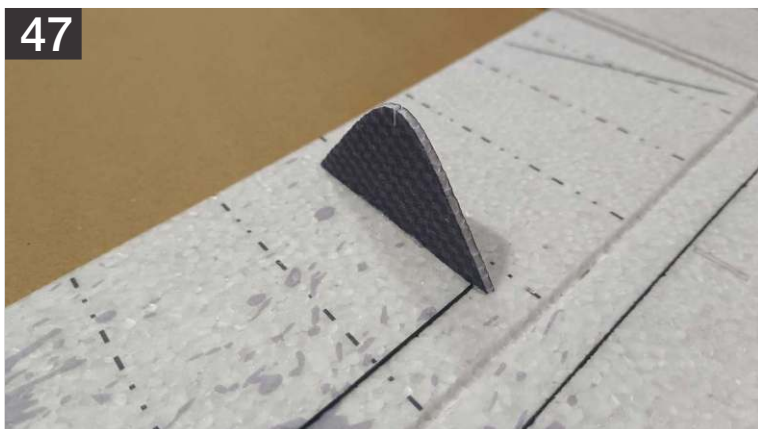

47. Aileron Trussing is up next. Make sure the triangle piece of foam that we have glued previously remains square throughout the next steps.

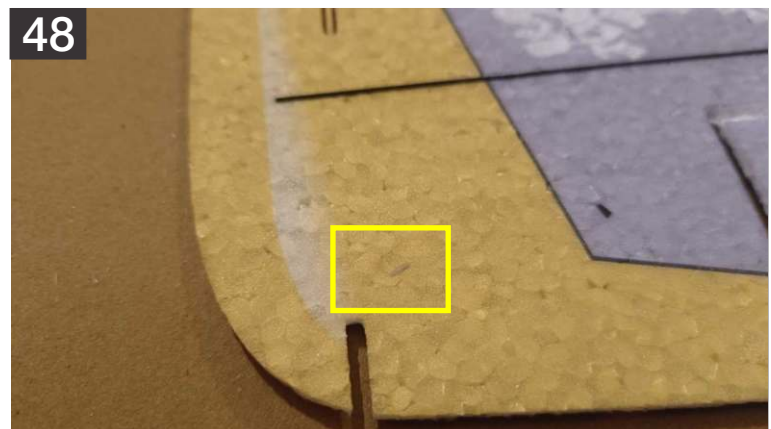

48. Locate the pre cut small slits on all 4 sides of aileron to insert the rods into.

The Build

Please Note: Few pictures shown below are of different plane and for reference purpose only.

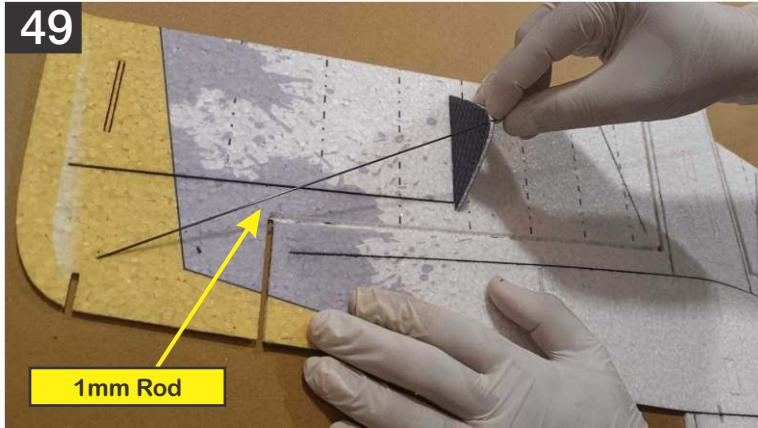

49. Locate one end of the 1mm carbon rod into the outboard slit, near the leading edge of the aileron. Next make note of where the rod crosses the center support, as indicated above, and cut the rod.



50. Once the rod is split, locate the opposite end of the rod, insert it into a pre cut slit like shown above.



51. Once happy with the location and flatness of everything, glue the ends and center area with CA.

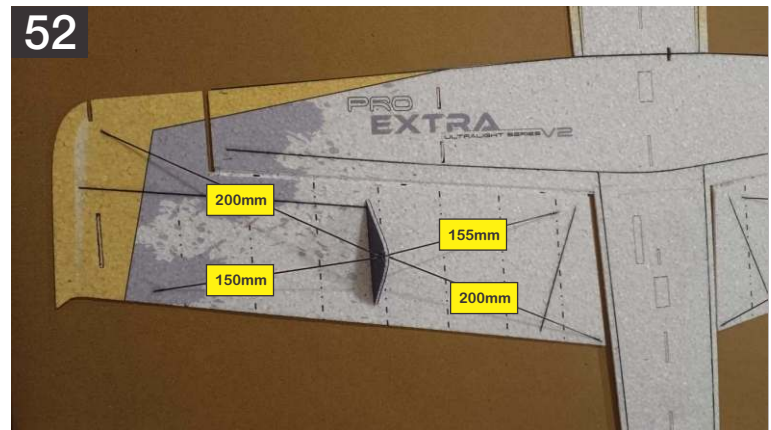

52. All truss rods shown in position. Make sure the aileron is at on the work surface and that the center support is still square.



53. Repeat for the other side.



54. Up next is the vertical fuselage section.

The Build

Please Note: Few pictures shown below are of different plane and for reference purpose only.

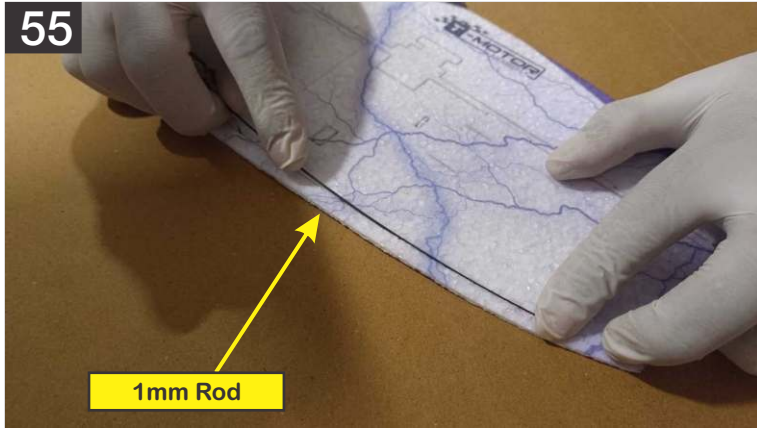

55. Belly of vertical fuselage also uses the 1mm carbon rod for reinforcement, Lay into it's designated slot. Again use the 1000mm 1mm carbon rod, cut length as advised in the next step.

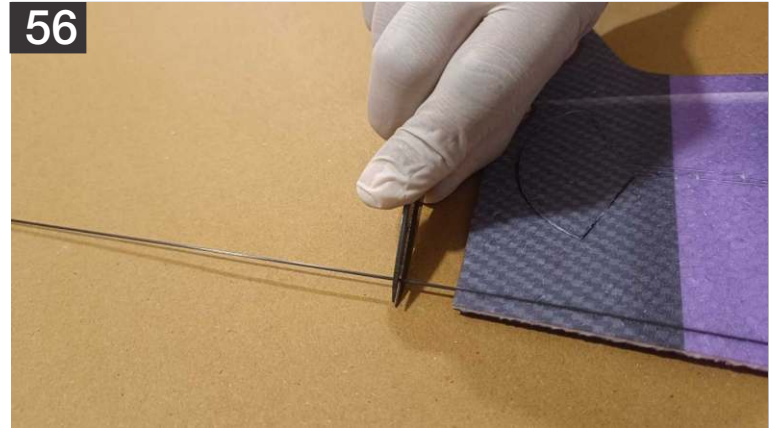

56. NOTE - this will stick out approx 1/2inch beyond the end of the tail of this piece shown in the above picture.



57. We can now began the vertical fuselage installation, use the blade to separate both the parts



58. We can now began the vertical fuselage installation, use the blade to separate both the parts

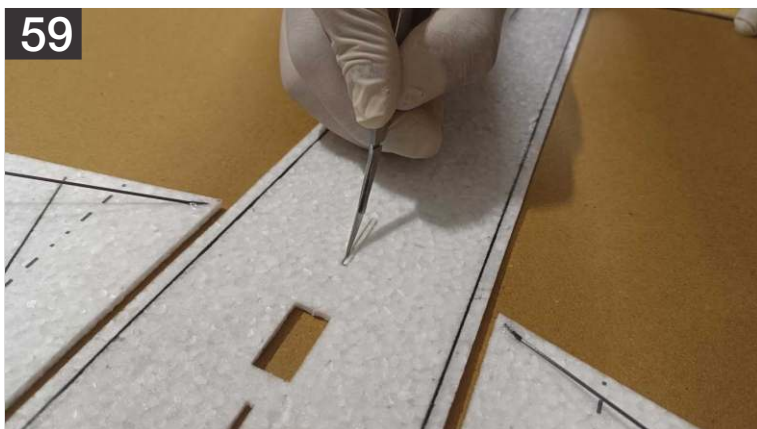

59. Use a blade to take out all the foam out of the assembly slots.



60. Apply a thin layer of HV CA to the mating surfaces of the lower vertical fuselage.

The Build

Please Note: Few pictures shown below are of different plane and for reference purpose only.

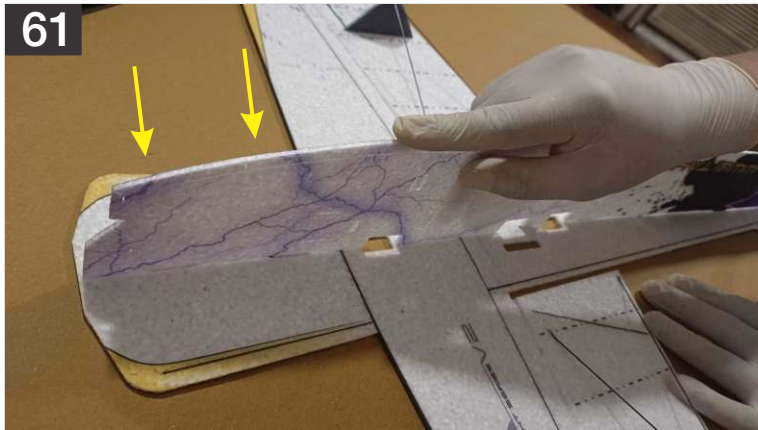

61. Bring the two pieces together. Make sure the tabs and slots of the two pieces are fully engaged, flush and square.

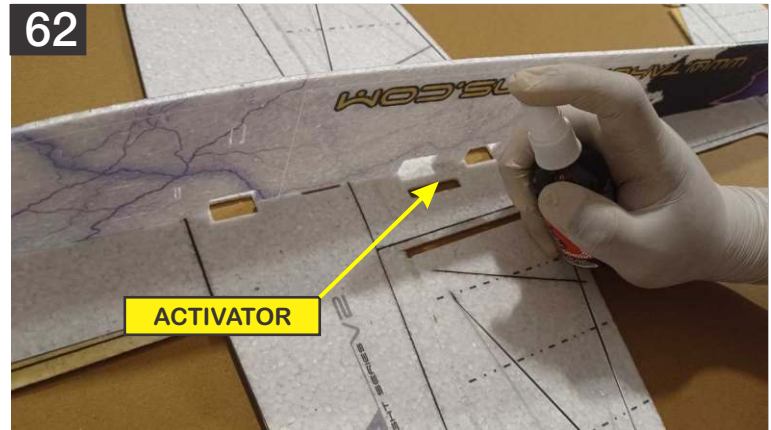

62. You will have a little time to work with and adjust for squareness. Use a spray activator to cure it.

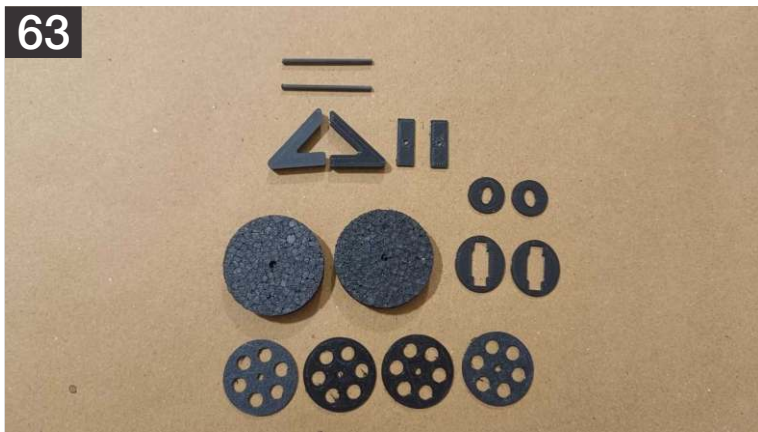

63. Locate the above parts for the undercarriage assembly.



64. Glue the center rim over the supplied black EPP wheels with center hole aligned using HV CA (Do it for both the sides of wheels).

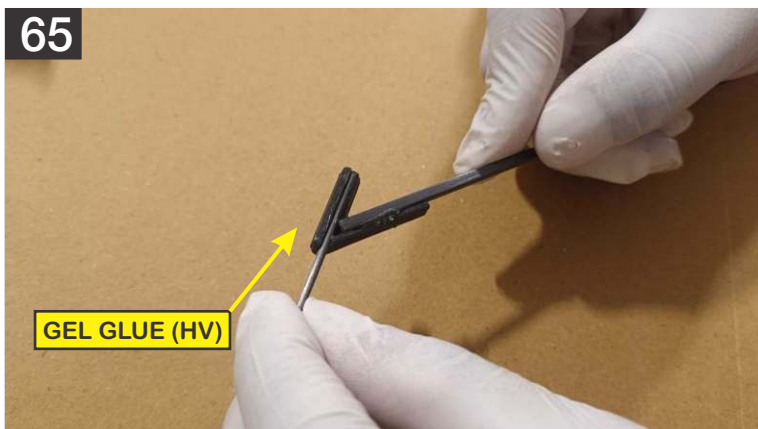

65. Here the supplied (3mm dia 225mm) tube and (2mm dia 40mm) wheel shaft are glued on the wheel bracket.



66. Optionally use a heat shrink tubing for better cosmetic finish.

The Build

Please Note: Few pictures shown below are of different plane and for reference purpose only.

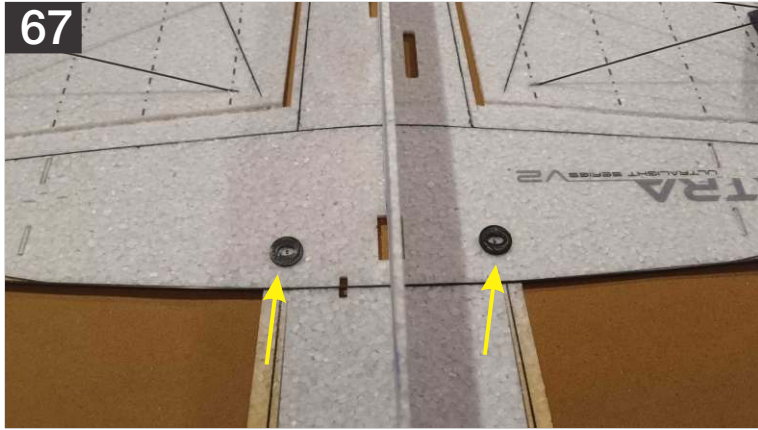

67. Glue the shown parts over the pre cut slots, for landing gear assembly.

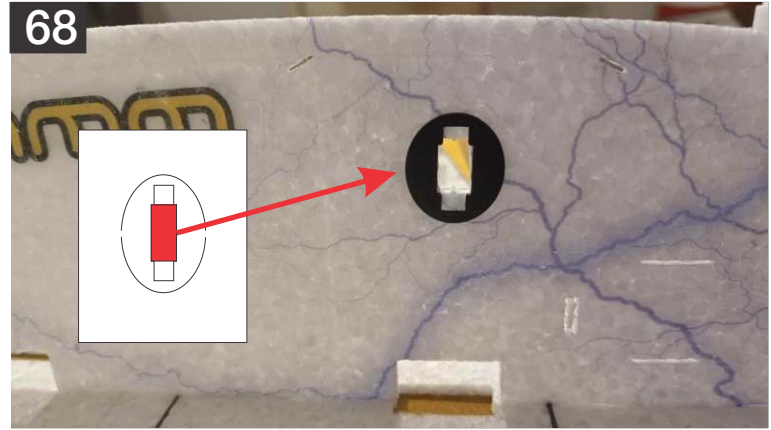

68. Glue the shown parts over the pre cut slots using the HV CA and cure everything together using the kicker. Match the shown red area with the pre cut slot in the EPP.

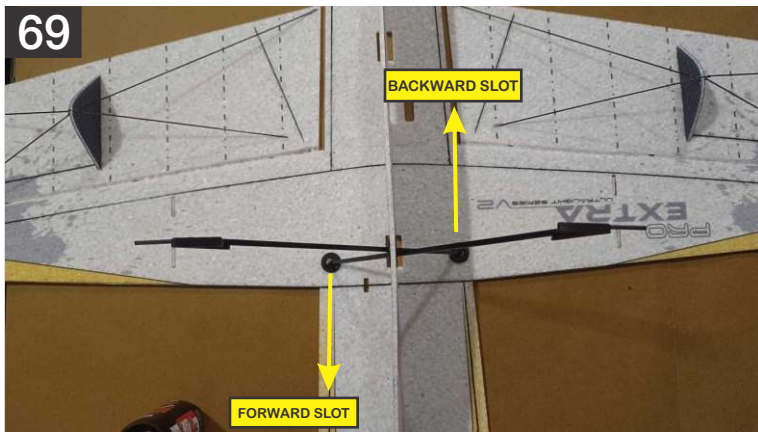

69. Install the undercarriage that we have prepared like shown in the above image. Both wings are having different positioning of UC slots with 3mm difference.

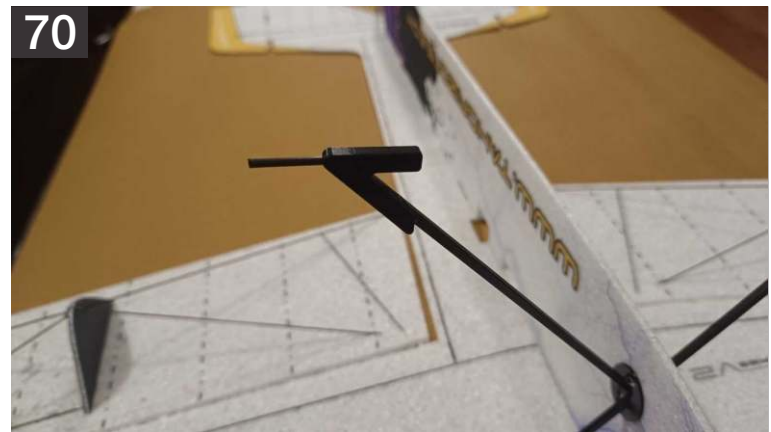

70. Make sure you have used the right orientation of the gear while installing them.

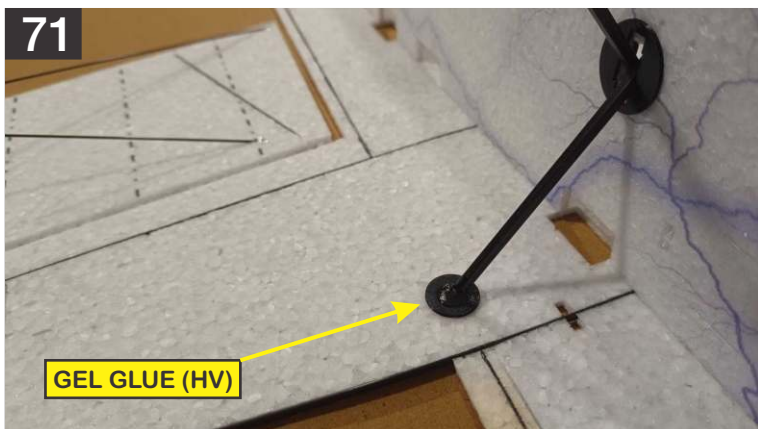

71. Put a drop of HV CA over the joints and spray everything together.

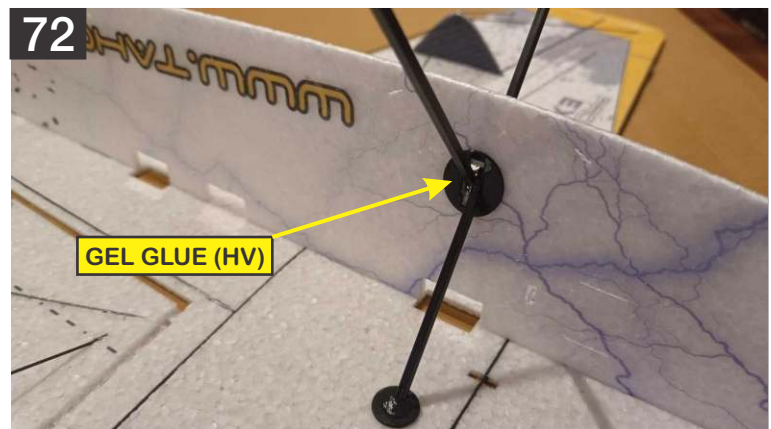

72. Put a drop of HV CA over the joints and spray everything together.

The Build

Please Note: Few pictures shown below are of different plane and for reference purpose only.

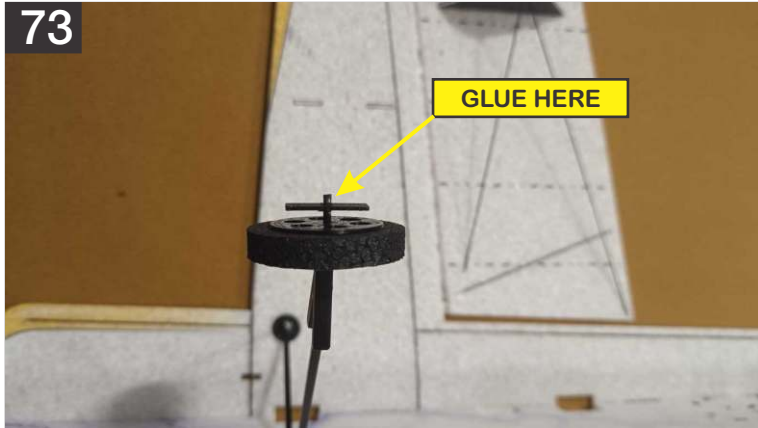

73. Install the wheel over the shaft, make sure it is spinning freely, after this slide in the wheel stopper. Put a small drop of HV CA over the shaft and wheel stopper joint.

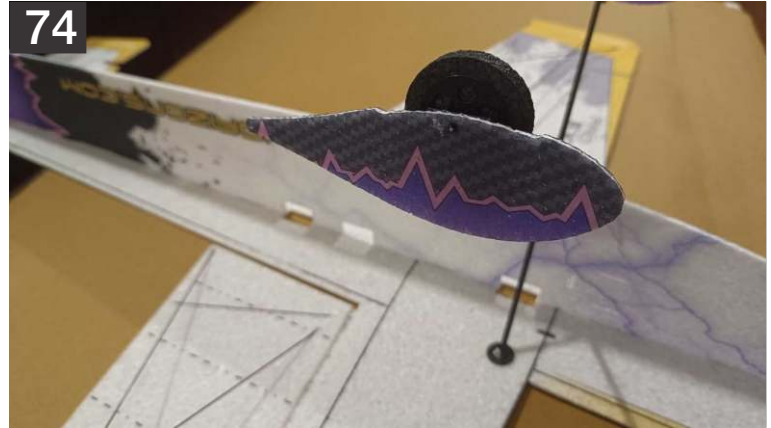

74. Glue the wheel pants on wheel stopper using the HV CA.

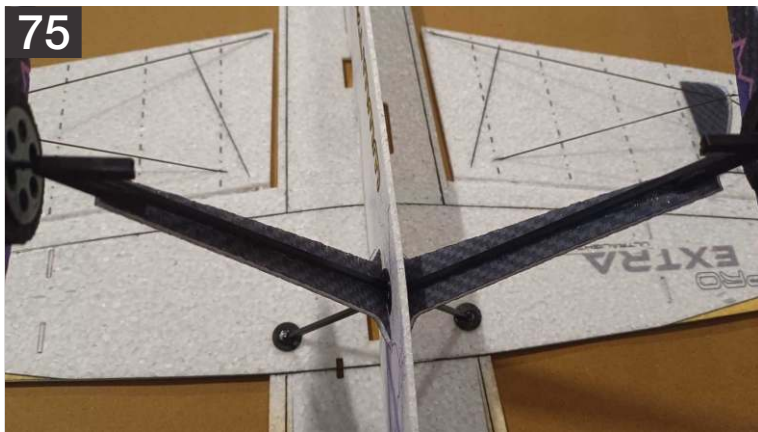

75. Locate the landing gear cover, glue it over the CF Undercarriage.

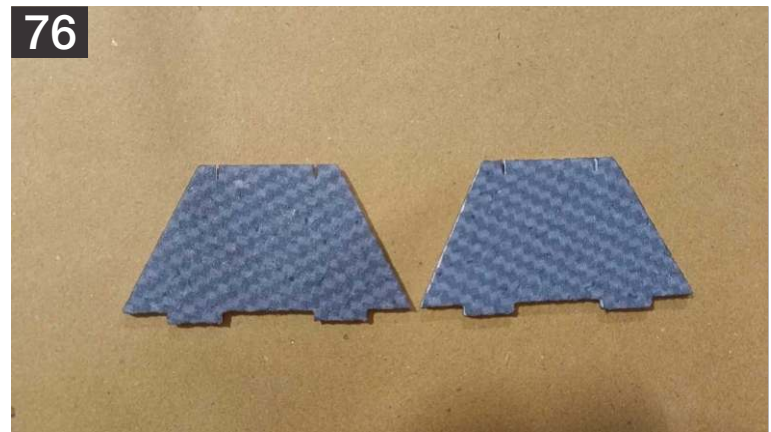

76. Truss braces on the under side of the Wing can be installed next, locate the above parts for the next process.

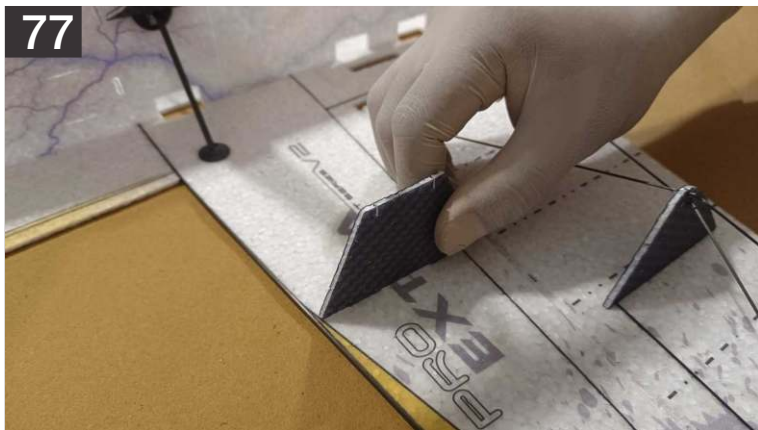

77. Install one on each side as shown, make sure they are fully engaged into their respective slots.

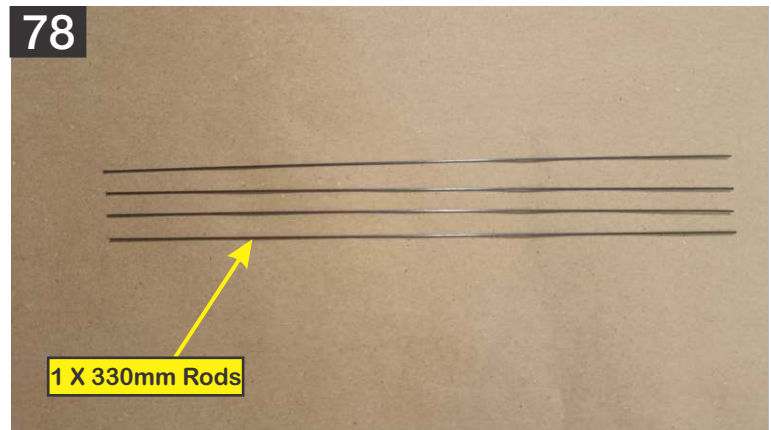

78. Again, all the wing and fuselage trussing is done using the 1mm rod, Cut length of 330mm X 4 from the supplied 1000mm rods for the next process.

The Build

Please Note: Few pictures shown below are of different plane and for reference purpose only.

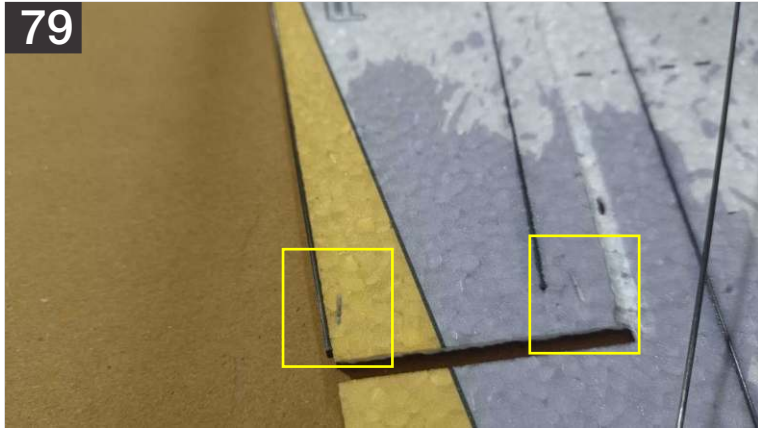

79. Locate the pre cut small slits on the wing tips, 2 slits on both the ends, to insert the rods into.



80. Do not use any glue until the step that calls for it. The object will be for the rods to be installed as shown above. Start by making sure the wing is flat.



81. The last ends of the two pieces should engage into the slots just behind the undercarriage.

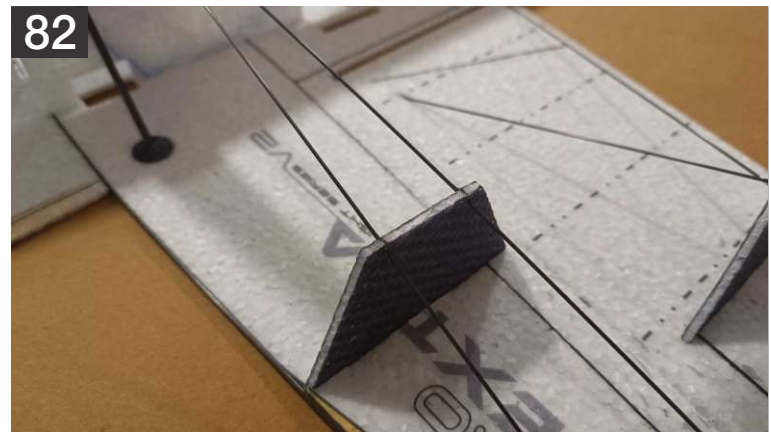

82. Route them thru the slits in the truss brace. They will fit down into the slit about 1/8 inch.

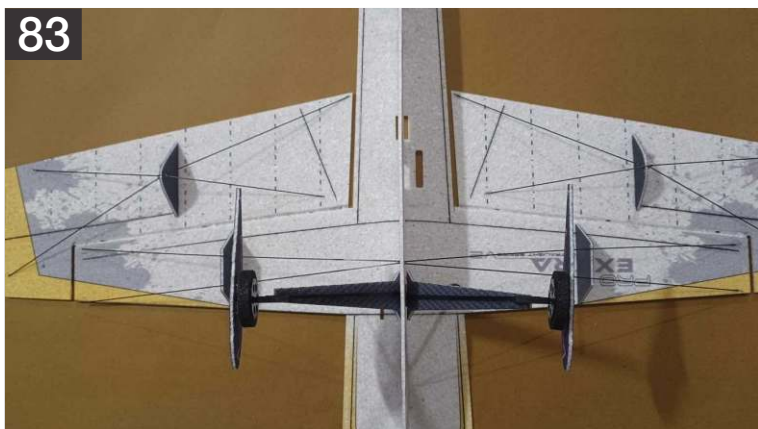

83. Position the carbon rods for the other wing and then at each of the points where the carbon and foam meet, put a drop or two of thin CA and set with kicker.

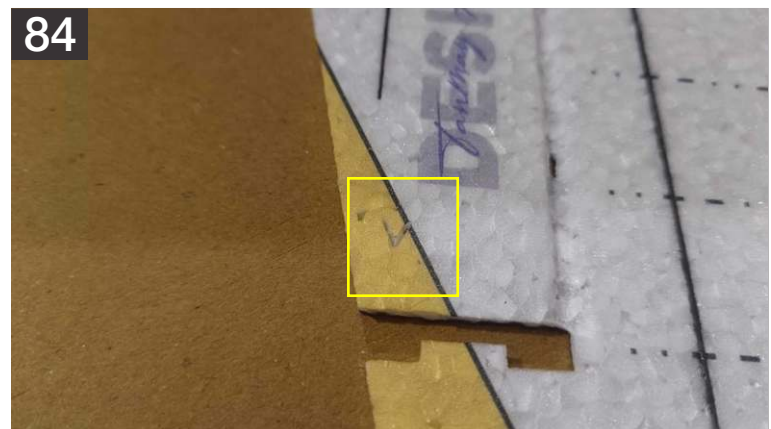

84. Up Next is the fuselage trussing. Locate the pre cut small slots all over the tail, horizontal and vertical profile sections.

The Build

Please Note: Few pictures shown below are of different plane and for reference purpose only.



85. Up Next is the fuselage trussing. Locate the pre cut small slots all over the tail, horizontal and vertical profile sections.



86. Up Next is the fuselage trussing. Locate the pre cut small slots all over the tail, horizontal and vertical profile sections.

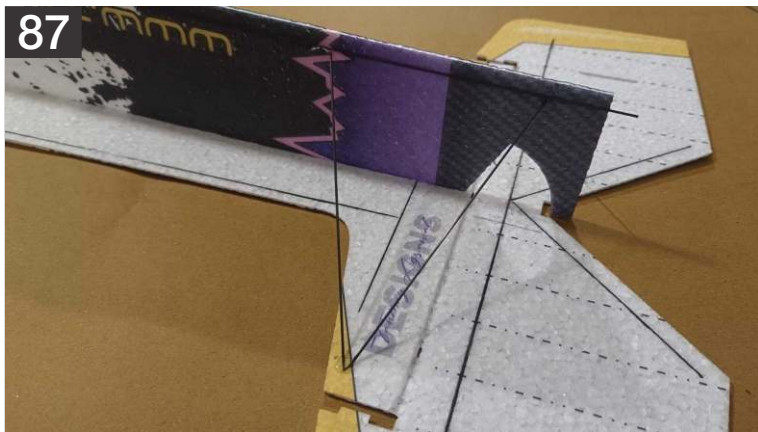

87. Start by cutting the supplied 1000mm 1mm rods into sizes shown on the page 4 of exploded view. Start installing them from the back.



88. Carbon rod needs to sit couple of mm into the pre cut slot into the foam before gluing, Just put a small drop of HV Cyno to glue it.

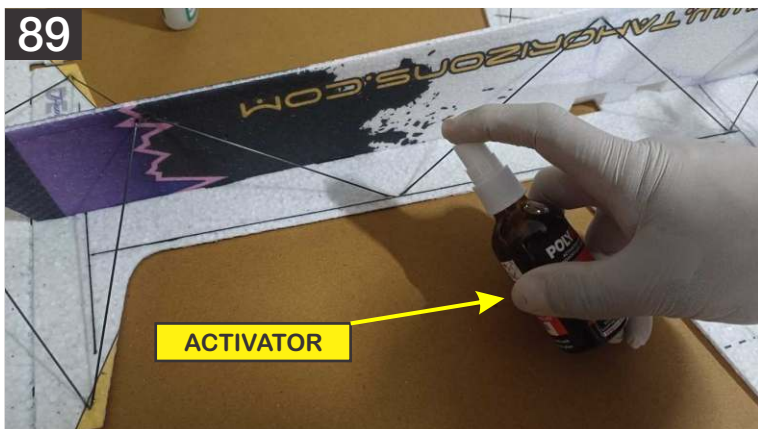

89. Use a spray activator to cure it.

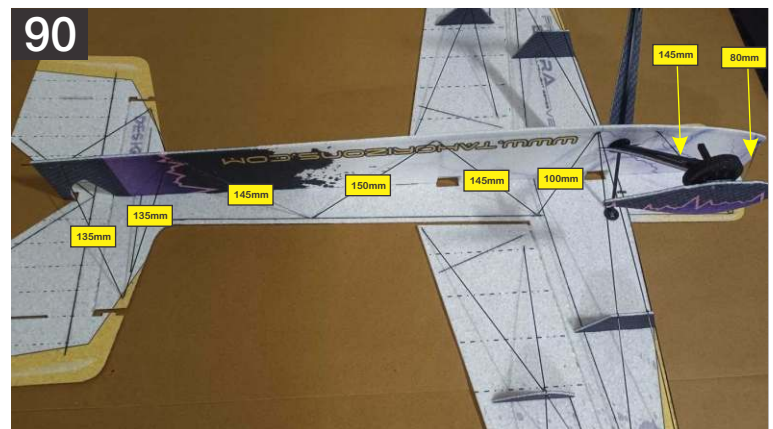

90. Repeat the step for the other side as well, Please refer to the (Page 4) of exploded view and above image for the length references.

The Build

Please Note: Few pictures shown below are of different plane and for reference purpose only.

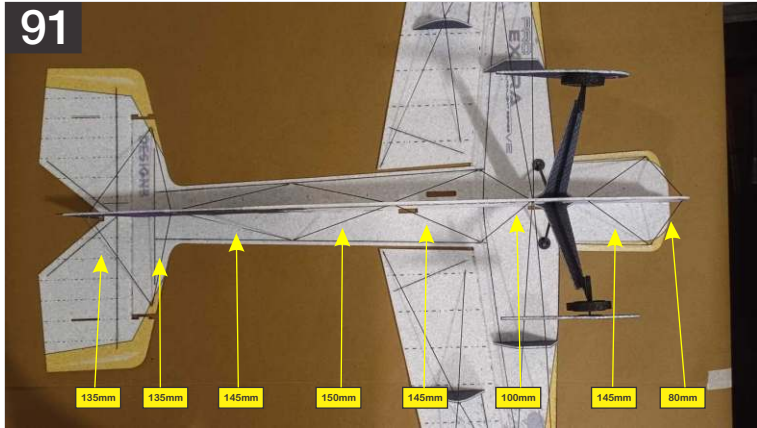

91. Please refer to the (Page 4) of exploded view and above image for the truss length references.

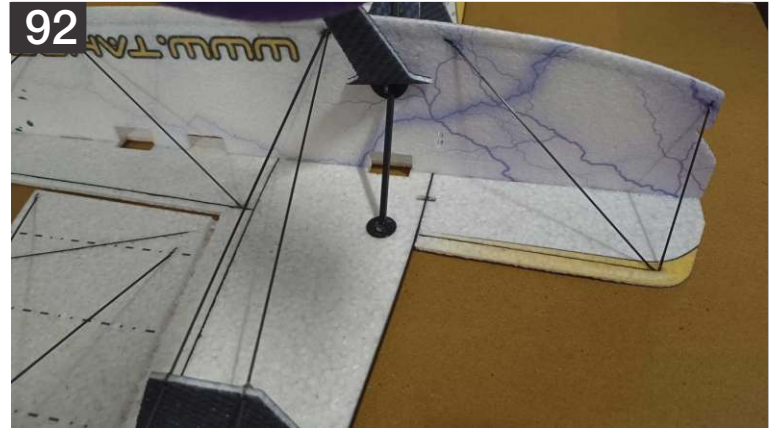

92. Please refer to the (Page 4) of exploded view and above image for the truss length references.



93. Locate the above 3 pcs servo arm extenders.



94. Install the extenders over the stock plastic servo arms using the small screw. Wrap with thread for more strength if desired



95. Here are all servo arm extenders are installed over the stock servo arms.

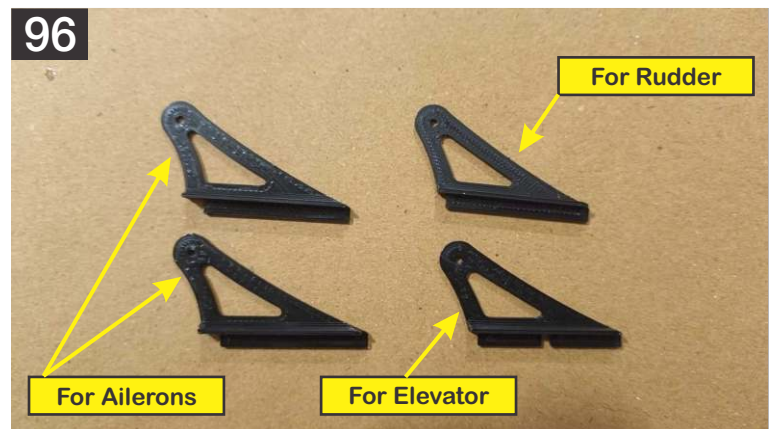

96. Locate the control horns, for elevator control horn you will notice a small square shaped cutout on the underside. This is meant to be placed around the spar of the elevator that was installed earlier. **Aileron control horns are also little bigger in height than the rudder horn.**

The Build

Please Note: Few pictures shown below are of different plane and for reference purpose only.



97. You will be required to widen down the aileron horn slot next to longer carbon rod slot, shown in the above image.

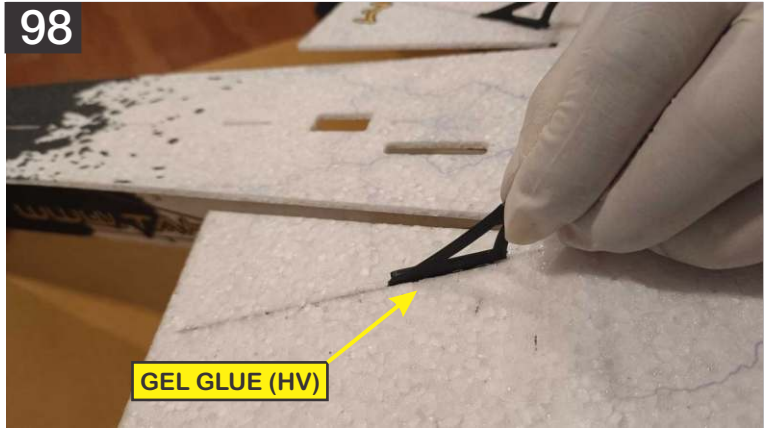

98. Install the horn into the slotted area that is a little wider. Make sure the hole of the horn is over the center of the hinge line.



99. Glue the elevator horn shown in the image in the precut control horn slot using HV CA. Make sure it sits right to the bottom of EPP Surface.



100. Time to install the servos, put the aileron servo in place and glue it.



101. Glue the rudder servo in place.

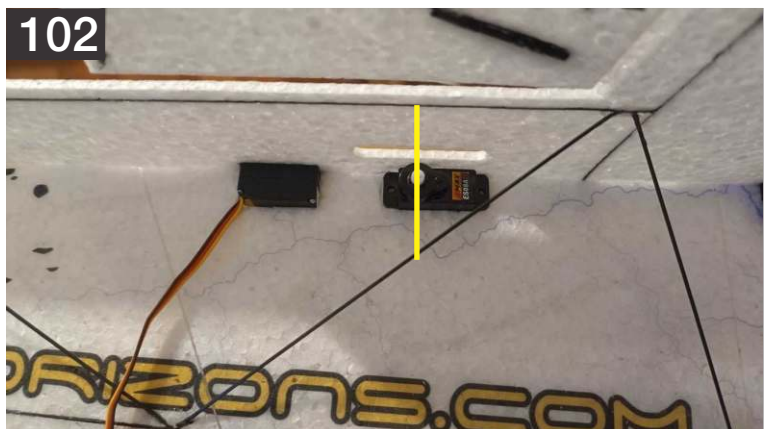

102. Glue the elevator servo in a direction in which the arm hub matches the center line of pre cut elevator arm slot.

The Build

Please Note: Few pictures shown below are of different plane and for reference purpose only.

103



103. Ailerons and Ele/Rud uses the different dia control rods, for ailerons we use 1.5mm rods and for ele/rud 1.2mm rods, hence control links for both are different.

104



104. Screw the 1.5mm dia control links over the aileron servo arm as shown above.

105



105. Screw the 1.5mm dia control links over the aileron control horn as shown above.

106



106. With the servo centered, Install the dual servo arm over it, check the orientation shown in the above image.

107

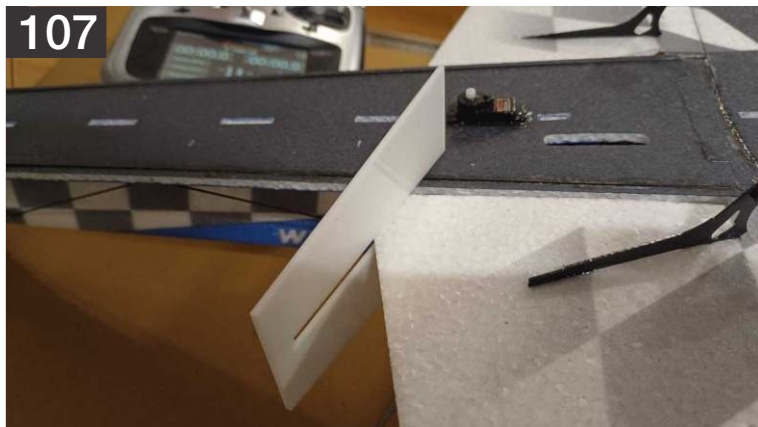

107. Use the assembly jig to center the ailerons and align it with the horizontal profile section for the final installation of the control rod, Locate the 1.5mm 100mm aileron control rod, glue it on the one side, using thin CA or optionally HV CA. Make sure you have servo arm centered.

108

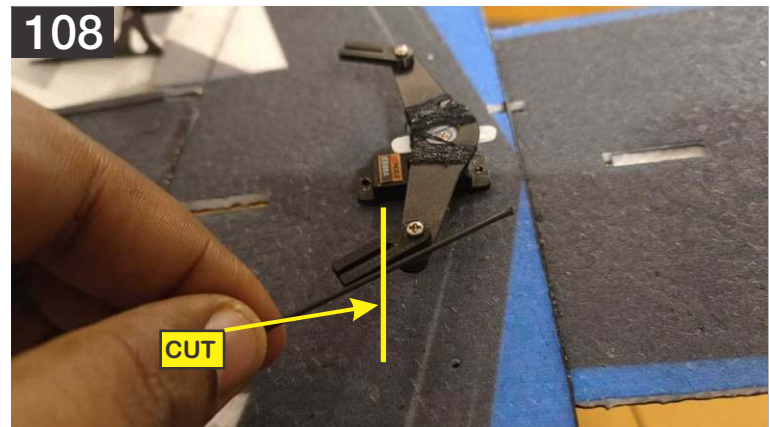

108. Cut the rod at the position shown in the above image to fit in the quick link.

The Build

Please Note: Few pictures shown below are of different plane and for reference purpose only.

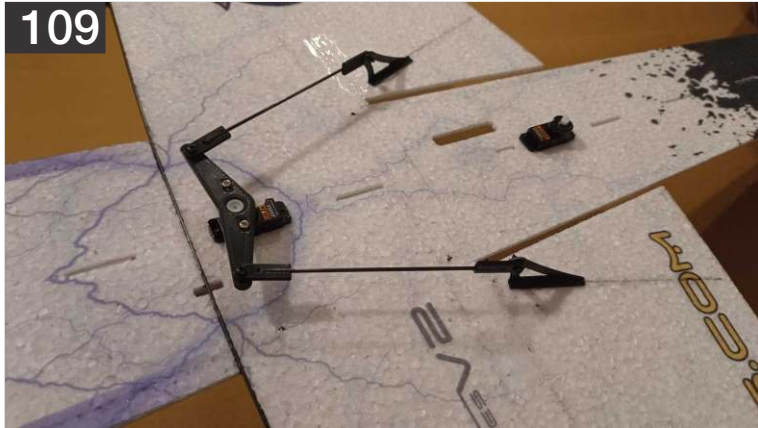

109. Repeat the process for other side. Above is the finished linkage setup with aileron centered and rod well fitted and glued in both the quick links.



110. Locate the 1.2mm control links for elevator and rudder.



111. Elevator linkage, Make sure you have the servo centered before moving further with the setup, check the orientation shown in the above image.



112. Screw the 1.2mm dia control links over the both elevator control horn and servo arm as shown above.

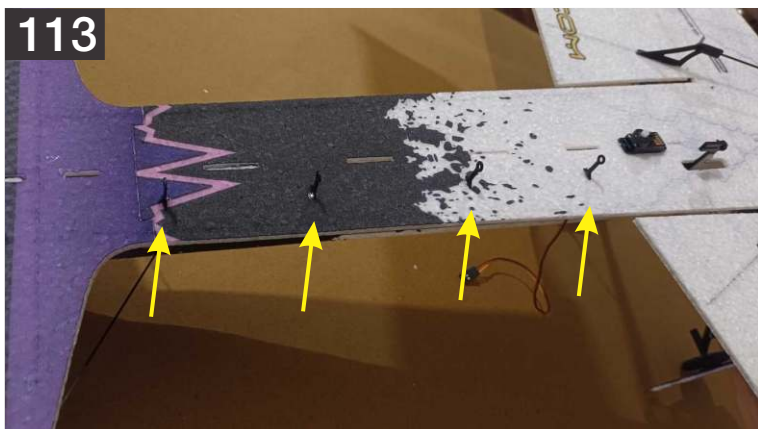

113. Before moving to elevator linkage setup, glue 4pcs pushrod guide into the pre cut slots.

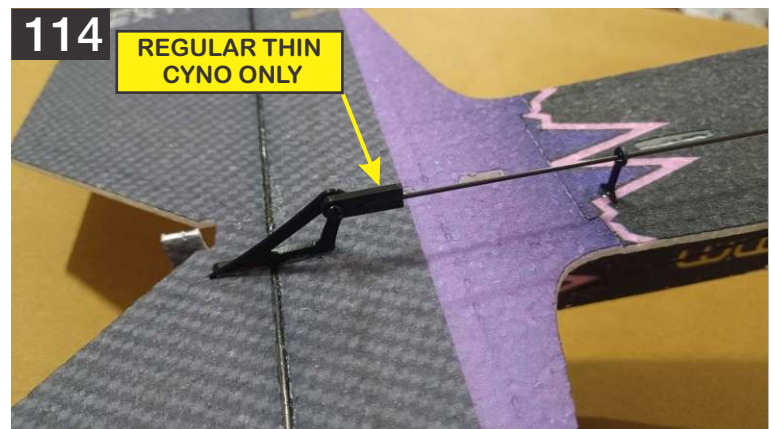

114. Notice how the elevator rod is slid in the pre glued pushrod guides, Glue the Elevator control rod on the one side, using thin CA or optionally HV CA.

The Build

Please Note: Few pictures shown below are of different plane and for reference purpose only.

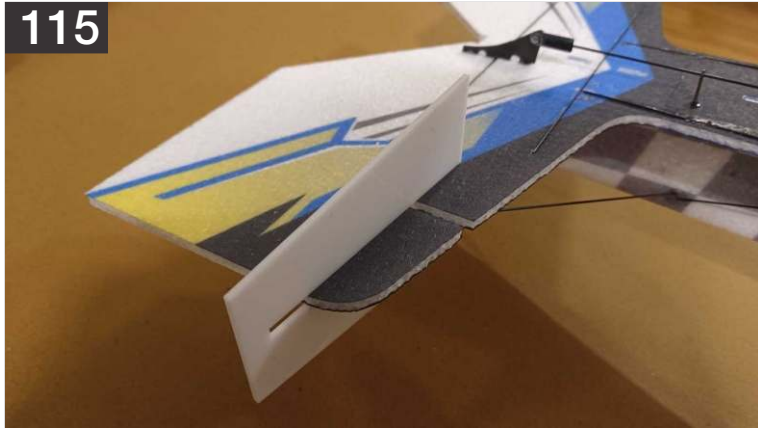

115. Use the assembly jig to center the elevator.

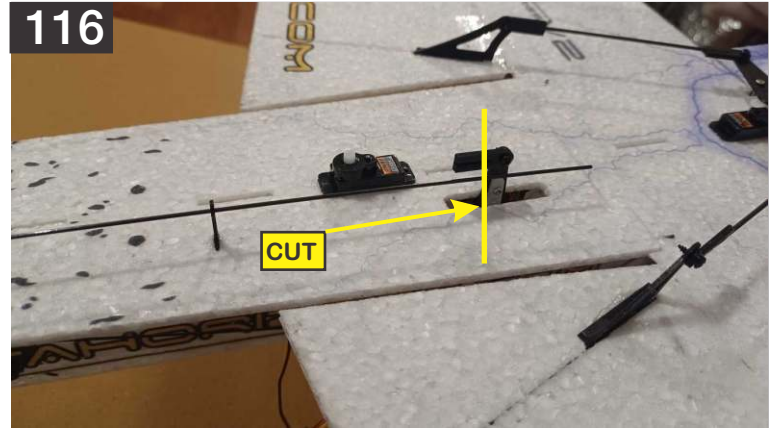

116. With the jig in place, Cut the rod at the position shown in the above image to fit in the quick link.

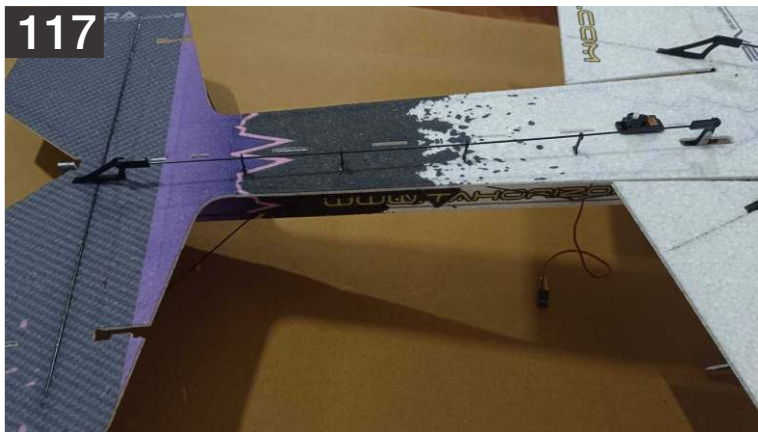

117. Above is the finished linkage setup with elevator centered and rod well fitted and glued in both the quick links with all the guides in place.



118. Dry fit the top part of the fuselage, trim any slots if needed.



119. Once the aileron and elevator linkages are set up, use the same process as gluing the bottom of the fuse to glue the top of the fuselage into place. Engage all the tab and slots. Press firmly along the length of the fuselage to make sure all areas are fully seated. Check that the top piece is square and straight. Tweak if necessary to make it true.



120. Note that there is a small area behind the elevator that should mate up as well.

The Build

Please Note: Few pictures shown below are of different plane and for reference purpose only.

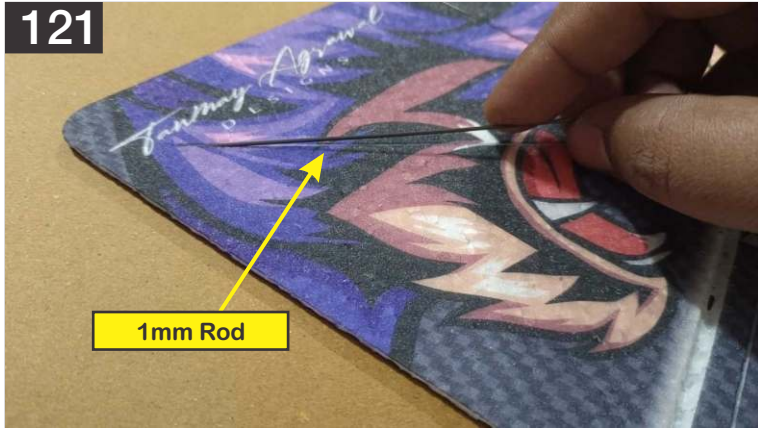

121. Next up is the rudder, cut the required length and glue the 1mm rod into the pre cut grooves as shown in the above image.



122. Glue with thin CA and set with Kicker. Don't forget to use the butter paper underneath when gluing with thin CA.



123. Shown above is the reinforced rudder ready for gluing, please refer to page 4 of (Exploded view) for more info on rod cut length.

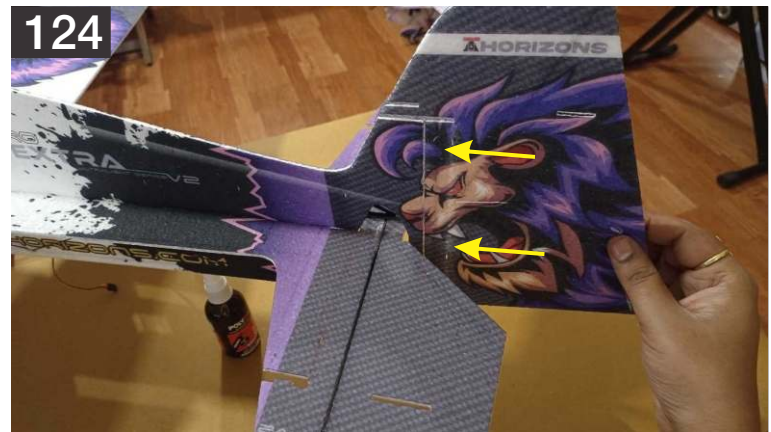

124. Glue the rudder using the HV CA shown in the above image.

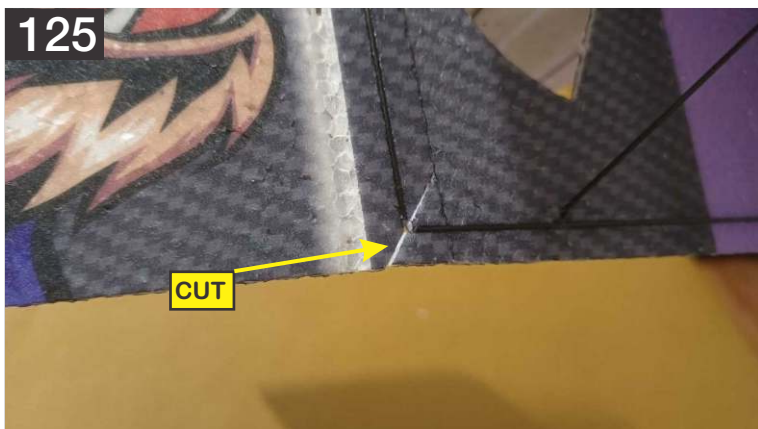

125. Glue the area of the spar that were left previously glue free, make a 25mm slant cut for gluing the tail skid as shown in the above image.



126. Glue the supplied 60mm flat piece of carbon as the tail skid.

The Build

Please Note: Few pictures shown below are of different plane and for reference purpose only.

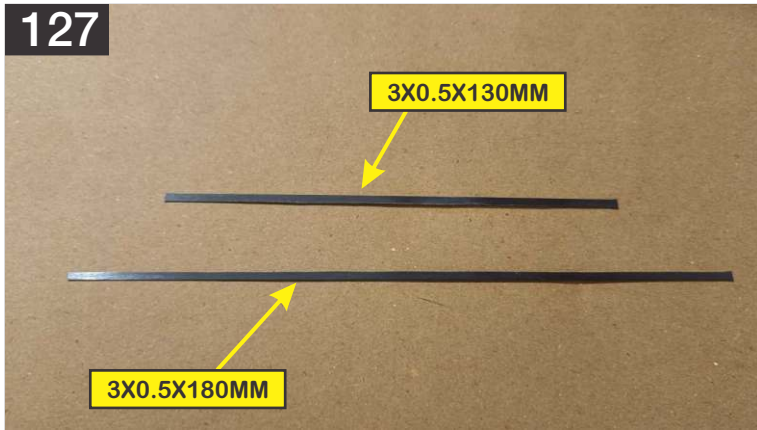

127. Locate the 3X0.5X180mm and 3X0.5X130mm flat carbon stripes for fuselage reinforcement.

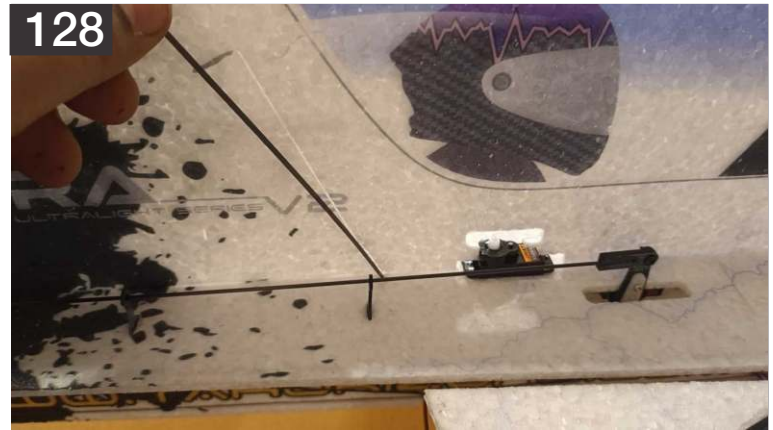

128. Starting with the 180mm long piece, slide it into the slot as shown. Note it may be necessary to clean a little glue out of the slot where the fuselage pieces meet up.



129. Use a thin cyano and activator to glue it.



130. Install the 130mm long piece as was just done with the rear piece.

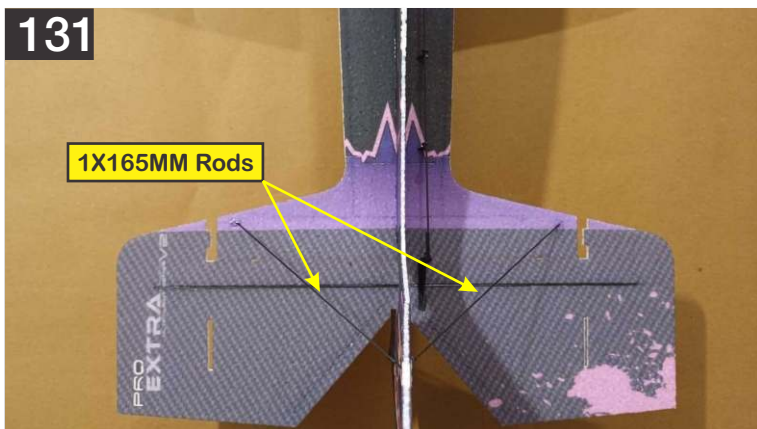

131. Cut down 2 X 165mm rods from the 1mm rod, the 2 carbon rod will go on each side of the fuselage. It will be used to strengthen the horizontal stab and vertical stab.

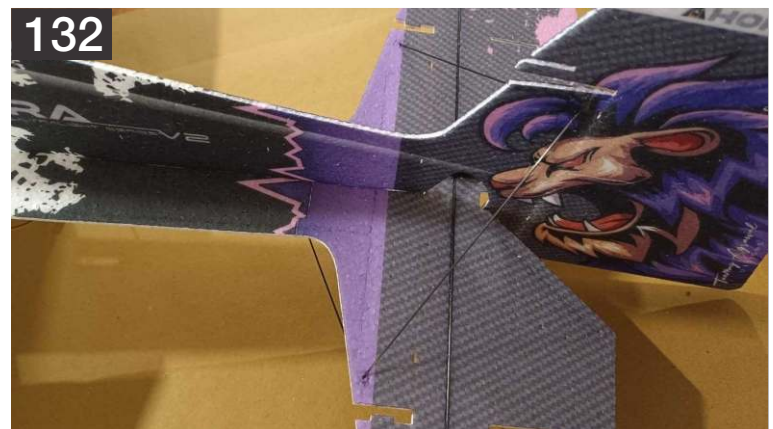

132. Here is an another view.

The Build

Please Note: Few pictures shown below are of different plane and for reference purpose only.

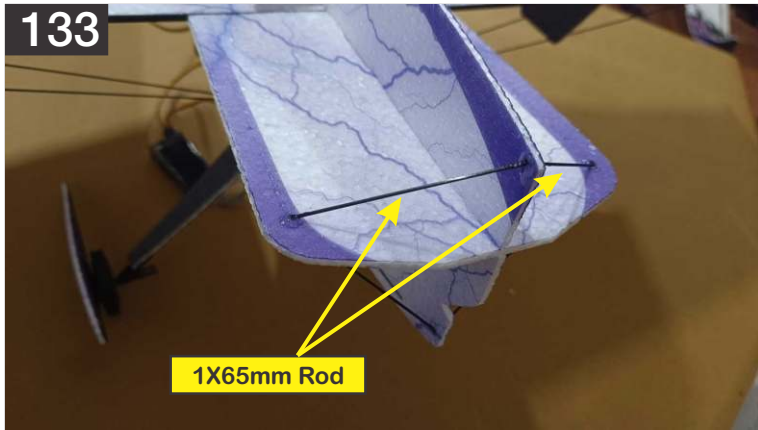

133. Cut down the 2 pieces 65mm length rod from the supplied 1mm rod, and glue them in place like shown in the above image for motor mount reinforcement.



134. Above is the finished linkage setup with rudder centered and rod well fitted and glued in both the quick links with all the guides in place. Use the same process like we did in previous linkage setups.

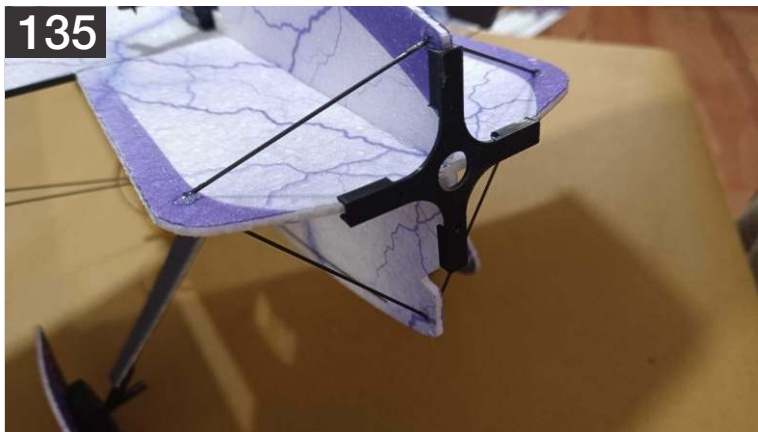

135. Shown above is the motor mount glued, making sure everything is flush and lined up correctly. After that Install the motor on it.

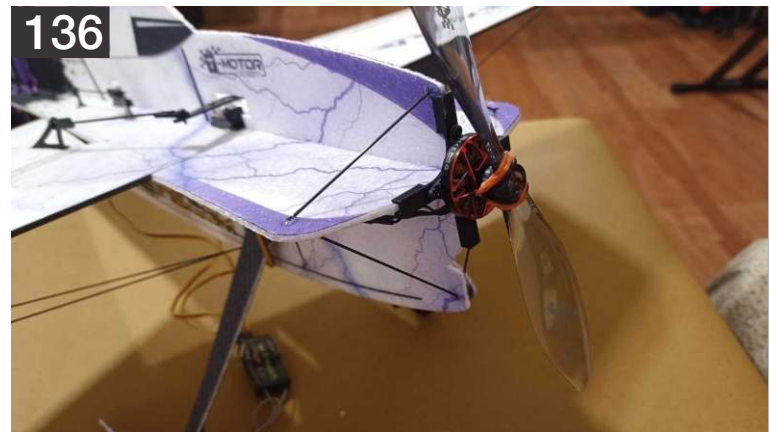

136. Enlarge the pre cut holes over the mount according to need and install the motor on it.



137. Notice above the plate glued onto the side of the fuselage. This can be used to mount the electronic speed controller.

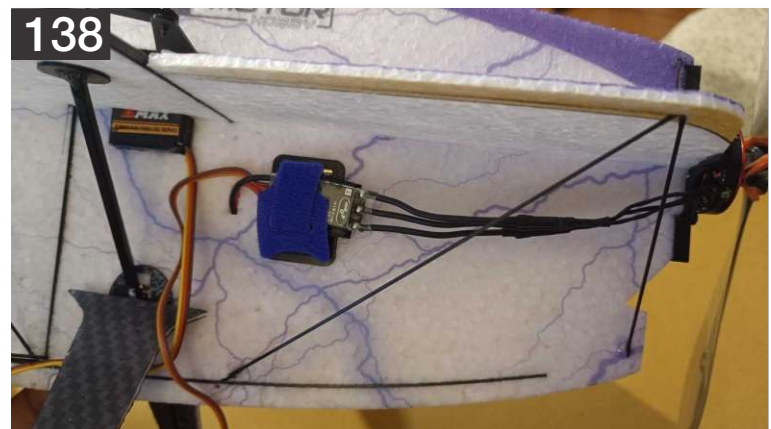

138. Notice above the plate glued onto the side of the fuselage. This can be used to mount the electronic speed controller.

The Build

Please Note: Few pictures shown below are of different plane and for reference purpose only.

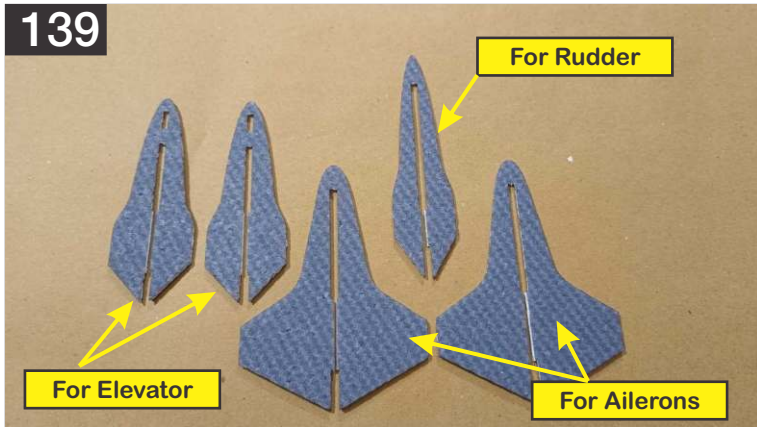

139. Locate all the black SFG pieces pictured above.



140. Test fit it into the slots on the ailerons. Sometimes a little trimming is needed. Once happy with the fit use either thin CA or HV CA to attach the piece.



141. Test fit it into the slots on the elevators. Sometimes a little trimming is needed. Once happy with the fit use either thin CA or HV CA to attach the piece.



142. Test fit it into the slots on the rudder. Sometimes a little trimming is needed. Once happy with the fit use either thin CA or HV CA to attach the piece.

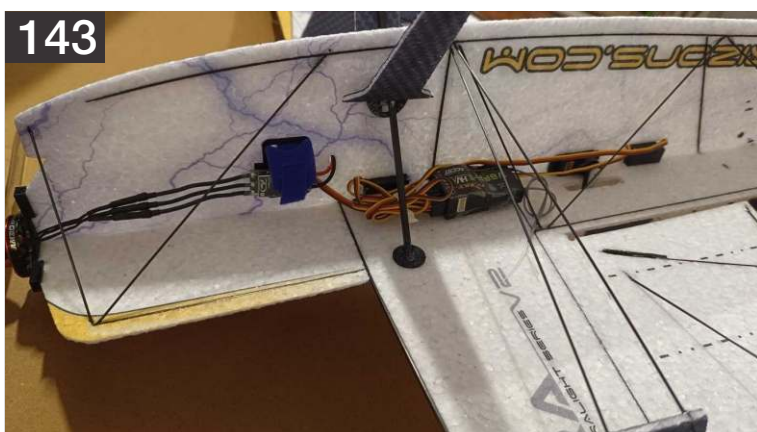

143. Here is the complete picture of receiver setup. Set up your radio as per the suggestions given a little later in this manual, check all the control directions and motor rotation.

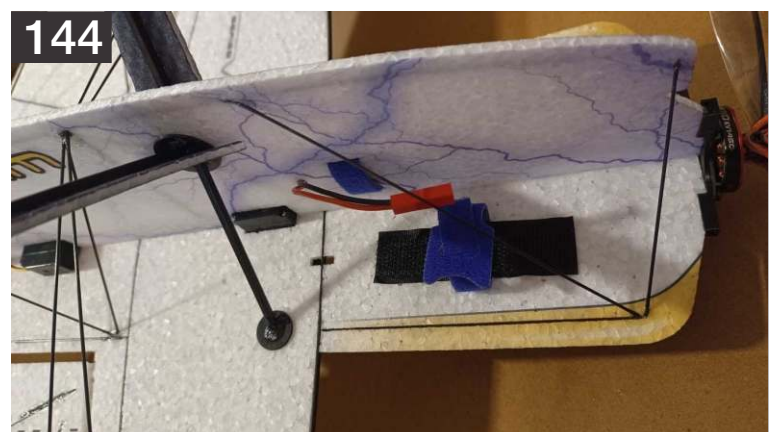

144. The long piece of velcro along with the strapping velcro mounted above is the location of the battery for this setup

CENTER OF GRAVITY

CG 230mm



Initial CG is located 230mm from the nose of the aircraft (Not from the motor)

CONTROL THROWS

Extreme & 3D:

Ailerons - approx +/- 45 deg
Rudder - approx +/- 45 deg
Elevator - approx +/- 45 deg
Expo to suit

Beginner & Sport:

Ailerons - approx +/- 20 deg
Rudder - approx +/- 20 deg
Elevator - approx +/- 20 deg
Expo to suit

In order to achieve the control throws as described for "Extreme & 3D", it is imperative that the control surface, linkages, rod ends, etc, all move freely over the entire range, including range end points.

Failure to do so will result in damage to either the servos or mechanical components

Thank You..

Thank you for your purchase at TA Horizons. We sincerely hope that our products can provide the same thrill to you that we experience in this hobby. The motive of this project is to spread the outcome of my love for teaching and share my knowledge and experience with every enthusiast out there.

Please feel free to contact us regarding any type of question about this kit.



Happy Landings,
Tanmay Agrawal
TA Horizons