

TURNIGY[®]
power systems

RoHS FC CE 



INSTRUCTION MANUAL

TURNIGY[®]
power systems



CONTENTS

Foreword	2
Important statement	2
1. Definition of Q-Bot Micro flying orientation	4
2. Standard equipment	4
3. Setup of the Receiver	5
4. Transmitter diagram	6
5. Instruction for Charger	7
6. Steps of flight	7
7. Flight Control diagram	8
8. Steps of Ending flight	10
9. Addition Instruction	11
10. Exploding View	12
11. Parts list	13
12. Accessories list	14
Specifications and Features	15

Foreword

Dear Customers:

Thanks for purchasing Turnigy radio control aircraft product. In order to quickly and safely master the operation of the Q-Bot Micro, please read the manual carefully and then keep it in a safe place for future consultation and reference.

Important Statement

1. Important statement

Q-Bot Micro is a high risk hobby, whose flight should be kept far away from other people. Mis-assembled or broken main frame, defective electronic equipment, and/or problematic radio system will lead to unforeseen accidents such as bodily injury or property damage. The pilot **MUST** pay attention to the flight safety and **UNDERSTAND** his responsibility for accidents caused by his carelessness.

A. Far away from obstacles and people

Q-Bot Micro in flight has risk of uncertain flight speed and direction which is potentially dangerous. When flying, please keep your Q-Bot Micro far away from people, high buildings, high-tension lines, etc, and avoid operating in rain.

B. Keep away from humidity

Q-Bot Micro should be kept away from humidity and vapor because its complex, and precise electronic components and mechanical parts may be damaged.

C. Proper operation and maintenance.

Please use Turnigy original spare parts to upgrade, modify or maintain your Q-Bot Micro in order to ensure its safety. Please operate your Q-Bot Micro within the range or functions permitted. It is forbidden to use it outside of the safety laws or regulations.



D. Avoid flying alone

At the beginning of learning about radio-controlled flight there are some difficulties to overcome. Please avoid flying alone. Invite experienced pilots to guide you (two of the most effective methods to practice are via a PC flight simulator and/or under the supervision of a skilled pilot).



E. Safe operation

Please fly your Q-Bot Micro according to your physical status and flight skills. Fatigue, listlessness and mis-operation will increase the possibilities of accidental hazard.



F. Away from highly spinning parts

Please keep pilot, people and object away from the spinning blades of high main rotor and tail rotor.



G. Protect from heat

An Quadcopter Q-Bot Micro is made from metal, fiber, plastic and electronic components, etc. Please keep away from heat and sunshine in order to avoid distortion, even damage, caused by high temperatures.



2. Attention before flight

- Ensure the battery packs of both transmitter and receiver and fully charged (saturated).
- Ensure both the throttle stick and the throttle trim of your transmitter stay at the lowest positions before operation.
- Please strictly obey the order of turn on and turn off before operation. When starting your flight, please turn on your transmitter first, and connect the power cable of your Q-Bot Micro last. When finishing your flight, please disconnect the power cable of your Q-Bot Micro first and turn off your transmitter last.
- An upset in the order of connection may cause your Q-Bot Micro to lose control. Please cultivate a correct habit of turn on and turn off.

1. Definition of Q-BOT Micro Orientation

We define the orientation for Q-Bot Micro in order not to cause confusion in the following descriptions. That is to say, the tail boom of Q-Bot Micro is facing the pilot (tail in), and its head facing forward (front of pilot). The left hand of pilot is the left side of Q-Bot Micro, the right hand of pilot is the right side of Q-Bot Micro. Its head is the front and its tail boom is to the back. The direction in which main body of Q-Bot Micro is facing up, and its skids are facing down.

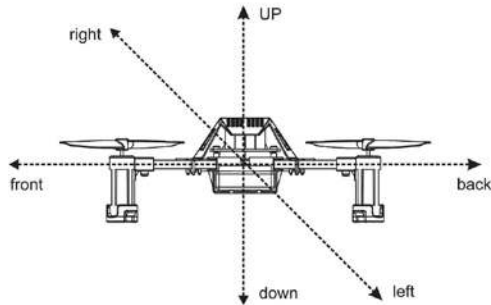

2. Standard equipment



Quadcopter Q-Bot Micro



Li-polymer battery pack



Charger



Main rotor blades.
cross screwdriver



Manual



Radio Adapter

3. Setup of the Receiver

3.1 Receiver features

- (1) It adopts 2.4G spread spectrum technology.
- (2) Integrated design of 3-Axis gyro and 3-Axis accelerator

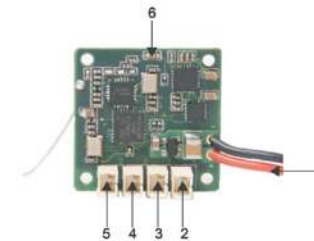

3.2 Function of receiver

S/N	Name of short	Full name	Function
1	Power wire	Connect to the lipo battery	charge
2	Right front motor	Connect to the right front motor wire	The bind plug face towards right
3	Right back motor	Connect to the right back motor wire	The bind plug face towards right
4	Left back motor	Connect to the left back motor wire	The bind plug face towards right
5	Left front motor	Connect to the left front motor wire	The bind plug face towards right
6	Signal indicator light	Show the bind status(green)	binding

Note:

Green light: When in the code pairing status, the receiver indicator will flash green.;After code pairing successfully the green light turns solid; If the green light turns off means failure bind or has not receive the signal.

4. Radio Adapter Instruction

1. Radio Adapter Chart

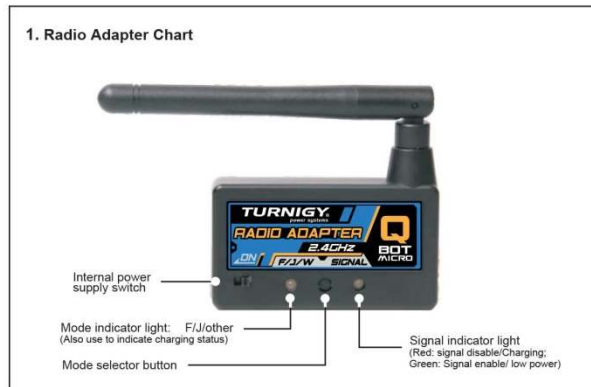

2. Parameters

Sealed battery Specification: 3.7V Li-Po battery 120mAh
 Operating voltage: 5 ~ 12V.DC
 Operating Current: ≤ 100 mA
 Operating frequency: 2402 MHZ ~ 2477 MHZ
 Spread Spectrum mode: FHSS
 Number of frequency channels: 20
 Hopping Rate: 240 Jump/s

3. Charging operation:

First put the Internal power supply switch to OFF position, no LED lights on adapter bright this time, then connect adapter to a computer (or the other power supplier equipment) using USB wire, this time, Signal indicator light starts to flash and Mode indicator light shows charging status: red means charging,turning to green means charging is over.

4. Normal use operation:

- 1.Supplying power of radio itself (eg: JR / Futaba) the Adapter internal power supply switch to OFF state. Properly connected adapter signal cables and power cables.(JR signal cable connecting the remote control DSC interface, and power cable to connect to DC charging port) (Futaba' s connection is a combination of signal cable and power cable to connect simulator interface)
- 2.If no power from radio, switch the adapter internal power supply to on state properly connected adapter and remote control of the DSC interface
- 3.Under normal circumstances the adapter light is green , when red check the signal cable if is normal, as well as check the remote control to set the modulation mode to PPM format. Set the types of remote control through switch the button of adapter , the status indicator (Model)Futaba, (green) JR (ed), WAKERA (no light).

Notice:

- 1.There is one 3.7 V Li-po Battery sealed in the RF Module. If the radio controller you use can supply the power to the RF Module, please turn off the sealed battery to off status.
2. Please pay attention to the battery power when you use sealed battery of RF Module, if the green light is flashing, please stop to play and charge the battery.

5. Advice Parameters to Radio Adapter

1. Advice parameters to RF Module with JR radio controller

Fist, set JR radio controller to Plane Mode, then adjust the radio controller to PPM transmit format.



First, set FUTABA radio controller to Plane Mode, then adjust the radio controller to PPM transmit format.



[END POINT]

1 AILE	100% / 100%
2 ELEV	100% / 100%
3 THRO	100% / 100%
4 RUDD	120% / 120%
5 GEAR	100% / 100%

[REVERSE]

1 AILE		NOR
2 ELEV		NOR
3 THRO		NOR
4 RUDD	REV	NOR
5 GEAR		NOR

FUTABA radio controller

6. Instruction for Lipo Charger

1. Battery Charger is suitable for 1 or 2 cell (3.7V) Li-ion or li-polymer battery. Please plug the pin of your battery into the jack of the Battery Charger.
2. Please plug the pin of your battery into the jack of the USB first and then connect to the power. Otherwise, the LED may not become red and the voltage may be higher than 3.8V. You need to disconnect the USB power supply and reconnect it.
3. When USB power supply is well connected and battery is charging, the LED will become red. After your battery is full charged, the LED will not become Green.

7. Steps of flight

7.1 Installation of battery pack

Install the battery to the pack



1. Install the battery pack in the battery compartment



2. Connect the power cable of Q-Bot to receive signal from transmitter

7.2 Matters needing attention

(1) Please follow these rules: "Open the radio first, connect the Quadcopter Q-Bot Micro power last". After opening the radio power button, please connect the Q-Bot Micro power in 10S, the signal indicator light begins flashing, the light will solid after 1-3 seconds, and the four motors will self-checking rotation, then the receiver has received the signal of the radio successfully, binding finished.

(2) If more than 10 seconds passed before the power cable was connected binding will fail. When binding fails, disconnect the battery.

7.3 Troubleshooting a flashing receiver LED after connecting the power cable

Possible causes	Solutions
Code pairing failed	Turn transmitter off then on and re-connect Q-Bot Micro power cable
The throttle stick of transmitter is not at the lowest position	Pull down the throttle stick to the lowest position and re-code pair
The transmitter battery is low and empty	Replace transmitter battery and re-code pair (re-bind)
The Q-Bot Micro battery is low and empty	Replace the Q-Bot Micro battery with a fresh pack and re-code pair
No function in receiver or transmitter	Replace faulty receiver or transmitter and re-code pair

8. Flight Control Diagram

8.1 Flight in Normal Status

Mode 1 (throttle stick at right hand)

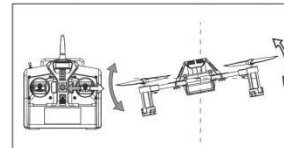

1. When moving the aileron stick left or right, the Q-Bot Micro accordingly flies left or right.

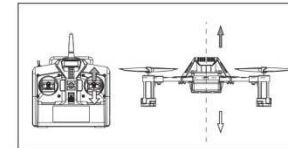

2. When moving the throttle stick up or down, the Q-Bot Micro accordingly flies up or down.

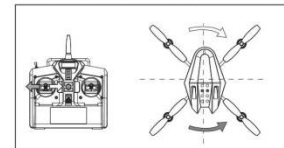

3. When moving the rudder stick left or right, the Q-Bot Micro accordingly flies left or right.

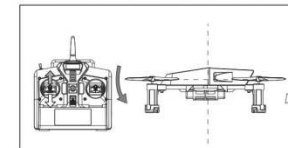

4. When moving the elevator stick up or down, the Q-Bot Micro accordingly flies forward or backward.

Mode2 (throttle stick at left hand)

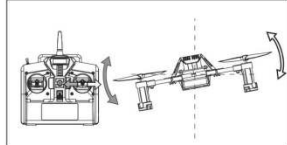

1. When moving the aileron stick left or right, the Q-Bot Micro accordingly flies left or right

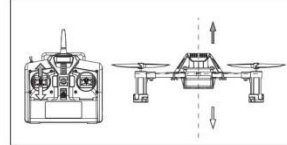

2. When moving the throttle stick up or down, the Q-Bot Micro accordingly flies up or right

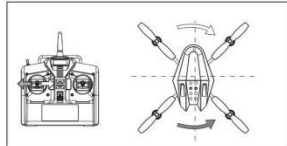

3. When moving the rudder stick left or right, the head of Q-Bot Micro accordingly flies left or right

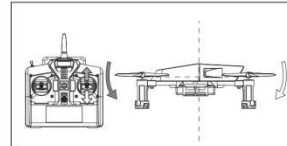

4. When moving elevator stick up or down, the Q-Bot Micro accordingly flies forward or backward.

8.2 Roll flight practice

Q-Bot Micro can finish excited stunts actions, such as the front and back, right and left rolls.

Matters need to be attention when the first flight

1. Choose a spacious ground with soft grass to practice.
2. Select roll flight mode
3. Advise beginner to increase servo distance of ELEV and AILE of the transmitter to 100%-110%. And can adjust according to personal skill level. The default setting is 100%.
4. Practice of throttle stick: when Q-Bot Micro roll from normal status, the throttle stick need to be pulled down slowly; push up the throttle when it exchanged normal status to roll. Please adjust according to personal skill level.

Mode 1 (throttle stick at right hand)

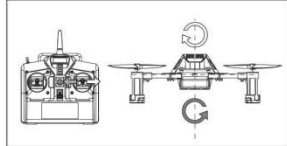

1. When moving the aileron stick left or right, the Q-Bot Micro accordingly rolls left or right..

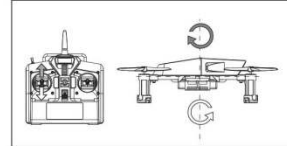

2. When moving the elevator stick up or down, the Q-Bot Micro accordingly rolls forward or backward.

Mode 2 (throttle stick at left hand)

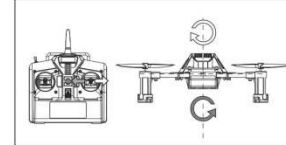

1. When moving the aileron stick left or right, the Q-Bot Micro accordingly rolls left or right.

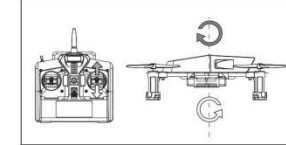

2. When moving the elevator stick up or down, the Q-Bot Micro accordingly rolls forward or backward.

9. Steps Of Ending Flight

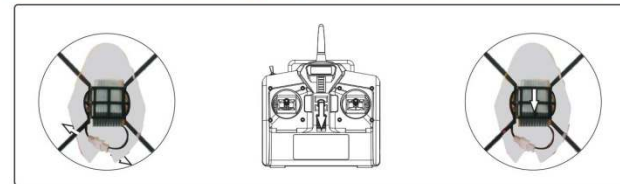

1. Disconnect the power cable of Q-Bot Micro

2. Turn off the transmitter

3. Remove the battery

10. Addition Instruction



1. The front propellers are in orange color while the rear propellers are in black.
2. After connecting the power of the Q-Bot Micro, left rear / right front blade rotates clockwise, left front / right rear blade rotates Counterclockwise.
3. You can adjust the radio trim button(except the throttle trim) if the quadcopter flight drift.



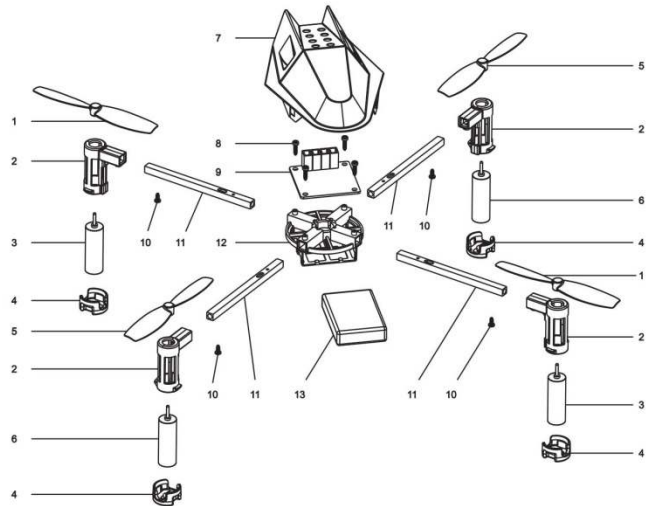



11. Exploding View



12. Parts List

NO	Part Name	Quantity
1	Quadcopter inverted blade	2
2	Quadcopter motor pedestal	4
3	Quadcopter inverted motor $\phi 7.0^* 20\text{mm}$	2
4	Quadcopter pedestal plug	4
5	Quadcopter positive blade	2
6	Quadcopter positive motor $\phi 7.0^* 20\text{mm}$	2
7	Quadcopter canopy	1
8	Quadcopter screws ST 1.2*5PA	4
9	Quadcopter receiver board	1
10	Quadcopter screws ST 1.2x3PA	4
11	Quadcopter carbon fibre pipe 3x3x50	4
12	Quadcopter pedestal	1
13	Li-po battery 3.7V 250mAh 25C	1

13. Accessories List

Quadcopter pipes 	Quadcopter pedestal 	Quadcopter green positive inverted blade 	Quadcopter motor pedestal 
Quadcopter motor pedestal plug 	Quadcopter Canopy 	Quadcopter positive motor 	Quadcopter inverted motor 
Quadcopter Lipo battery 	Quadcopter wire 	Quadcopter screws bag 	Quadcopter cross screwdriver 
Quadcopter Adapter 	Quadcopter Battery Charger 	Quadcopter receiver board 	
Quadcopter positive motor accessories 	Quadcopter inverted motor accessories 	Quadcopter black positive inverted blade 	Quadcopter orange positive inverted blade 

Q-Bot Micro



Specifications and Features

Specifications and features:

Overall Length: 127.7mm
 Overall height: 36mm
 All-up weight : 35g
 Main rotor blade Dia: 56mm
 Overall rotation Dia: 176mm
 Battery: 3.7V 250mAh 20c
 Radio controller: CY400
 Flight time: 6~7min

1. Adapt the newest stable six-axis system, high sensitivity and efficiency.
2. Mini body design, light and anti-throw
3. Stable flight, can realize front and back, left and right rolls



2.4GHz
FHSS

INSTRUCTION MANUAL

TURNIGY®
POWER BY DESIGN
