

AGE 14+

**TOP** RC HOBBY



# ***RIOT***

**R/C AEROBATIC SPORTS AIRCRAFT  
ASSEMBLY AND INSTRUCTION MANUAL**

[www.toprchobby.com](http://www.toprchobby.com)

## Warning

This radio controlled model is not a toy. It requires skill to fly and is not recommended for use by beginners without assistance from an experienced model pilot. It should not be operated by children without the supervision of a suitably experienced adult. TOP RC HOBBY reserves the right to modify the specification of this model at any time.

## Safety Precautions

1. Do not attempt to repair or modify this aircraft with non-factory parts.
2. Never fly this model over roads, railway lines, near to power lines, airports, do not fly this model in excessively strong winds, in the rain, or thunderstorms.
3. Do not fly or launch the model towards people.
4. Keep hands and face away from rotating propeller at all times.
5. We strongly recommend that all fixings and fasteners used in the construction of this model are checked regularly for integrity. Failure to do so could cause a crash, injury to yourself or others around you.
6. We only recommend the use of 2.4GHz radio equipment with this model.

## Disclaimer

1. This radio controlled model is not a toy. Used incorrectly it is capable of inflicting serious injury to persons or damage to property. The owner/pilot assumes all responsibility for any damage to persons or property resulting from the use of this product.
2. The manufacturer and distributor decline all responsibility for any liability arising from use of this product.
3. It is very important that you follow all instructions for assembling and setting up of this model. Failure to do so could result in a loss of control and possibly a crash.

## “EPOFLEXY”

“EPOFLEXY” is a very tough and durable material perfect for the manufacture of model aircraft. When using screwed fixings with “EPOFLEXY” components it is important to tighten the screws sufficiently to provide a firm fixing.

Excess tightening could result in the foam material becoming compressed, possibly damaging or distorting the part. Take care to ensure that all screws are tightened sufficiently to provide a firm fixing, but do-not over tighten. We recommend that all fixings are checked regularly for security and safety purposes.

## Overview

Thank-you for purchasing this radio controlled model aircraft. The RIOT offers a stunning combination of terrific looks and sensational flight performance. Manufactured from "EPOFLEXY" it is extremely robust, however, in the event of a "less than perfect" arrival, we supply a range of spares to get you flying again in the shortest time. It is capable of a wide range of amazing aerobatic manoeuvres to thrill the experienced pilot, but with reduced control throws it provides a solid and predictable flight performance, perfect for the sports flyer.

We are certain you will enjoy your new model, please take the time to read this manual thoroughly and understand its contents completely prior to commencing assembly.

## Key Features

- Powerful Brushless Motor
- 40A Brushless Electronic Speed Controller
- Efficient 2 Blade Propeller
- Pre-installed servos
- "Live" Control Surface Hinging
- Durable "EPOFLEXY" Construction
- Steerable Tail Wheel
- Superb Flight Performance
- High Brightness LED Lighting System

## Specification

Wingspan:	1400mm
Length:	1130mm
Weight:	1480g
Wing Loading:	40.3g/dm <sup>2</sup>
Motor:	3720-KV880 Out-Runner Brushless
ESC:	40A Brushless
Servos:	9g*2+17g*2
Battery Required:	2200 - 2400mAh 11.1v Li-Po (Not Included)
Recommended Battery:	2200mAh 11.1V 20C

## Assembly instructions

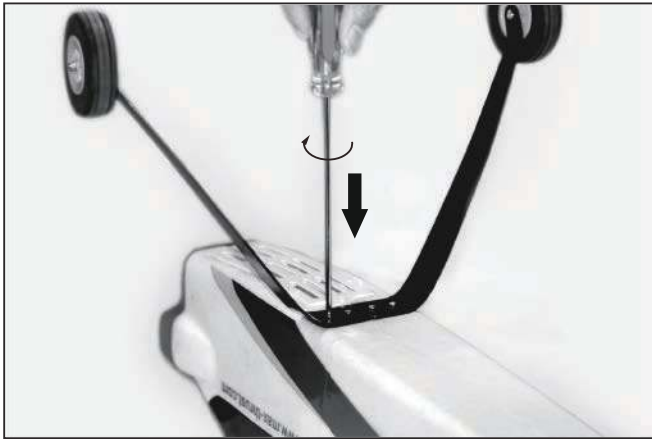

### 1. Undercarriage

Fix the undercarriage in position with the four 2.6 x 12mm self-tapping screws as shown, (image A). If the screws become excessively tight whilst fixing, simply back them off a turn or two, and then continue.

Note: The undercarriage legs are angled towards the front of the fuselage.



4 x Screw 2.6 x 12mm

### 2. Horizontal Tail-Plane

Remove the moulded tab at the end of the fuselage with a sharp knife. Slide the horizontal tail-plane into the fuselage slot as shown, (image B). Make certain that the holes in the tail-plane lineup with the corresponding fuselage holes. If desired, a small amount of foam glue can be used for maximum security.

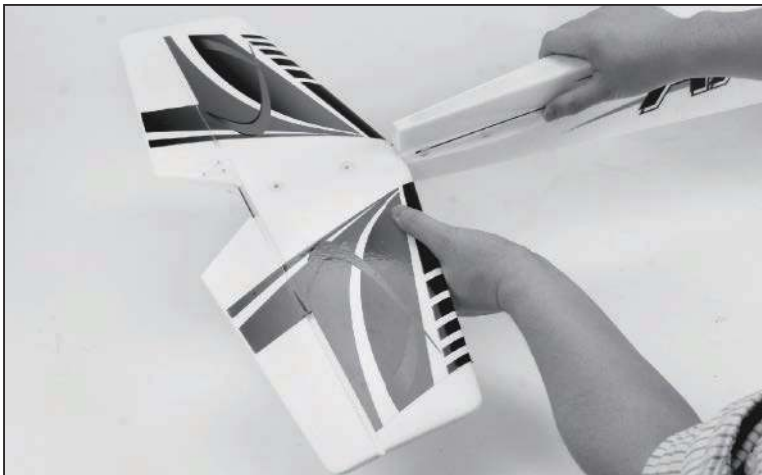

### 3. Vertical Fin & Rudder

Install the vertical fin and rudder assembly into the slot in the fuselage. Please make certain that the tail-wheel control wire is located correctly in the rudder slot as shown, (image C).

If desired, a small amount of foam glue can be used for maximum security.



#### 4. Tail-Plane Fixing

Fix the horizontal tail-plane and vertical fin in position with the two 2.6 x 35mm screws provided, (imageD). The screws must be tightened sufficiently to securely fix the parts in position, however be careful not to over-tighten the screws.

2xScrew2.6x35mm



#### 5. Tail Control Horns

Connect the rudder and elevator snap-links to their respective control horns as shown in images E&F. Minor adjustment to obtain perfect neutral positions of the control surfaces can be achieved by rotating the plastic link on the threaded portion of the control push-rod. Make certain the plastic link is securely “snapped” closed when connected to the control horn.

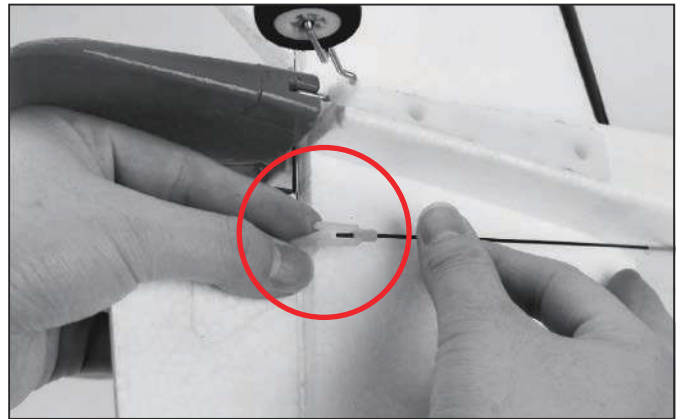
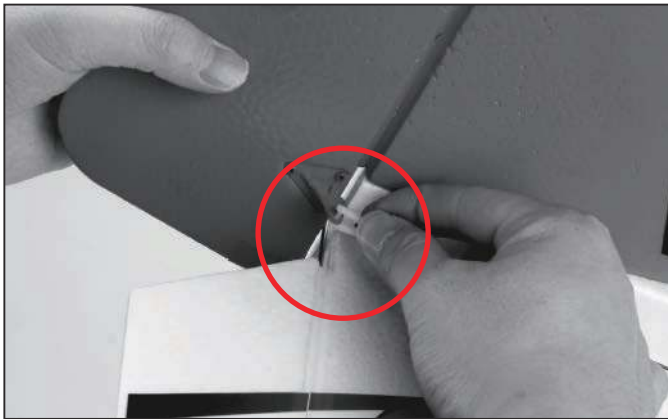

#### 6. Wing Assembly

Locate the 500mm aluminium wing joining spar and slide into the round aperture of one wing panel up to the centre locating collar. Locate the small plywood wing locking plate and insert into the rectangular aperture behind the main wing spar, (image G). Slide the remaining wing panel onto the exposed portion of the aluminium spar. The plywood locking plate will ensure perfect alignment of the two wing halves. Be certain that all wires are routed correctly via the moulded slots and do not foul the joint between the wing roots. If desired, a small amount of foam glue can be used for maximum security.

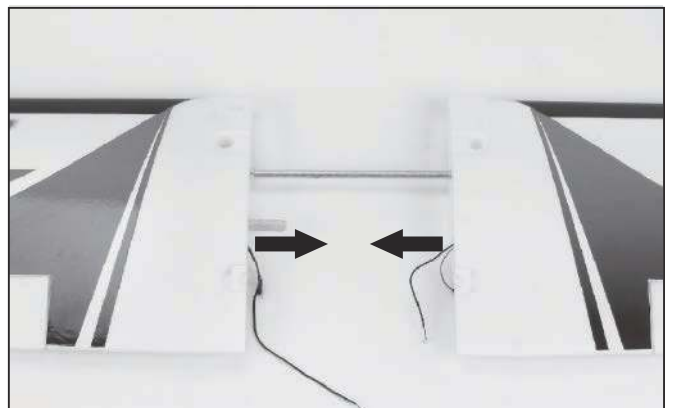

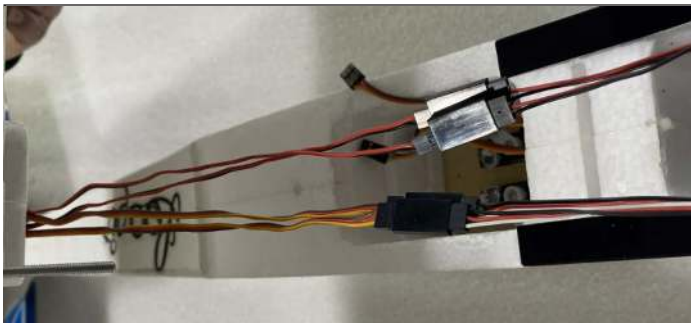

Please connect the 3-Pin wire leads for Aileron from the wings to the 3-Pin Y lead provided, and connect the 2-Pin LED wire leads from the wing to the 2-Pin Y lead provided. Pay attention to the polarity of this connection.

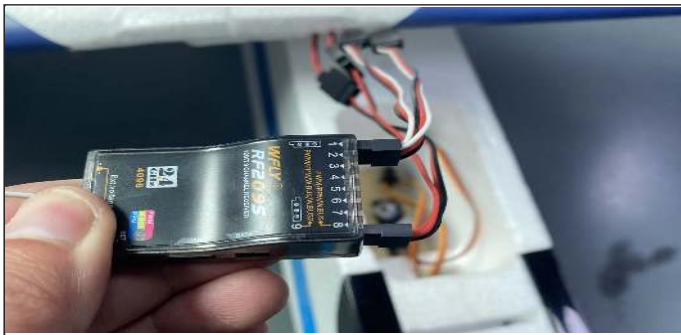

Please plug the 3-Pin Aileron Y lead to the Aileron channel of your receiver. And plug the 2-Pin LED Y lead to any other channel of the Receiver except for Aileron, Elevator, Throttle, Rudder channels. Please pay attention to the polarity of the connection.

## 7. Wing Fixings

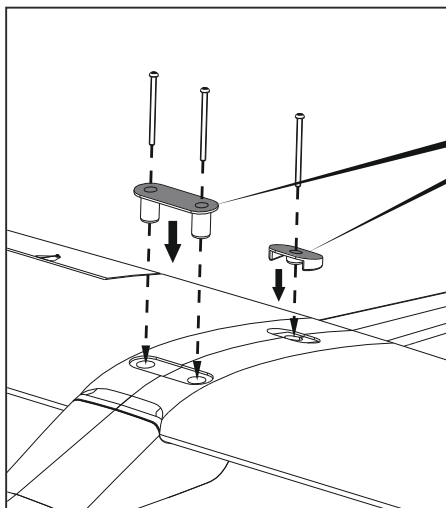

Note: The plastic connectors are angled for the wing camber.

1 x



1 x

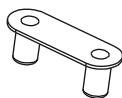

3 x Screw M4 x 50mm



Insert the front and rear plastic connectors into the wing, (image J). They are angled to provide a perfect fit. Make certain you have them located correctly! The wing can now be trial-fixed in position onto the fuselage using the 3 x M4 x 50mm screws provided.

## 8. Propeller & Spinner

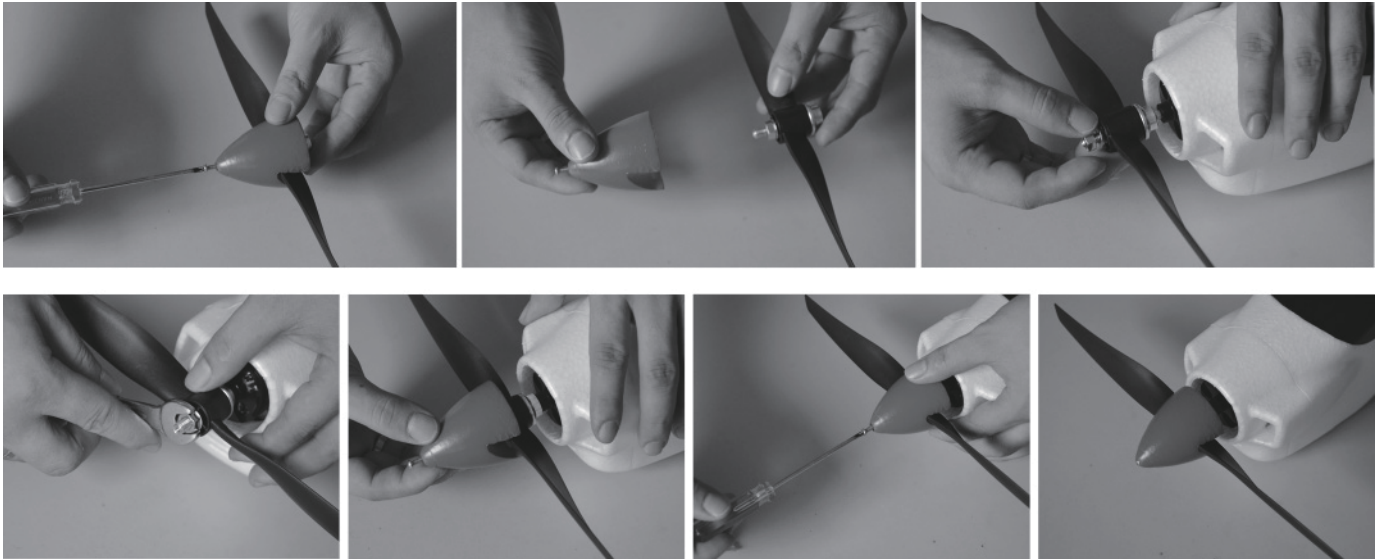

1. Please take off the propeller set from the package. Disassemble the spinner by screw driver.
2. Please install the assembled propeller to the motor shaft.
3. Lock the propeller by wrench.
4. Assemble the spinner.
5. Lock the spinner by the screw driver.
6. Assembly of propeller is finished.

Securely tightening the nut will clamp the adaptor to the motor shaft and fix the propeller in position. Note: Use of excessive force will cause damage to the aluminium adaptor.

Attach the front section of the plastic spinner and secure with the two screws provided.

**Note:** It is essential that the propeller is securely fixed. Failure to do so could result in serious injury.

## 9. Receiver Installation

Connect the speed controller to the throttle channel of your receiver, (not included). This wire is easily identified, it is the only one that is routed from the front of the model.

Connect the rudder and elevator servos to the corresponding channel outputs of the receiver and connect the plug from the aileron “Y” lead to the aileron channel output. There is a moulded recess in this compartment which is sufficient to accommodate most popular 2.4GHz receivers; however there is ample room elsewhere to locate yours if it does not.

We recommend that it should be securely positioned with self-adhesive “Velcro”.

You must adhere to the receiver manufacturer recommendations regarding positioning and aerial routing.



## 10. Battery Installation

The battery compartment is accessed by gently squeezing the two raised white tags and lifting the rear of the front hinged cover, (image M). Your flight battery, (not-included) can easily be installed and connected to the factory fitted “T” style connector, (image N). Make certain the battery and cover are both secure before flight, the battery compartment has been made bigger to except larger batteries if required, if your battery is loose in the compartment please use some foam / sponge packing to keep it in place.

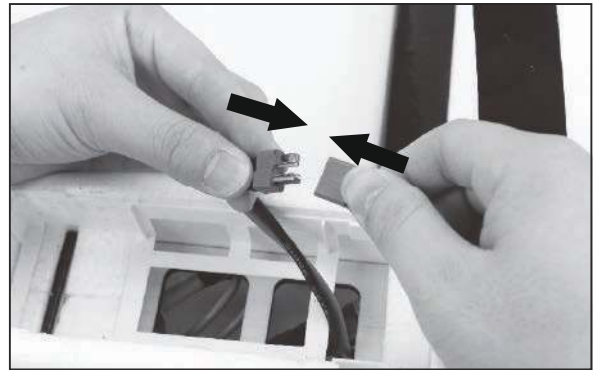
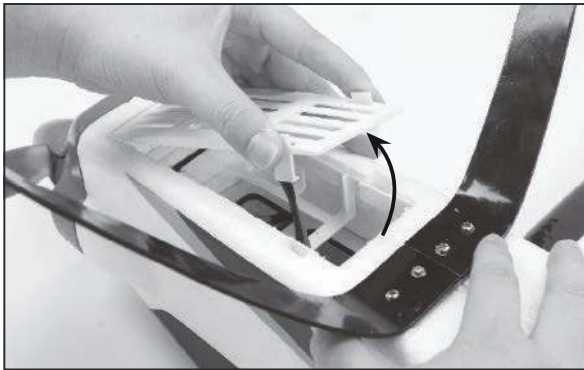

## 11. Control Surfaces

Check that all control surfaces are centred and responding correctly to transmitter inputs. Adjustments can be made to control surface centres by carefully rotating the plastic control horns on the threaded portion of the metal control rods. Use the servo reversing function on your transmitter for any control that is not responding in the correct sense to control inputs. Make certain that all plastic links are securely “snapped” closed and that all control surface hinges are secure. Use a small amount of foam glue if any hinges are not firmly attached.

## 12. Propeller Rotation

Double-check that the propeller is securely fixed and it is rotating in the correct direction, (image O).

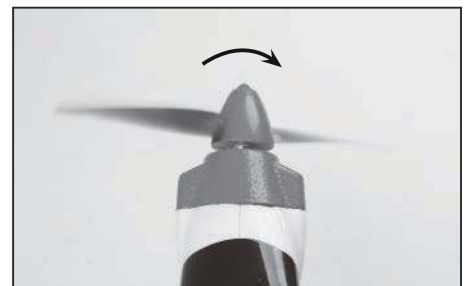

## 13. Centre of Gravity

It is vital that you check that the centre of gravity is correct. Failure to do so could result in a complete loss of control. We recommend the balance point of the model, complete with battery, should be 75 -90mm back from the leading edge of the wing for initial flights, (image P). Very experienced pilots may wish to move the balance point further back after initial flight testing.

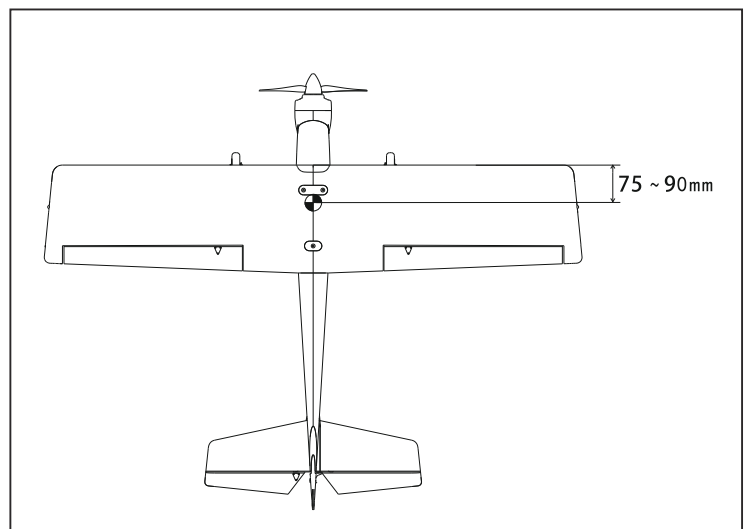



## 14. Control Surface Deflections

We make the following recommendations for control surface deflections. Experienced pilots may wish to increase these movements after initial flight testing.

Ailerons: 10mm each way.

Elevator: 10mm each way.

Rudder: 12mm each way.

We hope you enjoy many happy and safe flights with your new TOP RC HOBBY RIOT model aircraft.

Check-out other aircraft in the TOP RC HOBBY range at your local model dealer, or by visiting [www.toprchobby.com](http://www.toprchobby.com)



### Spare parts list

A full range of spare parts is available for the Riot. Please contact your model dealer or visit [www.toprchobby.com](http://www.toprchobby.com) for further details



NO: top04201

Fuselage



NO: top04202

Main wing set



NO: top04203

Horizontal wing



NO: top04204

Rudder

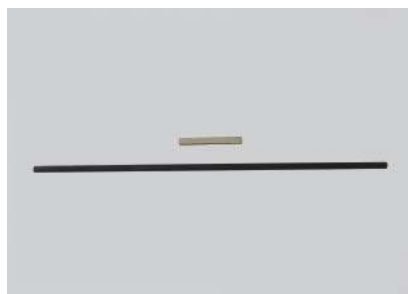

NO: top04205

Wing connection rod



NO: top04206

Cowl

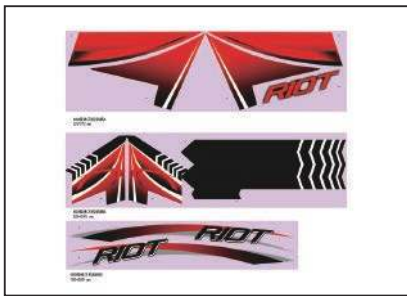

NO: top04207  
Sticker(Red)



NO: top04208  
Spinner



NO: top04209  
Propeller(12 x 8)



NO: top04210  
Propeller adaptor

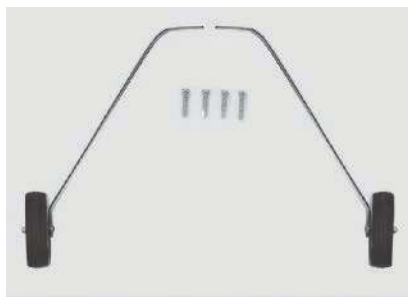

NO: top04211  
Main landing gear



NO: top04212  
Motor 3720-880KV  
outer runner brushless



NO: top04213  
ESC 40A brushless



NO: top04214  
Servo(9g,extension cable  
length 435mm)



NO: top04215  
Servo(17g,extension cable  
length 180mm)

**TOP** RC HOBBY



**RIOT**

[www.toprchooby.com](http://www.toprchooby.com)

Tel: 0086-(0)755-27908315

Fax: 0086-(0)755-27908325

**Made in China**