

Slow Poke™ Sport 40

INSTRUCTION MANUAL

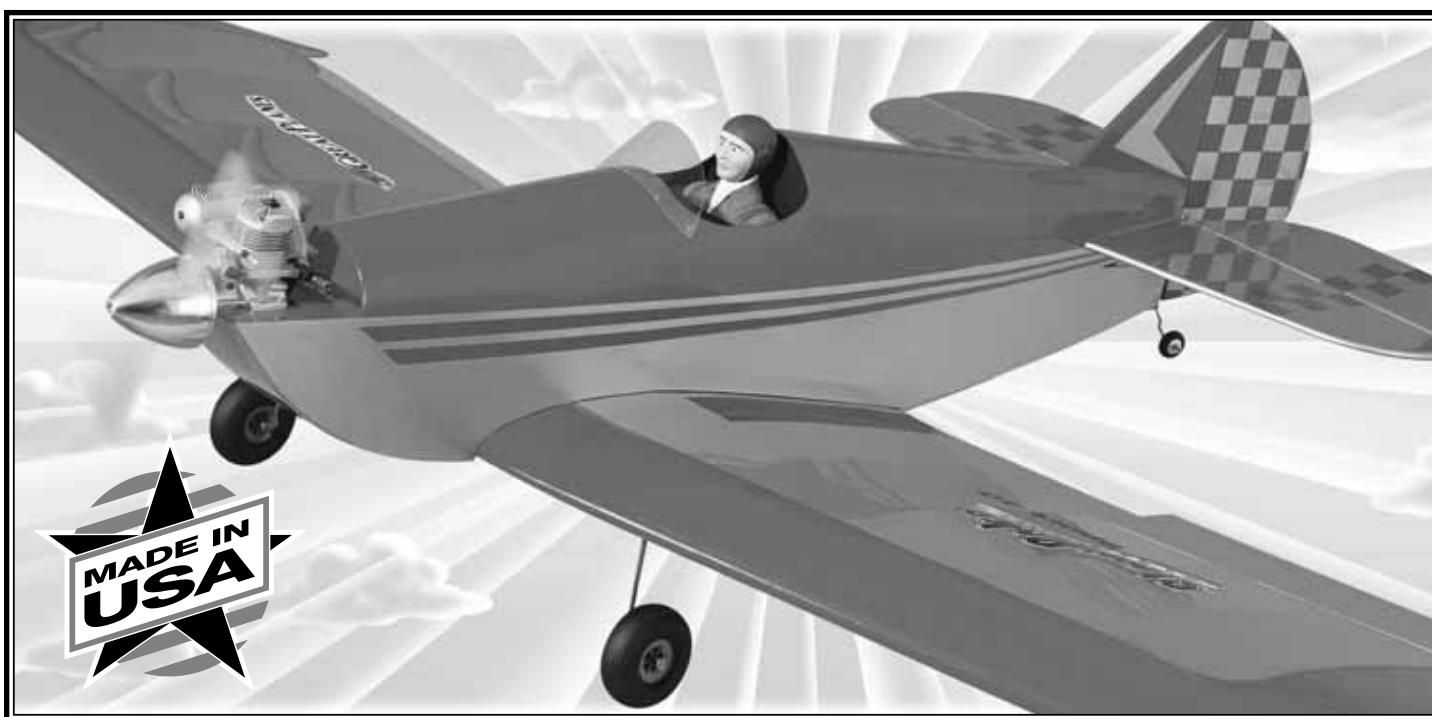

WARRANTY

Great Planes Model Manufacturing Co. guarantees this kit to be free from defects in both material and workmanship at the date of purchase. This warranty does not cover any component parts damaged by use or modification. **In no case shall Great Planes' liability exceed the original cost of the purchased kit.** Further, Great Planes reserves the right to change or modify this warranty without notice.

In that Great Planes has no control over the final assembly or material used for final assembly, no liability shall be assumed nor accepted for any damage resulting from the use by the user of the final user-assembled product. By the act of using the user-assembled product, the user accepts all resulting liability.

If the buyers are not prepared to accept the liability associated with the use of this product, they are advised to return this kit immediately in new and unused condition to the place of purchase.

READ THROUGH THIS INSTRUCTION MANUAL FIRST. IT CONTAINS IMPORTANT INSTRUCTIONS AND WARNINGS CONCERNING THE ASSEMBLY AND USE OF THIS MODEL.



P.O. Box 788 Urbana, IL 61801 (217) 398-8970
productsupport@greatplanes.com

TABLE OF CONTENTS

PROTECT YOUR MODEL, YOURSELF & OTHERS...FOLLOW THESE IMPORTANT SAFETY PRECAUTIONS

PRECAUTIONS	2
INTRODUCTION	3
DECISIONS YOU MUST MAKE	3
Engine selection.....	3
REQUIRED ITEMS	3
Suggested supplies & tools	3
DIE-CUT PATTERNS	4
Two-view	5
Common abbreviations	6
Types of wood.....	6
Metric conversions	6
Get ready to build	6
BUILD THE TAIL SURFACES	7
Build the fin & rudder	7
Build the stabilizer and elevators	8
BUILD THE WING	9
Build the center panel	9
Build the outer panels	11
Join the wing panels	15
BUILD THE FUSELAGE	16
Build the lower fuselage.....	16
Install the tail gear.....	20
Fit the wing & stab	20
FINISHING	21
Final sanding.....	21
Fuelproofing	21
Balance the airplane laterally.....	21
Cover the model.....	22
Recommended covering sequence	22
FINAL HOOKUPS AND CHECKS	23
Install the tank and throttle pushrod	23
Install the control surfaces	23
Install the landing gear.....	24
Radio installation.....	24
Control surface throws	25
Balance your model	26
PREFLIGHT	26
Charge the batteries	26
Find a safe place to fly.....	26
Ground check the model.....	26
Range check your radio	26
Engine safety precautions.....	27
AMA Safety Code	27
FLYING	27
Balance the propeller	Back Cover
Takeoff	Back Cover
Flight.....	Back Cover
Landing.....	Back Cover

Your SlowPoke Sport 40 is not a toy, but rather a sophisticated, working model that functions very much like an actual airplane. Because of its realistic performance, the SlowPoke Sport 40, if not assembled and operated correctly, could possibly cause injury to yourself or spectators and damage property.

To make your R/C modeling experience totally enjoyable, we recommend that you get experienced, knowledgeable help with assembly and during your first flights. You'll learn faster and avoid risking your model before you're truly ready to solo. Your local hobby shop has information about flying clubs in your area whose membership includes qualified instructors. You can also contact the national Academy of Model Aeronautics (AMA), which has more than 2,500 chartered clubs across the country. Through any one of them, instructor training programs and insured newcomer training are available.

Contact the AMA at their address or toll-free phone number.

Academy of Model Aeronautics

5151 East Memorial Drive
Muncie, IN 47302
(800) 435-9262
www.modelaircraft.org

1. Build the plane according to the plan and instructions. Do not alter or modify the model, as doing so may result in an unsafe or unflyable model. In a few cases the plan and instructions may differ slightly from the photos. In those instances the plan and written instructions are correct.
2. Take time to build straight, true and strong.
3. Use an R/C radio system that is in first-class condition, and a correctly sized engine and components (fuel tank, wheels, etc.) throughout your building process.
4. You must properly install all components so that the model operates properly on the ground and in the air.
5. You must check the operation of the model before **every** flight to ensure that all equipment is operating and that the model has remained structurally sound. Be sure to check nylon clevises or other connectors often and replace them if they show signs of wear or fatigue.

NOTE: We, as the kit manufacturer, provide you with a top quality kit and great instructions, but ultimately the quality of your finished model depends on how **you** build it; therefore, we cannot in any way guarantee the performance of your completed model, and no representations are expressed or implied as to the performance or safety of your completed model.

Remember: Take your time and follow directions to end up with a well-built model that is straight and true.

Please inspect all parts carefully before starting to build! If any parts are missing, broken or defective, or if you have any questions about building or flying this airplane, please call us at:

(217) 398-8970

or e-mail us at:

productsupport@greatplanes.com.

If you are calling for replacement parts, please reference the part numbers and the kit identification number (stamped on the end of the carton) and have them ready when calling.

INTRODUCTION

Thank you for purchasing the Great Planes SlowPoke Sport 40 for your next project. We are sure that you will find a great deal of modeling satisfaction while building and flying this larger, sport version of the legendary Slow Poke.

Since its introduction, the original SlowPoke has been successfully built and flown by modelers all over the world. Now, the SlowPoke Sport 40 builds upon this tradition but adds the dimension of larger size and ailerons for aerobatic enjoyment.

The SlowPoke Sport 40 incorporates several improvements, such as a redesigned wing for proportionately greater area and faster assembly and independent servo controlled barn door ailerons for simple installation and precise operation. The SlowPoke also has a redesigned fuselage for optimum placement of radio components for better balance and fewer blocks for less carving. The end result is an excellent sport model that can be flown as fun-fly stunter or as a docile Sunday flyer that will land at walking speed or fly backwards in a breeze. So now that you know how we have made a good plane better, dust off your work bench, put a new blade in your hobby knife and let's build a SlowPoke Sport 40!

DECISIONS YOU MUST MAKE

Engine selection

There are several engines that will work well in the SlowPoke Sport 40 but for economy and excellent performance we recommend a 2-stroke such as an O.S.[®] .40LA or SuperTigre[®] GS-40. In the 4-stroke category, an O. S. .48 or .52 Surpass[™] are two engines well suited to this model. Your choice of 2-stroke or 4-stroke engine will determine the location of the throttle servo and pushrod exit.

REQUIRED ITEMS

- 4 Channel radio with 5 servos
- Engine .32 - .46 2-stroke .48 - .52 4-stroke
- Propeller (Top Flite[®] Power Point[®])
- 10 oz. Fuel tank (Great Planes #GPMQ4104)
- 12" Medium fuel tubing (Great Planes #GPMQ4131)
- (2) 3" Main wheels (Great Planes #GPMQ4225)
- (1) 1" Tail wheel (Great Planes #GPMQ4241)
- (4) 5/32" Wheel collars (Great Planes #GPMQ4306)
- (2) 3/32" Wheel collars (Great Planes #GPMQ4302)
- 2-1/2" Spinner (Great Planes #GPMQ4520)
- (3) Rolls covering film (Top Flite MonoKote[®])
- 1/5 Scale pilot figure (*optional* - Williams Bros)
- 1/2" Latex Foam Rubber (Hobbico # HCAQ1050)

Suggested Supplies & Tools

*We recommended **Great Planes Pro[™] CA and Epoxy.***

- 2 oz. CA (Thin) (GPMR6003)
- 2 oz. CA+(Medium) (GPMR6009)
- 1 oz. CA- (Thick) (GPMR6014)
- CA Applicator Tips (HCAR3780)
- 6-Minute Pro Epoxy (GPMR6045)
- 30-Minute Pro Epoxy (GPMR6047)
- 2 oz. Aliphatic Pro Wood Glue (GPMR6160)
- Hand or electric drill
- Drill bits: 1/16", 5/64", 3/32", 1/8", 5/32", 3/16", 1/4", 17/32"
- Sealing iron (Top Flite)
- Heat gun (Top Flite)
- Hobby saw (X-acto Razor Saw)
- Hobby knife (HCAR0105)
- #11 Knife blades
- Razor plane (Master Airscrew[®])(MASR1510)
- Pliers
- Screw drivers (Phillips and flat tip)
- 1-1/4" T-Pins (HCAR5150)
- Straightedge with scale (HCAR0475)
- Masking tape
- Sandpaper (coarse, medium, fine grit)
- Sanding block
- Wax paper or Plan Protector (GPMR6167)
- Lightweight Balsa Filler such as Hobbico[®] HobbyLite[™] (HCAR3401)
- 1/4-20 Tap and tap wrench (GPMR8105)
- Isopropyl rubbing alcohol (70%)

DIE CUT PLY PATTERNS

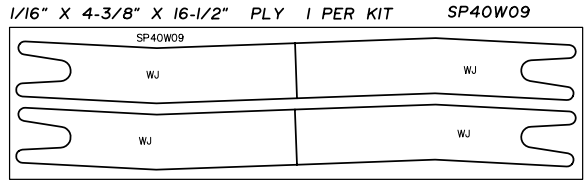
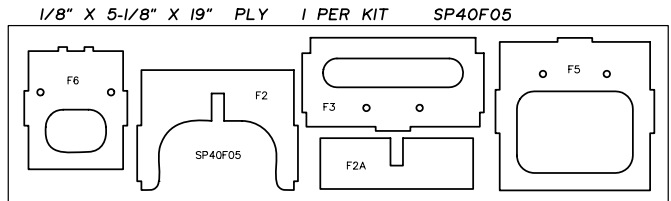
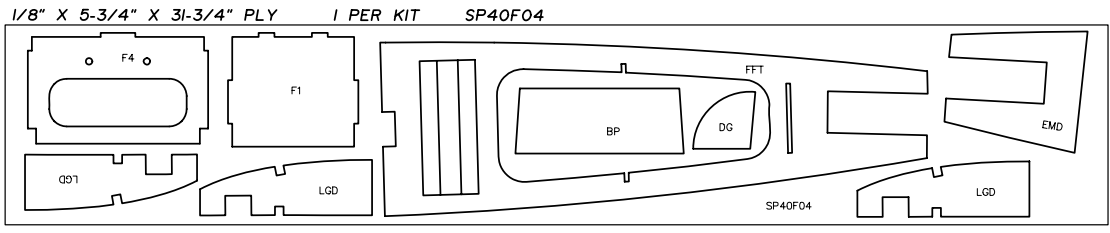
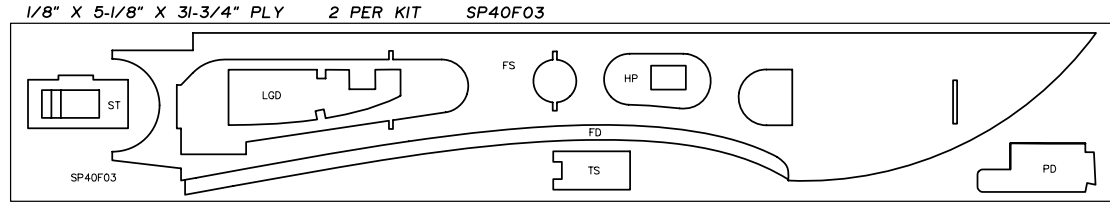
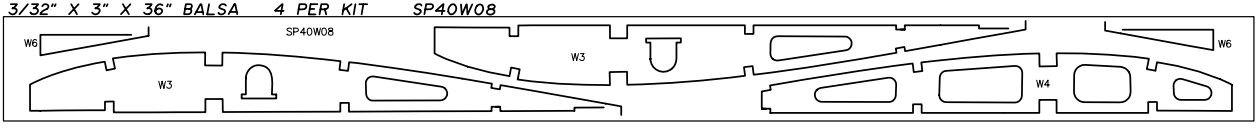
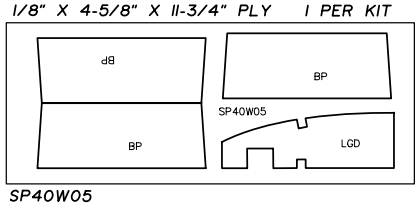
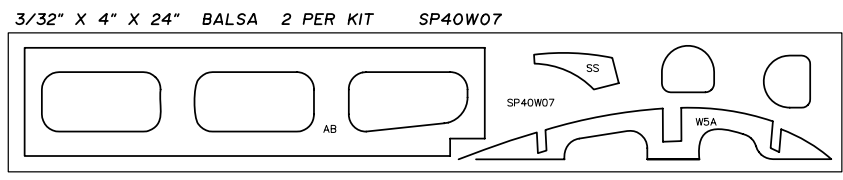
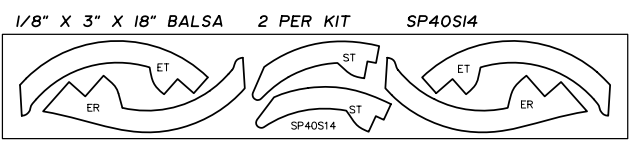
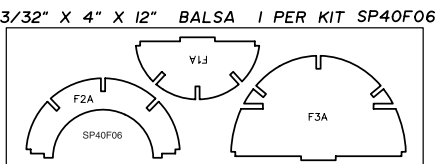
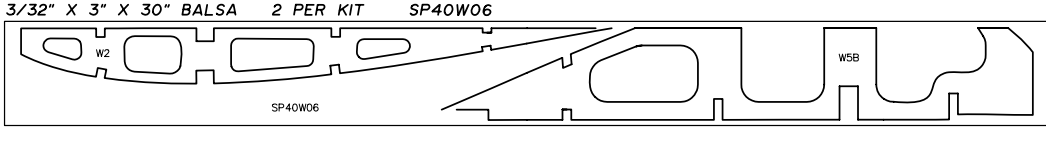
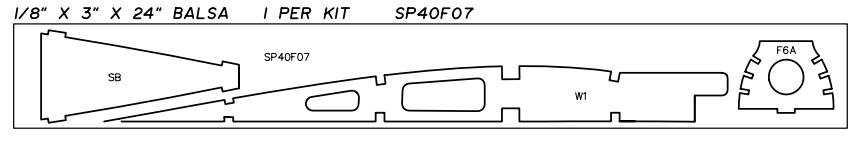
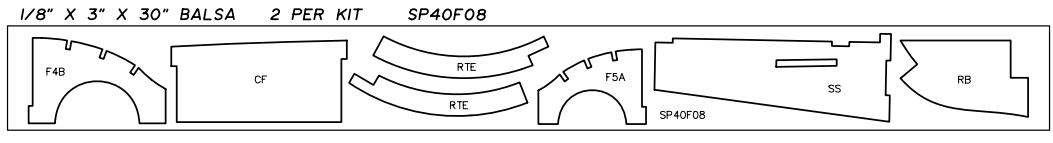
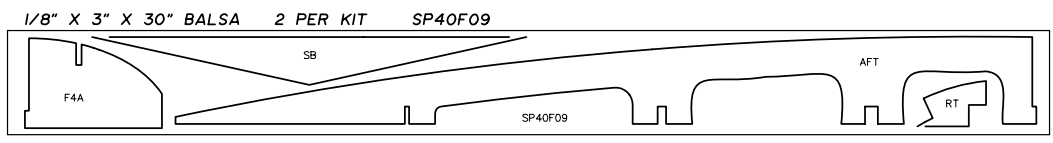

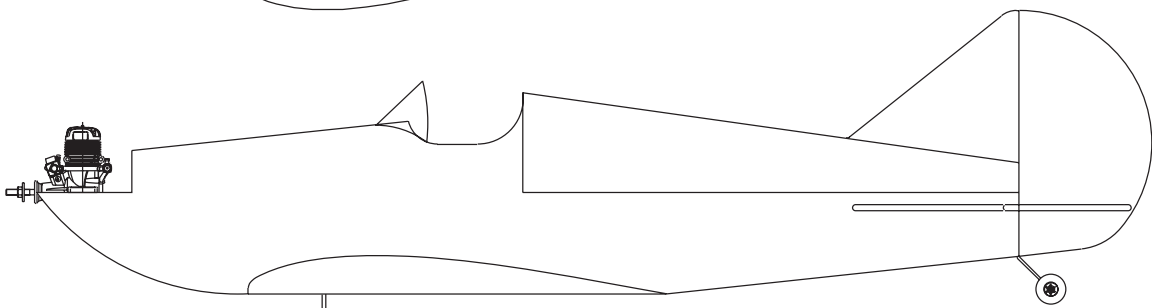
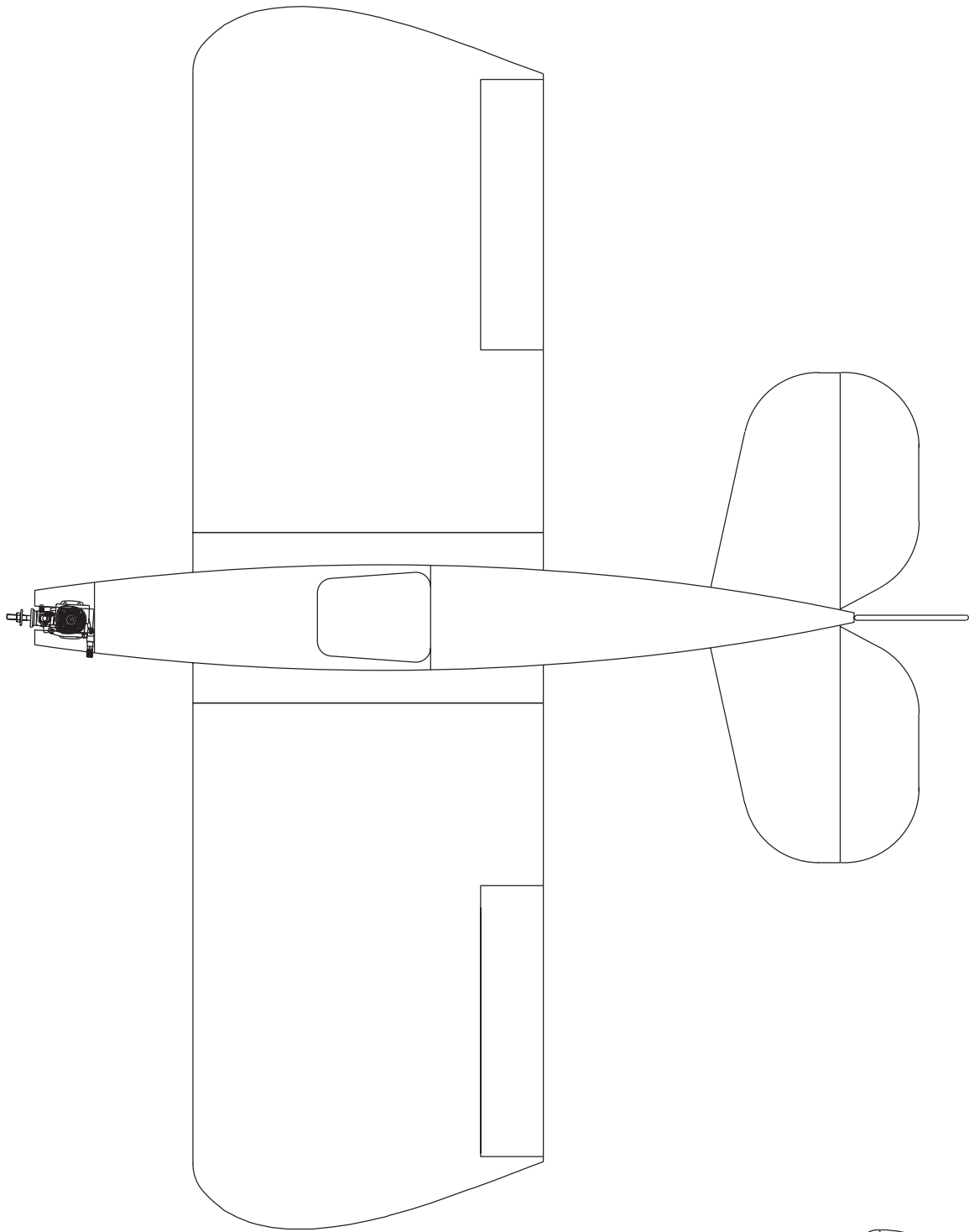

Use this drawing or photocopy it
and use the copy to design your
trim scheme.

EXPERT TIP
EXPERT TIP

On our workbench, we have three 11" **Great Planes Easy-Touch™ Bar Sanders**, equipped with #80, #150 and #220-grit sandpaper. This setup is all that is required for almost any sanding task. We also keep some #320-grit wet-or-dry sandpaper handy for finish sanding before covering.



Great Planes **Easy-Touch Bar Sanders** are made from lightweight extruded aluminum and can be found at most hobby shops. They are available in five sizes:

5-1/2" (GPMR6169) for those tight, hard-to-reach spots; 11" (GPMR6170) for most general purpose sanding; 22" (GPMR6172), 33" (GPMR6174) and 44" (GPMR6176) for long surfaces such as wing leading edges. The **Easy-Touch Adhesive-Backed Sandpaper** comes in 2" x 12' rolls of 80-grit (GPMR6180), 150-grit (GPMR6183) and 220-grit (GPMR6185) and an assortment of 5-1/2" long strips (GPMR6189) for the short bar sander. The adhesive-backed sandpaper is easy to apply and remove from your sanding bar when it's time for replacement.

Common Abbreviations

- | | |
|---------------------------|-------------------|
| Elev = Elevator | Fuse = Fuselage |
| LE = Leading Edge (front) | LG = Landing Gear |
| Lt = Left | Ply = Plywood |
| Rt = Right | Stab = Stabilizer |
| TE = Trailing Edge (rear) | " = Inches |

Types of Wood

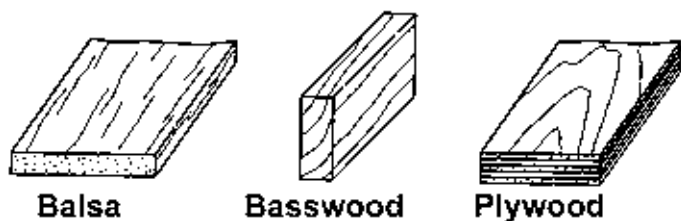

Metric Conversions

- 1" = 25.4mm (conversion factor)
- | | |
|---------------|---------------|
| 1/64" = .4mm | 1" = 25.4mm |
| 1/32" = .8mm | 2" = 50.8mm |
| 1/16" = 1.6mm | 3" = 76.2mm |
| 3/32" = 2.4mm | 6" = 152.4mm |
| 1/8" = 3.2mm | 12" = 304.8mm |
| 5/32" = 4mm | 15" = 381mm |
| 3/16" = 4.8mm | 18" = 457.2mm |
| 1/4" = 6.4mm | 21" = 533.4mm |
| 3/8" = 9.5mm | 24" = 609.6mm |
| 1/2" = 12.7mm | 30" = 762mm |
| 5/8" = 15.9mm | 36" = 914.4mm |
| 3/4" = 19mm | |

Get Ready to Build

1. Unroll the plan sheets. Reroll the plan sheets inside out to make them lie flat.
2. Remove all parts from the box. As you do, figure out the name of each part by comparing it with the plan and the parts list included with this kit. Using a felt tip or ball point pen, lightly write the part **name** or **size** on each piece to avoid confusion later. Use the die-cut patterns shown on pages 4 and 5 to identify the die-cut parts and mark them **before** removing them from the sheet. If any of the die-cut parts are difficult to punch out, do not force them! Instead, cut around the parts with a hobby knife. After punching out the die-cut parts, use your Easy-Touch Sander or sanding block to **lightly** dress the edges and to remove any die-cutting irregularities.
3. When cutting sticks, **always cut the longest pieces first** to avoid having to splice any pieces. Use the shorter pieces to make cross bracing and filler parts. **Save all leftover materials.** There are places where these short bits may come in handy.
4. As you identify and mark the parts, separate them into groups, such as **fuse** (fuselage), **wing**, **fin**, **rudder** and **stab** (stabilizer).

EXPERT TIP
EXPERT TIP

Zipper top food storage bags are handy to store your parts as you sort, identify and separate them into sub-assemblies.

BUILD THE TAIL SURFACES

Build the Fin & Rudder

Work on a flat surface over the plan covered with wax paper or Great Planes Plan Protector. Refer to the plan and die-cut patterns on pages 4 and 5 to identify and position the parts.

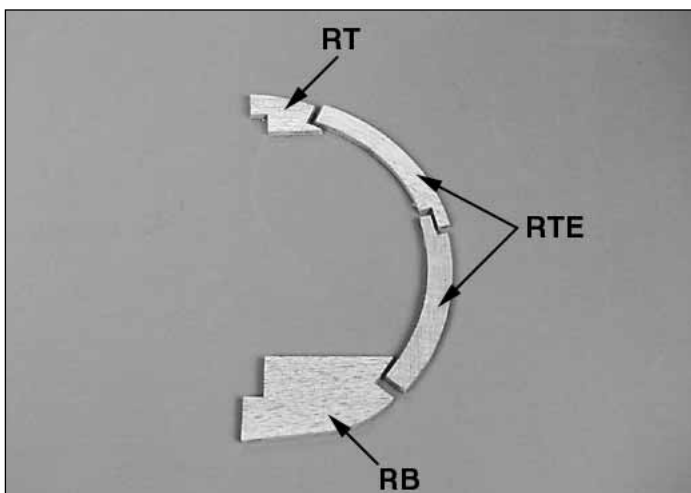

□ 1. Locate two each of the 1/8" die-cut balsa **rudder top (RT)**, the **two piece rudder trailing edge (RTE)** and the **rudder base (RB)** and glue each of the pairs together, carefully aligning the pieces for a flush fit. Sand off any irregularities or excess glue.

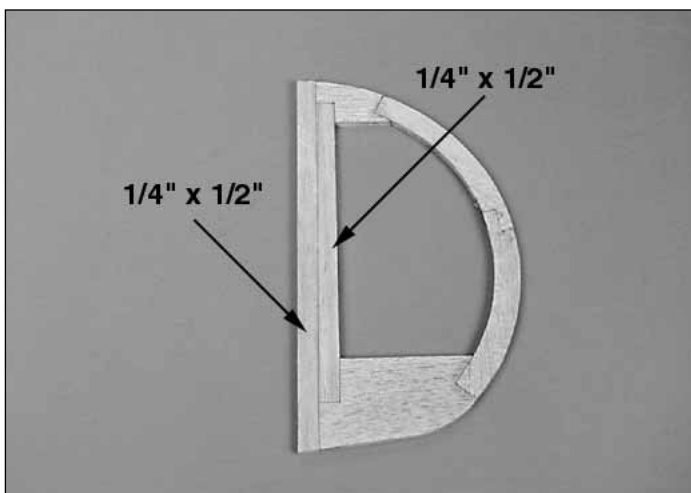

□ 2. Using a 1/4" x 1/2" x 30" balsa stick, measure and cut the two **rudder leading edge** sticks to match the plan. Glue these two pieces together over the plan and pin them in place. Test fit, then glue the **RT, RTE** and **RB** in position. Be sure that all parts are aligned over the plan.

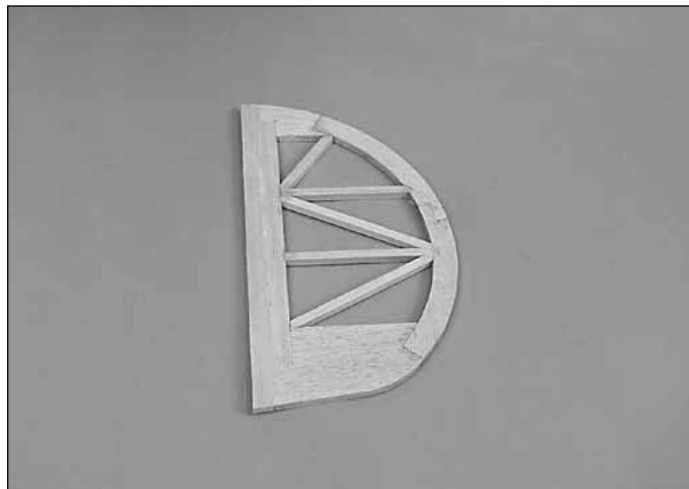

□ 3. Using a 1/4" x 1/4" x 24" balsa stick, measure, cut and glue all **cross bracing** for the rudder in position. Remove the pins and sand both sides of the rudder smooth.

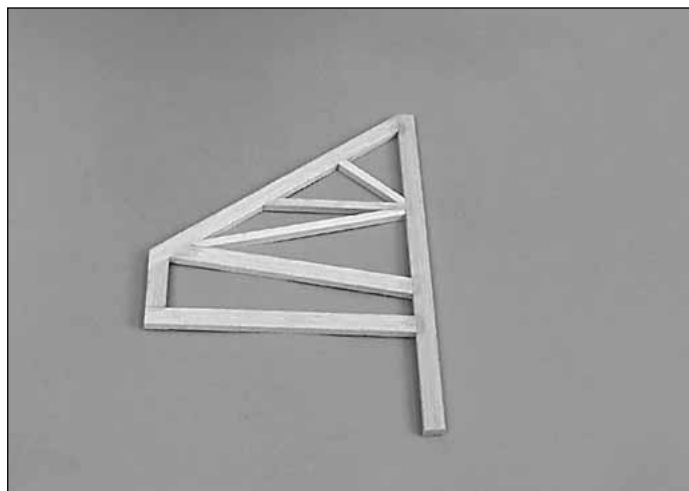

□ 4. Measure and cut the leftover 1/4" x 1/2" balsa stick from the rudder to start framing the fin to match the plan. Use additional 1/4" x 1/2" x 30" balsa as required. When satisfied with the fit, glue the pieces together and pin them to the board. Using a 1/4" x 1/4" x 24" balsa stick, measure, cut and glue all **cross bracing** for the fin in position. Remove the pins and sand both sides of the fin smooth.

□ 5. Draw a centerline on the leading edge of the rudder. Sand the leading edge of the rudder to a "V" shape as shown on the plan. Sand a radius on the leading edge of the fin and the trailing edge of the rudder.

Hint: A Great Planes Easy-Touch Multi Sander makes both of these sanding jobs a snap!

Build the Stabilizer & Elevators

Work on a flat surface over the plan covered with wax paper or Great Planes Plan Protector. Refer to the plan and die-cut patterns on pages 4 and 5 to identify the parts.

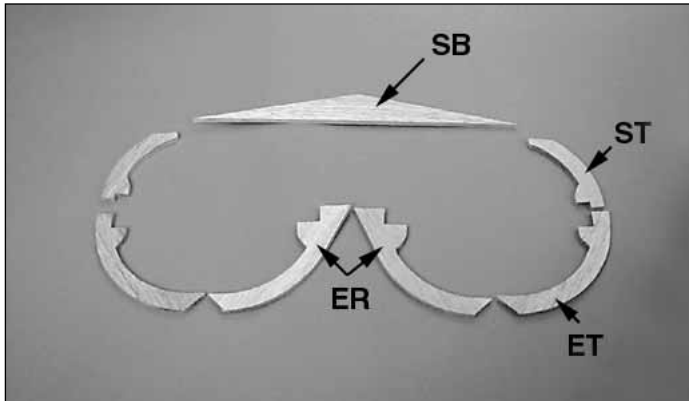

❑ 1. Locate two each of the 1/8" die-cut balsa **stab brace (SB)** and **four each** of the **stab tips (ST)**, **elevator tips (ET)** and **elevator roots (ER)**. Glue **two** pieces of each 1/8" part together to make 1/4" thick parts, carefully aligning the pieces for a flush fit. You will end up with one stab forward brace, two stab tips, two elevator tips and two elevator roots. Sand off any irregularities or excess glue.

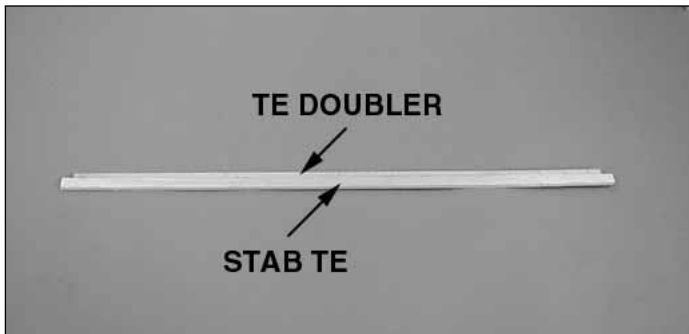

❑ 2. From a 1/4" x 1/2" x 30" balsa stick, measure and cut a piece 24-3/8" long to make the **stab trailing edge**. Pin it in position over the plan. From the 1/4" x 1/4" x 24" **basswood stick** cut and glue a 23-3/8" **TE doubler** to the forward edge of the balsa trailing edge.

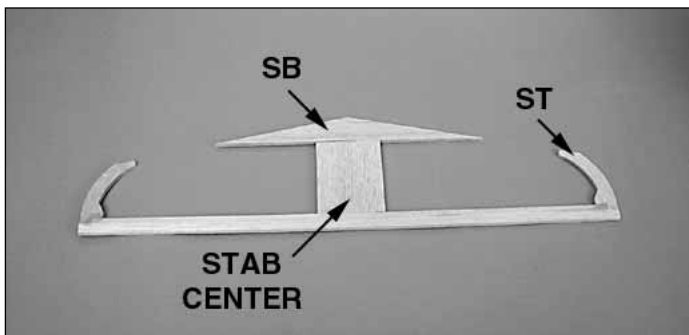

❑ 3. Position and glue the 1/4" x 3" x 3-15/16" balsa **stab center** and die-cut balsa **stab forward brace (SB)** in position over the plan. Position and glue the two stab tips (**ST**) to the trailing edge.

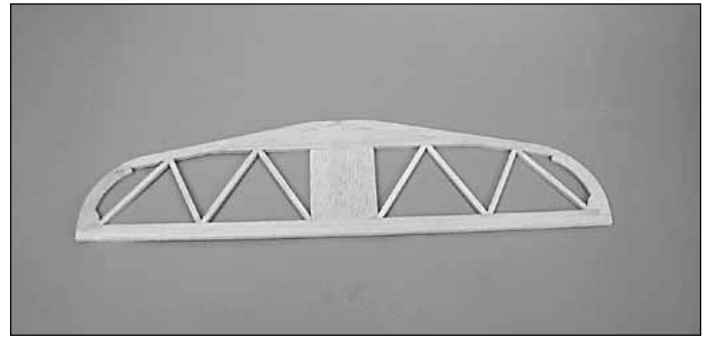

❑ 4. From 1/4" x 1/2" x 30" balsa measure, cut and glue the stab leading edges in position. From 1/4" x 1/4" x 24" balsa measure, cut and glue the cross bracing in position to complete the stab assembly. Remove the stab from the board and sand both sides smooth. Blend the leading edge at the tips to match the plan. Sand a flat on the front of the leading edge to match the plan. Leave the trailing edge square.



❑ 5. Pin the die-cut balsa elevator tip (**ET**) and elevator root (**ER**) in position over the plan. From a 1/4" x 5/8" x 30" stick, measure, cut and pin the elevator leading edge and trailing edge in position. When satisfied with the fit, glue the parts together.

❑ 6. From leftover 1/4" x 1/4" balsa, install the elevator cross bracing as shown on the plan. Remove the elevator from the board and sand both sides smooth.

❑ 7. Go to step 5 and build a second elevator to match the first. **Hint: Cover first elevator with wax paper or Plan Protector then build an identical one right on top of the first!**

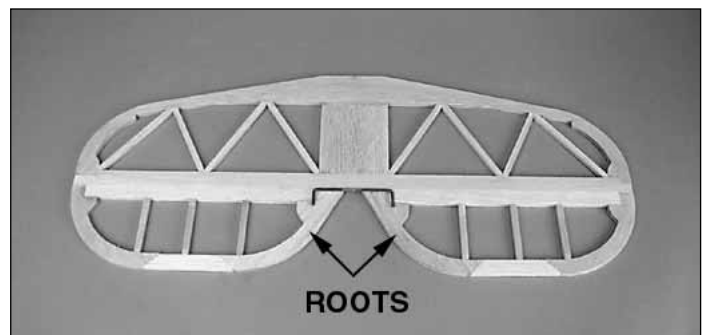

❑ 8. Pin the Stab to the board and then align both elevators along its trailing edge, flush at the tips. Be sure your elevators are positioned correctly with the "roots" to the center of the stab. Pin the elevators in position, then using the **elevator joiner wire** as a guide, accurately mark the location of the **torque arms**. Remove the elevators from the board.

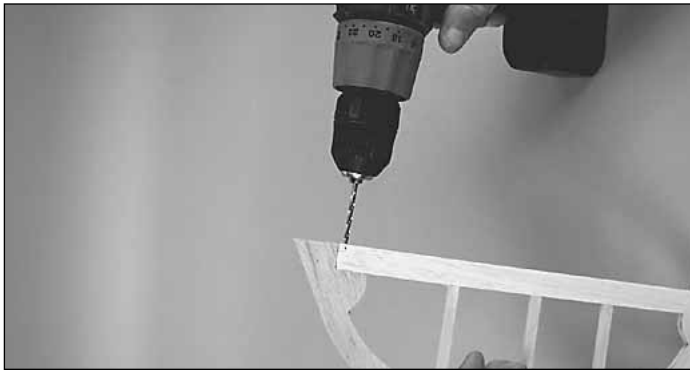

□ □ 9. Using your marks as a guide, carefully drill a 1/8" diameter hole into each elevator's leading edge, approximately 3/4" deep.

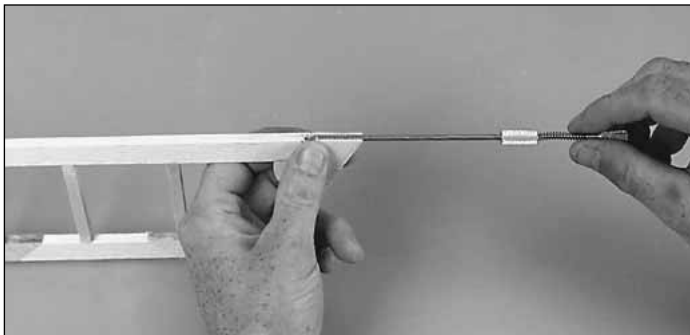

□ □ 10. Cut a 1/8" deep groove from the elevator root to the hole you just drilled. **Hint:** This can be easily done using a piece of sharpened 1/8" brass tubing or by using a Great Planes Groove Tube.

□ □ 11. Insert the elevator joiner wire into the elevators and check the combined parts for flatness and also that their leading edges are straight. Carefully bend the joiner wire as needed to obtain proper alignment. Check that the overall length of the elevators matches the length of the stab. Once satisfied with the alignment and fit, remove the joiner wire, noting which end goes where. Roughen both "torque arms" with coarse sandpaper or a file.

□ □ 12. Round off each elevator's trailing edge and the stab leading edge. Draw a centerline on their leading edges, then sand both to a "V" as shown on the plan.

□ □ 13. Pack the joiner wire hole in **only one elevator** with 6-minute epoxy, then insert the joiner wire completely. **Without using any epoxy on the other elevator**, slide it onto the joiner wire and once again check for alignment with a straightedge. Once the epoxy has cured, clean up the leading edge with medium sandpaper and set both elevators aside. **Note:** You will glue the other half of the joiner wire in position during final assembly, after the model is covered, so don't get ahead of yourself just yet.

Well that was pretty painless wasn't it? The tail feathers are done and now we can move on to the bigger stuff. Clean off your bench, cover the wing plan with wax paper or Plan Protector and let's get going on the center section of the wing.

BUILD THE WING

Build the Center Panel

NOTE: The wing panels are built "right-side up" over the plan.

Work on a flat surface over the plan covered with wax paper or Great Planes Plan Protector. Refer to the plan and die-cut patterns on pages 4 and 5 to identify and position the parts.

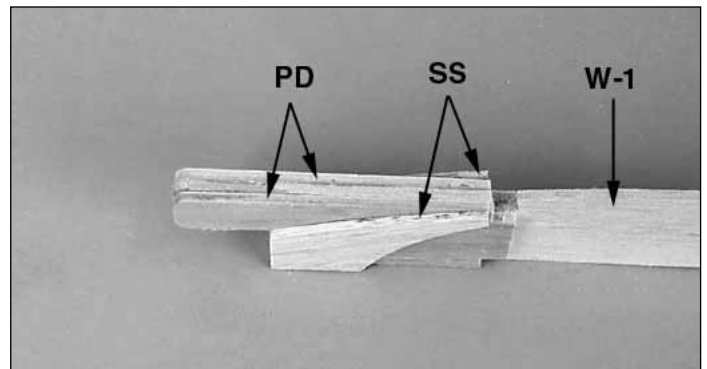

□ 1. Locate one 1/8" die-cut balsa **W-1** rib, two 1/8" die-cut ply **wing plug doublers (PD)** and two 3/32" die-cut balsa **sheeting supports (SS)**. Use medium CA to glue one wing plug doubler to each side of the W-1 rib, aligned with the forward end. Glue one 3/32" sheeting support to each side of the plug doublers, flush with the bottom edge and LE.

□ 2. Cut four 1/16" x 3" x 30" balsa sheets into twelve 8-5/8" long pieces. True up the edges. Refer to the *Expert Tip* that follows, then edge glue six pieces together to make the bottom skin and six to make the top skin. The skins will measure roughly 8-5/8" x 18". Trim one skin to 17-1/8". This will be used on the bottom of the center panel.



CA is much harder than balsa, so when you sand edge glued sheets you will usually end up with a ridge along the joint. To avoid this problem the Great Planes Model Shop team have reverted to using ordinary wood glue for this application. We prefer Wood Glue as it sets quickly, is water resistant and sands easily. We put a blob of the glue on a sheet of wax paper, then apply it to the edge of the wood with a finger-tip. After joining the sheets, wipe off any excess with a tissue, then use a couple of strips of masking tape to hold the sheets together while the glue sets. Sand the joint by using a sanding block and fresh 220-grit sandpaper. Work the block in a circular motion across the joint until smooth.

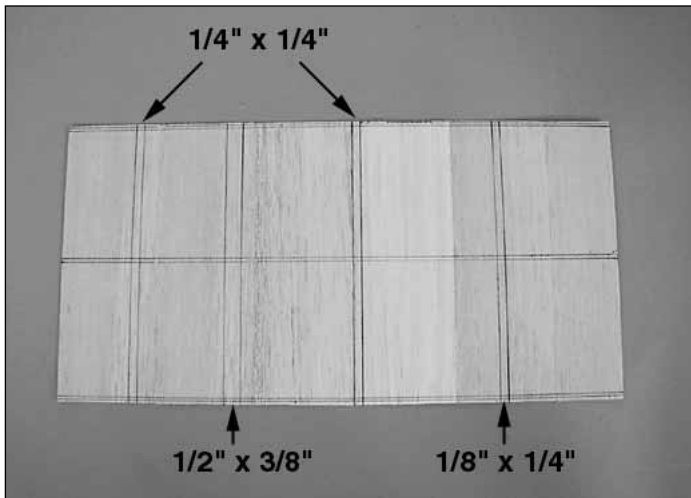

❑ 3. Pin the 17-1/8" skin over your protected plan. Use the tic marks on the plan to draw the location of the ribs and spar on the surface of the balsa skin.

❑ 4. Locate two 1/2" x 3/8" x 36" balsa **main spars**. Cut one 8-5/8" piece from **each** stick to use for the center section main spars. Cut four 1/4" x 1/4" x 8-5/8" auxiliary spars from two 24" sticks. Without using glue, pin the bottom 8-5/8" main spar onto the sheeting where marked. Lay the two 1/4" x 1/4" auxiliary spars in position.

❑ 5. From a 1/8" x 1/4" x 24" balsa stick cut two 8-5/8" aft auxiliary spars. Lay one of these in position.

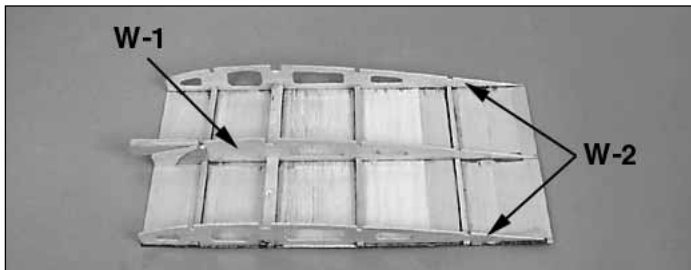

❑ 6. Without using glue, position the W-1 rib on the spars and along the W-1 reference line. The forward edge of the W-1 rib should be 1/16" **behind** the forward edge of the sheeting to allow for the sub-leading edge. Position the W-2 ribs over the spars and aligned on the marks you made. When everything is aligned, **wick thin CA** into all joints and under the spars. **Use a builders square or drafting triangle to be sure all ribs are vertical.**

❑ 7. Install all of the top spars and glue them in place while checking that the ribs remained vertical.

❑ 8. From two 1/16" x 3/4" x 36" balsa **sub leading edges** cut a piece 4-3/8" long from each. Glue this piece to the forward edges of the ribs (save the remaining pieces for the wing panels). Sand the top edge of this strip to match the contour of the airfoil on top of the wing.

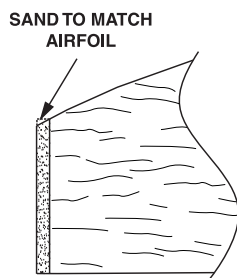

❑ 9. Use the 1/2" x 2-1/2" x 9" balsa block to make a filler between the W-1 and W-2 ribs at the aft edge of the panel to support the wing bolts. The block needs to be carved to match the ribs. The easiest way to shape the blocks is with a long blade hobby knife followed by a power sander. Perform the shaping **before** you glue the fillers in position.

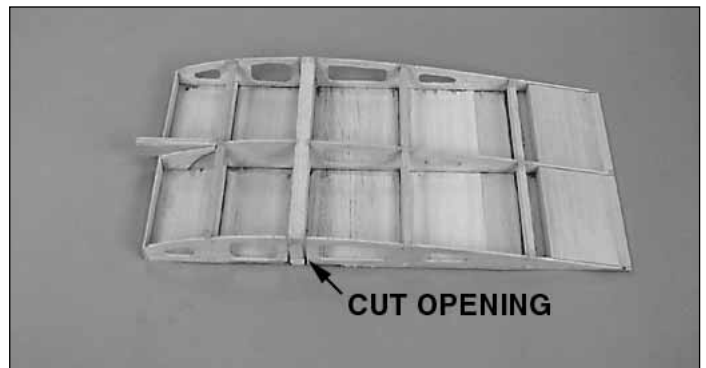

❑ 10. Sand everything flush with the outer edges of the W-2 rib. Measure and mark a line 1/16" on each side of the spar on the outer side of the W-2 ribs. Carefully cut away the balsa on the inside of those lines.

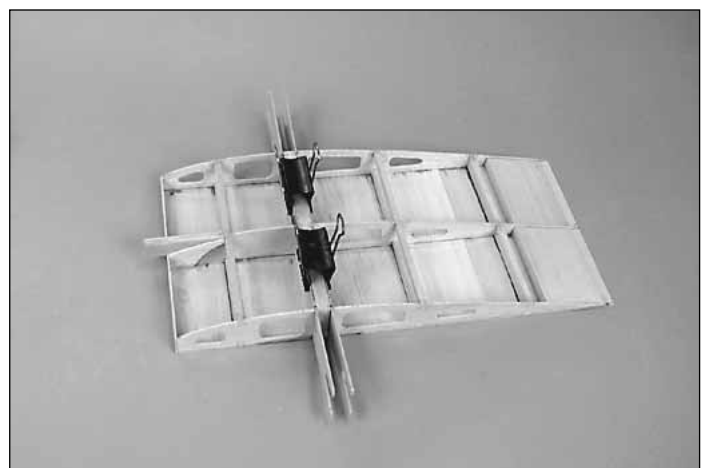

❑ 11. Test fit the wing joiners in position on both sides of the main spars. Be sure the joiners are flat on the bottom sheeting and that the square inboard ends are against W-1. When satisfied with the fit, use 30-minute epoxy to glue all four joiners to the spars on both sides of the wing panel.

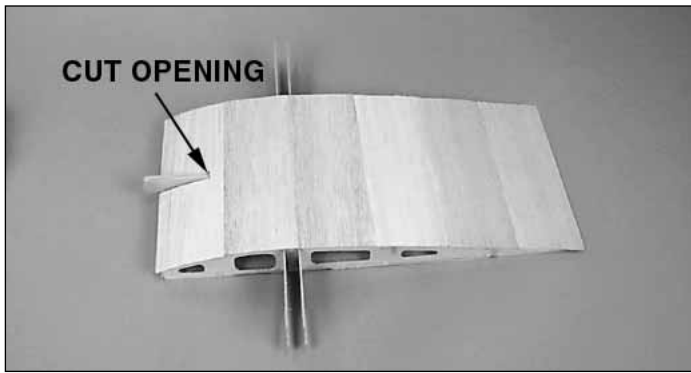

□ 12. After the epoxy has cured, measure and mark the location of the wing plug on the top skin sheeting (that you prepared in step 2). Cut an opening to allow the sheeting to fit around the wing plug. When satisfied with the fit, glue the skin in place.

Hint: We have found that using Aliphatic Resin (wood glue) works well for gluing *top* skins.

□ 13. Trim the sheeting to size and sand all edges smooth. Carefully cut two servo lead access holes in the top of the wing panel at the location shown on the plan.

□ 14. Cut **one** 4-3/8" length from **two** 3/8"x 7/8" x 30" balsa **LE sticks**. *The remaining 25-5/8" lengths will be used for the outer panel LE.* Glue both of these short pieces to the LE of the center panel, centered on the wing plug and flush with the bottom edge. With reference to the plan, shape the LE using a razor plane, hobby knife and sanding bar to blend it with the airfoil.

Build the Outer Panels

Work on a flat surface over the plan covered with wax paper or Great Planes Plan Protector. Refer to the die-cut patterns on pages 4 and 5 and the plan to identify and position the parts.

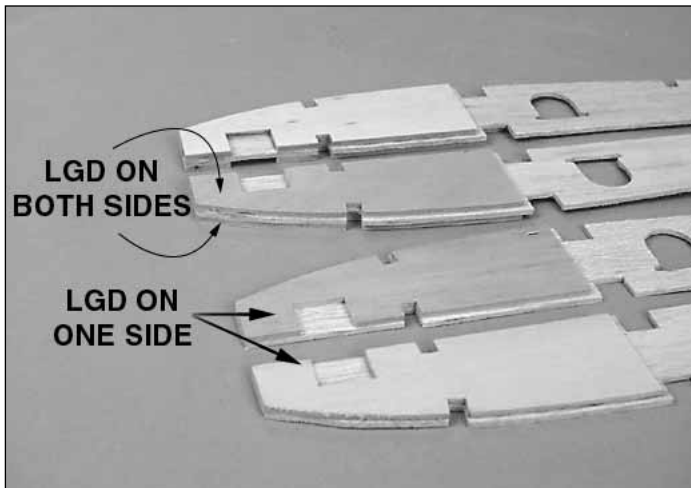

□ 1. Locate four 3/32" die-cut balsa **W-3** ribs and six 1/8" die-cut ply **W-3A** landing gear rail doublers (**LGD**). Using

thick CA, glue a doubler to both sides of only **two** ribs, making sure the auxiliary spar notches are aligned. Glue a doubler to the **left side** of one remaining rib and to the **right side** of the other rib, aligning them in the same manner.

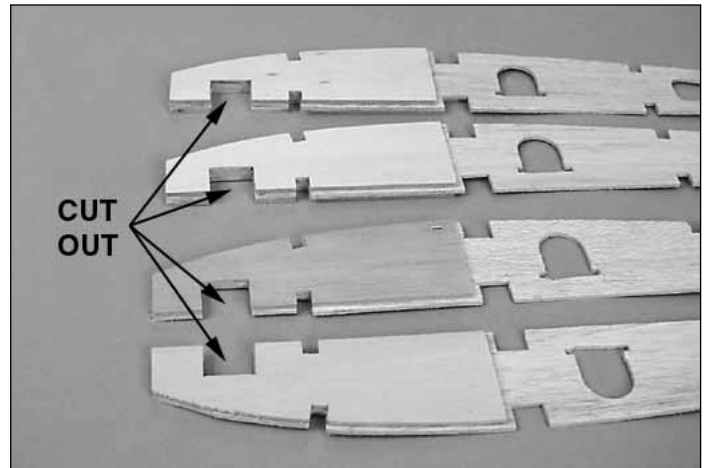

□ 2. Use a hobby saw to carefully cut away the balsa from the landing gear rail notch. Test fit a **landing gear rail** in position. It should be a snug fit. If necessary, the notch may be enlarged with a sanding block.



□ □ 3. Trim a sheet of 1/16" x 3" x 30" balsa to 2-1/2" x 23-1/2". Pin this sheet to the leading edge of the wing, aligned with the rear edge of the forward auxiliary spar and the root of the panel. The forward edge and tip end of the sheet will be slightly oversized to allow for trimming later. Glue a 1/4" x 1/4" x 24" balsa stick to the top of the sheet, flush with the rear edge and flush with the root end.

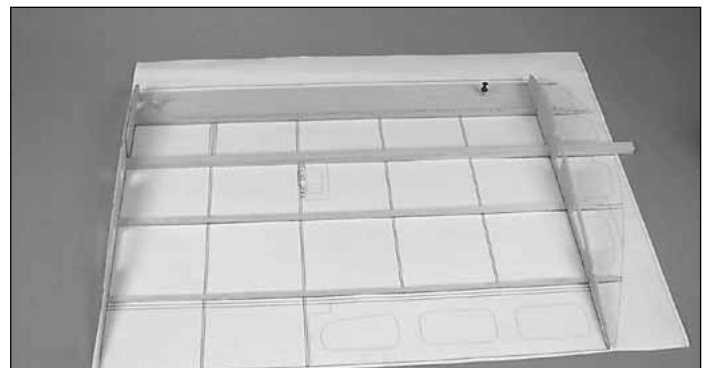

□ □ 4. Locate one 1/2" x 3/8" x 27" balsa **main spar** (left over from the center section assembly) and lay it in position

over the plan. Place a 1/4" x 1/4" x 24" auxiliary spar and a 1/8" x 1/4" x 24" rear spar in position as well. Without using any glue, position a W-3 rib (with the single doubler to the inside of the panel) onto the spars and LE sheeting. Add another W-3 rib (without any doublers) to the spars at the tip end of the panel.

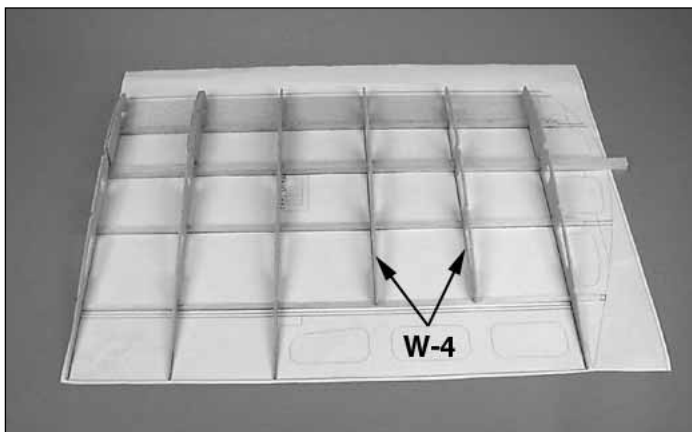

□ □ 5. Pin the two ribs and spars in position. Still without using glue, add the W-3 rib (with both doublers), two plain W-3 ribs and two W-4 ribs.

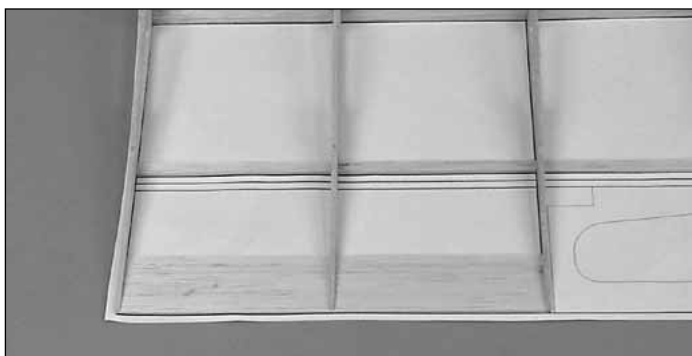

□ □ 6. From a 1/16" x 3" x 12" balsa sheet cut two 12" strips 1-3/8" wide. Save the second one for the other wing. Slide one of the strips under the trailing edge of the panel. The strip should butt against the forward edge of the notch in the W-3 ribs. Pin it in position. Trim the outboard end flush with W-3. Pin the cut off piece under the outboard W-3.

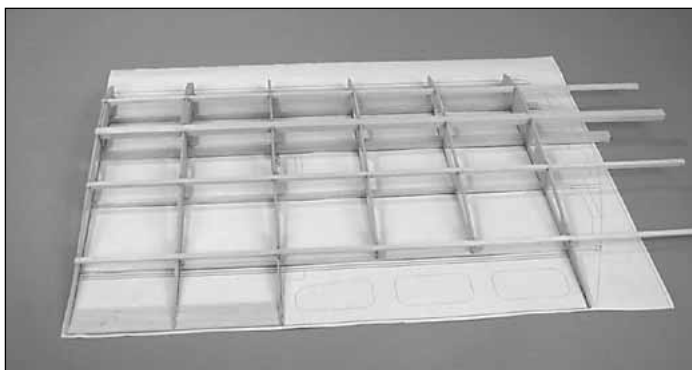

□ □ 7. Still without using any glue, install the 1/4" x 1/4" x 30" top auxiliary spars, 1/2" x 3/8" x 36" main spar and 1/8" x 1/4" x 30" aft spar. **Do not trim the spars at the tip end!** Allow them to protrude past the last rib.

□ □ 8. Starting with the W-3 rib with **two doublers (not the root rib)**, glue all ribs (except the root rib) in position with thin CA. Work toward the tip, checking that each rib is vertical with a builders square or triangle.

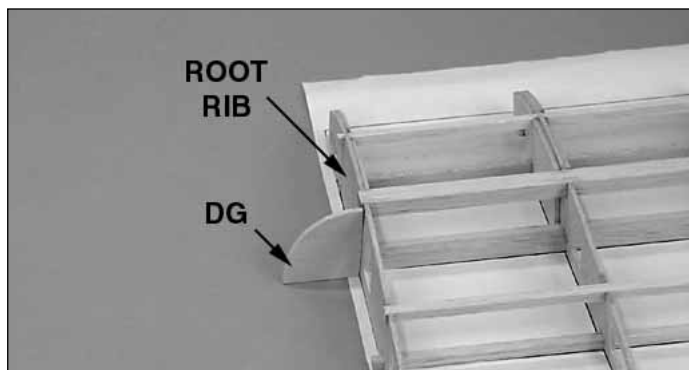

□ □ 9. Position the 1/8" die-cut ply **dihedral gauge (DG)** against the **inboard face of the root rib** and angle the rib to match the angle of the gauge. Check that the rib is straight (chordwise) with a straightedge. Once satisfied that the angle is correct along the length of the rib, glue it in place with thin CA. Check your work to be sure everything is properly glued.

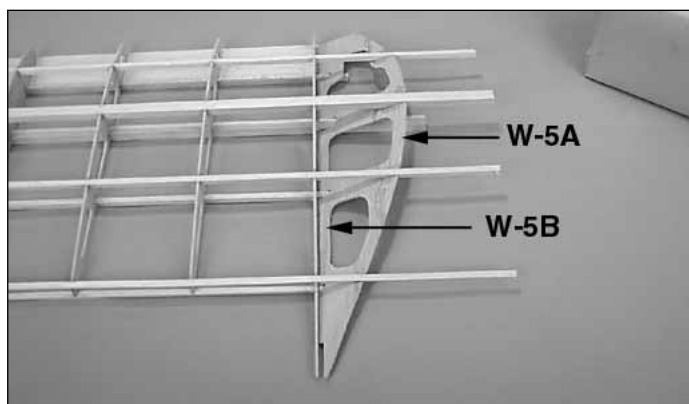

□ □ 10. Glue the two pieces of the 3/32" die-cut balsa **wing tip (W5A AND W5B)** together and sand the joint smooth. Slide the tip over the spars and tilt it up to fit against the top spars. When satisfied with the fit, glue the tip in place. All of the spars may now be roughly trimmed to size; sanding will be done later.

SAND TO MATCH
AIRFOIL

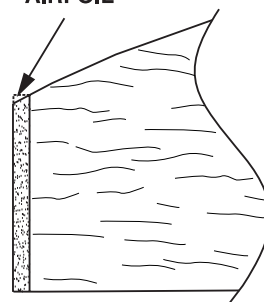

□ □ 11. From 1/16" x 3/4" balsa **sub leading edge** stock cut a 24-1/2" long piece. Glue this piece to the LE of all ribs. Sand the top edge of the sub leading edge to match the angle of the airfoil.

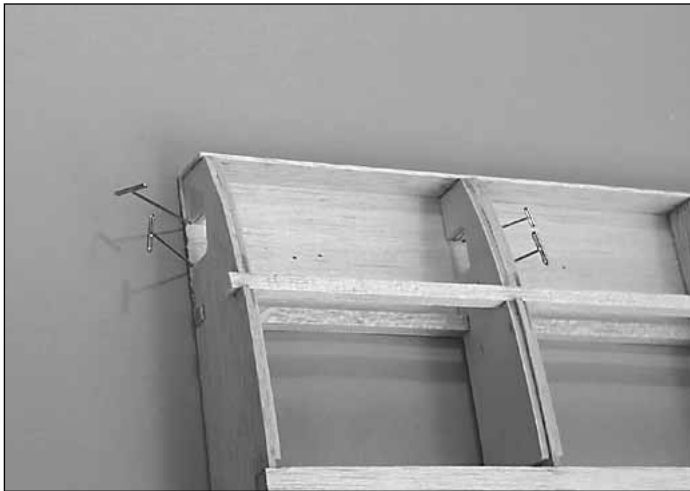

□ □ 12. Poke a T-pin through the bottom LE sheeting at the four corners of the landing gear rail notches so you will be able to locate them during the next step. Remove the panel from the board.

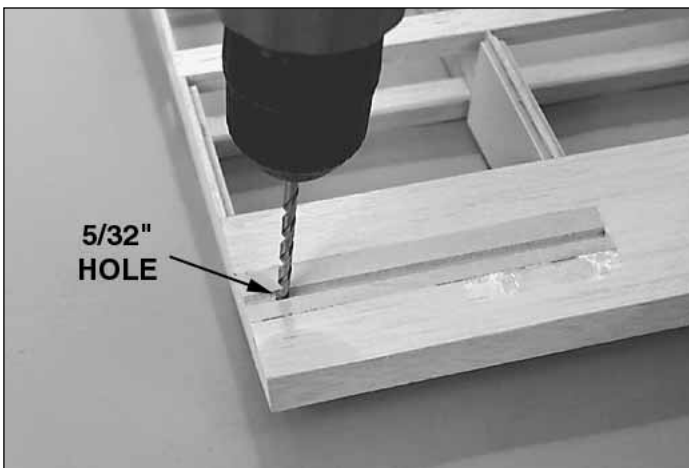
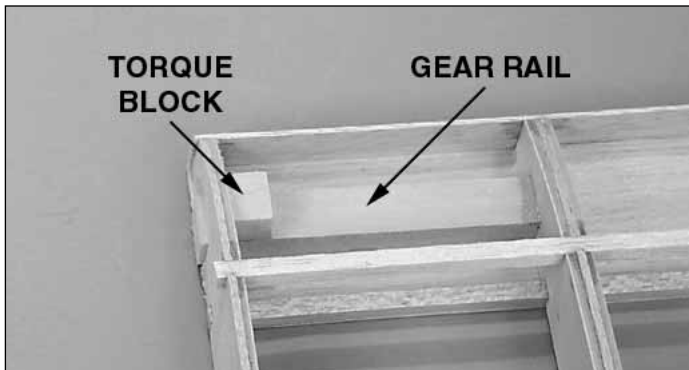

□ □ 13. Using the pin pricks for reference, mark and cut out the sheeting where the landing gear rail will fit. Use 6-minute epoxy to glue the landing gear rail and the $3/4" \times 9/16" \times 1/2"$ torque block in position to the inside of the W-3 rib with the single doubler. Clamp the torque block in position until the epoxy has cured. Drill a $5/32"$ hole through the landing gear rail and the torque block $1/2"$ from the inboard edge. Keep the drill bit vertical.

□ □ 14. Sand the protruding spars at the tip and root of the wing flush with their respective flat surfaces. Replace the panel on the board, pinning it in a few places to hold it flat.



□ □ 15. Use thick CA to glue a sheet of $1/16" \times 3" \times 30"$ balsa to the top leading edge of the wing panel from the root end, extending over the tip. The sheet should fit against the rear edge of the top auxiliary spar. Once the CA has cured, trim and sand the LE, root and tip sheeting flush with their respective surfaces.

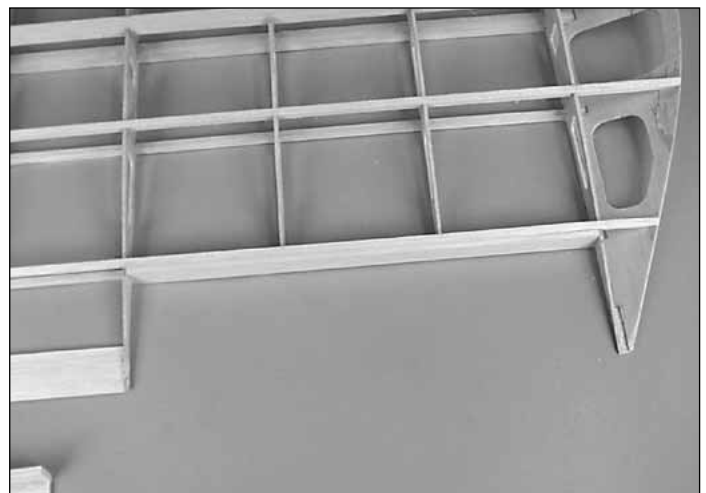

□ □ 16. From a $3/16" \times 1" \times 30"$ balsa stick, measure, cut and fit a TE spar for the aileron pocket. The cut piece will be approximately $13-3/8"$ long. Glue it to the two TE spars and W-3 ribs. Trim the $3/16"$ TE spar flush with the aft auxiliary spars. Using the leftover piece of the $3/16" \times 1"$ stick, cut a second piece that will be used as the aileron LE. This piece needs to be about $3/32"$ under size to allow for the aileron gap at each end.

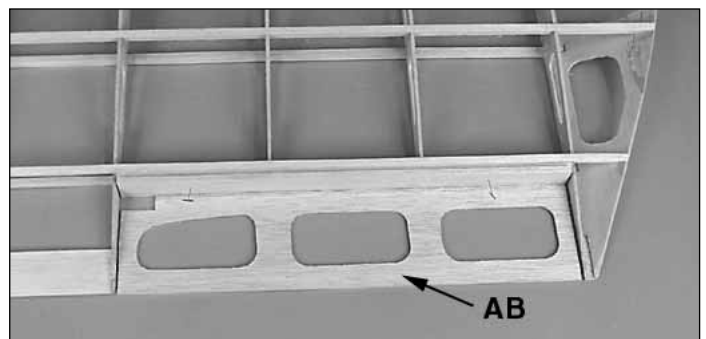

□ □ 17. Center the aileron LE in the aileron pocket and pin it to the TE of the wing panel. Center the $3/32"$ die-cut balsa aileron base (AB) between the W-3 ribs (with the horn cut-out toward the LE and root) and pin it flat on the board. Glue it to the LE.



□ □ 18. Glue the 3/32" die-cut balsa **aileron ribs (W6)** in position as shown on the plan. Try to avoid letting any parts stick to the wing panel. Remove the aileron from the board.

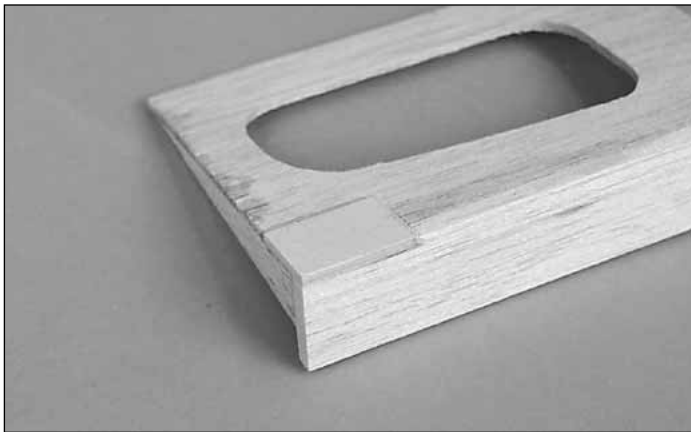

□ □ 19. Remove about 1/8" of the balsa aileron LE edge at the horn cut-out to allow the ply horn plate to be recessed into the aileron. Glue the 1/8" die-cut ply **horn plate (HP)** into the notch.

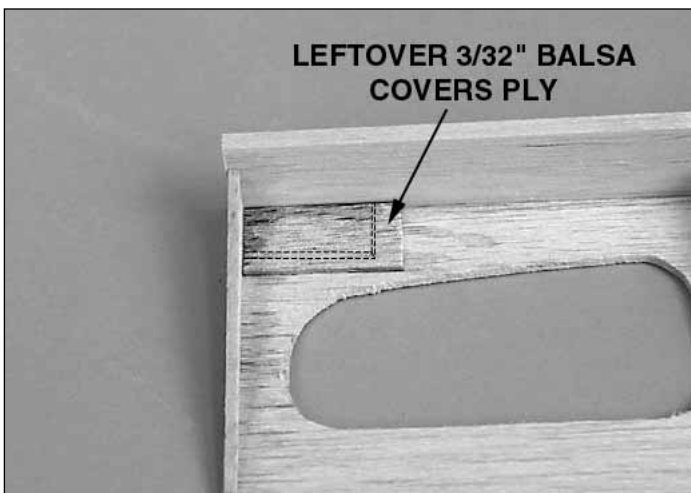

□ □ 20. Turn the aileron over and glue a piece of 3/32" x 3/4" x 1-1/2" leftover balsa over the top of the horn plate, being sure to cover the area as shown in the photo.

□ □ 21. Place the aileron back in position in the wing, flat on the board. Shape the top of the aileron LE to match the wing TE.

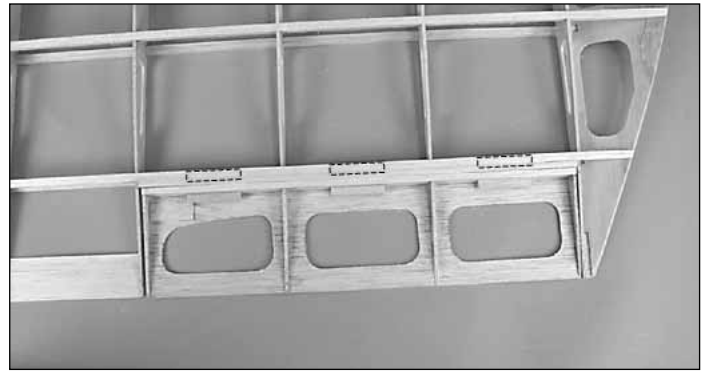

□ □ 22. Using the plan for reference, measure, cut and glue leftover pieces of 1/4" x 1/4" x 1-1/2" balsa stick to the inside of the wing TE and aileron LE to provide more surface area for the hinge slots. Be sure the sticks are centered vertically. Bevel and hinge the ailerons the same as you did the elevator and rudder.

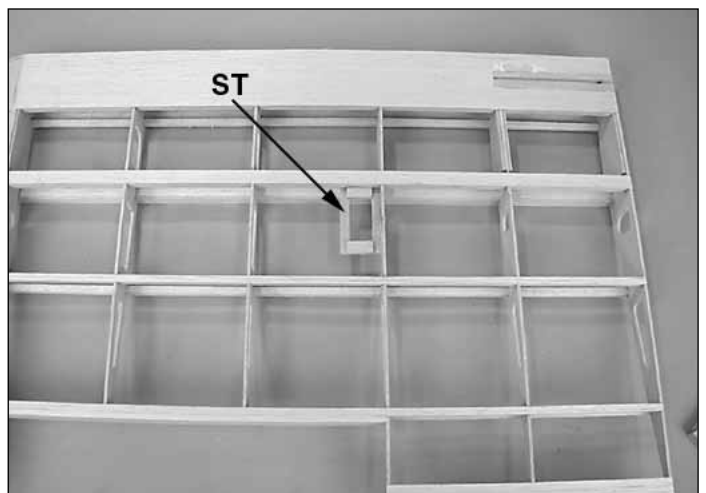
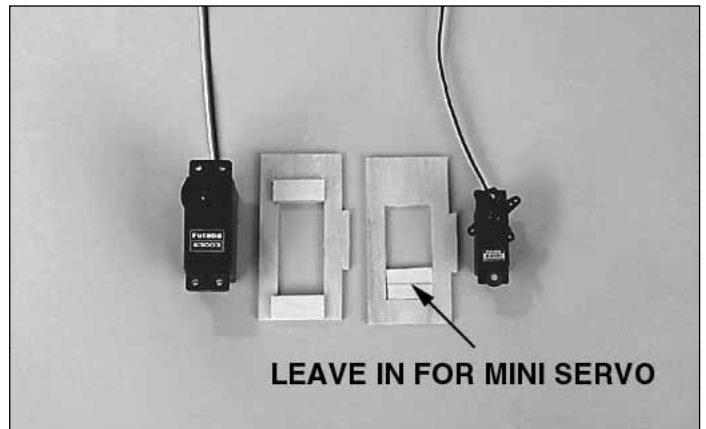

□ □ 23. Locate a 1/8" die-cut ply **aileron servo tray (ST)**. **IMPORTANT:** If you will be using **mini servos**, only punch out the forward section of the servo tray, then wick thin CA into the remaining seams. For standard servos, remove the three center pieces, then glue the two **servo doublers** to each end of the servo opening. The doublers must face toward the bottom of the wing. Glue the aileron servo tray into the notch in the W-3 rib and also to the spar. Apply a fillet of thick CA to the joint between the tray and the rib.

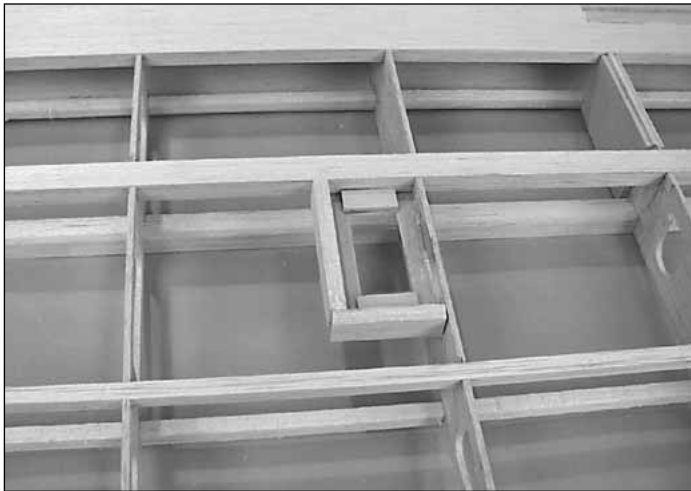

□ □ 24. Using 1/4" x 1/2" balsa left over from the tail, build a "covering pocket" around the servo.

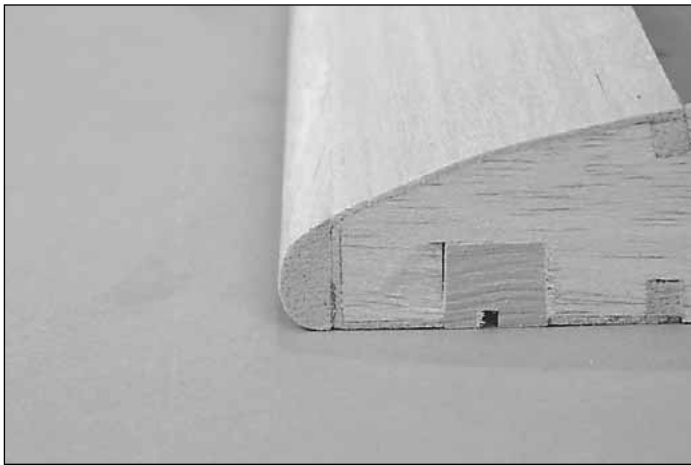

□ □ 25. Locate a 3/8" x 7/8" x 25-5/8" balsa **LE** stick left over from the center section assembly. Glue this stick to the sub leading edge, flush with the bottom edge and root end. With reference to the plan, shape the LE using a razor plane, hobby knife and sanding bar to blend it with the airfoil.

□ □ 26. From 3/32" x 3" x 36" balsa sheet, measure, cut and glue vertical grain shear webs to fit the two locations shown on the plan.

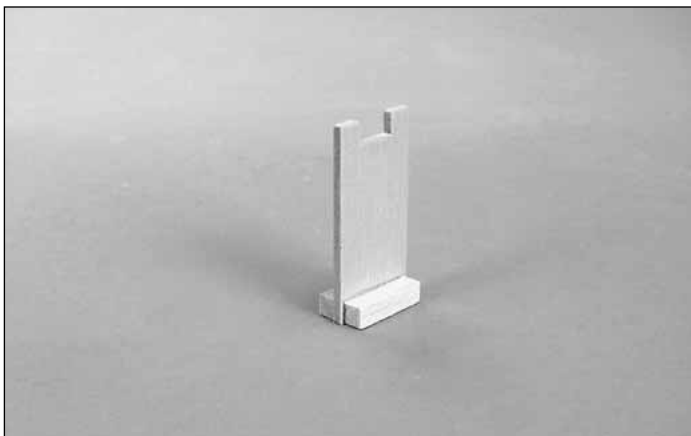

□ □ 27. Glue leftover 1/4" x 1/4" balsa to both sides of the 1/8" die-cut ply **wing tip supports (TS)**.

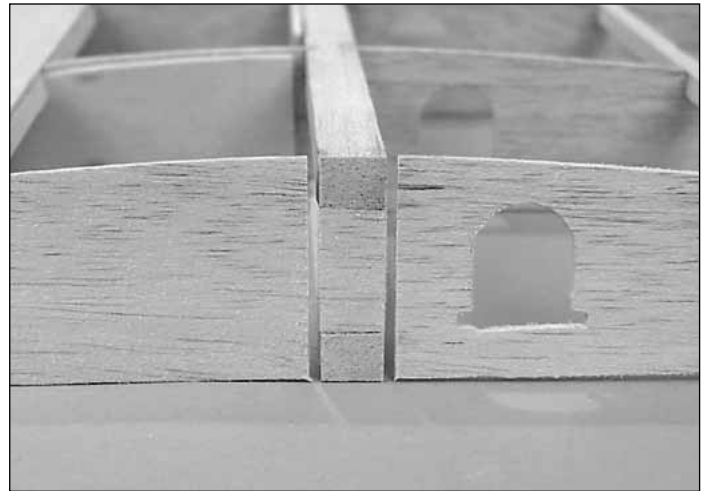

□ □ 28. Mark a line 1/16" away from each side of the main spars on the root rib. Carefully cut the root rib to allow the wing joiners to pass through. Without gluing, test fit the outer and center sections together. Make any adjustments as necessary for a good fit. We will join them after the other panel is built.

□ □ 29. Now is the time to clean up your mess and build the other wing panel just like the first one, only over the other wing panel plan.

Join the Wing Panels

□ 1. Double check that both wing panels fit with the center section properly and that the mating ribs fit well without any undue gaps between them. Sand as needed for a good fit.

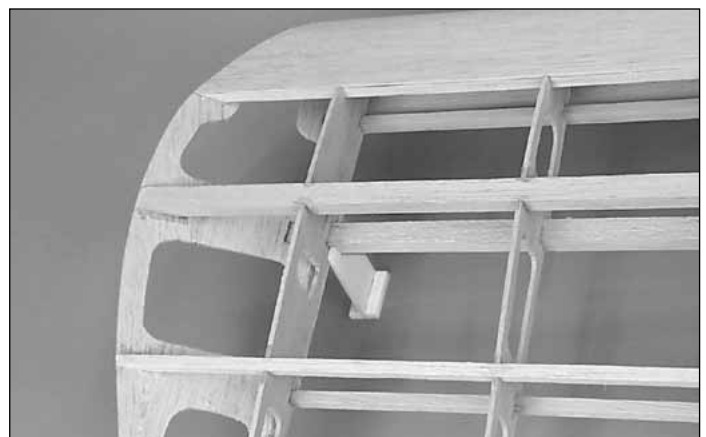
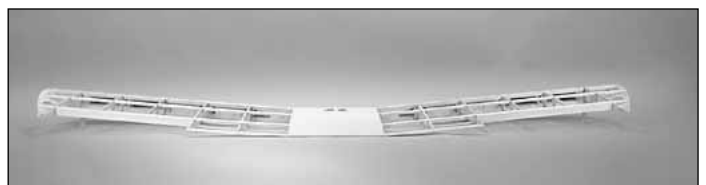

□ 2. Mix about 1/2 ounce of 30-minute epoxy. Working over wax paper or Plan Protector, coat the inside surfaces of the 1/16" die-cut ply **wing joiners (WJ)**, one wing panel and the mating surfaces of the root ribs with epoxy. Slide the panels together and raise the tip with the wing tip support. Clamp

the parts together and pin the LE and TE in alignment. Repeat this operation for the other wing tip. Weight the center section down flat on the board and recheck all joints. Let the wing assembly fully cure before moving it. Once the epoxy has cured, sand all joints smooth.

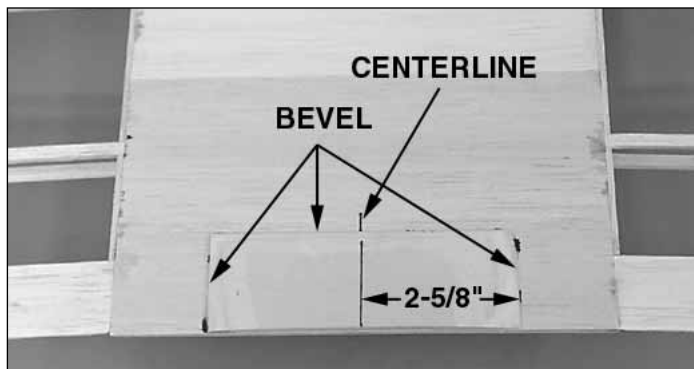

□ 3. Locate one of the 1/8" die-cut ply **wing bolt plates (BP)**. Sand a bevel on one long side and both short ends. Measure and mark a centerline 2-5/8" from one end. Measure and mark a front to rear centerline on the bottom of the wing center panel. With reference to the lines you just drew, center and glue the wing bolt plate to the bottom of the wing with the **unbeveled** edge flush with the TE of the wing.

Well, you are more than half way through the framing stage, so clean up your workbench, have a soda and let's build the fuse.

BUILD THE FUSELAGE

Build the Lower Fuselage

NOTE: The fuse is built **upside-down** over the plan. The plan sheet may be cut apart if space is a problem.

□ 1. Cover the **side view** of the fuse plan with wax paper or Plan Protector.

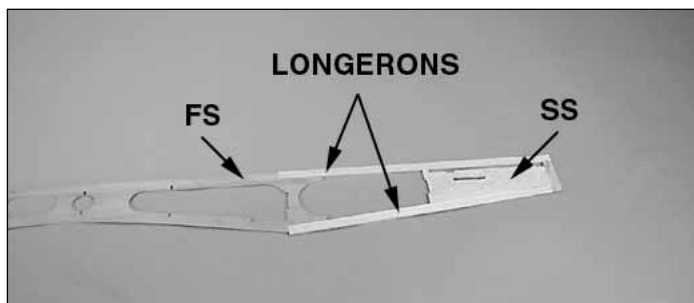

□ 2. Position and pin a 1/8" die-cut **ply fuse side (FS)** over the plan. Pin the 1/8" die-cut balsa **stab saddle (SS)** over the plan at the aft end of the fuse. With reference to the plan, cut a 1/8" x 1/2" x 36" balsa stick to make the top and bottom **longerons**. Glue these sticks to the forward fuse

side and the stab saddle. Cut a short piece of leftover 1/8" x 1/2" balsa stick to fit between the longerons at the rear of the fuse aft of the stab saddle. Make a second fuse side to match this one. Sand them smooth.

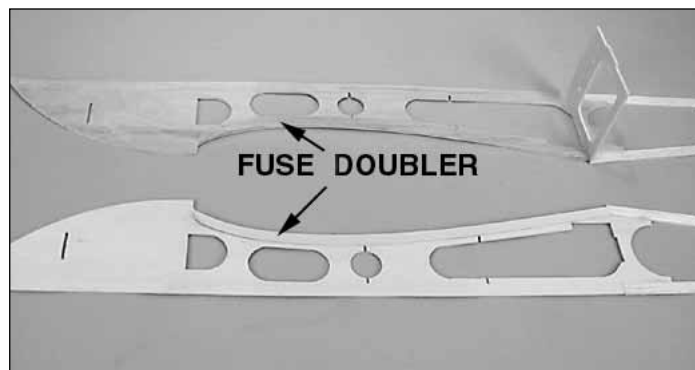

□ 3. Position the 1/8" die-cut ply former F-5 in the fuse side. **DO NOT GLUE.** Use F-5 to locate the rear end of the die-cut 1/8" ply **fuse doubler (FD)**. Glue the doubler in place. Repeat for the other fuse side. **NOTE:** Be sure to build a left and a right fuse side.

□ 4. Cover the bottom view of the plan with wax paper or Plan Protector. Position the 1/8 die-cut ply **forward fuse top (FFT)** over the plan, being careful to **align the engine mount area exactly to the plan**. If this piece is not correctly placed you will build in the wrong engine thrust angle. As we are building the fuse upside down, you should be able to see a 3 degree *left thrust* angle to the engine mount. Pin the fuse top in position.

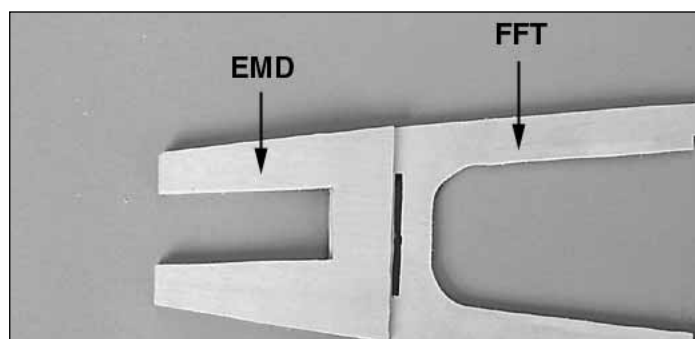

□ 5. Align and glue (use 6-minute epoxy) the 1/8" die-cut ply **engine mount doubler (EMD)** to the surface of the fuse top that is facing up.

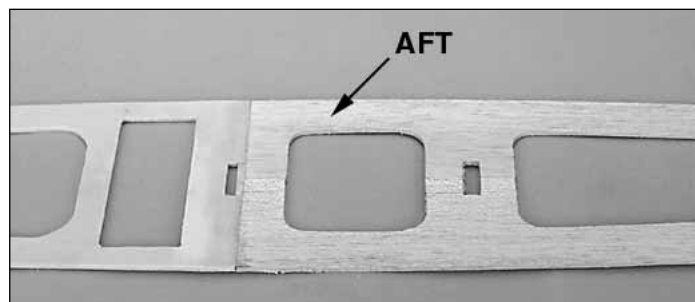

□ 6. Glue both halves of the 1/8" die-cut balsa **aft fuse top (AFT)** together. Position this assembly over the plan and glue it to the forward fuse top. Pin it in position.

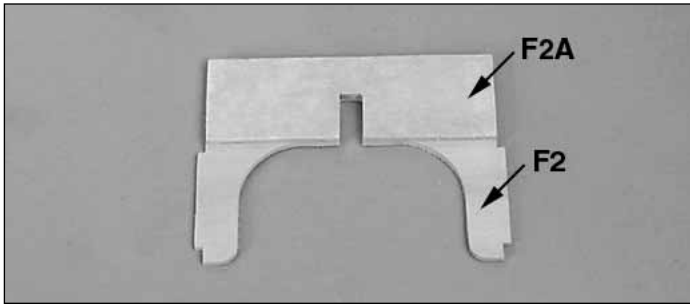

□ 7. Locate 1/8" die-cut ply formers F2 and F2A. Glue them together with thick CA.

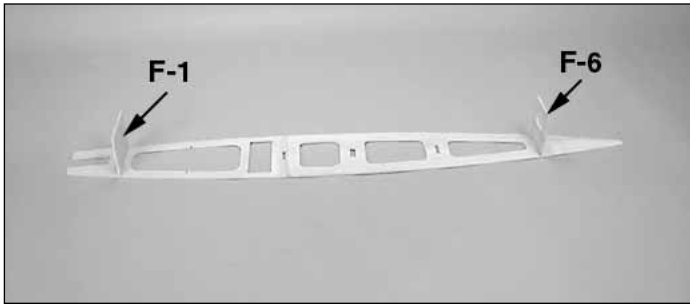

□ 8. Install the 1/8" die-cut ply **formers F1 and F6** in their respective slots in the fuselage top. Glue them in position with thin CA.

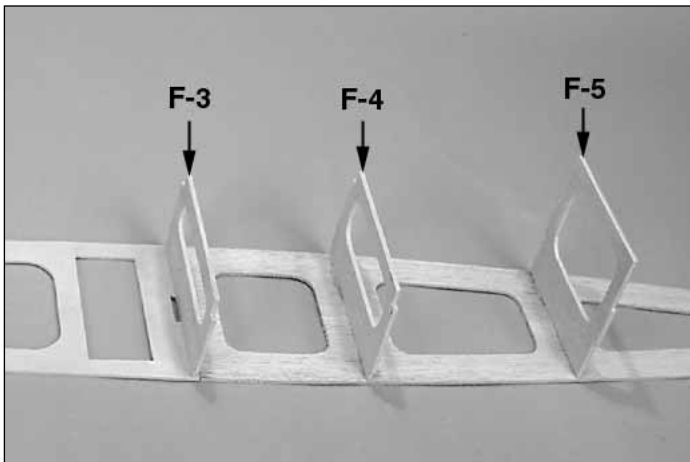

□ 9. Install 1/8" die-cut ply **formers F4, F5** at the *forward* edge of their respective notches and **F3** at the rear of its notch. Square and glue them to the fuselage top.

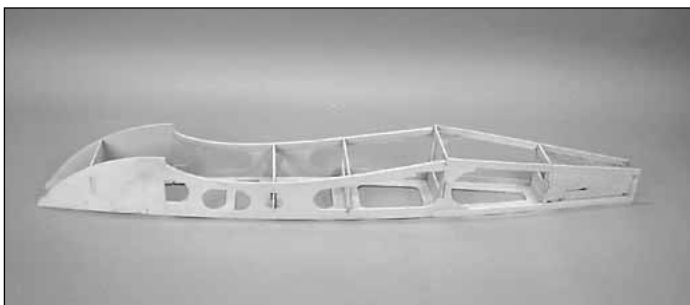

□ 10. Align one of the **fuselage sides** with F1 with the wing saddle pointing up. Test fit the side along the length of the fuselage. When satisfied with the fit, **tack** glue it in place. Repeat this procedure with the other fuselage side.

□ 11. Insert the **F2/2A former** into the notches in the fuselage sides with the doubler facing the nose of the fuselage.

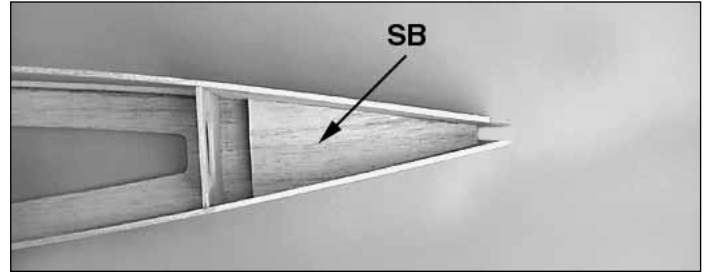

□ 12. Slide the 1/8" die-cut balsa **stab base (SB)** into position at the rear of the fuselage. When satisfied that all formers and the sides are aligned and everything is fitting properly, wick thin CA into all joints to permanently glue the fuselage together. Apply medium or thick CA if needed to fill any small gaps.

□ 13. Cut two 36" outer pushrod tubes to 22". Sand the surface of the tubes with 80-grit sandpaper. Slide the tubes into the rudder and elevator guide holes in formers F3 - F6 and out of the stab saddle. Glue them in place. Fill the space around the exit slots with balsa filler, then sand the tube flush with the stab saddle once the filler has dried.

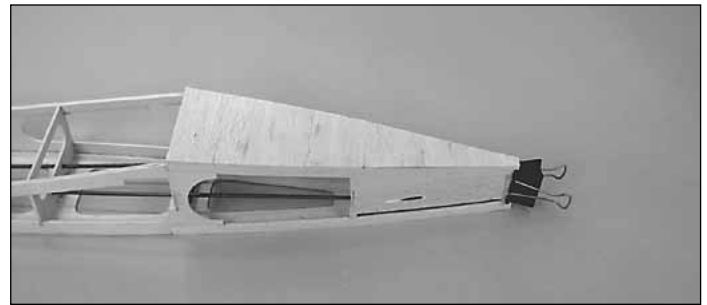

□ 14. Insert, but do not glue a piece of leftover 1/4" x 1/2" balsa between the fuselage sides at the aft of the fuselage to simulate a tail post. Pin or clamp the sides to it, but be sure it does not protrude past the bottom of the fuselage sides. Use a 3/32" x 3" x 36" sheet to sheath the bottom of the fuselage from F5 to the tail. The grain must run across the width of the fuselage. Sand the sheeting flush with the fuselage sides. The dummy tail post may now be removed.

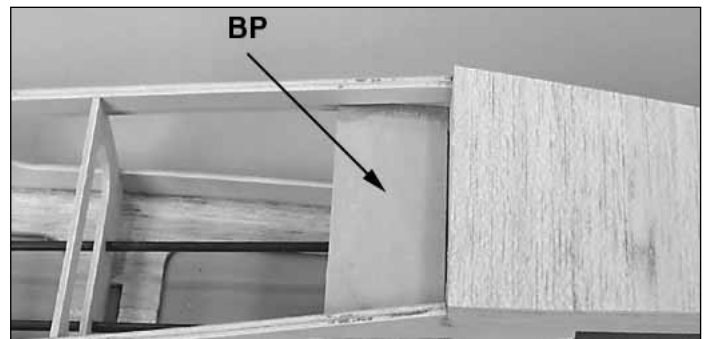

□ 15. Glue the three remaining 1/8" die-cut ply **bolt plates (BP)** together with 6-minute epoxy. Use 6-minute epoxy to glue the bolt plate assembly into the notch just forward of F5 and also to F5 itself.

❑ 16. Remove the fuse bottom from the board and sand off any glue blobs or rough spots.

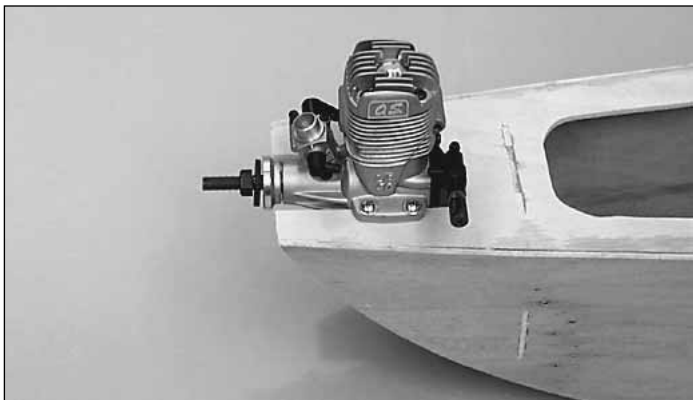

❑ 17. Position your engine in the engine mount with the front edge of the thrust washer $\frac{3}{16}$ " ahead of the engine mounting plate. **Note:** If the opening is too narrow, sand or file **both edges equally** to make them wider. Mark the location of the engine mounting holes. **Hint:** a *Great Planes Dead Center marking tool* is great for this purpose. Remove the engine.

❑ 18. To prevent splintering, hold a piece of leftover hardwood under the engine mount, then drill a $\frac{1}{8}$ " diameter hole through each mark. Turn the fuse over and install a 4-40 blind nut in each hole. Seat them with a hammer or draw them into position by temporarily bolting the engine in place using the supplied 4-40 x $\frac{3}{4}$ " machine screws and #4 washers. Apply a drop of thin CA to each blind nut flange to hold them in place. Don't get CA into the threads.



❑ 19. Use a $\frac{3}{32}$ " x 3" x 36" to sheet the bottom of the fuse from the wing saddle to the nose. The grain must run across the width of the fuse. Sand the sheeting flush with the fuse sides.

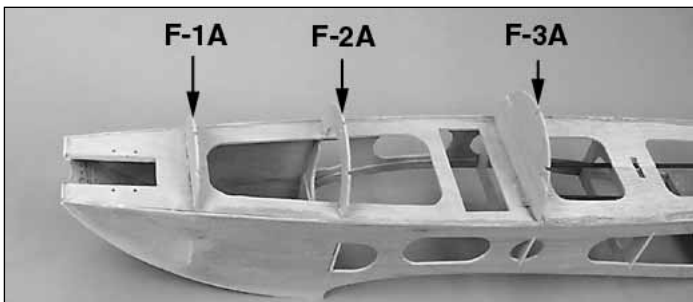

❑ 20. Install $\frac{3}{32}$ " die-cut balsa formers **F1A, F2A** and **F3A**. Make sure they are vertical with a square, then glue them in place.

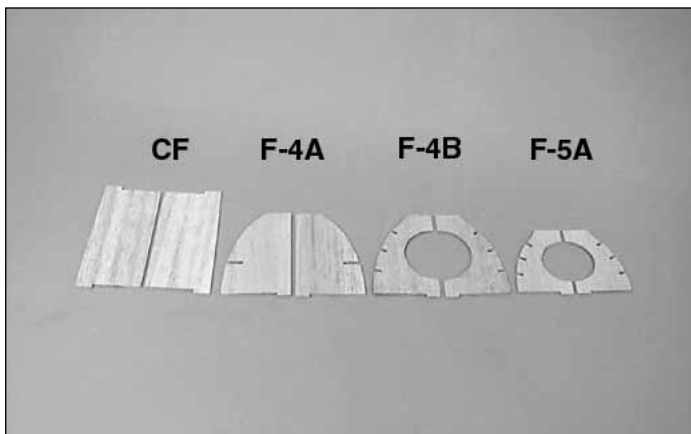

❑ 21. Glue each of the two halves of the $\frac{1}{8}$ " die-cut balsa cockpit floor (**CF**), **F4A**, **F4B**, and **F5A** together.

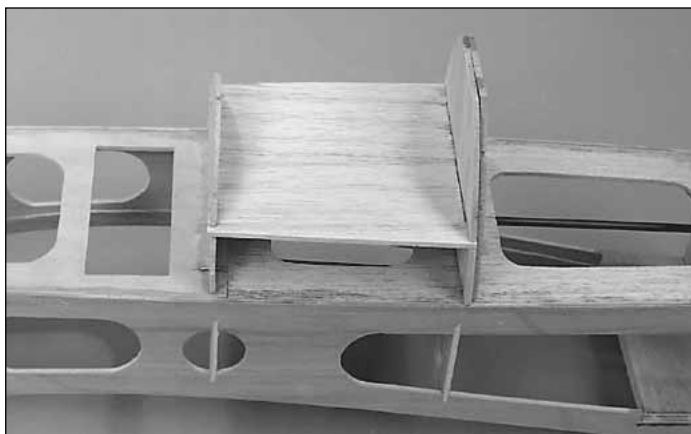

❑ 22. Insert the forward tabs of the cockpit floor into the notches of F3A. Insert die-cut balsa F4A into its notch, then plug the floor into the notches in F4A. Insert die-cut balsa former F4B behind F4A and check that everything is aligned and centered. When everything is positioned, apply thin CA to glue all of the pieces in place and to each other.

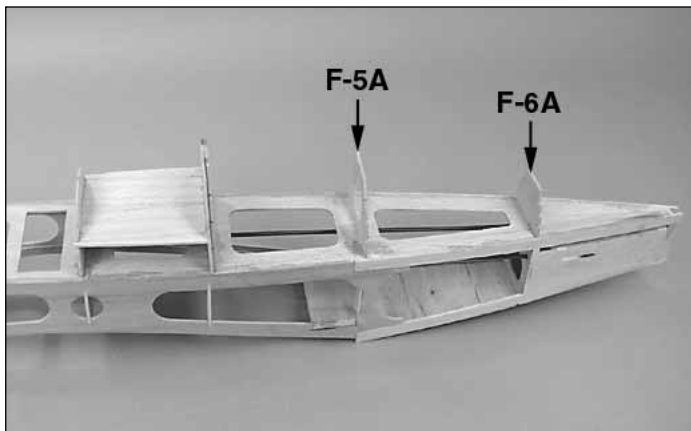

❑ 23. Glue the $\frac{1}{8}$ " die-cut balsa formers **F5A** and **F6A** in position.

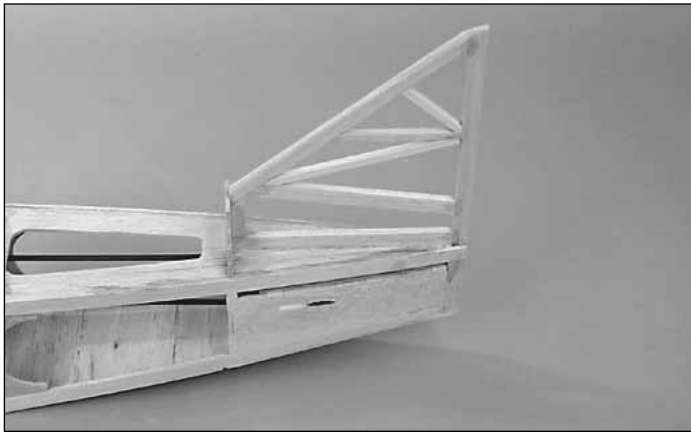

□ 24. Slide the tailpost of the vertical fin into position at the rear of the fuse. The forward edge of the fin should be flush against the back of F6 and centered side to side. Use a square to check that the fin is perpendicular to the fuse top and make adjustments as needed if it is not. When satisfied with the fit, glue the fin in position with thick CA. Pinch the fuse sides tightly to the tail post until the CA has cured.

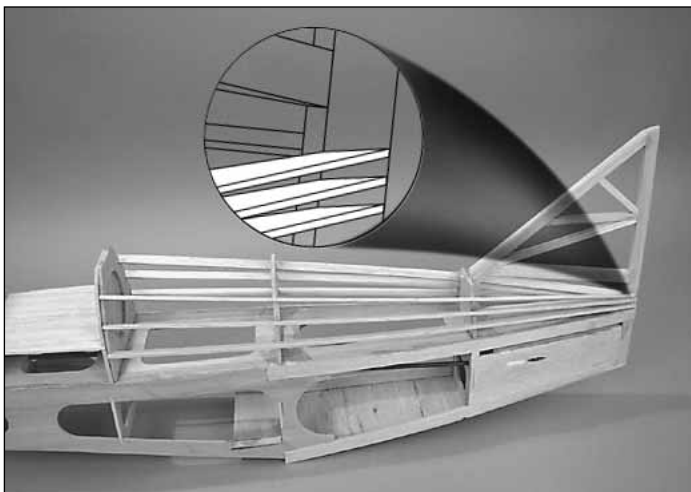

□ 25. Measure, cut and glue the 1/8" x 3/8" x 24" balsa **stringers** to fit the turtle deck from F4 to the TE of the fin. Bevel the rear end of each stick to fit flush with the tail post. (See inset photo of bevel) Fit all 6 stringers at this time.

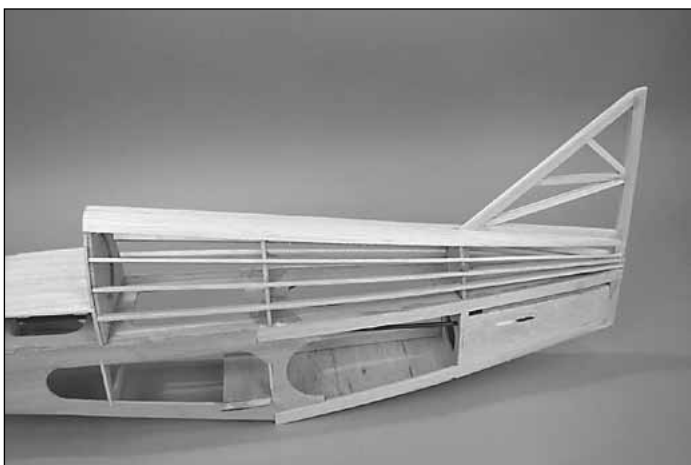

□ 26. Use the pattern on the plan to cut the 5/16" x 2" x 24" balsa **turtle deck top** to size. Work slowly to obtain a good

fit. Use a razor plane and sanding bar to do as much of the shaping as you can before gluing it in place. Once satisfied with the shape and fit, glue the turtle deck top to the top of the aft fuse formers and the tail post.

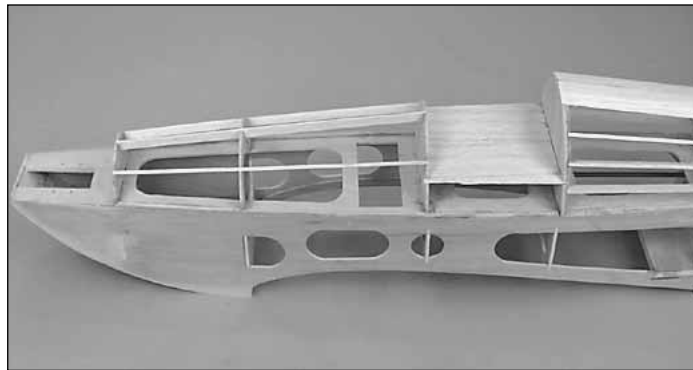

□ 27. Measure, cut and glue the three 1/8" x 3/8" x 12" balsa **stringers** to fit between F1A and F3A. Measure, cut and glue the 1/8" x 1/8" x 36" balsa gluing stringer into the notches at the bottom of F1A - F3A and up to F4A. (See photo at step 29.)

□ 28. Cut a sheet of 3/32" x 3" x 36" balsa to make three pieces 12" long. Edge glue the three pieces together making a 3/32" x 9" x 12" piece.

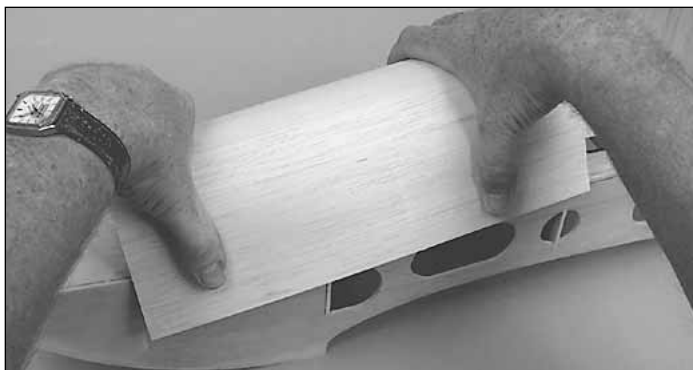
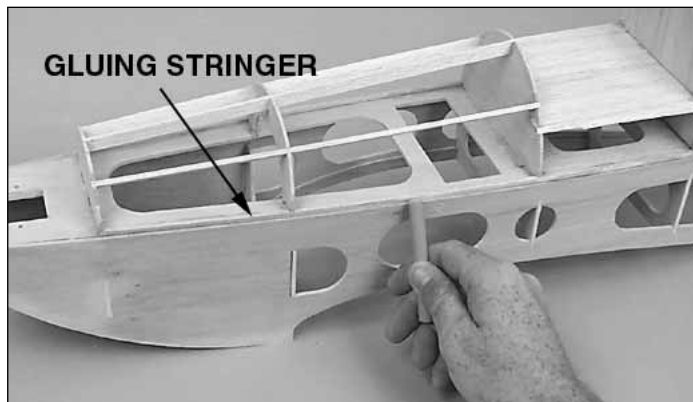

□ 29. Rub a piece of colored chalk along the top edges of the lower fuse as shown. Wet the outside surface of the sheet you just made and flex it with your hands to *soften* it up. Wrap the sheeting around the front deck formers, pressing the bottom edges against the fuse that is coated with chalk. Remove the sheet and cut along the chalk lines. Recheck the fit and adjust as needed. When satisfied with the fit, glue the sheet in place with medium CA.

❑ 30. Trim the front of the front deck sheeting flush with front edge of F1A. Trim the aft end of the sheeting flush with aft side of F3A.

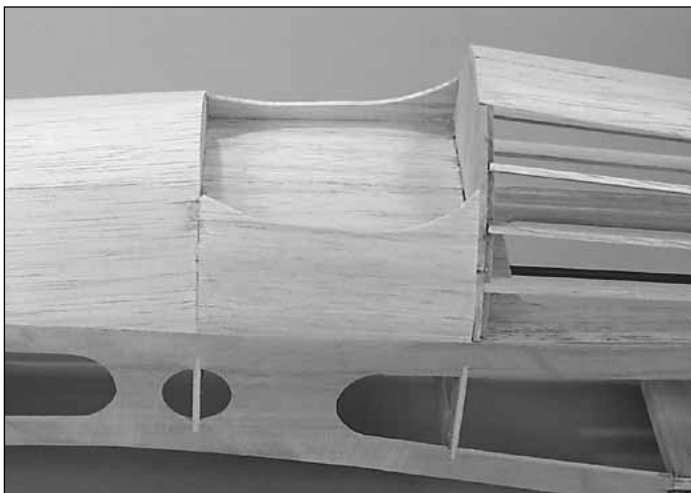

❑ 31. Use the pattern on the plan to cut and fit a sheet of 3/32" x 3" balsa to fill in the space between F3A and F4A. The pattern is slightly over size to allow for fine tuning and adjustment.

❑ 32. Fill any depressions, gaps and surface blemishes with balsa colored filler and rough sand the fuse to blend all parts.

Install the Tail Gear

❑ 1. Refer to the plan for the location of the tail gear "arm" on the rudder and mark the position. Drill a 3/32" hole into the rudder's LE 3/4" deep at this mark. Cut a 1/8" diameter groove from the bottom of the rudder to the hole you just drilled. Insert the tail gear "arm" into the hole, then hold the rudder up to the fin TE. Center the rudder top to bottom.

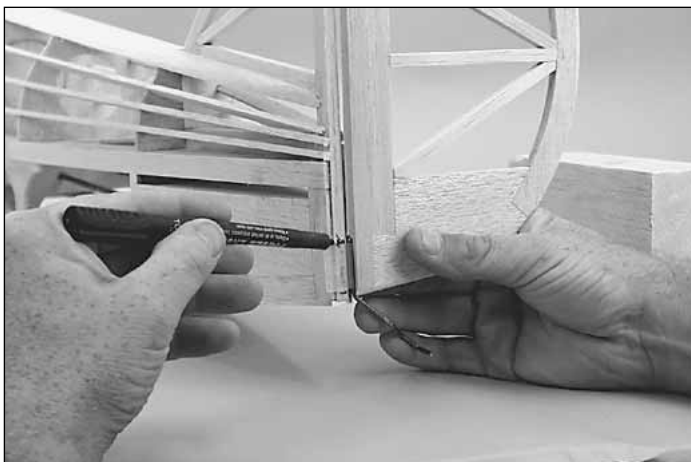

❑ 2. Mark the location of the **tail gear bearing** on the aft edge of the fuse. Cut a slot in the center of the tail post to accept the tail gear bearing.

Hint: A Great Planes "Slot Machine"™ motorized slotting tool works great for this operation!

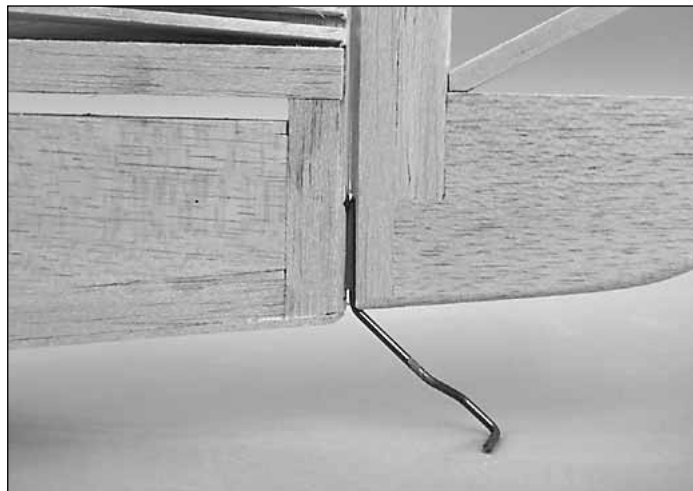

❑ 3. Temporarily install the bearing and rudder. The **rudder should fit flush** with the fin and aft edge of the fuse. If not, check if the bearing is fully seated or that the groove in the rudder is deep enough. The bearing won't be glued in place until after the model is covered.

Fit the Wing & Stab

❑ 1. Support the fuse upside down in any type of cradle. If you don't own a "store bought" unit, a simple cardboard box with "U" shaped cut-outs at each end will work fine. Put an old towel into the U's to prevent damaging the model.

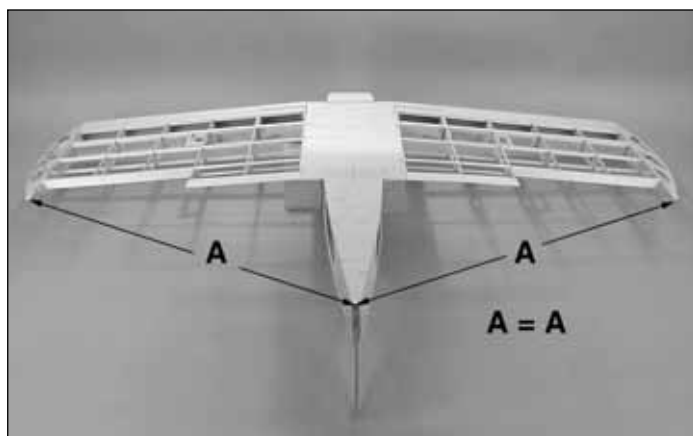

❑ 2. Place the wing into the saddle and check that it is properly seated. If not, make minor adjustments with your sanding bar to correct any problems. Measure the distance from the center of the tail post to each wing tip and shift the wing until the distance is equal. Mark a reference line across the aft edge of the wing onto the bottom fuse sheeting.

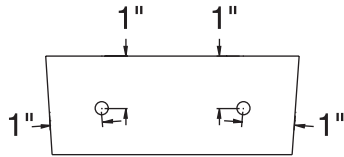

□ 3. Using the sketch as a guide, measure and mark the location of the two wing bolt holes. While securely holding the wing in alignment with the reference marks you made in the previous step, drill #10 or 13/64" holes, perpendicular to the bottom of the wing, through the wing **into** the wing bolt plate. Remove the wing and enlarge the holes in only the wing to 17/64". Tap the holes in the bolt plate with a 1/4-20 tap. A few drops of thin CA in the threads will harden them. Retap the holes after the CA has fully cured.

□ 4. Mount the wing using two nylon 1/4-20 x 2" wing mounting bolts.



□ 5. Turn the fuse over and slide the stab into the stab saddle. Stand back about ten feet and view the model from the rear. If the stab tips are not an equal height above the wing, remove the stab and sand the high side of the saddle until the stab is aligned.

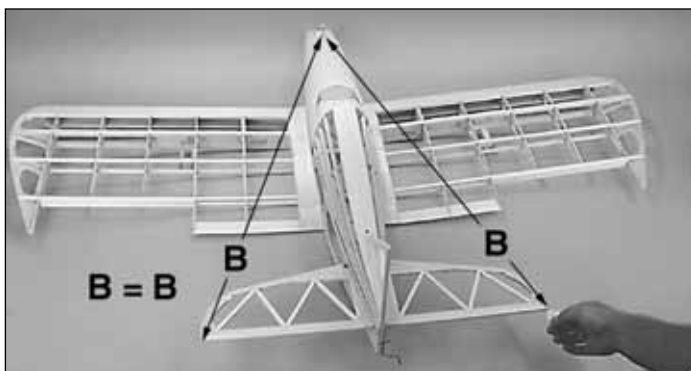

□ 6. Center the stab side to side in the fuse. Measure the distance from each tip to a pin centered on top of the fuse at the nose. When the distance is equalized, mark the stab and fuse with some reference marks. Glue the stab in position with 6-minute epoxy. **NOTE:** The stab should be pushed forward as far as possible to allow room for the elevator joiner.

Wow! That wasn't too difficult was it? You should now have a great looking frame-up ready to cover. Gulp some coffee and let's pull an all-nighter !

FINISHING

Final Sanding



Many surface blemishes on a framed model are caused by bumps and balsa chips on the work surface. This type of ding is best repaired by applying a drop or two of window cleaner or tap water to the blemish, then running a sealing iron over the spot to expand the wood fibers. After the surface has dried, sand the *expanded* area smooth.

□ 1. Fill any scuffs, dings and the forward end of the pushrod tube exit slots with balsa filler. Sand the entire structure with progressively finer grades of sandpaper, ending with 320-grit.

Fuelproofing

Fuelproofing may be done either before or after covering.

□ 1. Fuelproof the engine compartment, paying special attention to the firewall. LustreKote® paint or 30-minute epoxy is recommended.

□ 2. Fuelproof any external exposed wood.

Balance the Airplane Laterally

SPECIAL NOTE: Do not confuse this procedure with "checking the C.G." or "balancing the airplane fore and aft." That very important step will be covered later in the manual.

Now that you have the basic airframe nearly completed, this is a good time to balance the airplane **laterally** (side-to-side). Here is how to do it:

□ 1. Temporarily attach the wing and engine (with muffler) to the fuselage.

□ 2. With the wing level, lift the model by the engine propeller shaft and the fin post (this may require two people). Do this several times.

□ 3. If one wing always drops when you lift the model, it means that side is heavy. Balance the airplane by gluing weight to the other wing tip. **NOTE: An airplane that has been laterally balanced will track better in loops and other maneuvers.**

Cover the Model

The technique we will describe here is the how the model pictured on the box was finished. Make sure the structure is smoothly sanded with **320-grit** sandpaper. Remove all dust from the structure with a **Top Flite Tack Cloth** so the MonoKote will stick well.

Cover the aircraft with MonoKote using the sequence below. Make sure the MonoKote is thoroughly stuck to the structure and all of the edges are sealed. Use a **Top Flite MonoKote Hot Sock™** on your covering iron to avoid scratching the MonoKote.



MONOKOTE TECHNIQUE

You can practically eliminate MonoKote wrinkles that sometimes occur when the model is left out in the sun or in the back of your car by following this technique used in the **Great Planes** model shop:

- A. Cover your sealing iron with a **Top Flite Hot Sock** and turn the heat about 3/4 of the way to the high setting.
- B. Say we are going to cover the Stab — cut a piece of MonoKote film about 2" larger all around. Strip off the backing and position the film. Tack the film down **at the center of the LE and TE.**
- C. Pull (as in stretch) the film toward the tip, sealing it to the balsa. Stretch and tack it to the root end.
- D. Pull and seal **diagonally toward the four corners**, always starting from the center. The trick is to shrink out any wrinkles before you seal the film to the surface.
- E. Use a heat gun to heat and stretch the film around curved surfaces like the stab and rudder tips, while pulling on the excess material. You may need to pull hard to get out all of the wrinkles, so wear a glove if you need to. Follow-up the heat gun with your sealing iron to secure the bond.

The idea behind this approach (which can be applied to any part of the model) is to **pre-stretch the MonoKote** as it's applied and remove the air pockets that can expand later which cause the sags and wrinkles.

When covering areas that involve sharp junctions, like the tail section, cut narrow strips (3/8" to 1/2") and apply them in the corners **before** covering the major surfaces. The larger pieces of MonoKote will overlap and capture these smaller pieces. This technique also bypasses the need to cut the MonoKote in these areas after it has been applied.

DO NOT, under any circumstances, attempt to cut the covering material after it has been applied to the fin and stab, except around the leading and trailing edges and the tip. Modelers who do this often cut through the covering and part-way into the balsa stab skin. This can weaken the stab to the point where it may fail in flight!

Recommended Covering Sequence

- 1. Tail Junction Strips as described above
- 2. Rudder left side
- 3. Rudder right side
- 4. Bottom of elevators
- 5. Top of elevators
- 6. Stab bottom
- 7. Stab top
- 8. Fin left side
- 9. Fin right side
- 10. Fuse bottom
- 11. Fuse sides
- 12. Fuse top
- 13. Ends of ailerons
- 14. Bottom of ailerons
- 15. Top of ailerons
- 16. Bottom of left wing panel
- 17. Bottom of right wing panel
- 18. Top of left wing panel (overlap 1/4" at wing LE)
- 19. Top of right wing panel (overlap 1/4" at the LE)

FINAL HOOKUPS & CHECKS

Install the Tank & Throttle Pushrod

- ❑ 1. Assemble your tank and then hold it up inside the fuse to mark the location of the fuel tubes. Drill a 1/4" hole for both the supply tube and the pressure tube.

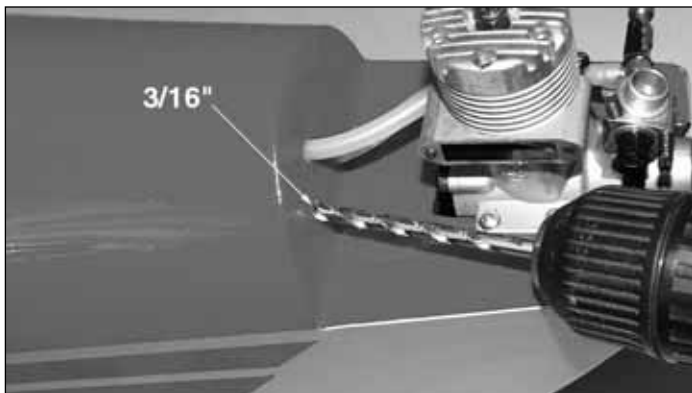

- ❑ 2. With your engine in position, use a sharpened length of wire to mark the location of the throttle pushrod onto the firewall. Drill a 3/16" hole on this mark.

- ❑ 3. Sand a 12" outer pushrod tube to roughen it up. Slide it into the firewall and downward toward the servo tray. Cut or drill additional passages as needed. Glue it to the firewall leaving about 1/2" protruding.

- ❑ 4. Install the fuel tank, leaving about 6" of fuel tubing poking through the firewall. The tank should be padded with 1/2" foam rubber and supported by a couple of leftover sticks glued to the fuse sides.

Install the Control Surfaces

Mark the location of all hinges on the control surfaces and mating surfaces. Start with the stab and elevators.

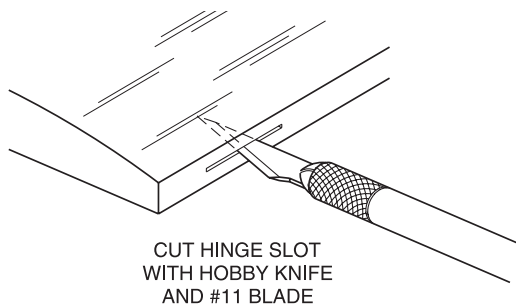

- ❑ 1. Cut the hinge slot using a #11 blade in a standard #1 knife handle. The CA hinges provided have a thickness that fits this type of slot very well. Trial fit the hinge into the slot. If the hinge does not slide in easily, work the knife blade back and forth in the slot a few times to provide more

clearance (it is really the **back edge** of the blade that does the work here in widening the slot).

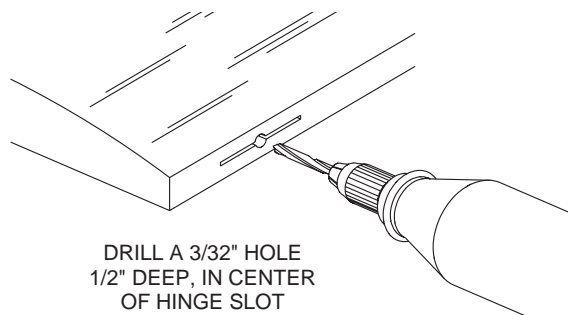

- ❑ 2. **Drill a 3/32" hole, 1/2" deep, in the center of the hinge slot.** If you use a Dremel® tool for this task, it will result in a cleaner hole than if you use a slower speed power or hand drill. Drilling the hole will twist some of the wood fibers into the slot, making it difficult to insert the hinge, so you should re-insert the knife blade, working it back and forth a few times to clean out the slot.

- ❑ 3. Cut 1" x 3/4" hinges from the hinge material provided. Trial fit the hinges into the slots and temporarily attach the control surface, to verify the fit and operation.

- ❑ 4. Rather than just making a single slit, it is better to cut away a narrow rectangle of covering to provide an adequate opening for the CA glue to wick into the slot.

- ❑ 5. Insert the hinges and install the control surface. Verify the left-right positioning of the control surface and close up the hinge gap to 1/32" or less. It is best to leave a very slight hinge gap, rather than closing it up tight, to help prevent the CA from wicking along the hinge line. Make sure the control surface will deflect to the recommended throws without binding. If you have cut your hinge slots too deep, the hinges may slide in too far, leaving only a small portion of the hinge in the control surface. To avoid this, you may **insert a small pin** through the center of each hinge, before installing. This pin will keep the hinge centered while you install the control surface. Remove the pins before proceeding.

- ❑ 6. Insert the **elevator joiner wire** through the opening in the tail at the rear of the stab saddle. Fill the hole you drilled in the elevator with 30-minute epoxy, then insert the wire arm all the way in. Make sure that both elevators are level with each other. Work all of the hinges into position and secure them with a few drops of thin CA on both sides of each hinge.

- ❑ 7. Cut the hinge slots for the rudder and test fit the rudder to the fin with the tail gear in position. When satisfied with the fit, remove the rudder. Then use 30-minute epoxy to fasten the tail gear bearing into the fuse. Coat the wire where it passes through the bearing with petroleum jelly to prevent it from becoming glued to the bearing.

- ❑ 8. Pack the tail gear hole in the rudder with epoxy, then install the rudder in the same way as the elevator using three hinges.

Install the Landing Gear

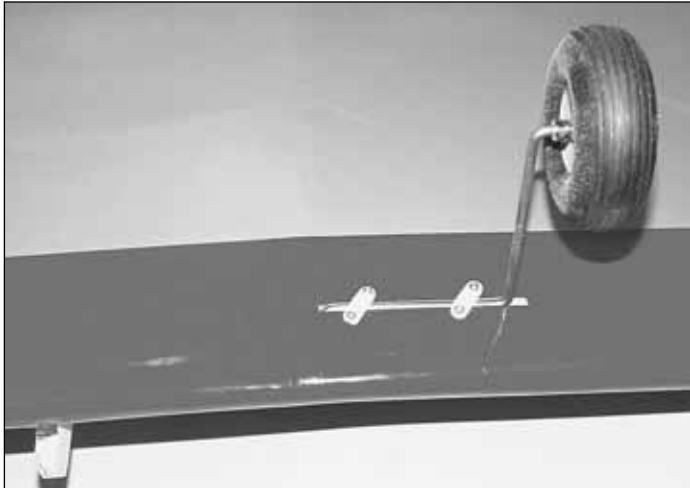

□ □ 1. Seat the landing gear in the groove on the bottom of the wing. Secure it with two **nylon straps** and four **#2 x 3/8"** sheet metal screws per strut.

□ □ 1. Secure the main wheels to the landing gear with two **5/32"** wheel collars (not included). File a flat spot on the axle to capture the set screw.

□ 2. Secure the tail wheel to the tail wheel gear leg with a **3/32"** wheel collar.

Radio Installation

□ 1. Mount three servos in the servo tray following the manufacturer's recommendations. Install "cross" style horns on all servos.

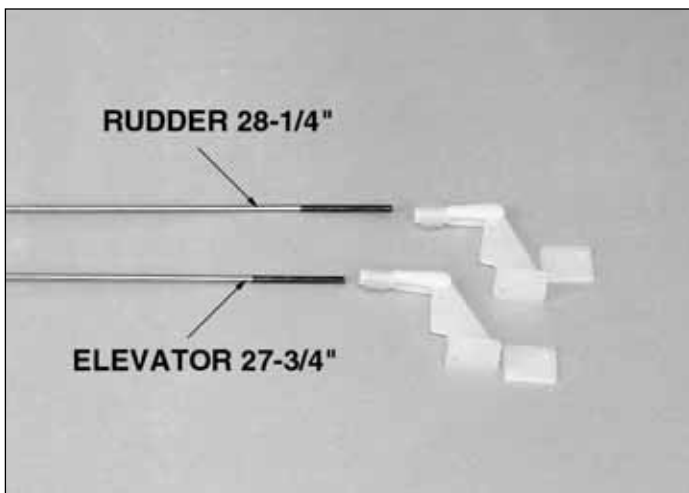

□ 2. Slide a **silicone retainer** over the "hex" end of a **nylon clevis**. Screw the clevis 14 turns onto the threaded end of a **36"** wire pushrod. Cut the unthreaded end to shorten the wire to **27-3/4"**. Trim the backing plate from a **nylon control horn**, then clip the clevis to the outer hole of the horn. Make a second pushrod assembly that is **28-1/4"** in length.

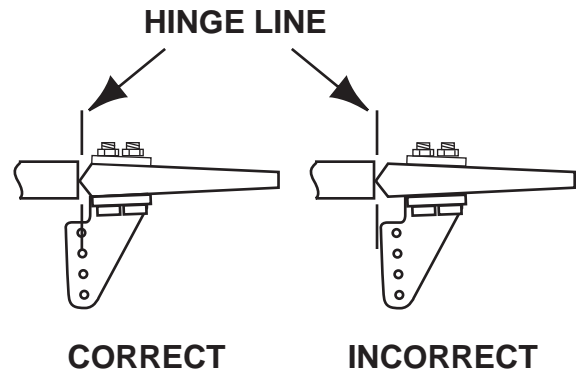
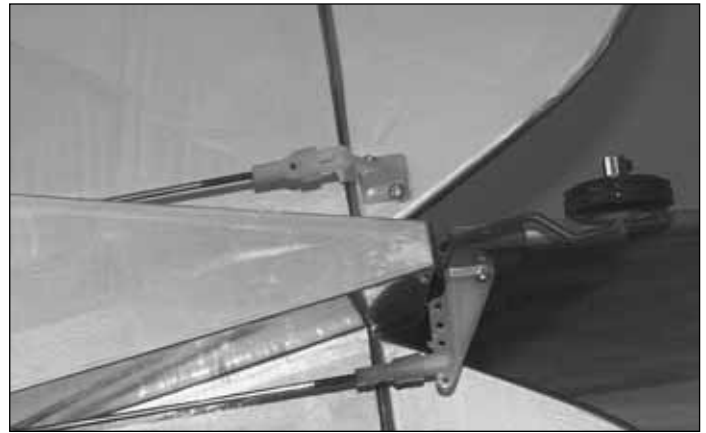

□ 3. Insert the pushrods into the tubes in the fuse from the tail, then hold a horn in position on either the elevator or rudder (see sketch above for correct alignment). The pushrod should not be bent and should slide easily in the tube. Mark the location for the horn screws on the control surface. Drill the **3/32"** horn screw holes through the control surface, then prick a few pin holes into the wood under the horn's location. Apply a drop or two of thin CA to the pin holes to strengthen the wood. When cured, screw the horn in place with two 2-56 machine screws and the backing plate. Repeat for the other control surface.

□ 4. Connect the receiver to the servos, switch and battery. Turn on your transmitter and receiver, then center the elevator and rudder servo. *Be sure that the trim levers are centered.*

□ □ 5. Center the elevator, then mark the pushrod where it crosses the **second servo horn hole from the center**. Enlarge the servo horn hole with a **5/64"** drill bit.

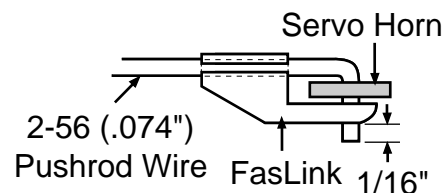

□ □ 6. Make a ninety degree bend in the pushrod on your mark then insert it through the enlarged hole in the servo horn. Secure it in place with a **nylon Faslink™**.

□ 7. Repeat steps 5 and 6 for the rudder.



❑ 8. Hookup the throttle using the 12" white nylon pushrod, 1" threaded stud and nylon clevis at the throttle and the 4" threaded wire and brass pushrod connector at the servo. Make sure that the servo does not stall at either end of its travel.

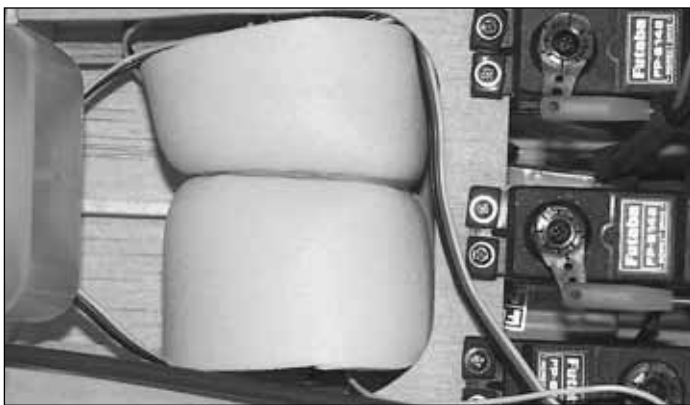

❑ 9. Wrap your receiver in a plastic bag, then wrap it with foam rubber. Secure the foam with a couple of rubber bands. Temporarily secure the receiver in the cavity just ahead of the servos as shown.

❑ 10. Route the receiver **antenna** out of the fuselage bottom behind the wing. Anchor the antenna to the tail gear with a rubber band. Be sure to put a strain relief on the antenna where it exits the fuse.

❑ 11. Mount the receiver switch and charging jack through the fuselage on the opposite side of the fuse to the muffler exhaust. We suggest using a Great Planes **Switch/Charging Jack Mount** (GPMM #1000) because of its ease of installation and tidy appearance.

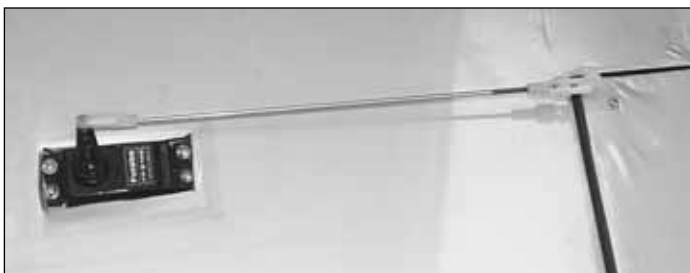

❑ 12. Install the aileron servos and pushrods as shown using two 12" **wire pushrods, clevises** and **Faslinks**. Fish the servo leads through to the center of the wing and plug them into a Y-harness.

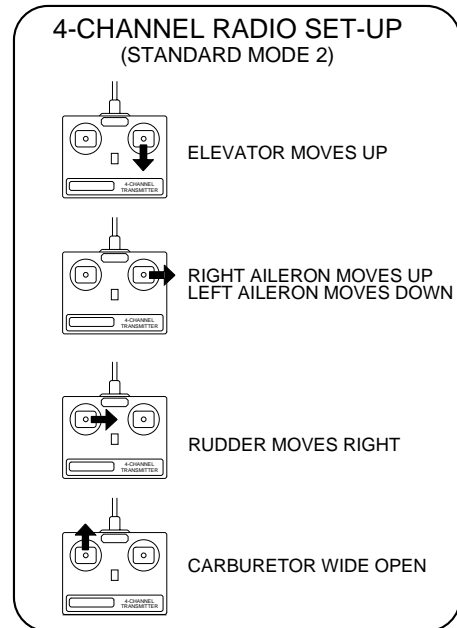

❑ 13. Turn on the radio system and check the direction of all control functions. They must all move in the direction shown in the sketch. If not, change the position of the reversing switches on your transmitter.

Control Surface Throws

We recommend the following control surface throws:

NOTE: Throws are measured at the **widest part** of the elevators, rudder and ailerons.

	High Rate	Low Rate
ELEVATOR:	7/16" up 7/16" down	1/4" up 1/4" down
AILERONS:	1" up 1" down	3/4" up 3/4" down
RUDDER:	1-1/2" left 1-1/2" right	

NOTE: If your radio does not have "dual rates," then set up the control surfaces to move between the **high rate** and **low rate** throws.

NOTE: The balance and surface throws for this aircraft have been extensively tested. We are confident that they represent the settings at which the SlowPoke Sport 40 flies best. Please set up your aircraft to the specifications listed above. If, after a few flights, you would like to adjust the throws to suit your tastes, that's fine. Too much throw can force the plane into a stall, so remember, "*more is not better.*"

Balance Your Model

NOTE: This section is VERY important and must NOT be omitted! A model that is not properly balanced will be unstable and possibly unflyable.

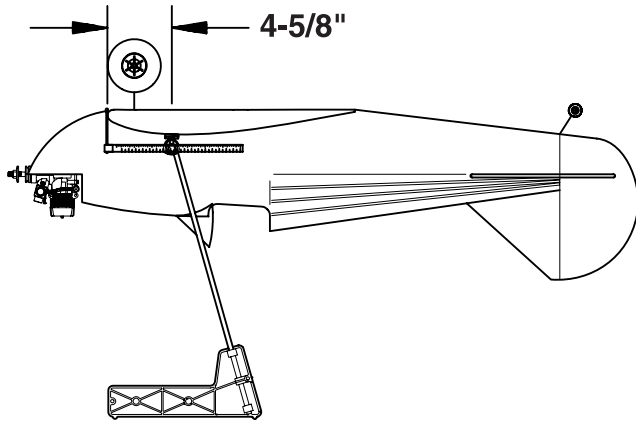

□ 1. Accurately mark the balance point on the **top** of the wing on both sides of the fuselage. The balance point is shown on the plan (CG) and is located **4-5/8" back from the leading edge** as shown in the sketch and on the plan. **Hint:** Use the full-size wing plan to help you accurately locate the proper balance point on the wing. This is the balance point at which your model should balance for your first flights. Later, you may wish to experiment by shifting the balance up to **3/8" forward or back** to change the flying characteristics. Moving the balance **forward** may improve the smoothness and arrow-like tracking, but it may then require more speed for takeoff and make it more difficult to slow down for landing. Moving the balance **aft** makes the model **more agile** with a lighter and snappier "feel" and often improves aerobatic capabilities. In any case, **please start at the location we recommend and do not at any time balance your model outside the recommended range.**

□ 2. With the wing attached to the fuselage, all parts of the model installed (ready to fly) and an **empty** fuel tank, hold the model upside down with the stabilizer level.

□ 3. Lift the model at the balance point. If the tail drops when you lift, the model is "tail heavy" and you must add weight* to the nose to balance. If the nose drops, it is "nose heavy" and you must add weight* to the tail to balance.

NOTE: Nose weight may be easily installed by using a Heavy Spinner Hub or gluing lead weights into the engine compartment. Tail weight may be added by using Great Planes (GPMQ4485) "stick-on" lead weights and, later, if the balance proves to be OK you can open the fuse bottom and glue these in permanently.

**If possible, first attempt to balance the model by changing the position of the receiver battery and receiver. If you are unable to obtain good balance by doing so, then it will be necessary to add weight to the nose or tail to achieve the proper balance point.*

PREFLIGHT

Charge the Batteries

Follow the battery charging procedures in your radio instruction manual. You should **always** charge your transmitter and receiver batteries the night before you go flying and at other times as recommended by the radio manufacturer.

Find a Safe Place to Fly

The best place to fly your R/C model is an AMA (Academy of Model Aeronautics) chartered club field. Ask your hobby shop dealer if there is such a club in your area and join. Club fields are set up for R/C flying and that makes your outing safer and more enjoyable. The AMA also can tell you the name of a club in your area. We recommend that you join AMA and a local club so you can have a safe place to fly and have insurance to cover you in case of a flying accident. (The AMA address is listed on page 2 of this instruction book).

If a club and its flying site are not available, you need to find a large, grassy area at least 6 miles away from any other R/C radio operation like R/C boats and R/C cars and away from houses, buildings and streets. A schoolyard may look inviting but it is too close to people, power lines and possible radio interference.

Ground Check the Model

If you are not thoroughly familiar with the operation of R/C models, ask an experienced modeler to check to see that you have the radio installed correctly and that all the control surfaces do what they are supposed to. The engine operation also must be checked and the engine "broken-in" on the ground by running the engine for at least two tanks of fuel. **Follow the engine manufacturer's recommendations for break-in.** Check to make sure all screws remain tight, that the hinges are secure and that the prop is on tight.

Range Check Your Radio

Wherever you do fly, you need to check the operation of the radio before every time you fly. This means with the transmitter antenna collapsed and the receiver and transmitter on, you should be able to walk at least 100 feet away from the model and still have control. Have someone help you. Have them stand by your model and, while you work the controls, tell you what the various control surfaces are doing. Repeat this test **with the engine running** at various speeds with an assistant holding the model. If the control surfaces are not always acting correctly, **do not fly!** Find and correct the problem first.

Engine Safety Precautions

NOTE: Failure to follow these safety precautions may result in severe injury to yourself and others.

Keep all engine fuel in a safe place, away from high heat, sparks or flames, as fuel is very flammable. Do not smoke near the engine or fuel; and remember that the engine exhaust gives off a great deal of deadly carbon monoxide. Therefore **do not run the engine in a closed room or garage.**

Get help from an experienced pilot when learning to operate engines.

Use safety glasses when starting or running engines.

Do not run the engine in an area of loose gravel or sand; as the propeller may throw such material in your face or eyes.

Keep your face and body as well as all spectators away from the plane of rotation of the propeller as you start and run the engine.

Keep items such as these away from the prop: loose clothing, shirt sleeves, ties, scarfs, long hair or loose objects (pencils, screw drivers) that may fall out of shirt or jacket pockets into the prop.

Use a "chicken stick" device or electric starter; follow instructions supplied with the starter or stick. Make certain the glow plug clip or connector is secure so that it will not pop off or otherwise get into the running propeller.

Make engine adjustments from **behind** the rotating propeller.

The engine gets hot! Do not touch it during or after operation. Make sure fuel lines are in good condition so fuel will not leak onto a hot engine causing a fire.

To stop the engine, cut off the fuel supply by closing off the fuel line or follow the engine manufacturer's recommendations. Do not use hands, fingers or any body part to try to stop the engine. Do not throw anything into the prop of a running engine.

AMA Safety Code (excerpts)

Read and abide by the following Academy of Model Aeronautics Official Safety Code:

General

1. I will not fly my model aircraft in sanctioned events, air shows, or model flying demonstrations until it has been proven to be airworthy by having been previously successfully flight tested.
2. I will not fly my model aircraft higher than approximately 400 feet within 3 miles of an airport without notifying the airport operator. I will give right of way to and avoid flying in the proximity of full scale aircraft. Where necessary an observer shall be used to supervise flying to avoid having models fly in the proximity of full scale aircraft.

3. Where established, I will abide by the safety rules for the flying site I use and I will not willfully and deliberately fly my models in a careless, reckless and/or dangerous manner.
7. I will not fly my model unless it is identified with my name and address or AMA number, on or in the model.
9. I will not operate models with pyrotechnics (any device that explodes, burns, or propels a projectile of any kind).

Radio Control

1. I will have completed a successful radio equipment ground check before the first flight of a new or repaired model.
2. I will not fly my model aircraft in the presence of spectators until I become a qualified flier, unless assisted by an experienced helper.
3. I will perform my initial turn after takeoff away from the pit or spectator areas and I will not thereafter fly over pit or spectator areas, unless beyond my control.
4. I will operate my model using only radio control frequencies currently allowed by the Federal Communications Commission.

FLYING

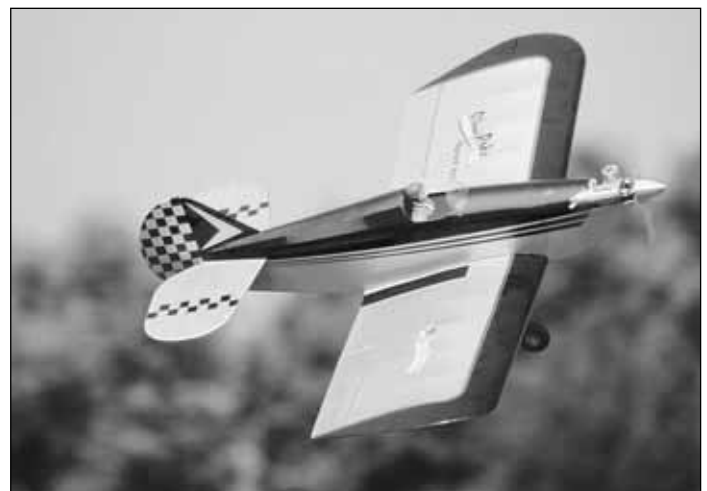

The Great Planes SlowPoke Sport 40 is a great flying sport airplane that flies smoothly and predictably, yet is highly maneuverable. Compared to other sport planes, its flight characteristics are very docile and forgiving. It does not, however, have the self-recovery characteristics of a primary R/C trainer; therefore, you must either have mastered the basics of R/C flying or obtained the assistance of a competent R/C pilot to help you with your first flights.

Balance the Propeller

Balance your propellers carefully before flying. An unbalanced prop is the single most significant cause of damaging vibration. Not only will engine mounting screws and bolts vibrate out, possibly with disastrous effect, but vibration will also damage your radio receiver and battery. Vibration will cause your fuel to foam, which will, in turn, cause your engine to run rough or quit.

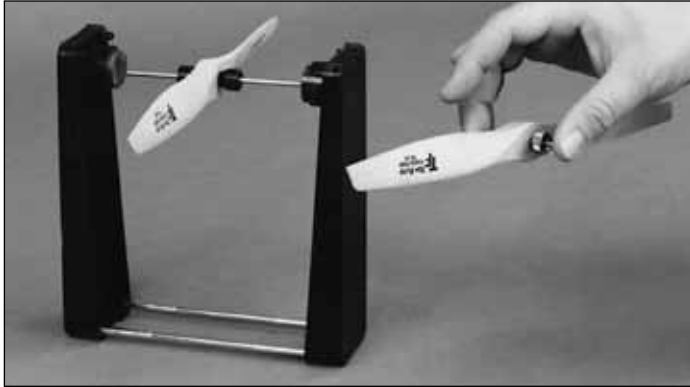

We use a **Top Flite Precision Magnetic Prop Balancer** (#TOPQ5700) in the workshop and keep a **Great Planes Fingertip Balancer** (#GPMQ5000) in our flight box.

Takeoff

If you have dual rates on your transmitter, set the switches to “high rate” for takeoff, especially when taking off in a crosswind. Although this model has excellent low speed characteristics, you should always build up as much speed as your runway will permit before lifting off, as this will give you a safety margin in case of a “flame-out.” Start your takeoff roll pointing directly into the wind if possible. When you first advance the throttle and the tail begins to lift, the plane will start to turn left (a characteristic of all “tail draggers”). Be ready for this and correct by applying sufficient right rudder to hold it straight down the runway. The left-turning tendency will go away as soon as the tail is up and the plane picks up speed. Be **sure** to allow the tail to come up. Don’t hold the tail on the ground with too much up elevator, as the SlowPoke Sport 40 will become airborne prematurely and will possibly stall. When the plane has sufficient flying speed, (this should only take 50’ or so on a paved surface, about 100’ off short grass!) lift off by smoothly applying up elevator (don’t “jerk” it into a steep climb!) and climb out gradually.

Flight

We recommend that you take it easy with your SlowPoke Sport 40 for the first several flights, gradually “getting acquainted” with this classic sport plane as your engine

gets fully broken-in. Add and practice one maneuver at a time, learning how she behaves in each. For ultra-smooth flying and normal maneuvers, we recommend using the “low rate” settings as listed on page 26. “High rate” elevator may be required for rolls, spins and tight loops.

CAUTION (THIS APPLIES TO ALL R/C AIRPLANES): If, while flying, you notice any unusual sounds, such as a low-pitched “buzz,” this may be an indication of control surface “flutter.” Because flutter can quickly destroy components of your airplane, any time you detect flutter you must **immediately** cut the throttle and land the airplane! Check all servo grommets for deterioration (this will indicate which surface fluttered) and make sure all pushrod linkages are slop-free. If it fluttered once, it probably will flutter again under similar circumstances unless you can eliminate the slop or flexing in the linkages. Here are some things which can result in flutter: Excessive hinge gap; Not mounting control horns solidly; Sloppy fit of clevis pin in horn; Elasticity present in flexible plastic pushrods; Side-play of pushrod in guide tube caused by tight bends; Sloppy fit of Z-bend in servo arm; Insufficient glue used when gluing in the elevator joiner wire or aileron torque rod; Excessive flexing of aileron, caused by using too soft balsa aileron; Excessive “play” or “backlash” in servo gears; and insecure servo mounting.

Landing



When it’s time to land, fly a normal landing pattern and approach into the wind. Always try to land directly into the wind as directional control is much easier and you don’t have to worry about the wind getting under one of those huge wing panels and possible flipping it over. Keep a few clicks of power on until you are over the runway threshold. For your first landings, plan to land slightly faster than stall speed and on the main wheels, as this is the easiest way to land your SlowPoke Sport 40. Later, with a little technique, you will find you can make slow, 3-point landings.

Have a ball! But always stay in control and fly in a safe manner. GOOD LUCK AND GREAT FLYING!

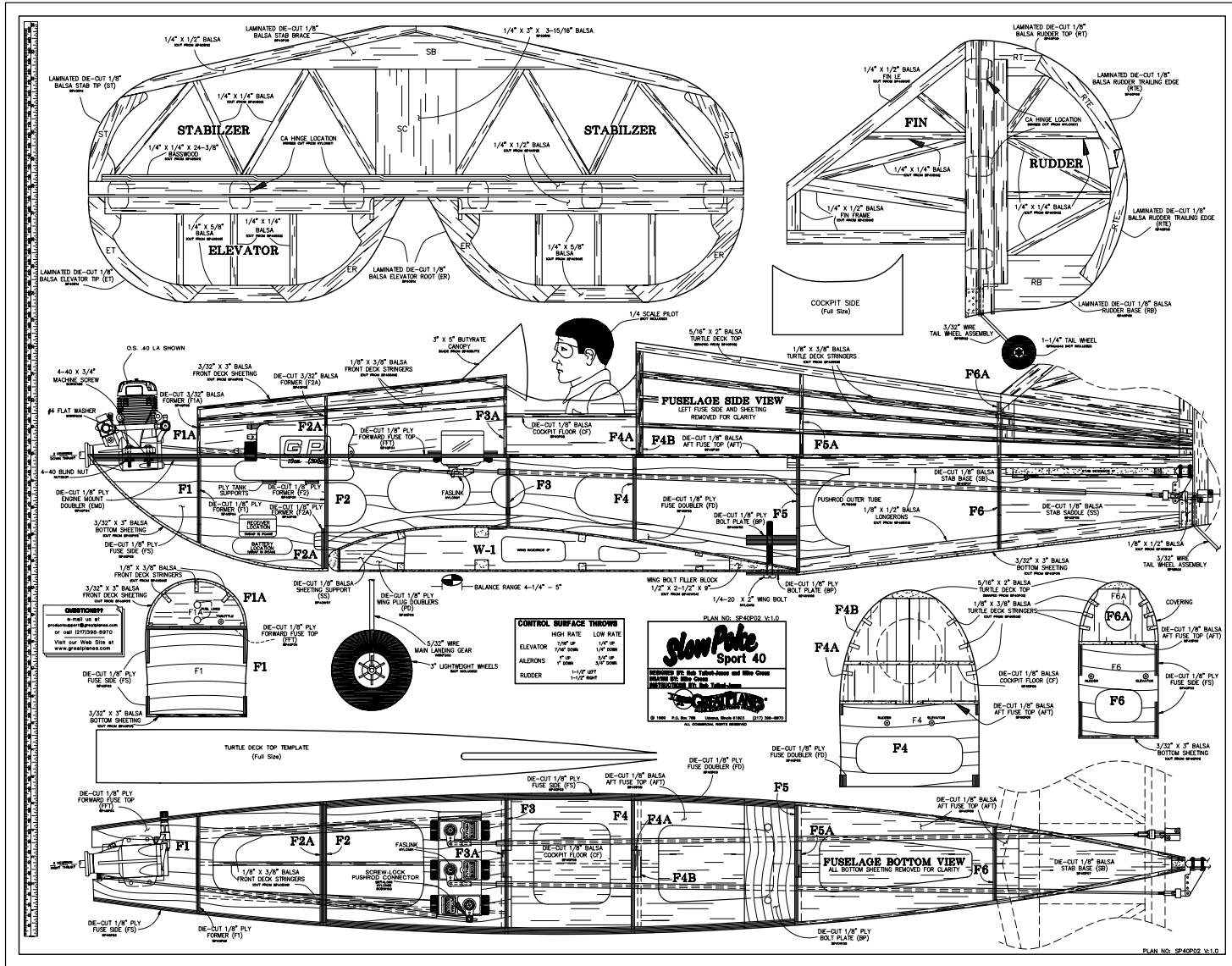

B

C

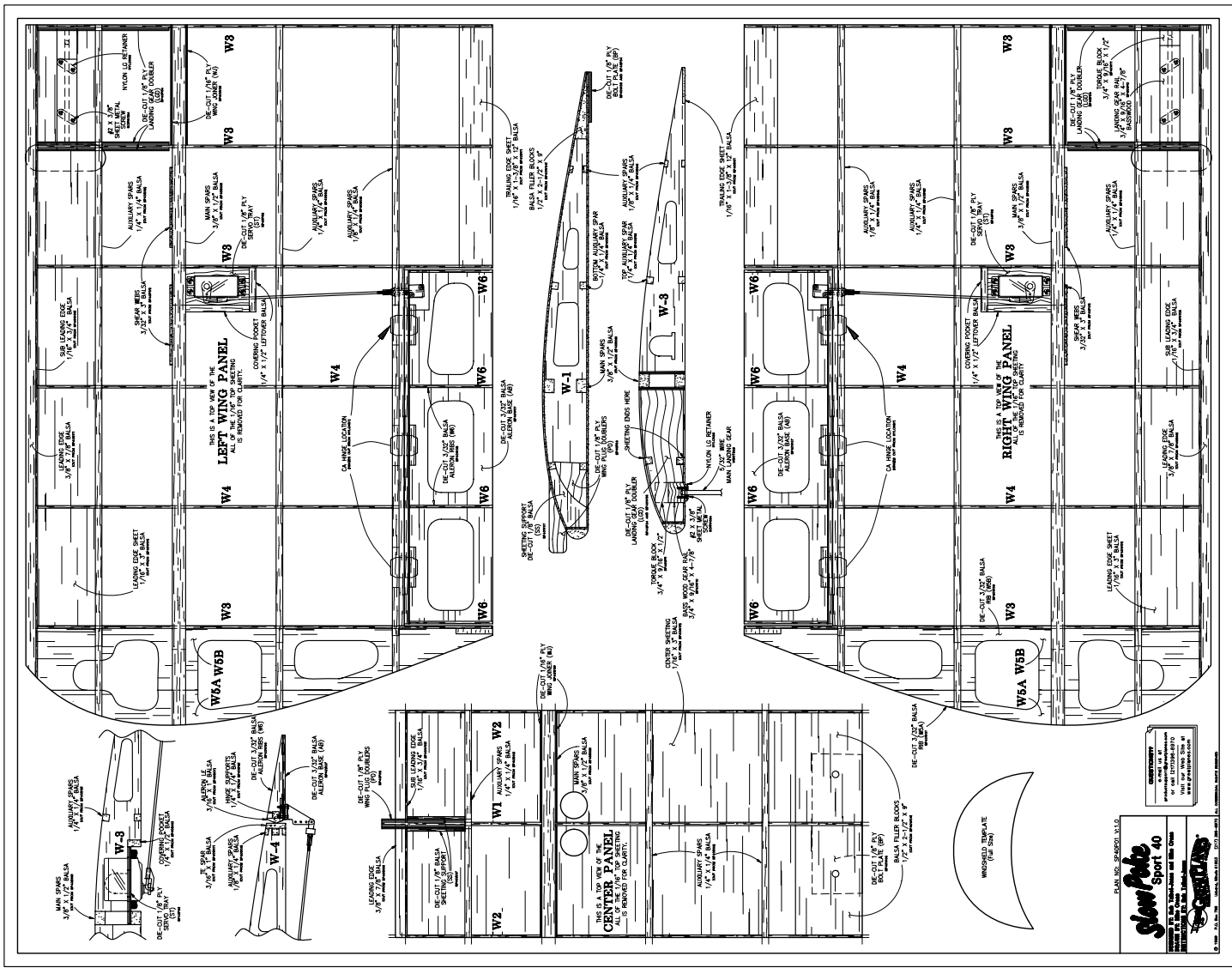

D

A

EQUIVALENT MATERIALS
slowRate
 Sport 40
 CONSTRUCTION
 THIS MODEL IS NOT
 TO BE CONSIDERED
 AS A TOY. IT IS
 MEANT TO BE USED
 AS A MODEL AIRCRAFT.
 USE OF THIS MODEL
 IS AT THE USER'S
 OWN RISK.
 © 2014, 2015, 2016, 2017, 2018
 SLOWRATE INC.