

SUPERMARINE

SPITFIRE MK.IXc

User Manual

1/7 Scale WWII Warbird

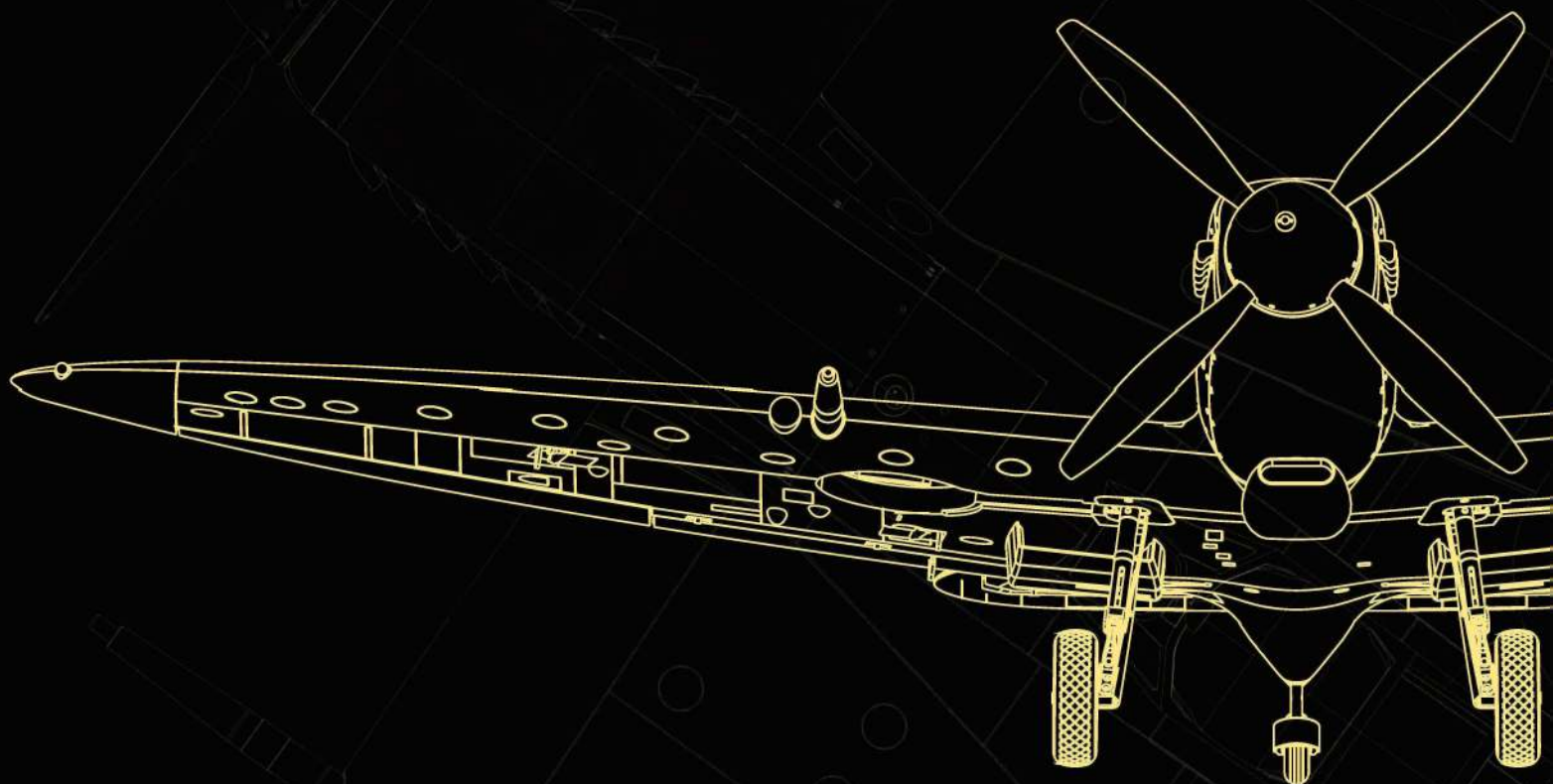

WINGSPAN : 1600MM (63")

LENGTH : 1350MM (53.1")

WEIGHT : 2850G (W/O BATTERY)

EN	1~12
中	13~24

Flightline
RC



Freewing
www.freewing.com
MADE IN CHINA



Catalog

Introduction	1
Basic Information	2
Package List	2
Assembly Instructions	
Fuselage Assembly	3
Horizontal stabilizer Assembly	3
Elevator/rudder Assembly	3
Aileron pushrod Installation	4
Main wing Assembly	4
Pushrod instructions	5
Scale Parts Installation	6
Introduction to the Control board	6
Battery Installation	7
Center of gravity	7
Control direction test	8
Dual Rates and Preflight Considerations	9
Accessories Description	
Servo Introduction	10
Motor Parameters	10
Power system Installation	11
Main landing gear Installation	12
Rear landing gear Installation	12
前言	13
产品基本参数	14
产品包装清单	14
PNP组装	
机身组装	15
平尾组装	15
平尾、垂尾钢丝安装	15
主翼钢丝安装	16
主翼组装	16
舵面控制钢丝尺寸	17
装饰件安装	18
集线盒使用说明	18
电池安装说明	19
重心示意图	19
舵面测试	20
大、小舵参数及飞行注意事项	21
配件说明	
舵机使用说明	22
电机参数	22
动力系统的安装	23
前起落架组装	24
后起落架组装	24

Thank you for purchasing the FlightlineRC 1600mm Spitfire Mk. IXc!

FlightlineRC is a leading brand produced by Freewing Models in partnership with Motion RC aimed at bringing you a new, exciting series of propeller driven aircraft at the same level of quality and value you've come to expect from Freewing Model's EDF aircraft and other products.

FlightLineRC inherits Freewing's goals of outstanding innovation, exquisite design, high quality, unbeatable value, and dependable performance.

The Supermarine Spitfire is one of the most popular warbirds in history. This British single-seat fighter was used famously by the Royal Air Force and the Allies, earning distinction during the Battle of Britain and throughout World War II. Over 20,300 aircraft were produced with more than 24 variants. The Spitfire's versatility and maneuverability made it a lethal aircraft against Axis forces. The Spitfire continues to fly in modern times as a tribute to aviation history and military veterans.

This FlightlineRC Spitfire Mk.IXc is approximately 1/7 scale, with a 1600mm wingspan and 1350mm length. It is molded from EPO foam, featuring a scale shape and smooth surface. The main wing is assembled from hollow parts and an interlocking plywood and carbon fiber frame, providing lower weight and higher strength than a solid foam wing. The main wing and horizontal tail are attached with screws for very convenient transport. Proper ventilation is also designed to keep the electronics cool. The large battery hatch and removable battery bay floor provides easy access to an organized battery and receiver compartment.

The stock PNP version is equipped with a 5055-390KV brushless outrunner motor and scale 4-blade propeller and BOA ESC. With the recommended 6S 4000-S000mAh lipo battery, the Spitfire MK.IXc has a level top speed of 125kph/75mph, with tall vertical power and 4-8 minutes of flight time depending on throttle management. To enhance grass performance, the main landing gear uses shock absorbing Oleo struts, a main wheel diameter of 85mm, and a tail wheel diameter of 45mm. Metal reinforcement plates, thick steel strut pins and axles, and metal trunions work together with the suspension struts and soft wheels to dampen the forces caused by operating this aircraft on rough runways. The FlightlineRC 1600mm Spitfire Mk.IXc was optimized for very gentle handling, suitable for intermediate pilots and above. The Take off, flying performance, and slow speed handling is especially stable. A very predictable stall and power on recovery make the aircraft easy to control throughout any aspect of flight. Bright LEDs also aid in the visibility of this large and beautiful foam electric model aircraft.

The FlightlineRC 1600mm Spitfire arrives completely painted and with national insignias pre-applied. To personalize your Spitfire, included in the box are two optional decal sets, depicting the aircraft of Squadron Leader F.A.O. Tony Gaze (MA621 DV-A) and Lieutenant Michel Boudier (BS383 GW-Z).

NOTE: This is not a toy. Not for children under 14 years. Young people under the age of 14 should only be permitted to operate this model under the instruction and supervision of an adult. Please keep these instructions for further reference after completing model assembly.

Note:

1. This is not a toy! Operators should have some basic experience. Beginners should operate only under the guidance of a professional instructor.
2. Before beginning assembly, please read through the instructions and carefully follow them through the build.
3. Freewing and it's vendors will not be held responsible for any losses due to improper assembly and operation.
4. Model airplane operators must be at least 14 years of age.
5. This airplane is made of EPO foam material, covered with surface spray paint. Don't use chemicals to clean as it may cause damage.
6. You should avoid flying in areas such as public places, areas with high voltage power lines, nearby highways or airports or an other areas where laws and regulations clearly prohibit flight.
7. Do not fly in bad weather conditions, including thunderstorms, snow, etc...
8. Lipo batteries should be properly stored in a fire safe container and be kept at a minimum of 2M distance away from flammable or explosive materials.
9. Damaged or scrap batteries must be properly discharged before disposal or recycling to avoid spontaneous combustion and fire.
10. At the Flying Field, properly dispose of any waste you have created, don't leave or burn your waste.. Ensure that your throttle is in the low position and that your radio is turned on before connecting the Lipo battery.

Product basic information

EN

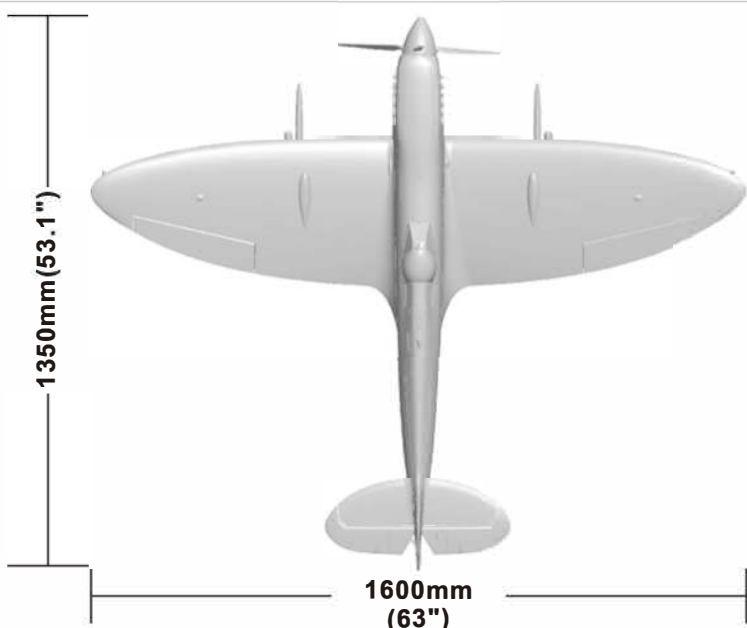

Wing loading: 74g/dm²
 Wing area : 46.5dm²
 Motor: 5055-390KV
 brushless outrunner motor
 Propeller : 4-Blade 16×10
 ESC: 80A (1pc)
 Servo: : 17g MG×6pcs
 Weight: 2850g (W/O battery)
 Flight speed : 125KM/H

Aileron: Yes
 Elevator: Yes
 Steering pushrod: Yes
 Flap: Yes
 LED lights : Yes
 Cabin door: Yes
 Landing gear: Retractable.
 Material: EPO Foam

Note:The parameters stated here are derived from test results using our accessories.
 If you use other accessories, the test results will differ. We cannot provide technical support if you have a problem when using other accessories.

Package list



Different kit types have different stock parts. Please refer to the following contents list for your type of kit to ensure all parts were included

No.	Name	PNP	ARF Plus	Airframe	No.	Name	PNP	ARF Plus	Airframe
1	Fuselage	Pre-installed all electronic parts	Pre-installed servo	No electronic equipment	7	Scale propeller	✓	✓	✓
2	Main wing	Pre-installed all electronic parts	Pre-installed servo	No electronic equipment	8	Carbon Fiber Rod	✓	✓	✓
3	Horizontal tail	Pre-installed all electronic parts	Pre-installed servo	No electronic equipment	9	Linkage Set	✓	✓	✓
4	Vertical tail	Pre-installed all electronic parts	Pre-installed servo	No electronic equipment	10	Glue & Non-slip mat	✓	✓	✓
5	Decorated part	✓	✓	✓	11	Manual & Decals	✓	✓	✓
6	Spinner	✓	✓	✓	12	Screw & Plastic fo	✓	✓	✓

PNP Assembly Instructions

EN

Fuselage Assembly

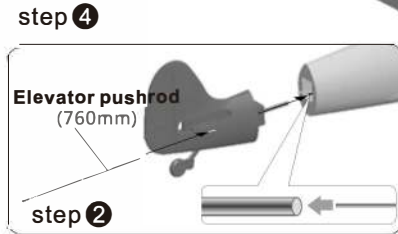
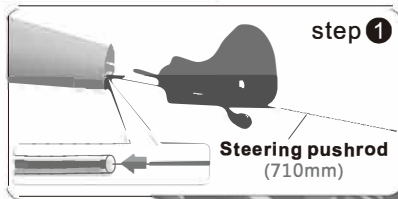

1. Before assembly, remove the battery compartment and the fuselage pushrods in the plastic tube. Install the ball-head buckle on the pushrods. Then insert the rudder pushrod from tail fuselage section into the front fuselage plastic tube.
2. Insert the elevator pushrod from tail fuselage section to the front fuselage plastic tube.
3. Use the included epoxy glue to attach the front and rear fuselage. During the gluing process, take special care to ensure that NO GLUE enters the plastic control rod tube! If any glue does enter the tubing it will inhibit the control rods ability to function, therefore impeding the aircraft's ability to fly. Proper execution of the build is the responsibility of the builder, Any such damage is not covered by the manufacturer or vendor warranty.
4. Use the included epoxy glue to attach the foam parts A and B to the fuselage.

Note: EPO glue is included with the kit. Spread the glue evenly and wait 90 seconds before installation.

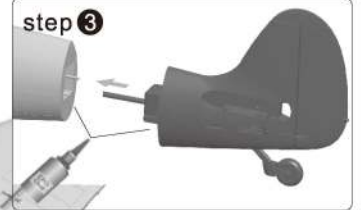

Horizontal Stabilizer Assembly

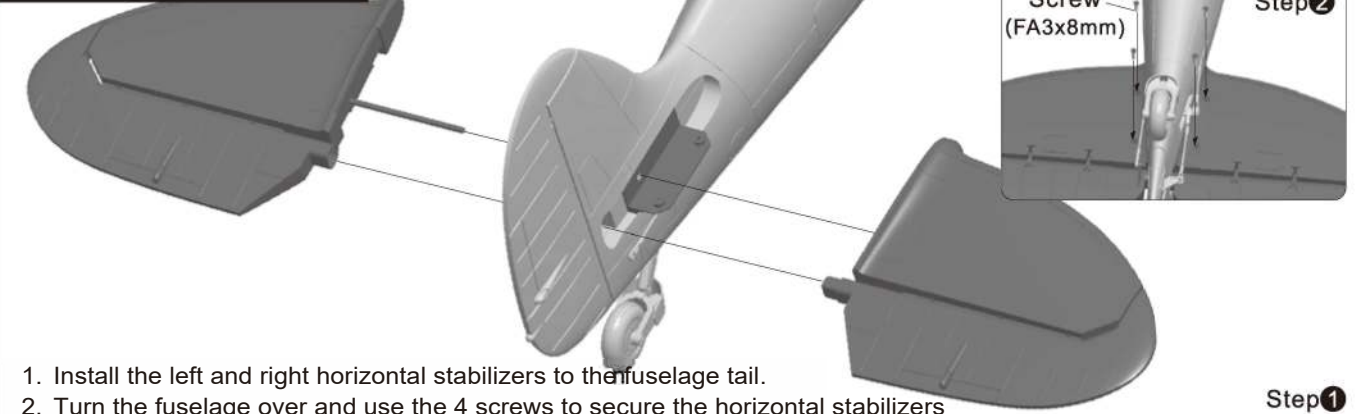

1. Install the left and right horizontal stabilizers to the fuselage tail.
2. Turn the fuselage over and use the 4 screws to secure the horizontal stabilizers

Elevator/Rudder pushrod Installation

1. Use a servo tester or radio to center the servo.
2. Use screws to attach the servo to the plastic board.
3. Run the servo cable from the plastic board to the battery compartment.

Note: If you choose not to use the factory servo, the servo you choose may be larger. If that's the case, you need to remove the fixed wooden platform and glue the servo to the servo position in the fuselage.

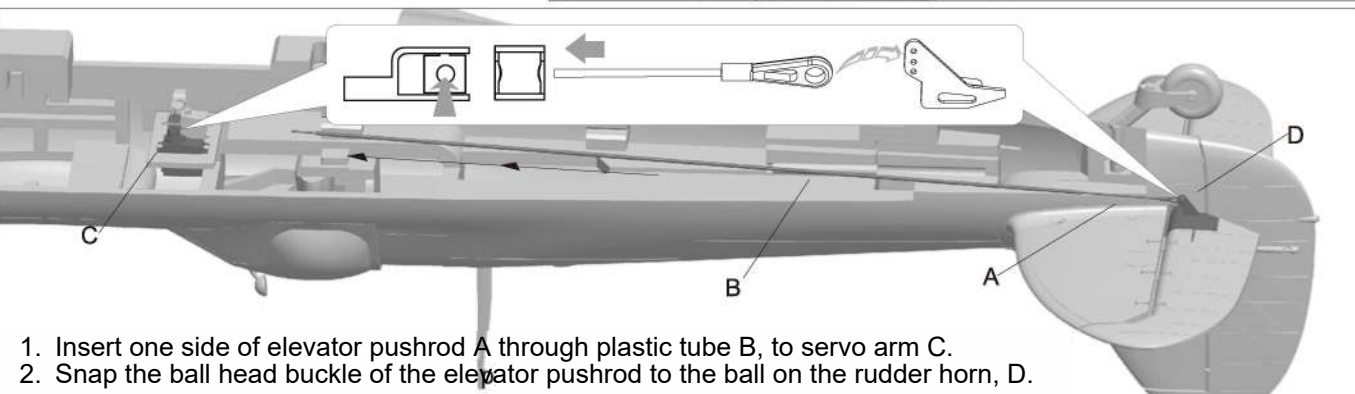
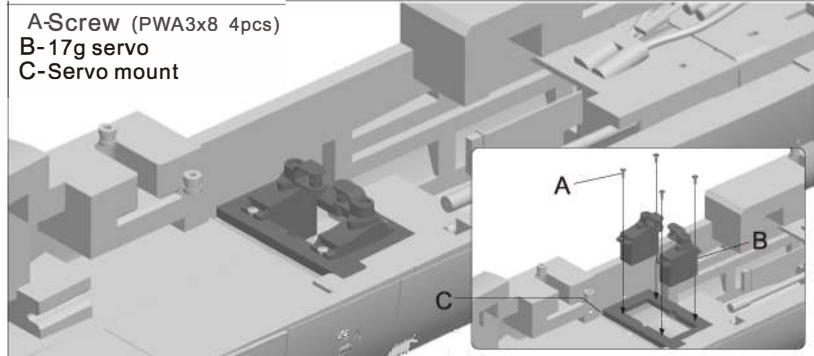

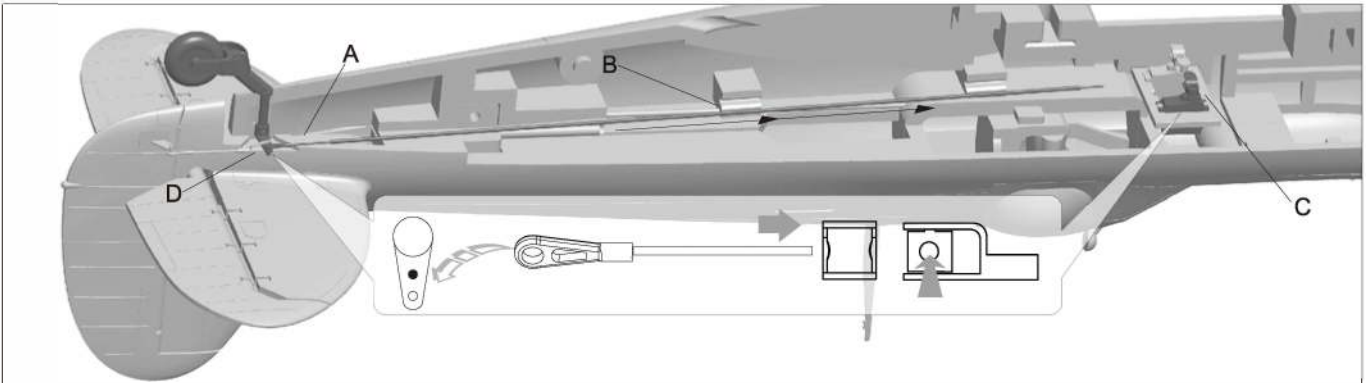

1. Insert one side of rudder pushrod A, through plastic tube B, to the servo arm C.
2. Buckle the ball head buckle of rudder pushrod to the rudder horn D.

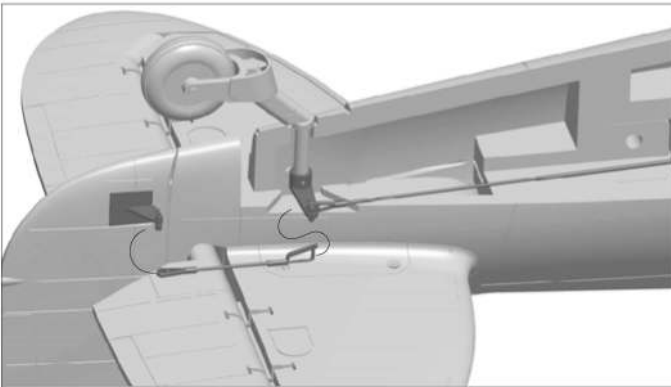

Note: When installing the rudder pushrod, make sure the tail wheel is centered. Then install the rudder pushrod, and adjust the plastic clevis to center the rudder.

1. Use rudder pushrod to connect the tail gear steering arm and rudder horn.

Aileron pushrod Installation

1. Use servo tester or radio to center the servo.
2. Use glue to attach the servo and aileron horn to the main wing.
3. Run the servo cable through the trough, after all the servos are installed, apply the decal over the trough.
4. One side push rod insert to the servo arm, adjust its length. And insert the Ball-head to the aileron horn.
5. Repeat these steps for the other main wing.

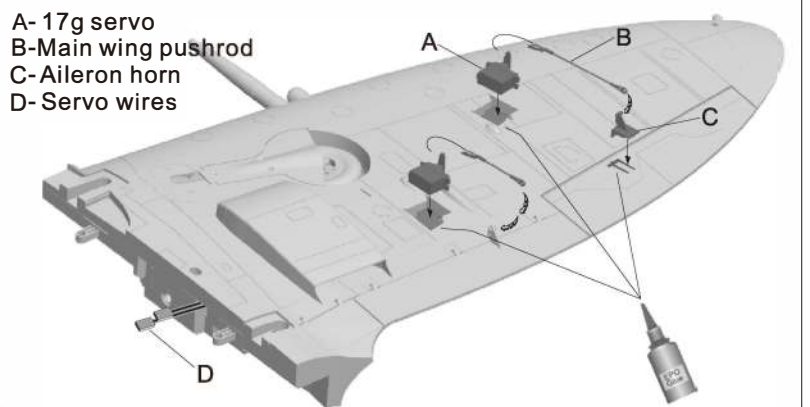

- A- 17g servo
- B- Main wing pushrod
- C- Aileron horn
- D- Servo wires

Main wing Installation

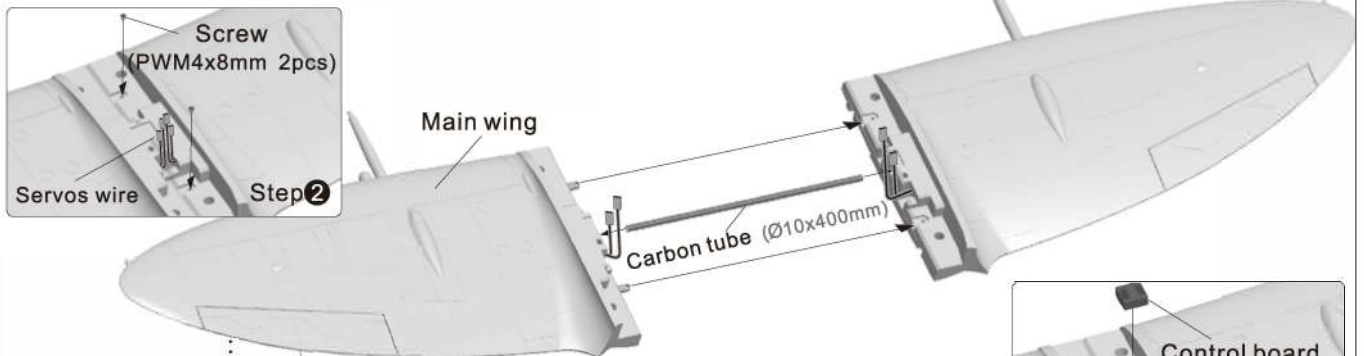

1. Insert the carbon tube into the main wing, and slide the left and right main wings together. Glue is not required.
2. Use the 2 machine screws to join the main wing.
3. Match the text on the label with the text on the control board, and attach it as shown in the photo.

- 5. Pull the main wing servo cables from the fuselage up into the battery compartment.
- 6. Insert the main wing plastic joiner pieces, A and B to the underside of the wing, as shown. Finally, use the four machine screws to attach the wing to the fuselage.

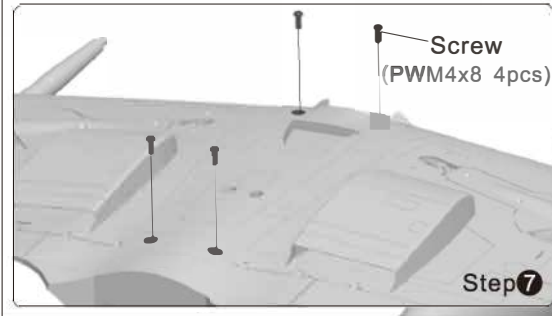
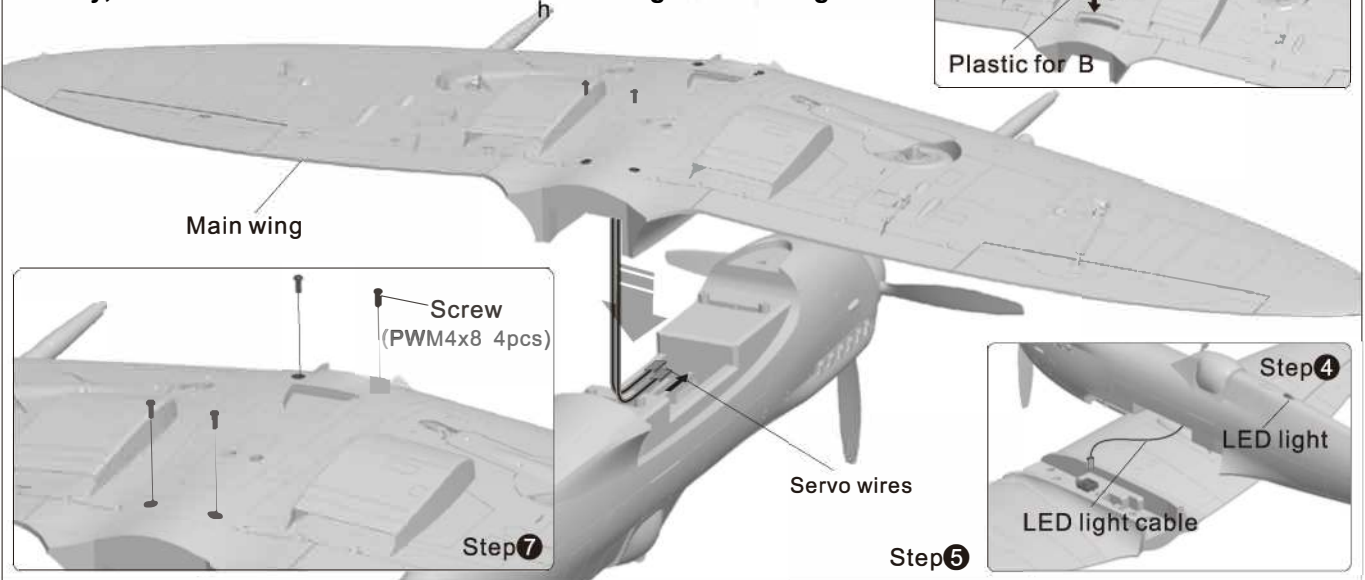
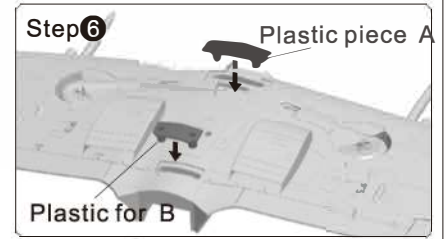

Pushrod instructions

Steering pushrod size	Steering pushrod mounting hole
<p>710mm (27-15/16")</p> <p>Pushrod diameter Ø1.5mm</p>	
Rudder pushrod size	Rudder pushrod mounting hole
<p>65mm (2-9/16")</p> <p>Pushrod diameter Ø1.5mm</p>	
Elevator pushrod size	Elevator pushrod mounting hole
<p>760mm (29-15/16")</p> <p>Pushrod diameter Ø1.5mm</p>	
Aileron pushrod size	Aileron pushrod mounting hole
<p>125mm (4-15/16")</p> <p>Pushrod diameter Ø1.5mm</p>	
Flap pushrod size	Flap pushrod mounting hole
<p>58mm (2-1/4")</p> <p>Pushrod diameter Ø1.5mm</p>	

Scale parts Installation

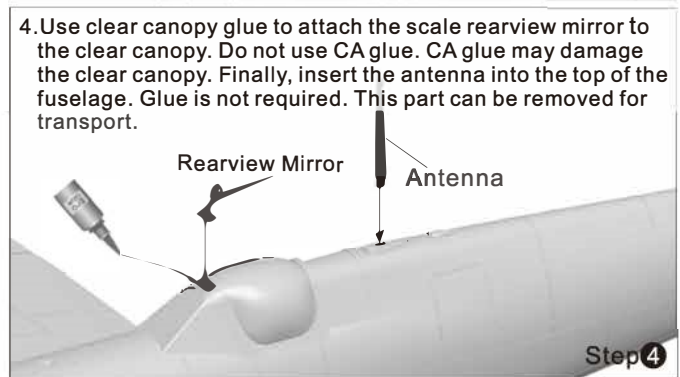
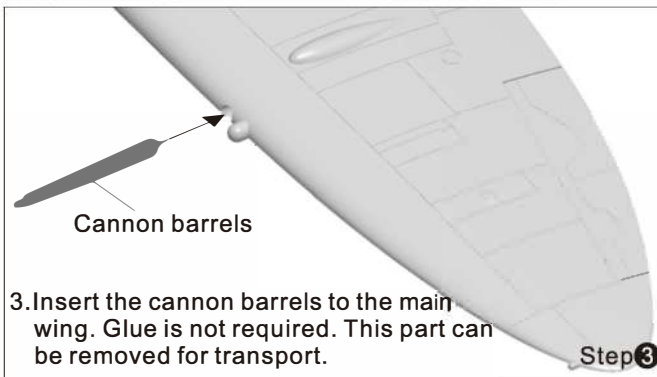
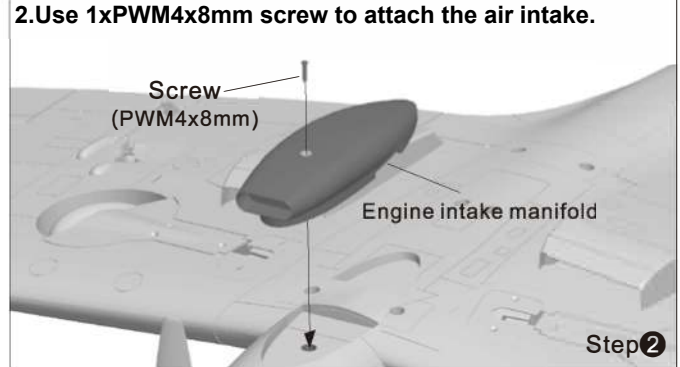
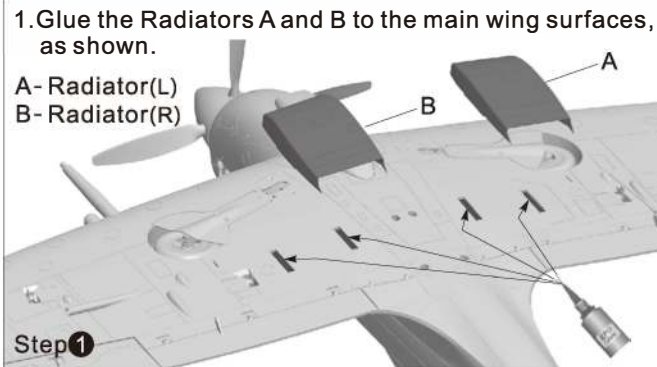

Note: After completing the above steps, depending on the model of your control board, insert the aileron, flap and landing gear cables to the control board.

Introduction to the Control board

Control board Instruction

Using the diagram as a guide, insert the landing gear, LED lights and flaps into the designated input plug. Then plug the Flap, L-G and Ail output plugs into the receiver. Rudder and elevator servos will plug directly into the receiver.

Control board functions:

1. Replaces Y-cables and other connection cables, allowing for a cleaner wiring job and better quality connections.
2. The board is an all-in-one control surface/LED light control board.

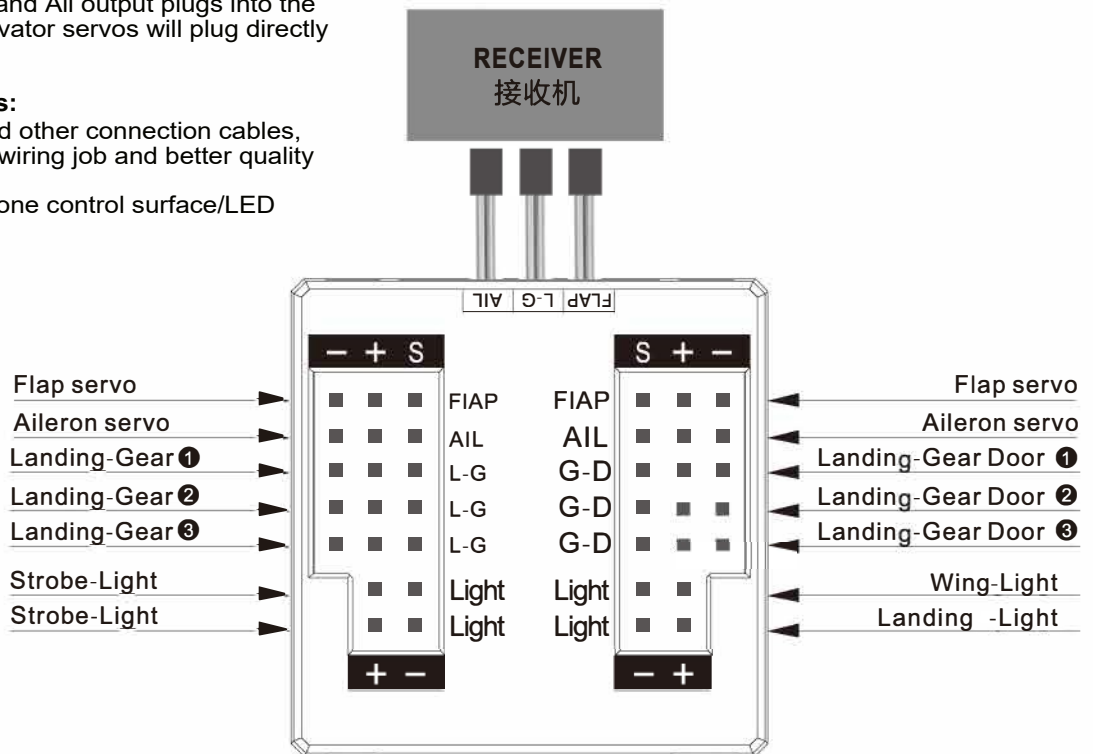

Battery Installation

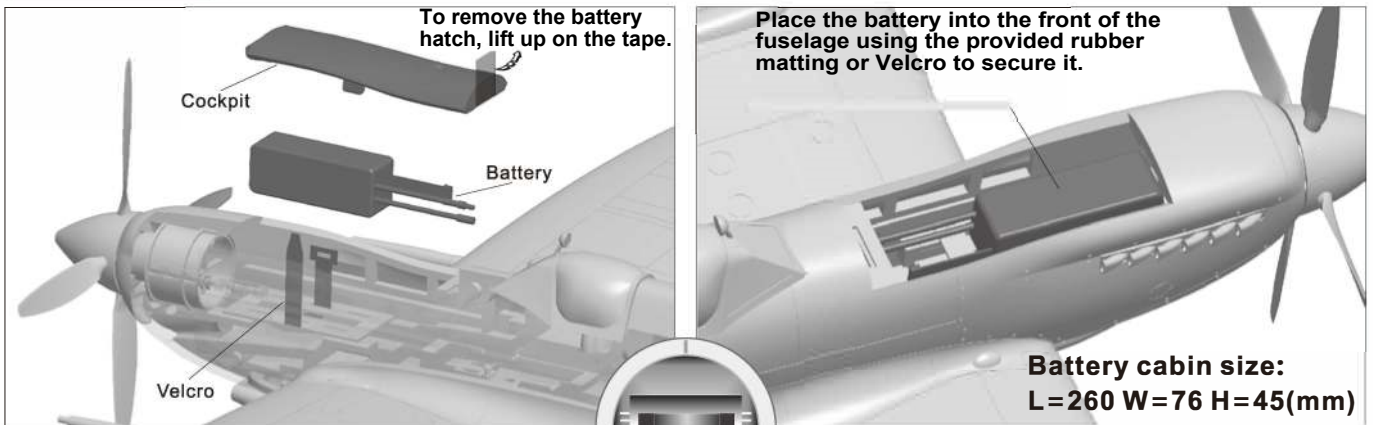

Before connecting the battery to the ESC, please remove the propeller.

Switch on the transmitter and ensure that the throttle is in the lowest position.

Once you have programmed your radio transmitter, ensure before all future flights there are no objects within the propeller diameter before plugging in the battery, to avoid accidents and personal injury.

The battery capacity and discharge rate we advise is :

6S 22.2V 3500mAh ~ 6S 22.2V 5000mAh
Discharge rate of C ≥ 30C

Center of gravity

Correct center of gravity is directly related to the success of any flight, please refer to the following CG diagram to adjust your plane's center of gravity.

You can move the battery forward or backward to adjust the center of gravity.

- If you can not adjust the CG by moving the battery, you can also use some other suitable material weight to counterweight, to make sure that CG is in the correct position.

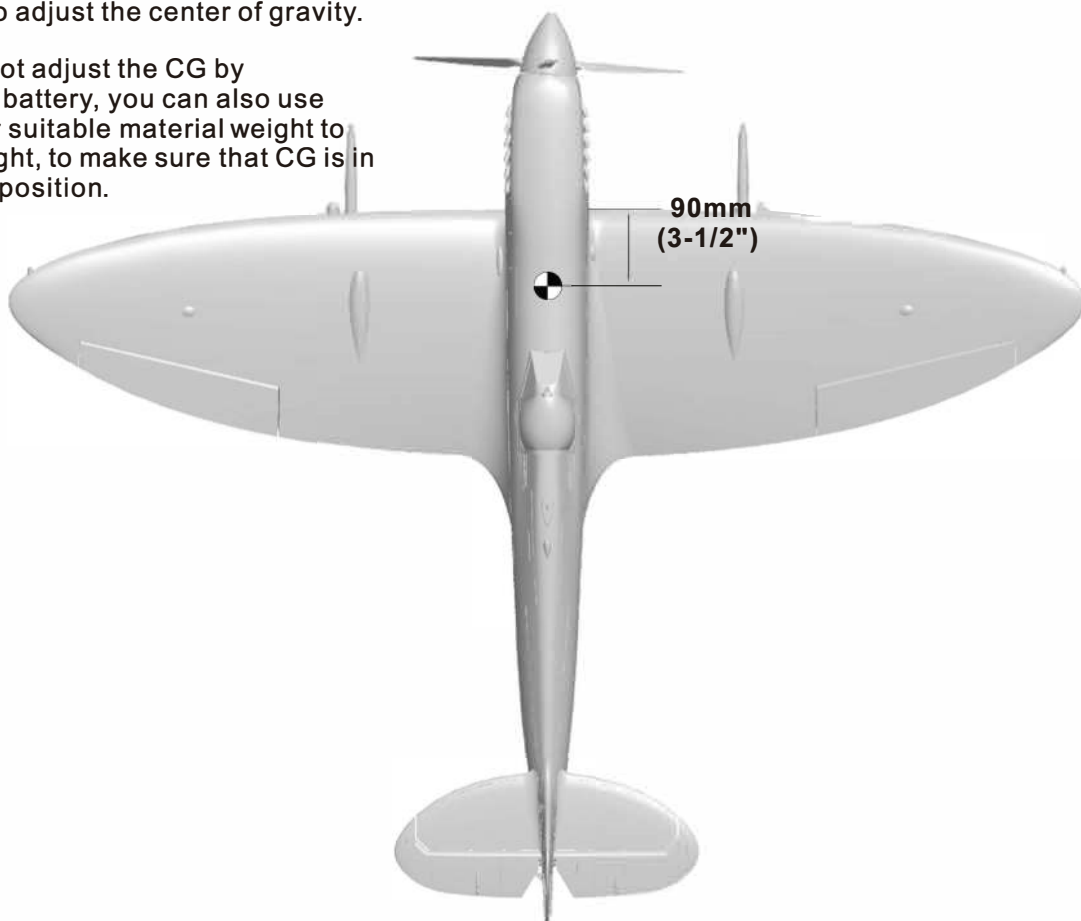

Control direction test

After installed the plane, before flying, we need a fully charged battery and connect to the ESC, then use radio to test and check that every control surface work properly.

Ailerons

Stick Left



Stick Right



Elevators

Stick Back



Stick Forward



Rudder

Stick Left



Stick Right



Flaps

Flaps down



Dual rates

According to our test results, the following rates proved to be a good starting point. Low rates are good for initial flights or for less experienced pilots. Adjust rates to suit your own style.

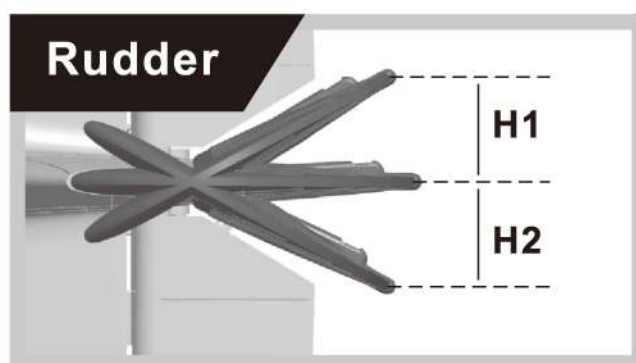
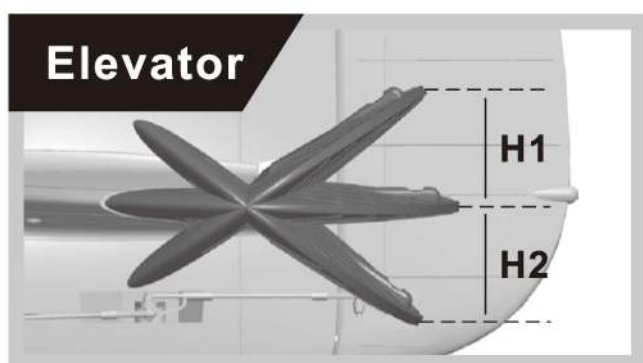
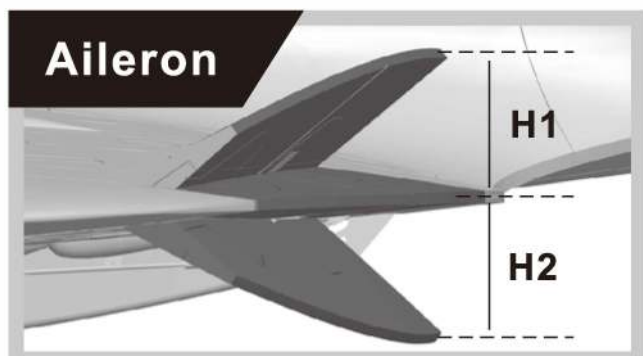

	Aileron(Is Side)	Elevator (Is Side)	Rudder (The Bottom)	Flaps
Low Rate	H1/H2 31mm/31mm D/R Rate : 80%	H1/H2 27mm/27mm D/R Rate : 75%	H1/H2 28mm/28mm D/R Rate : 80%	H1 24mm
High Rate	H1/H2 38mm/38mm D/R Rate : 100%	H1/H2 33mm/33mm D/R Rate : 100%	H1/H2 33mm/33mm D/R Rate : 100%	H1 40mm

- ⚠ Note Before Flight :**
- Depending on your flight battery and your personal preference for flight stability versus agility, trim the elevator 2mm up. This can be pre-set by either of the following two ways:
 - Use pushrod to keep 2mm elevator up.
 - Center the elevator, and set the 2mm elevator up in your radio.
 - When the flaps are deployed, the aircraft will nose slightly downward. In your radio transmitter, program a Down-Flap-to-Up-Elevator mix according to these parameters.
 - Flap travel down 24mm/ set elevator travel UP 1.5mm
 - Flap travel down 40mm/ set elevator travel UP 3mm

Servos Introductions

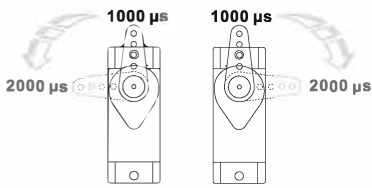

A servo or reversed servo is defined as follows:

When the servo input signal changes from 1000μs to 2000μs if the servo arm rotates clockwise it's a positive servo. If it rotates counter clockwise it's a reversed servo.

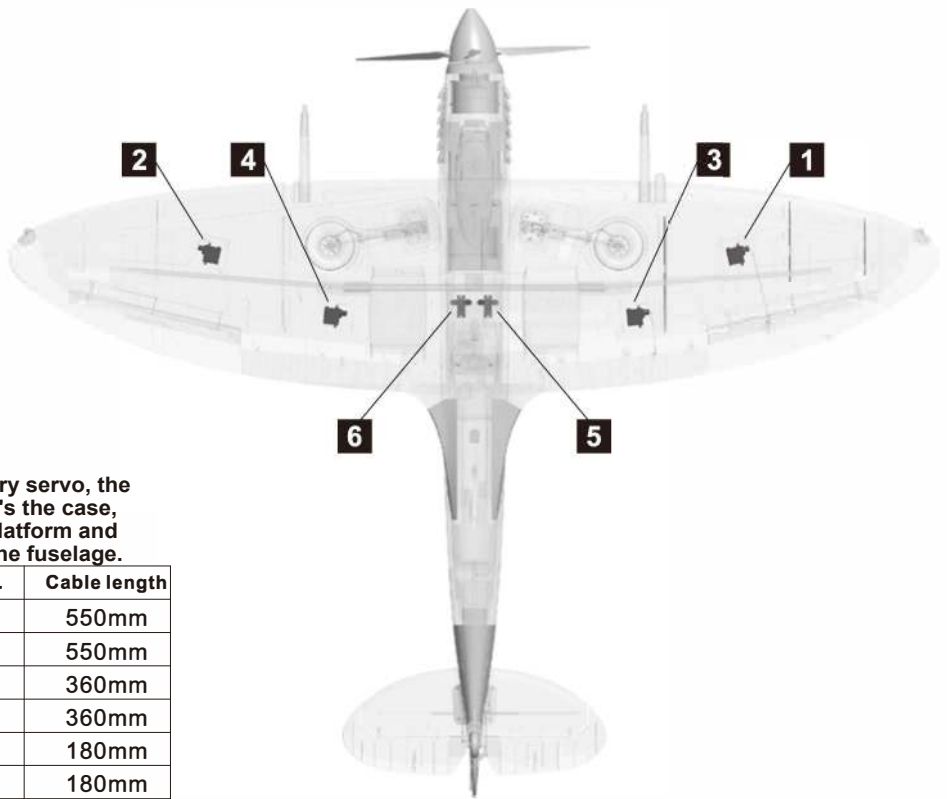

Note: If you choose not to use the factory servo, the servo you choose may be larger. If that's the case, you need to remove the fixed wooden platform and glue the servo to the servo position in the fuselage.

Position	Model	No.	Pos./Rev.	Cable length
Aileron(L)	17g Hybrid	1	Positive	550mm
Aileron(R)	17g Hybrid	2	Positive	550mm
Flap(L)	17g Hybrid	3	Positive	360mm
Flap(R)	17g Hybrid	4	Positive	360mm
Elevator	17g Hybrid	5	Positive	180mm
Rudder	17g Hybrid	6	Positive	180mm

Motor Parameters

Motor size

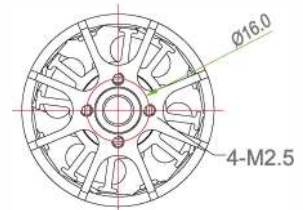
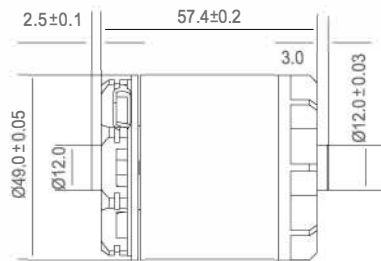
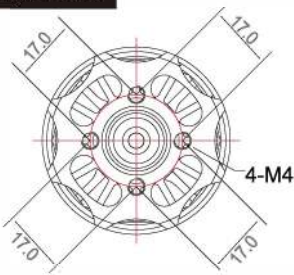

5055-390KV

Unit: mm

Item No.	KV Value	Volute (V)	Current (A)	Pull (g)	Motor Resistance	Weight (g)	No Load Current	Propeller	ESC
MO1505501	390RPM/V	22.2V	60	5600	0.02 Ω	410	2.3A/10V	4-Blade16×10	≥80A

Motor shaft, X-fixed base

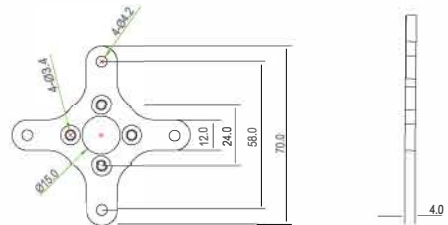
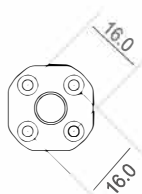
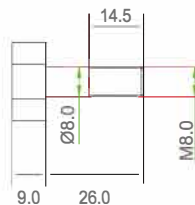
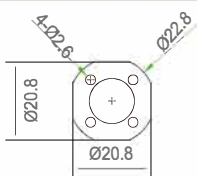

Unit: mm

Power system installation

- A- Screw (KM4x8mm 4pcs)
- B- Motor mount
- C- 5055-390KV out-runner motor
- D- Propeller hub
- E- Screw (HM2.5x10mm 4pcs)

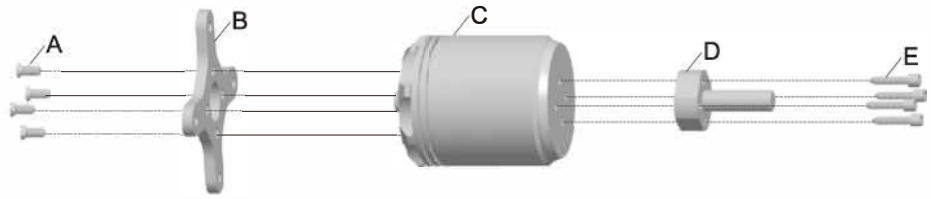

- A- Fire wall
- B- Screw (PA4x15mm 4pcs)
- C- Screw (PM3x16mm 8pcs)
- D- Scale propeller (16x10, 4-blade)
- E- Scale propeller back plate

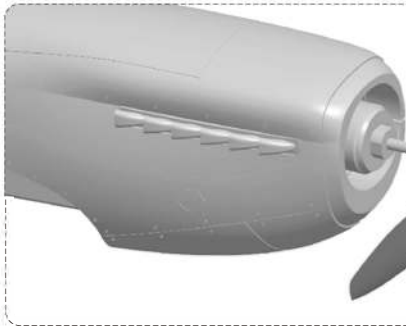
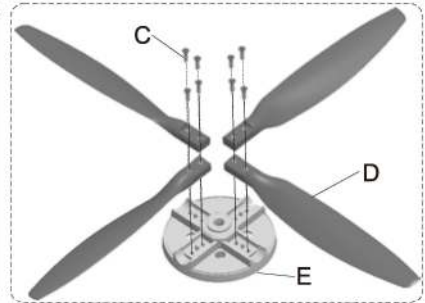
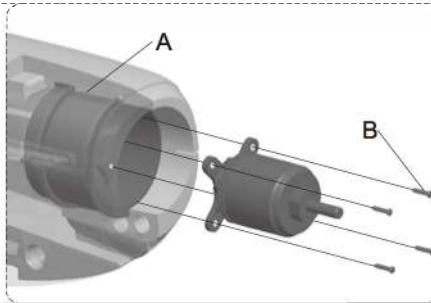

NOTE: As an upgrade for propeller strength, a metal reinforcement piece has been added, to be installed over the propeller blades. (Not shown in the diagram.)

- A- Spinner center plug
- B- Screw (PM3x30mm 1pcs)
- C- Spinner (scale 4-blade spinner)
- D- Propeller securing bolt
- E- Washer (Ø24.5x3xØ8.0mm)

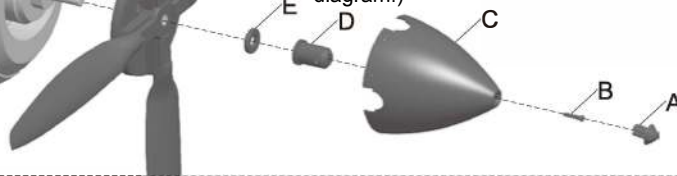

ESC Installation

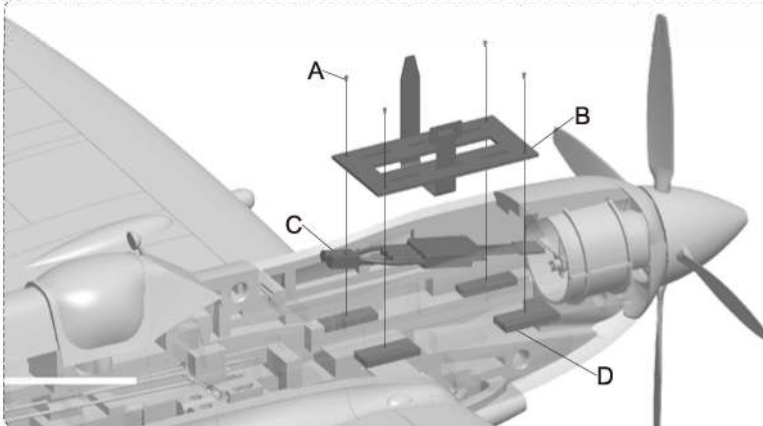

- A- Screws (FA3x8mm 4pcs)
- B- Battery tray
- C- ESC
- D- Tray holder

Put the ESC under the battery tray, there is a specially designed ventilation duct that will cool the electric equipment effectively.

Accessories Description

EN

Main landing gear installation

Assemble and disassemble the main landing gear according to the following photos.

- | | | |
|---|--|--------------------------------|
| A - Main gear axle | L - C-Buckle (Ø1.5mm) | W - Screw (PA1.4x12 2pcs) |
| B - Main wheel (ØB5x26mm) | M - C-Buckle (Ø1.5mm) | X - Main landing gear door |
| C - Grub Screw (M4x4) | N - C-Buckle (Ø1.5mm) | Y - Screw (KA2.3x8 2pcs) |
| Ø - Main gear strut | O - Spring | Z - Screw (FM2x7 1pcs) |
| E - Grub Screw (M4x3) | P - Nose gear shock absorber scissor arm | |
| F - Main gear shock absorber active rod | Q - Nose strut fixed ring | AB - Nose landing gear |
| G - Nose gear shock absorber arm fixed part | R - Screw (PM2x3 1pcs) | AC - Metal reinforcement plate |
| H - Screw (PM2x3 2pcs) | S - Nose gear strut | AD - Screw (KA3x12 4pcs) |
| I - Pin (Ø3.5x12.6mm 1pcs) | T - X Set screw (M3x5.2 2pcs) | AE - Landing gear cover |
| J - Pin (Ø2x13.1mm 1pcs) | U - IMI Screw (M4x4) | AF - Screw (KA2.3x8 2pcs) |
| K - Pin (Ø3.5x7.3mm 1pcs) | V - Screw (PA1.6x10 4pcs) | |

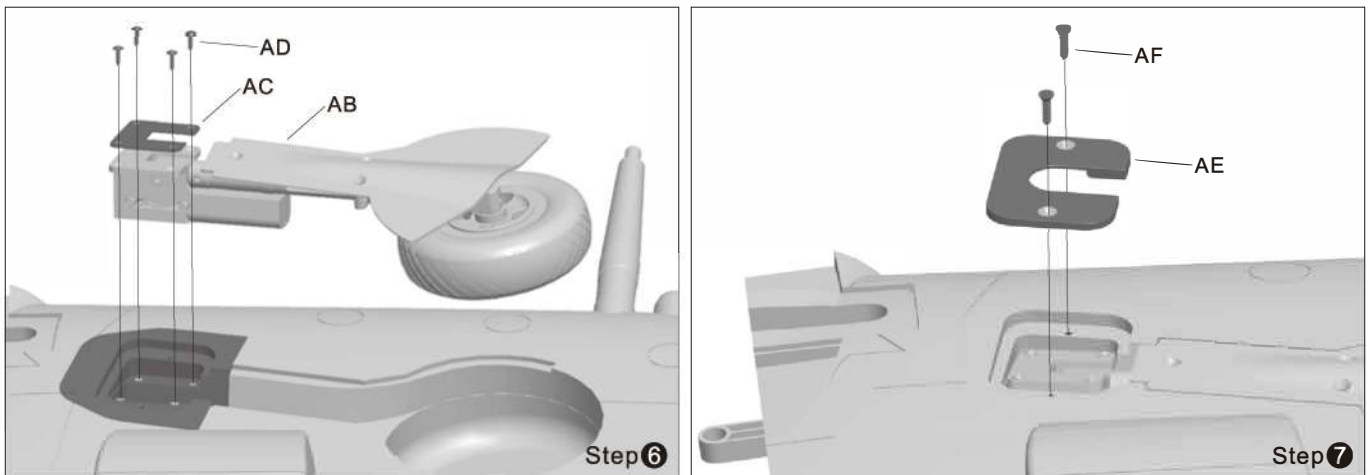
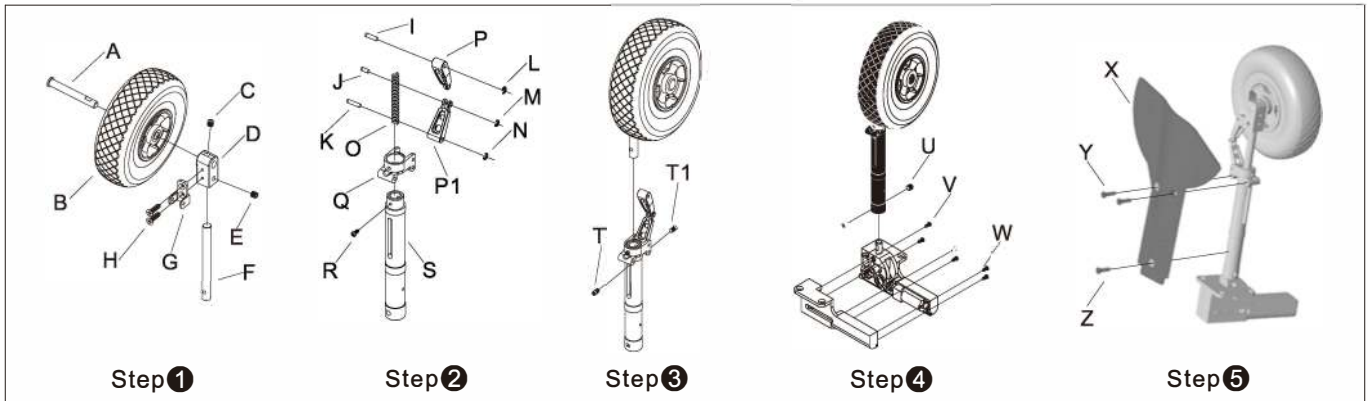

Rear landing gear installation

1. Referring to the diagram, install the tail wheel assembly.
2. Insert the tail wheel axle part C to the tail wheel strut part B, then through the tail wheel to the other side of the strut.
3. Use C clip D to secure the axle.

- | |
|-----------------------------|
| A - Rear wheel (Ø45x16mm) |
| B - Rear Strut |
| C - Rear wheel shaft |
| D - C clip (Ø5xØ2mm) |
| E - Rear axle fairing |
| F - Tail wheel steering arm |
| G - Tail wheel hard point |
| H - Tail wheel assembly |
| I - Screw (PA1.6x6mm) |

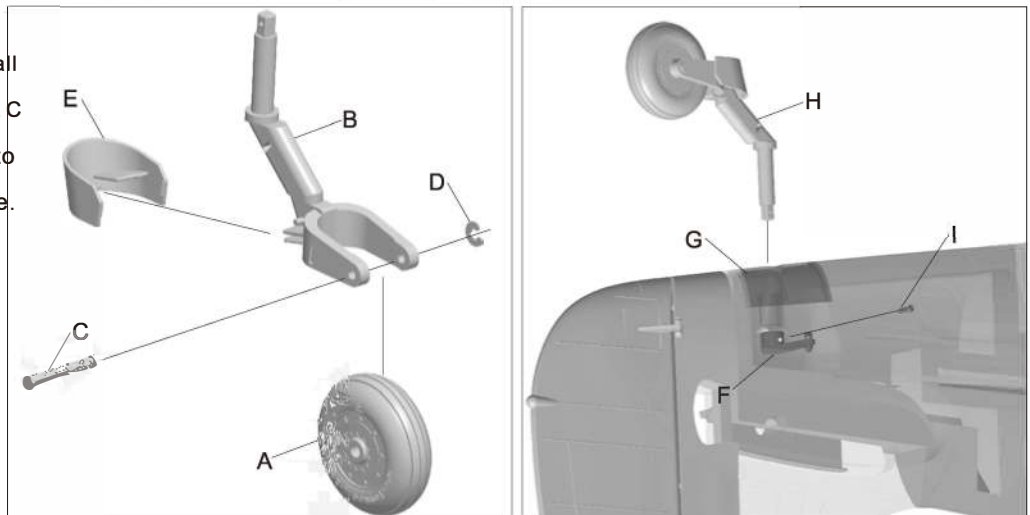



Dongguan Freewing Electronic Technology Ltd
HK Freewing Model International Limited

Add.: Fei Yi Building, face to Labor Bureau, Fumin Middle Road, Dalang Town,
Dongguan City, Guangdong Province, China

Web: <http://www.sz-freewing.com>

Email: freewing@sz-freewing.com

Tel: 86-769-82669669 Fax: 86-769-82033233

东莞市飞翼电子科技有限公司
香港飞翼模型国际有限公司

地址: 广东省东莞市大朗镇富民中路402-408号飞翼楼四楼

Web: <http://www.sz-freewing.com>

Email: freewing@sz-freewing.com

Tel: 86-769-82669669 Fax: 86-769-82033233

