

# SUKHOI SU-26



## INSTRUCTIONS

When it was introduced, the outstanding Russian **SUKHOI** took the aerobatic world by storm! Never before have aerobatic enthusiasts had a machine so capable that it appears to have no limits. It enables the pilot not only to execute maneuvers with exceptional precision, but allows him to invent new maneuvers, as well! We have so completely captured the essence of this extraordinary, competition-worthy aircraft that any good sport flyer will be able to experience the thrill of true unlimited aerobatics with his GOLDBERG SUKHOI. **IMPORTANT:** When selecting a power plant for your SU-26, do not put in a larger-than-recommended engine. This will cause undue stress to the airframe and may result in structural failure. Remember, a bigger engine does not necessarily mean better performance.

### **WARNING! THIS IS NOT A TOY!**

A radio-controlled model is not a toy and is not intended for persons under 16 years old. Keep this kit out of the reach of younger children, as it contains parts that could be dangerous. A radio-controlled model is capable of causing serious bodily injury and property damage. It is the buyer's responsibility to build this kit correctly and to properly install the motor, radio, and all other equipment. Test and fly the finished model only in the presence and with the assistance of another experienced R/C flyer. The model must always be operated and flown using great care and common sense, as well as in accordance with the safety standards of the Academy of Model Aeronautics (5151 Memorial Drive, Muncie, IN 47302, 1-800-435-9262). We suggest you join the AMA and become properly insured prior to flying this model. Also, consult with the AMA or your local hobby dealer to find an experienced instructor in your area. Per the Federal Communications Commission, you are required to use only those radio frequencies specified "for Model Aircraft."

#### **LIMITED WARRANTY**

Carl Goldberg Products takes pride in the care and attention given to the manufacture of components for its model airplane kits. The company warrants replacement of any materials found to be defective for their intended use, prior to their use in construction of the aircraft, provided the buyer requests such replacement within one year from the date of purchase and provided the defective part is returned, if so requested by the company.

No other warranty, expressed or implied, is made by the company with respect to this kit. The buyer acknowledges and understands that it is his responsibility to carefully construct a finished flying model airplane and to fly it safely. The buyer hereby assumes full responsibility for the risk and all liability for personal or property damage or injury arising out of the buyer's use of the components of this kit.

## ITEMS NEEDED TO COMPLETE THIS KIT

- 1 RADIO GUIDANCE SYSTEM (4 CHANNEL MINIMUM REQUIRED)
- 1 ENGINE .90 2-CYCLE OR 1.20 4-CYCLE (NO BIGGER!)
- 1 PROPELLER (SIZE DEPENDS ON ENGINE)
- 1 12-16 OZ. FUEL TANK
- 1 12" SILICONE FUEL LINE
- 2 3-1/2" DIAMETER WHEELS
- 1 1-1/4" DIAMETER WHEEL
- 3 ROLLS IRON ON COVERING FLIM
- 1 CGP 3" DIAMETER SPINNER
- 3 2 OZ. BOTTLE CA GLUE
- 1 EPOXY 6 OR EPOXY 20 MINUTE
- 1 TUB JET MODEL MATE
- 1 CGP 1/4" FOAM PADDING
- 4 CGP 3/16" WHEEL COLLAR
- 1 TUBE CLEAR CANOPY GLUE
- 1 CGP 3/32" WHEEL COLLAR

### OPTIONAL

PILOT: 1/5 SCALE

## TOOLS AND SUPPLIES REQUIRED FOR ASSEMBLY

- MISCELLANEOUS RUBBER BANDS (INCLUDING #64)
- ROLL OF WAXED PAPER
- SANDPAPER (ASSORTED GRITS, INCLUDING COARSE (80), MEDIUM (150) AND FINE (220))
- SANDING BLOCK
- "T" PINS (at least 100)
- X-ACTO MODELING KNIFE
- SINGLE EDGE RAZOR BLADE
- RAZOR SAW
- BUILDING BOARD (24" x 74")
- 36" STEEL STRAIGHT EDGE
- ELECTRIC DRILL
- 1/8" DRILL BIT
- 5/16" DRILL BIT
- 5/32" DRILL BIT
- SMALL SCREWDRIVER
- SOLDERING IRON AND FLUX
- COVERING IRON AND HEAT GUN
- MASKING TAPE
- 6" RULER
- 10" 30-60-90 DRAFTING TRIANGLE
- SPRAY BOTTLE

# INTRODUCTION

## USING THIS INSTRUCTION MANUAL

Before you start gluing and sanding, take some time becoming familiar with the plans and looking through this entire Instruction Booklet. It is designed to guide you through the construction process step by step, so build in the order given in this book. Building options, as well as balancing, set-up, and flying the model are covered.

Like a full-size airplane, the **SUKHOI** is built from basic structures (stabilizer, fin, wing, etc.), which are then assembled into the complete airplane.

Special procedures or comments will usually be explained before a step, so you will be prepared. If a step begins with a statement like "Note," "Warning," or "Important," it is a good idea to read through the step before doing it.

A check-off box appears at the beginning of each step. Check these boxes as you build, so you can tell at a glance what steps you have completed. Some steps are repeated and must be marked twice, as in the case of the left and right wing panel.

Some of the instructions deal with general procedures. Boxes are not needed for these sections.

## HOW TO READ THE PLAN

There are two plan sheets in this kit, showing the Fuselage (Body), the Wing, and the Tail Parts. Everything on the plan is drawn to full-size and shape and shows how the finished parts fit together.

The plan is drawn to show the model completely assembled, but as a result, the areas inside or underneath are covered up, making it hard to understand how these parts fit together. Therefore, for clarity, some parts are drawn with hidden lines, others with breakaway views, and some are entirely removed from the structure and shown separately.

For example, on the fuselage, the left side of the completed model has been removed to show the details inside. Sometimes a surface is broken away to reveal the detail behind or underneath. Dashed lines indicate details that are hidden behind or under another part of the surface.

The model is made from four varieties of wood: balsa, bass, birch, and various plywoods. Each kind of wood has its own characteristic end grain pattern (as viewed from the end) which has been drawn in this book. You can easily use these end grain patterns to identify what kind of wood is shown for a part, if you are in doubt.

## HOW TO USE THE PLAN

The plan is used in several ways. The wings, stabilizer, and fin are assembled directly over the plan. Each wood part is matched over its corresponding location printed on the plan and pinned in place. To prevent ruining your plan from gluing your wings, etc. to it, cover the area you are working on with waxed paper.

**The paper the plan is printed on can expand or contract slightly with changes in temperature or humidity. Because of this, a preformed part such as the notched wing trailing edge may not exactly match the plan.** This is no problem, as slight deviations in the outline or size will not noticeably affect flight performance.

Because the fuselage plugs together and is self-aligning, it is not built directly over the plan. As you assemble the fuselage, you will find the plan helpful in identifying parts and how things fit together. The plan also shows the installation of a typical radio, battery and all remaining equipment and hardware needed to complete the model. By referring to the examples shown, you should be able to install your own radio, etc., even if it is not the same as what is shown on the plan.

## IDENTIFYING PARTS

Parts for the wing are bundled together; likewise, parts for the tail assembly are also grouped. Die-cut plywood and balsa sheets of common sizes are bundled together, so they are less likely to be damaged during shipping and handling.

The various screws, hinges, and fittings are packaged in plastic bags.

## PREPARING FOR ASSEMBLY

Set a flat, warp-free pinning board on your work bench. Any material that accepts pins, such as insulation board, soft plywood, or dry-wall (sheet rock) will work. Important: any warps or bends in the pinning board will result in wings or tail surfaces that are also warped or bent, making your model more difficult to fly. Make sure that the pinning board is flat by laying a straight edge across it. You may be able to correct a warped board by shimming its low areas.

Position the area of the plan (such as the stabilizer) on which you are going to build over the pinning board and tape it in place so the plan lays flat and wrinkle free.

Place a sheet of waxed paper or plastic kitchen wrap over the work area to prevent Super Jet from sticking to your plan and ruining it.

## CONSTRUCTION TIPS

In assembling your model, the following tips will prove helpful.

**IMPORTANT: ALWAYS READ A FEW STEPS AHEAD.** This will alert you to coming instructions and will help you plan accordingly.

You may find it convenient to empty all of the small parts from the hardware bags into a common container, such as a margarine tub. This will help you find items quickly.

When drilling any 1/16" holes in balsa, you may find it easier to twist the drill between your thumb and index finger. This procedure allows more control in positioning the drill on the center mark.

Punch out only the laser-cut parts you need as you proceed. This will help you keep track of parts, especially the small ones.

Sometimes you will be asked to "tack cement" a piece of wood that will later be taken apart. To provide for easy removal without damage, use only a small drop of glue.

After completing each section of the aircraft, you may want to go back and reglue the joints, just in case some area has been missed. Be careful not to use too little glue, which will leave the model weak, or too much glue, which can make the model heavy. Properly glued joints are important to the overall strength of the model. CA glue is recommended for most parts of the assembly, although epoxy glue may be used when more time is needed for careful placement.

## WOOD PARTS

Be careful when removing parts (such as fuselage formers) from the laser-cut sheets. Long parts are fragile until glued into a structural unit. If necessary, use a razor knife or razor saw to assist in the removal of parts from the sheet. Sometimes a little trimming and sanding can improve parts, where desired. Save scrap until the model is completed, in case a part is missing or damaged. Also, scrap is used in some building steps.

## ABOUT THE WOOD IN THE KIT

We strive to supply good quality materials in your kit. Wood parts are inspected with regard to the function they will serve. If an imperfection is spotted in a scrap corner of a laser-cut sheet and doesn't affect actual parts, the sheet is considered acceptable. Also, internal stresses in wood are relieved as it is cut into parts. These relieved stresses may cause some parts to bow. Bows in wood parts (such as leading edges) readily straighten out as they are CA glued into a structural unit

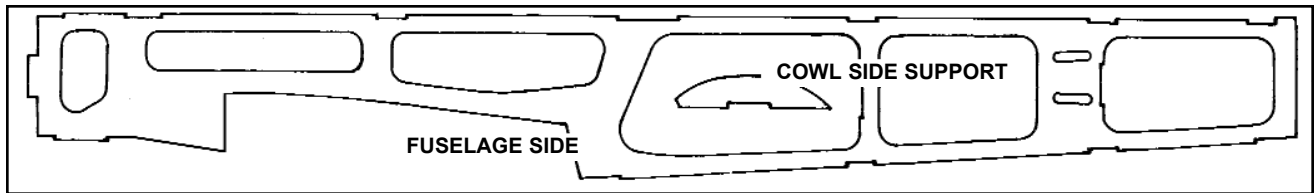

D/C SHT. 6728 2 REQ'D

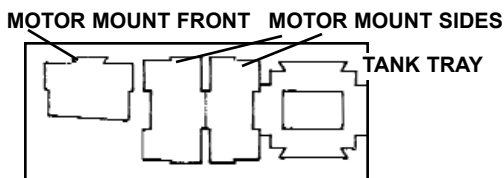

D/C SHT. 6705 1 REQ'D

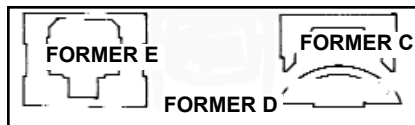

D/C SHT. 6703 1 REQ'D

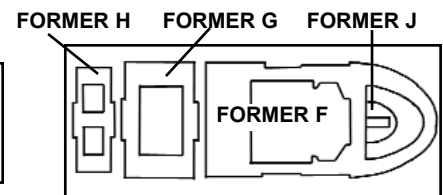

D/C SHT. 6704 1 REQ'D

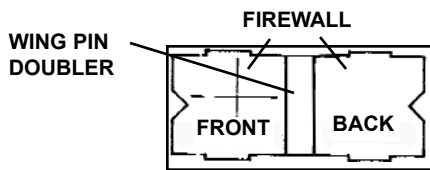

D/C SHT. 6706 1 REQ'D

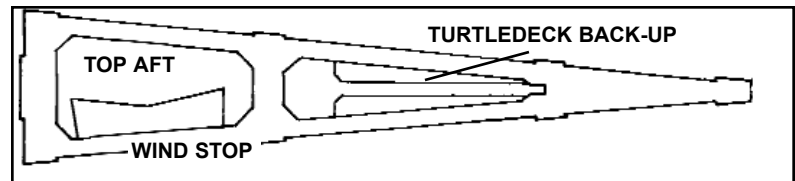

D/C SHT. 6707 1 REQ'D

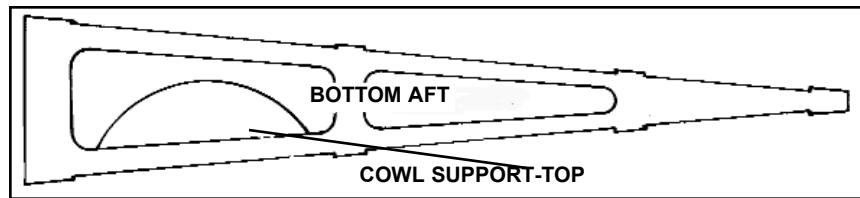

D/C SHT. 6708 1 REQ'D

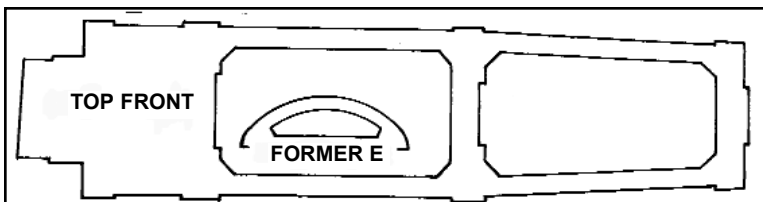

D/C SHT. 6709 1 REQ'D

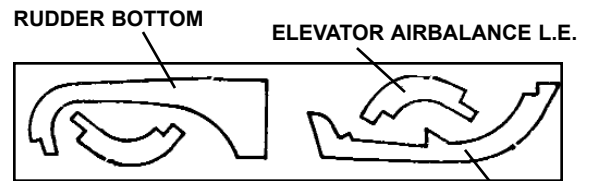

D/C SHT. 6711 2 REQ'D

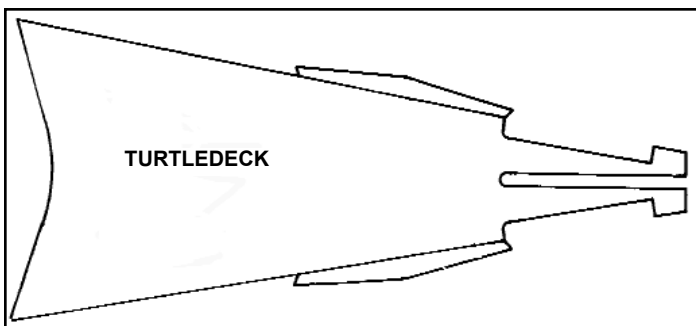

D/C SHT. 6710 1 REQ'D

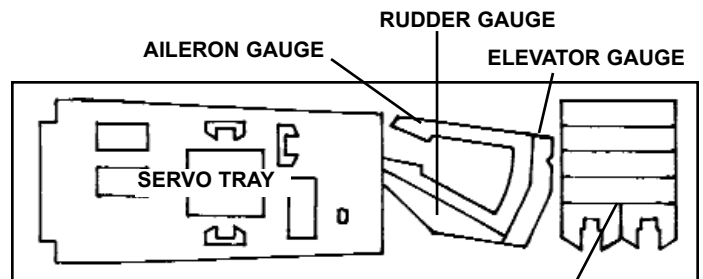

D/C SHT. 6712 1 REQ'D

ROUNDING TOOL PARTS

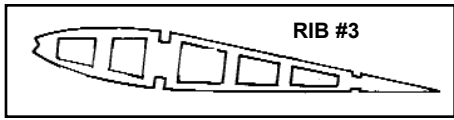

D/C SHT. 6725 2 REQ'D

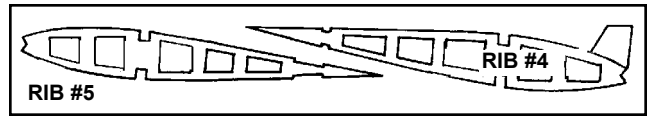

D/C SHT. 6714 2 REQ'D

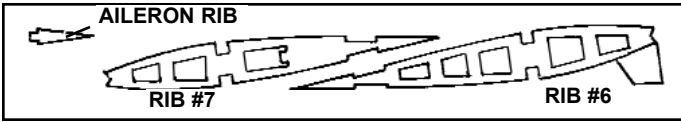

D/C SHT. 6715 2 REQ'D

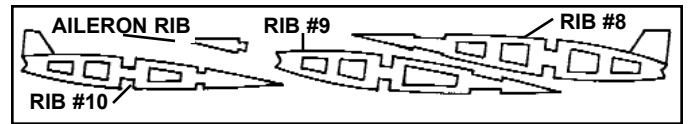

D/C SHT. 6716 2 REQ'D

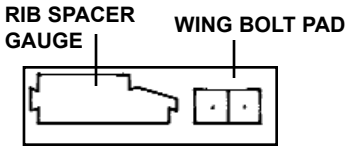

D/C SHT. 6726 1 REQ'D



D/C SHT. 6718 2 REQ'D

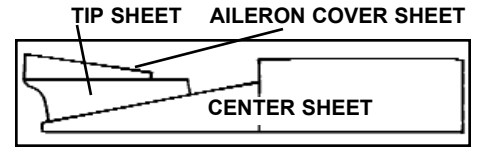

D/C SHT. 6719 4 REQ'D

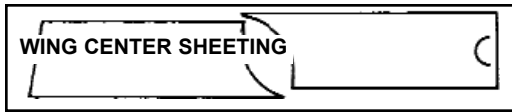

D/C SHT. 6720 4 REQ'D

ELEVATOR HORN MOUNT

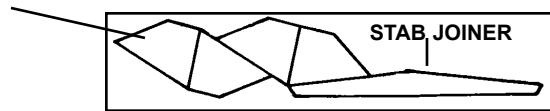

D/C SHT. 6727 1 REQ'D

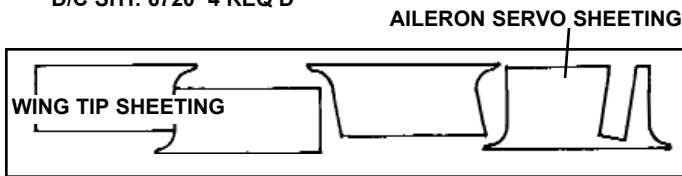

D/C SHT. 6722 2 REQ'D

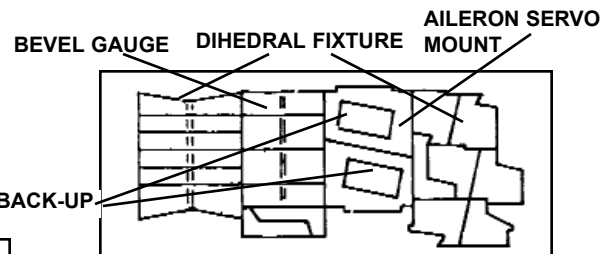

D/C SHT. 6723 1 REQ'D

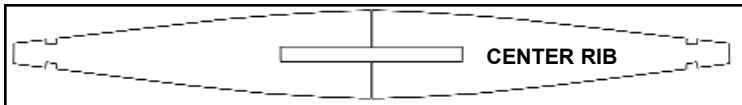

L/C SHT. 6730 1 REQ'D

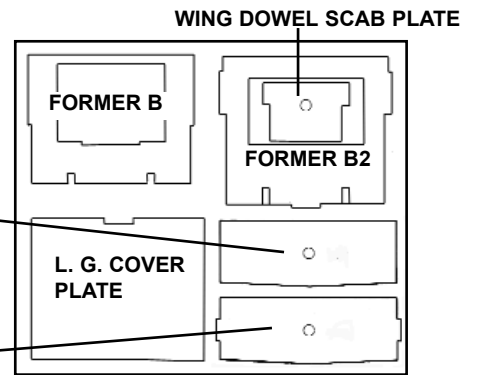

L/C SHT. 6732 1 REQ'D

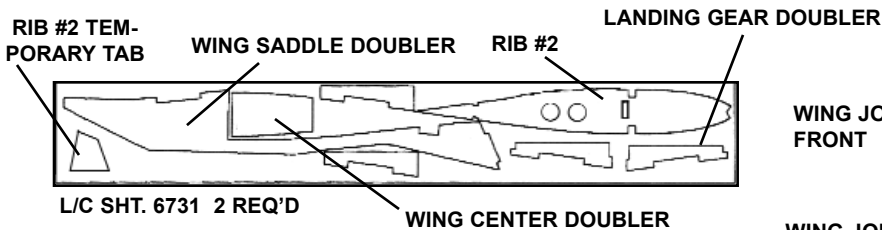

L/C SHT. 6731 2 REQ'D



1/2" Balsa TRI STOCK 3 REQ'D



3/16 x 3/8 x 20" Balsa 2 REQ'D



1/8 x 3/8 x 12" Balsa 4 REQ'D



3/8 SQ. BASS  
12" 8 REQ'D  
15" 1 REQ'D  
18" 4 REQ'D  
35-1/8" 4 REQ'D



SHAPED L.E. x 36" 2 REQ'D



5/16 x 3/8 x 14" Balsa 1 REQ'D



5/64 x 1/4 x 22" Balsa 5 REQ'D



5/16 DIA. x 4-1/2" DOWEL 1 REQ'D



1/4 x 5/16 Balsa  
12" 1 REQ'D  
16" 2 REQ'D  
24" 3 REQ'D



1/8 x 1/4 Balsa  
20" 3 REQ'D  
36" 4 REQ'D

# TAIL CONSTRUCTION

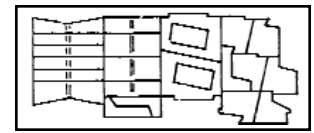
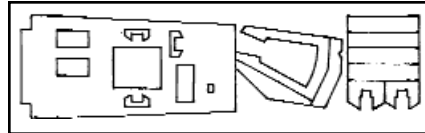
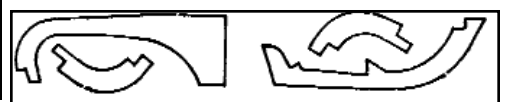
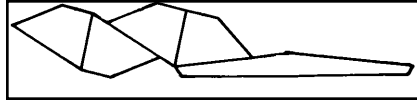
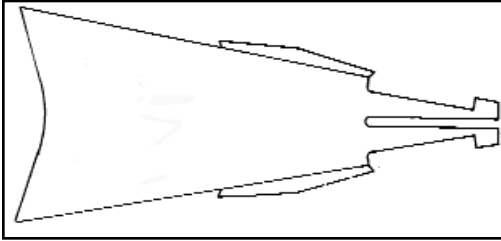

1. Collect the following items:
  - (1) D/C SHT. 6711 Balsa CONTAINS:
    - (4) ELEVATOR AIR BALANCE L.E.
    - (2) RUDDER BOTTOM
    - (2) RUDDER TOP
 PT. # 3670
  - (1) D/C SHT. 6712 PLY CONTAINS ROUNDING TOOL PT. #3671
  - (1) D/C SHT. 6727 Balsa CONTAINS:
    - (1) STAB JOINER
    - (4) ELEVATOR HORN MOUNT
 PT. #3657
  - (1) D/C SHT. 6723 PLY CONTAINS BEVEL TOOL PT. #3697
  - (1) D/C SHT. 6710 PLY CONTAINS:
    - (2) STAB JOINER DOUBLER
 PT. #3669
  - (3) TRUSSING STICKS 1/4 x 1/8 x 20" Balsa PT. #3675
  - (4) RUDDER TRUSSING 1/8 x 3/8 x 12" Balsa PT. #3676
  - (1) STAB T.E. DOUBLER 1/4 x 5/16 x 12" Balsa PT. #3677
  - (2) STAB L.E. & TIP 1/4 x 5/16 x 16" Balsa PT. #3678
  - (3) PERIMETER STICKS 1/4 x 5/16 x 24" Balsa PT. #3679
  - (2) ELEVATOR TRUSSING 3/16 x 3/8 x 20" Balsa PT. #3680
  - (1) RUDDER TRAILING EDGE 5/16 x 3/8 x 20" Balsa PT. #3681
  - (8) ELEVATOR PERIMETER STICK 3/8" SQ. x 12" Balsa PT. #3682
  - (1) RUDDER LEADING EDGE 3/8" SQ. x 18" Balsa PT. #3683
  - (1) STAB PLATFORM 1/4 x 2-1/2 x 3-3/4" Balsa PT. #3684
  - (4) STAB/FIN SHEETING 5/64 x 3 x 24" Balsa PT. #3685
  - (2) FIN SHEETING 5/64 x 3 x 18" Balsa PT. #3686
  - (1) CENTERLINE MARKING TOOL PT. #1425

- (10) LARGE FLEX POINT HINGE PT. #1449
- (1) WING PLAN PT. #2124
- (1) FUSELAGE PLAN PT. #2123

## HORIZONTAL STABILIZER

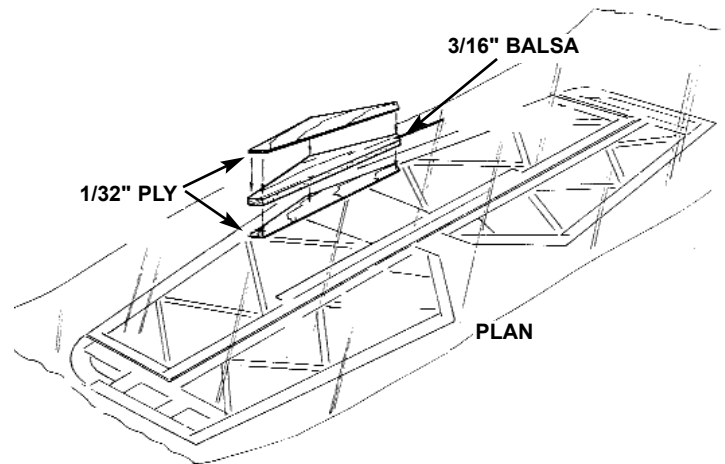

2.  Place the WING PLAN on the building board and cover the horizontal stabilizer portion of the plan with waxed paper.
3.  Glue a STAB JOINER DOUBLERS to each side of the STAB JOINER, as shown above.

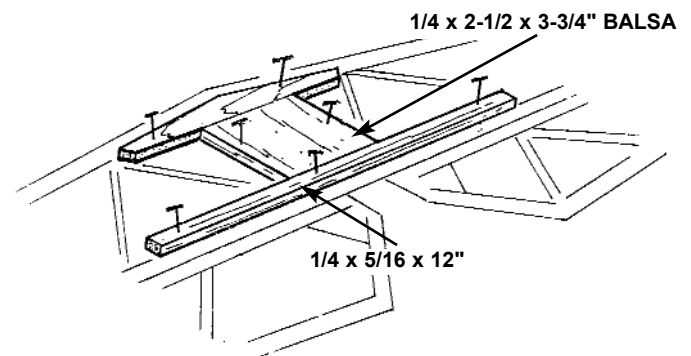

4.  Glue and pin the JOINER ASSEMBLY, STAB PLATFORM and T.E. DOUBLER over the plan.

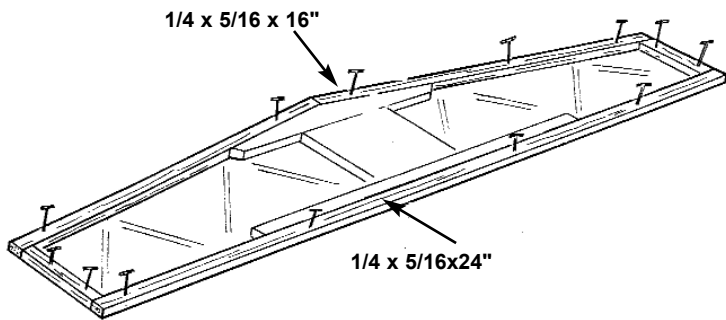

5.  Trim the STAB LEADING EDGES and TIPS to fit.
- Pin in place and glue.

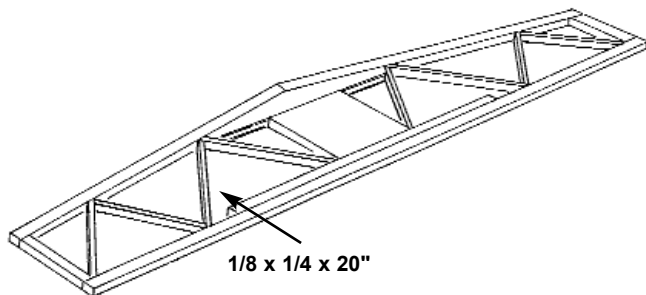

6.  Trim and glue the TRUSSING in place.

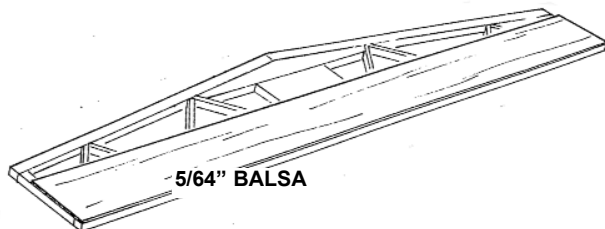

7.  Trimming as needed, prefit the SHEETING onto the stab. When satisfied with the fit, CA glue in place.

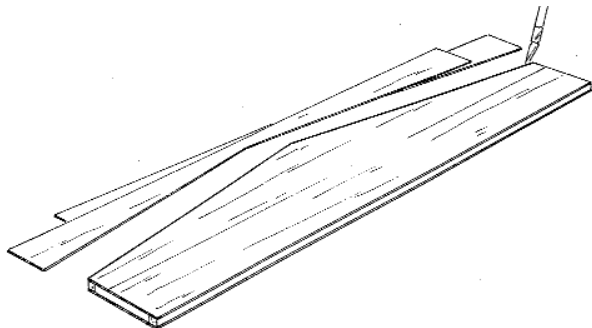

8.  Flip the stab over and sheet the other side.

## ELEVATOR

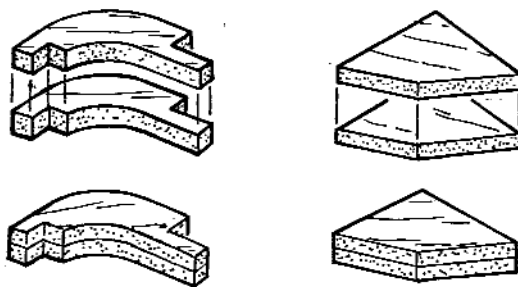

1.  Laminate the two sets of ELEVATOR AIR BALANCE L.E.s and ELEVATOR HORN MOUNTS.
2.  Place waxed paper over the elevator portion of the plan.

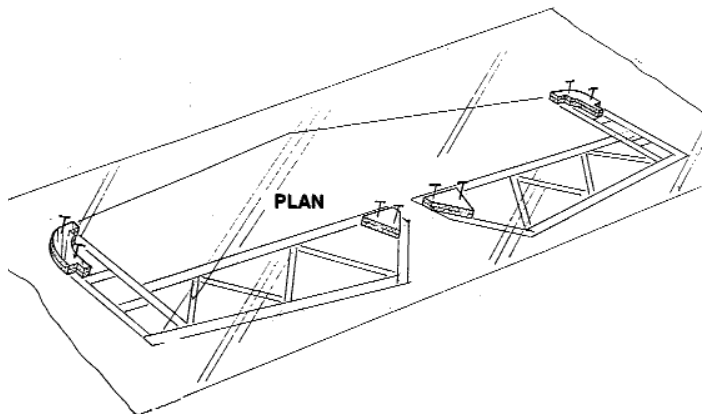

3.  Working over the plan, glue and pin the ELEVATOR AIR BALANCE L.E.s and the ELEVATOR HORN MOUNTS in place.

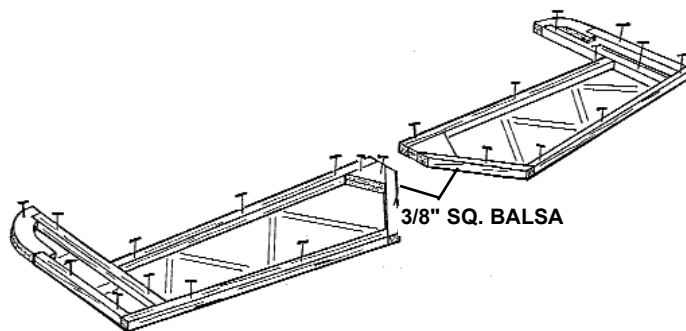

4.  Trim each PERIMETER STICK, as needed, and glue and pin in place over the plan.

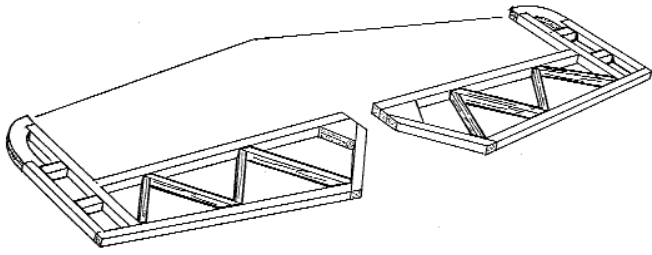

5.  Trim and glue the 3/16 x 3/8" TRUSS STICKS.

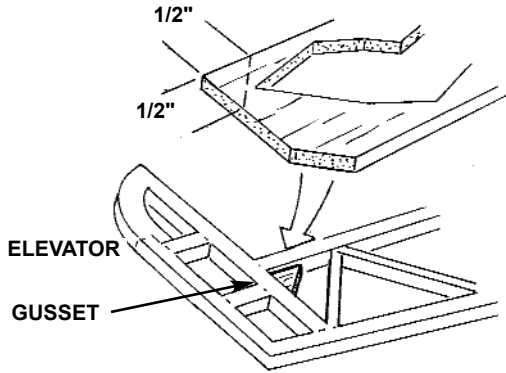

6.  From scrap 3/16" balsa, cut a piece 1/2"x 1/2" triangle to form a gusset.  
 Glue in place, as shown.

### VERTICAL FIN

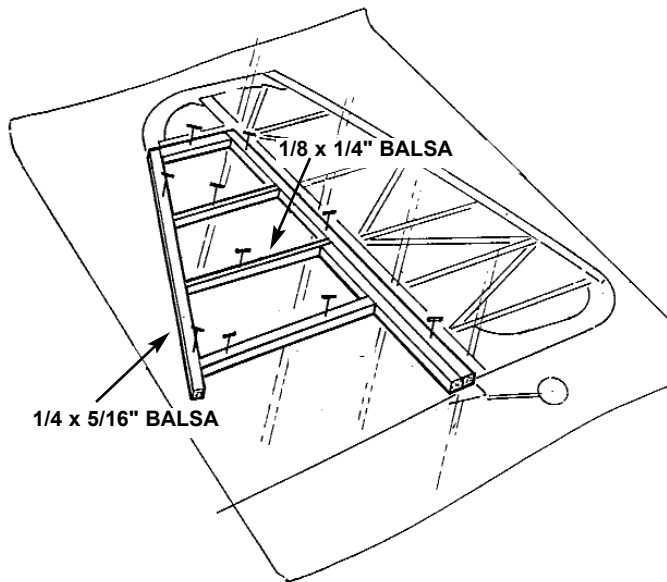

1.  After covering the fin portion of the FUSELAGE PLAN with waxed paper, begin trimming, gluing, and pinning the 1/4 x 5/16 balsa PERIMETER STICKS in place.  
 Next, trim and glue the 1/8 x 1/4 TRUSS STICK pieces in place.

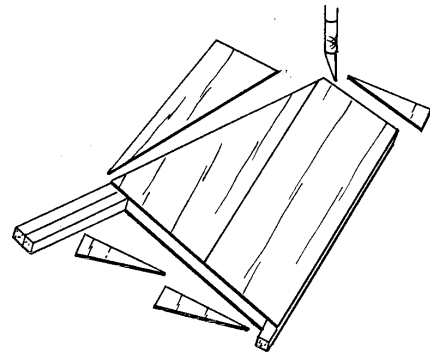
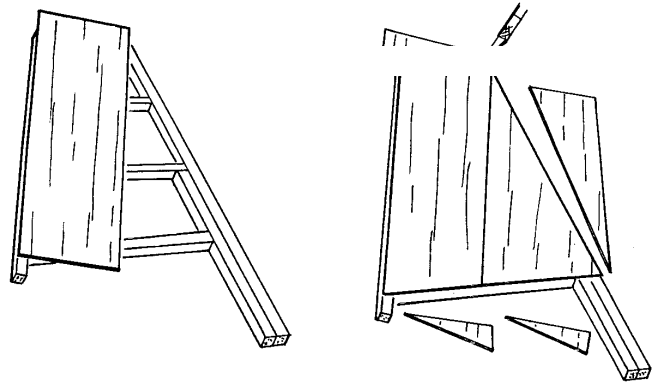

2.  Trim the SHEETING to fit the fin framework. When satisfied with the fit, glue in place.  
 Turn the fin over and sheet the other side of the fin structure.

**NOTE:** When covering the fin, **DO NOT** cover posts and bottom where the structure is to be glued to the fuse.

### RUDDER

RUDDER TOP

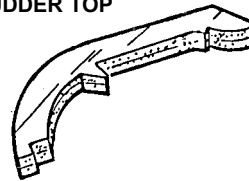

RUDDER BOTTOM

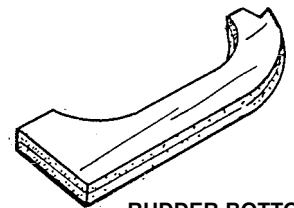

1.  Laminate the two RUDDER TOPS and RUDDER BOTTOMS.



## HINGING AND ROUNDING

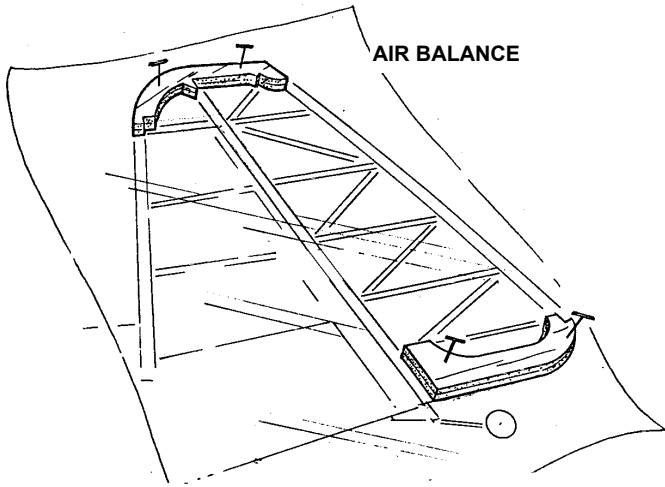

2.  Working over the rudder portion of the plan, place the laminated RUDDER TOP over the plan and trim, if needed. When satisfied with the fit pin in place.
  - Follow the same procedure for the laminated RUDDER BOTTOM.

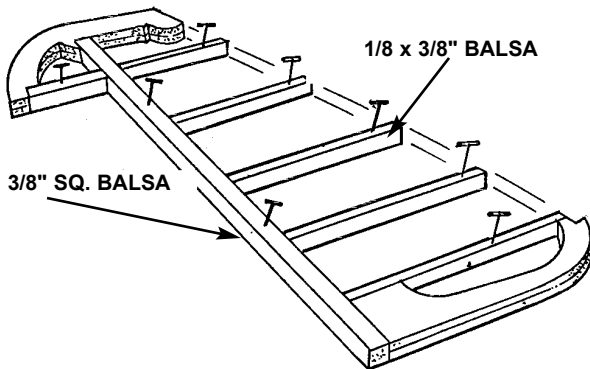

3.  Using 3/8" square balsa, glue the rudder L.E. to the rudder top.
4.  Use 1/8 x 3/8" balsa sticks, as shown, to form the trussing.

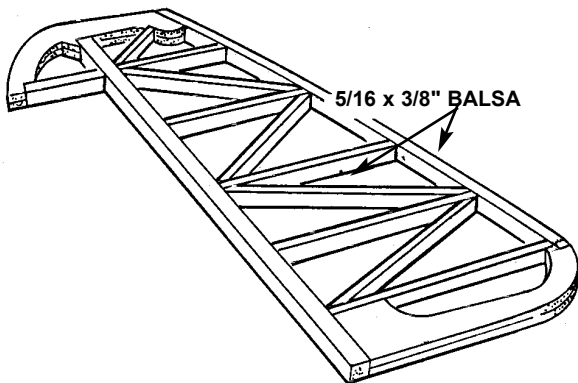

5.  Complete the trussing. Then use 5/16 x 3/8" balsa to form the rudder trailing edge.

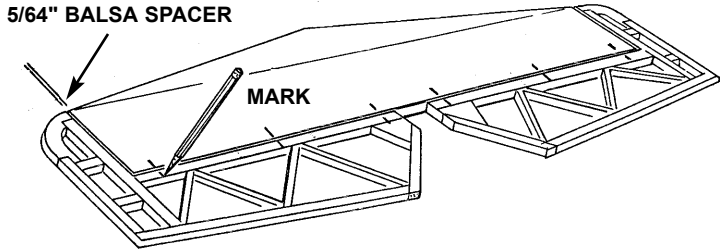

1.  Referring to the plans, mark the hinge locations onto the elevator.
2.  Fit the stab and the elevator together and, use balsa sheeting scrap to make a 5/64" spacer between the elevator air balance and the stab.
  - Then, transfer the hinge locations from the elevator to the stab.

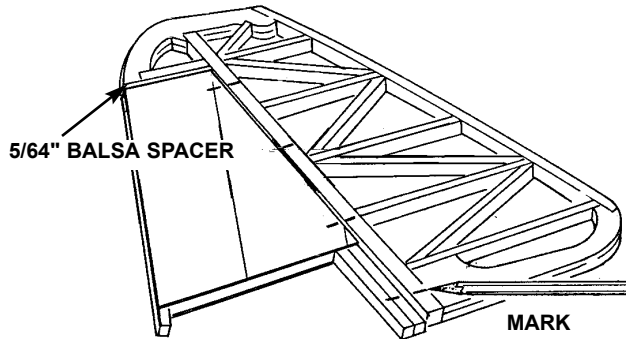

3.  Again referring to the plans, mark the hinge locations onto the rudder.
  - As in the previous step, make a 5/64" scrap balsa spacer between the fin and the rudder air balance.
  - Transfer the hinge locations from the rudder to the fin.

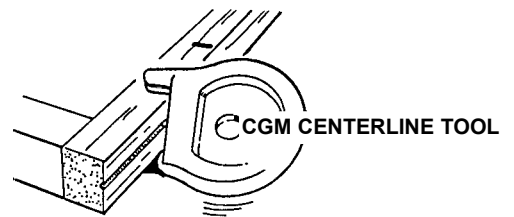

4.  Using the CGP CENTERLINE MARKER, scribe a centerline onto the elevator L.E.
  - Next, scribe a line onto the stab T.E.
  - Repeat this process with the rudder L.E. and the fin T.E.

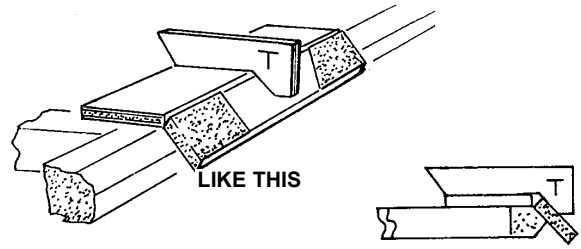

8.  Using the tool marked "T," bevel the rudder L.E. and the elevator L.E. to a point at the scribed centerline. Use a knife to bevel near the air balances, as the tool cannot get into the corner.
9.  Temporarily hinge the rudder/fin assembly and the elevator/stab assembly, in order to check the alignment and round the perimeter of the assemblies. You may wish to use masking tape to help hold the pieces together.

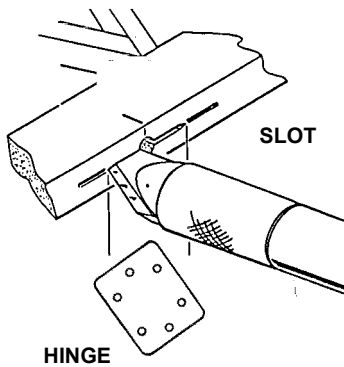

5.  Use a knife to make an slot on on the center-line for each hinge.
6.  Test fit each hinge, as you proceed.

**NOTE: DO NOT GLUE THE HINGES IN PLACE AT THIS TIME.**

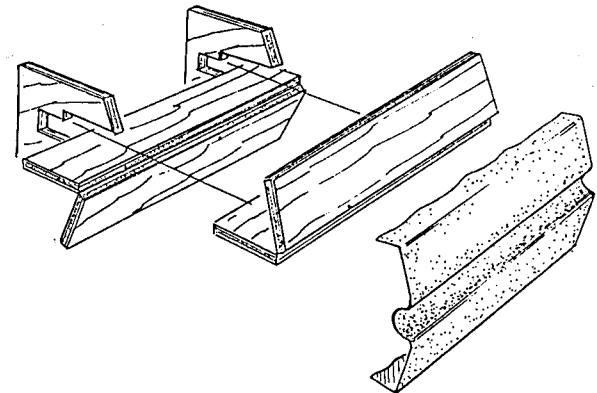

10.  Assemble the ROUNDING TOOL and insert, **but do not glue**, a piece of medium sandpaper

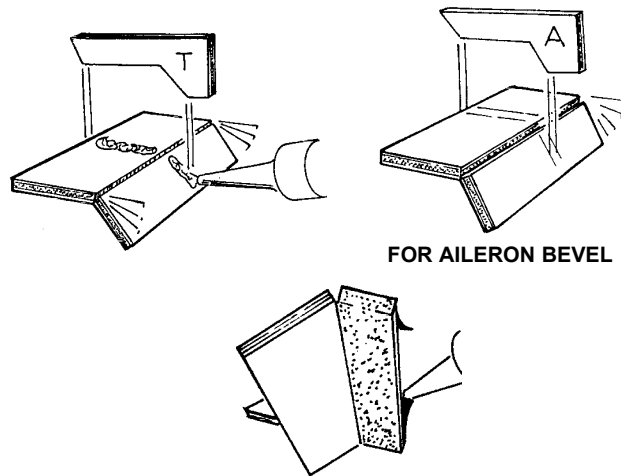

7.  From D/C sheet 6723, assemble the two BEVELING TOOLS.
  - Tack glue a piece of medium sandpaper onto each tool.

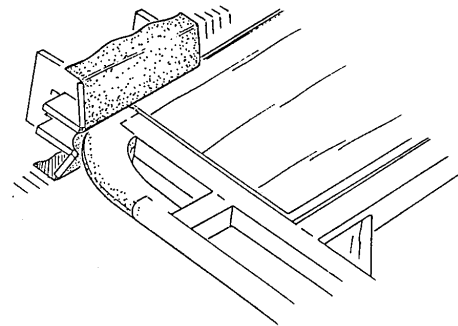

11.  Use the tool to round the perimeter of the fin/rudder assembly and the elevator/stab assembly.
  - When satisfied with the shape, change the sandpaper to fine grit and repeat Step 10 to smooth the rough surface.
12.  Finish sand the entire surface of both assemblies, using a sanding block with fine grit sandpaper. Then separate the fudder from the fin and the stab from the elevator.

**THIS COMPLETES THE TAIL OF THE AIRCRAFT. SET THE PARTS ASIDE UNTIL LATER.**

# WING CONSTRUCTION

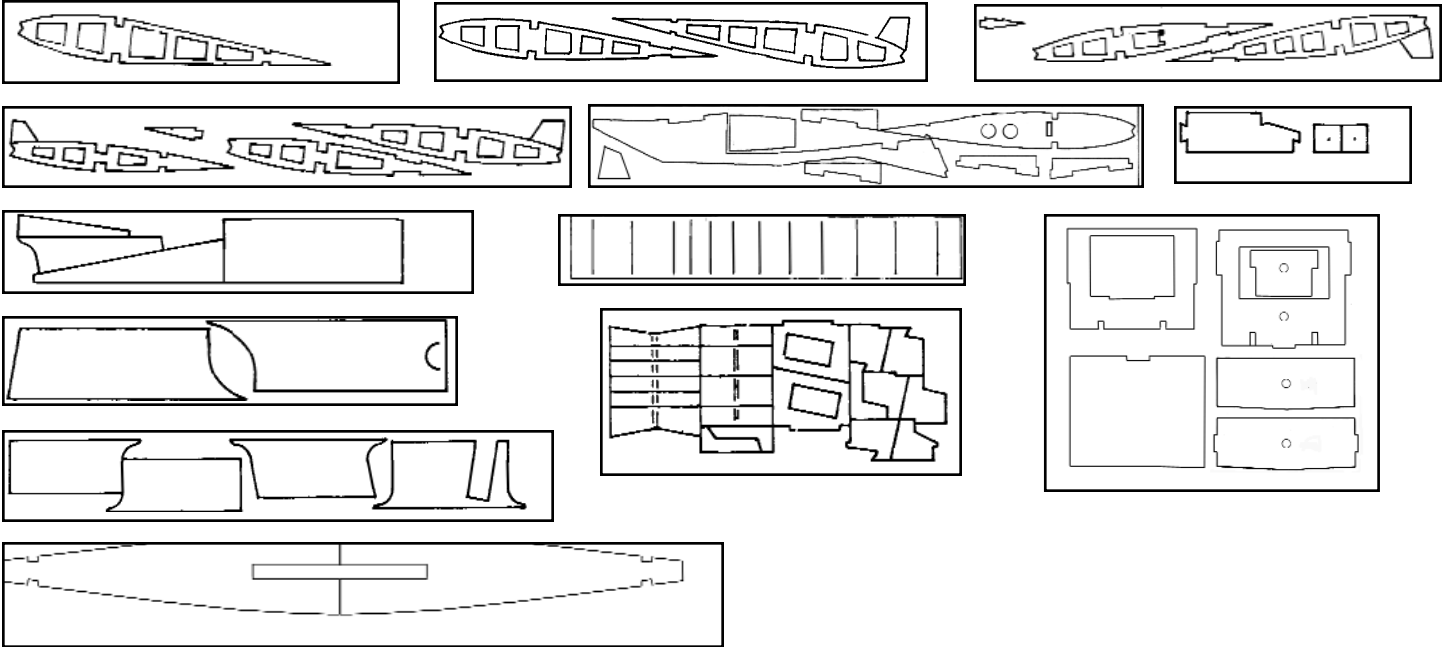

1.  Gather the parts needed to construct the wing:

- (2) D/C SHT. 6725 5/64" BALSAL PT. # 3656  
CONTAINS WING RIB #3
- (2) D/C SHT. 6714 5/64" BALSAL PT. #3688  
CONTAINS WING RIB #4 & #5
- (2) D/C SHT. 6715 5/64" BALSAL PT. #3689  
CONTAINS: WING RIB #6 & 7,  
AND AILERON RIB
- (2) D/C SHT. 6716 5/64" BALSAL PT. #3690  
CONTAINS: WING RIB #8, #9,  
#10, AND AILERON RIB
- (1) L/C SHT. 6732 PLY PT. #3652  
CONTAINS: WING JOINER FRONT  
WING JOINER REAR,  
WING DOWEL SCAB PLATE
- (1) L/C SHT. 6730 BALSAL PT. #3654  
WING CENTER RIB
- (2) L/C SHT. 6731 PLY PT. #3653  
CONTAINS: RIB #2, RIB #2 TAB,  
WING CENTER DOUBLER
- (1) D/C SHT. 6726 PLY PT. #3658  
CONTAINS :  
(1) RIB SPACING GAUGE  
(2) WING BOLT PADS
- (2) D.C SHT. 6718 BALSAL PT. #3692  
CONTAINS:(8)SHEAR WEB
- (4) D/C SHT. 6719 5/64" BALSAL PT. #3693  
CONTAINS:  
(2) WING TIP SHEETING  
(1) AILERON SERVO COVER SHEETING  
(4) WING CENTER SHEETING
- (4) D/C SHT. 6720 5/64" BALSAL PT. #3694  
CONTAINS:

- (2) WING CENTER SHEETING
- (2) D/C SHT. 6722 5/64" BALSAL PT. #3695  
CONTAINS:  
(2) WING TIP SHEETING  
(2) AILERON SERVO COVER SHEETING
- (1) D/C SHT. 6723 PLY PT. #3697  
CONTAINS:  
(2) AILERON SERVO MOUNT  
(8) DIHEDRAL FIXTURES
- (5) MAIN SPARS PT. #3700  
(3/8 x 3/8 x 35-1/8" BASS)
- (8) AFT SPARS PT. #3701  
(1/8 x 1/4 x 35-3/4" BALSAL
- (4) HINGE STICK PT. #3702  
(1/4 x 1 x 25-1/2" BALSAL
- (2) WING TIP BLOCK PT. #3703  
(1-1/4 SQ x 10" BALSAL
- (1) T.E. BACK-UP PT. #3704  
(1-3/4 TAPERED x 7" BALSAL
- (2) SHAPED L.E. PT. #3705
- (12) WING SHEETING PT. #3706
- (4) CAPSTRIPS PT. #3707  
(5/64 X 1/4 X 22" BALSAL
- (1) LANDING GEAR PLATE PT. #3708  
(1/4 x 2-1/4 x 6-1/4" PLY)
- (1) NYLON TAPE PT. #3709
- (4) #6-32 x 1" SOCKET HD. SCREW PT. #1023
- (4) #6 WASHER PT. #1140
- (10) LARGE FLEX-POINT HINGE PT. #1449
- (1) WING DOWEL PT. #1750  
(5/16 x 4-1/2" ASH)
- (1) BEVEL TOOL "A" PREVIOUSLY CON-  
STRUCTED.

## WING

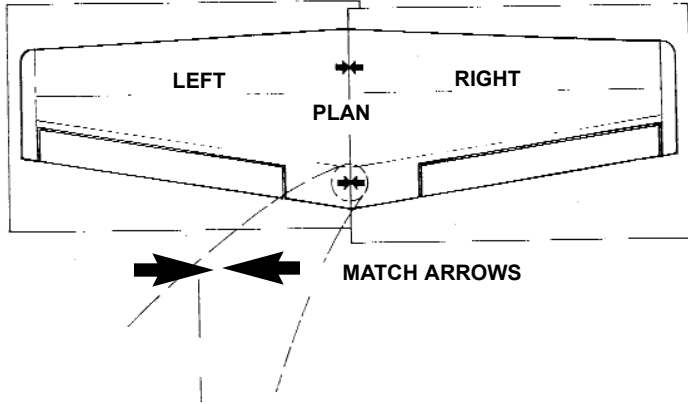

2.  Cut the plan along the dotted line.
- Position the left wing plan over the right wing plan, aligning the arrows and main spar lines, as shown.
- Pin or tape the plan to the building board and place a sheet of waxed paper over the entire wing plan.

**START THE WING CONSTRUCTION BY FIRST BUILDING THE RIGHT WING HALF.**

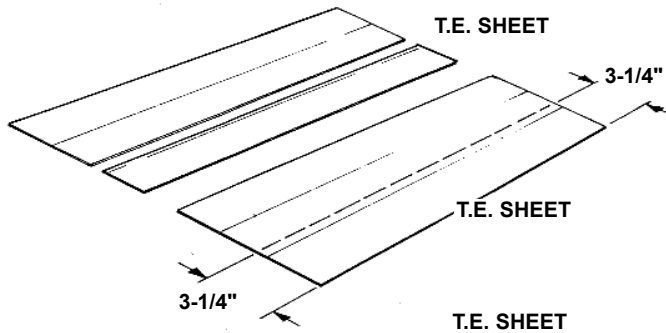

3.  Edge-glue two assemblies of three 5/64 x 3 x 36" balsa.
- Measure 3-1/4" from each end of both assemblies and cut, as shown, to make T.E. SHEETS.

NOTE: The remainder of the sheeting will be used later for the leading edge.

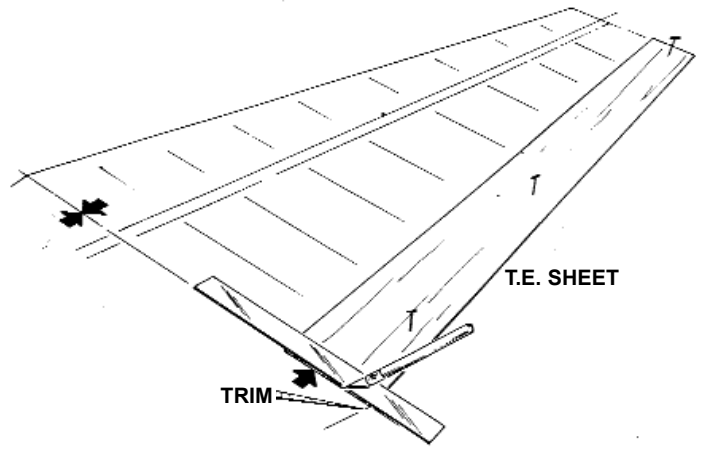

4.  Pin a T.E. sheet over the plan.
- Align a straight-edge with the wing centerline and trim the sheet even with the centerline.

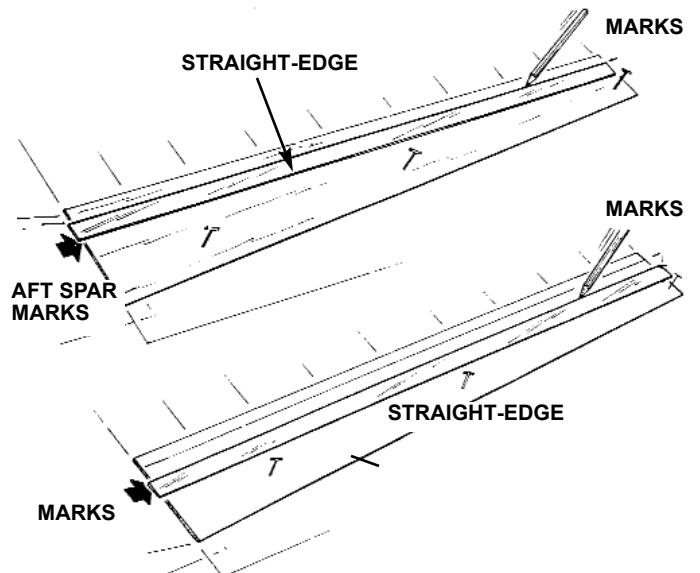

5.  Align a straight-edge with the aft spar marks on the plan and draw lines on the sheeting to locate the spars.

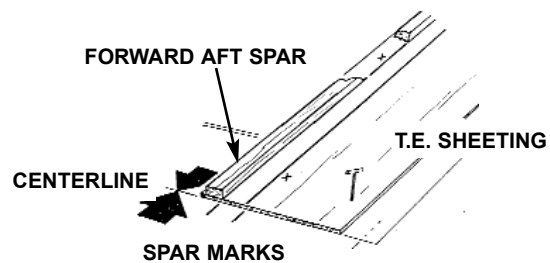

6.  Position the 1/8 x 1/4 x 36" FORWARD AFT SPAR on the T.E. sheet, in front of the front line.

NOTE: Make sure the spar end is flush with the centerline edge of the T.E. sheet.

- Glue the spar in place.

**TAPE BOTH SIDES**

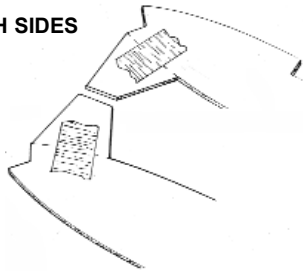

7. □ Tape both sides of the tab break-off line on all of the tabbed ribs.

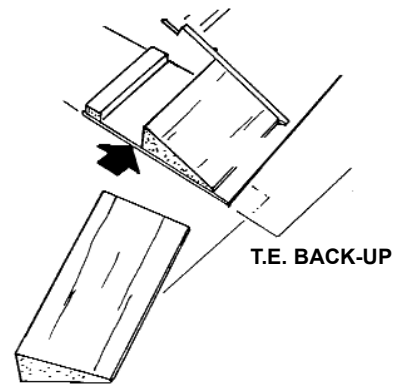

- Cut off the back-up flush with the wing centerline.

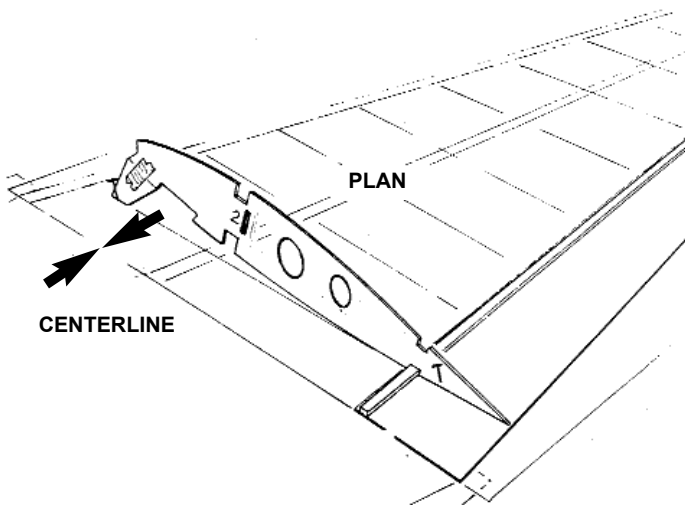

9. □ Locate Rib #2 over the plan and glue it to the T.E. sheet.

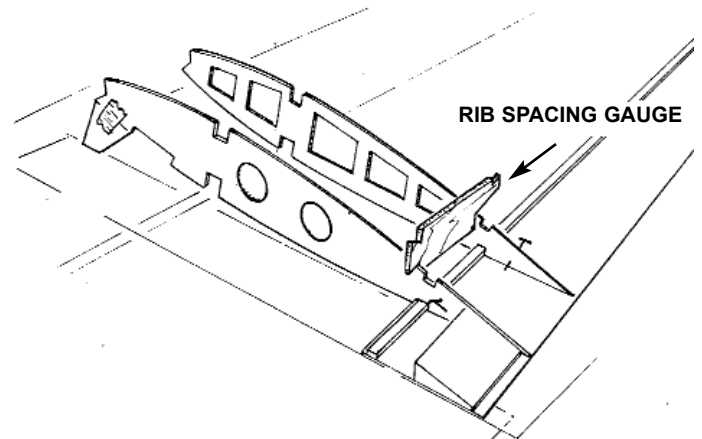

11. □ Use the Plan to locate the distance between Rib #3 and Rib #2.

**NOTE:** Because the plan paper can stretch somewhat, due to variations in humidity, the plan is not always an accurate representation of the desired results. Therefore, to guarantee the ribs are spaced correctly, a rib spacing gauge is provided. Use this gauge to measure the distance from the previously installed rib to the next, making sure that all ribs are parallel.

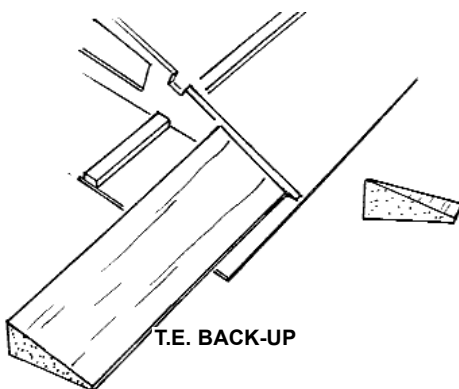

10. □ Angle-cut the T.E. BACK-UP to fit tight against Rib 2.

- With the back-up flush with the top of the rib, glue the back-up to the trailing edge sheet.

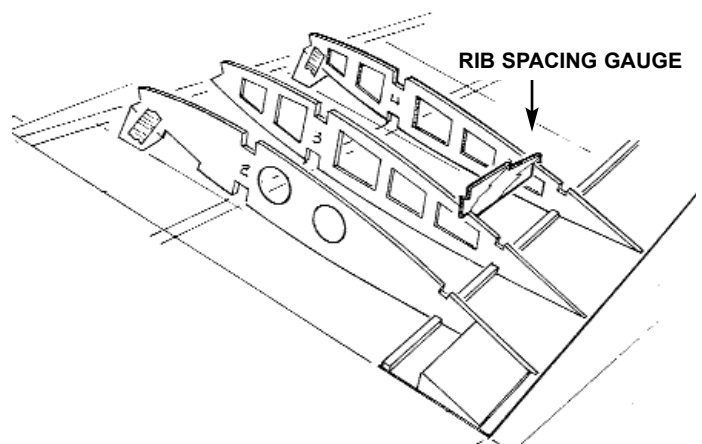

12. □ Use the long side of the rib spacing gauge to position Rib #4 from Rib #3.

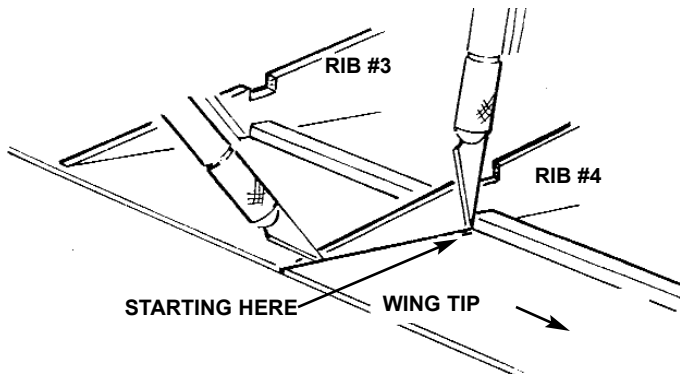

13. □ Using the wing-tip side of Rib #4 as a guide, cut through the trailing edge sheeting.

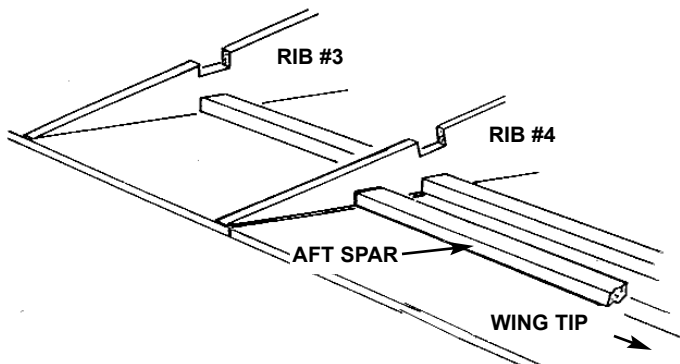

14. □ Cut a 1/8 x 1/4" balsa aft spar to a 10-3/4" length and butt one end against Rib #4.  
 □ Glue to the T.E. sheeting along the edge of the rear line, as shown.

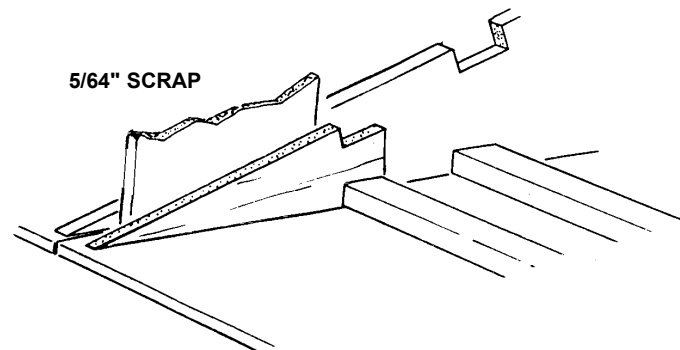

15. □ Using 5/64" scrap balsa as a spacer, glue an AILERON RIB to the aft spar and the T.E. sheeting.

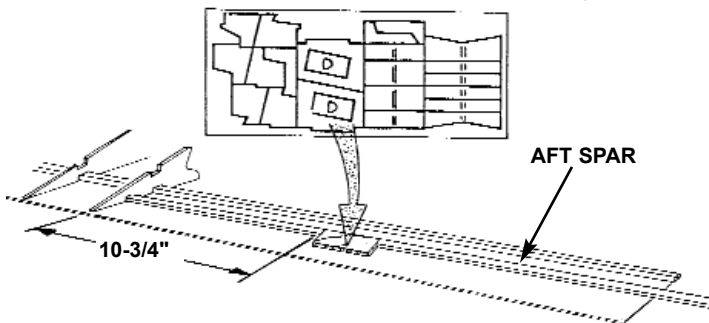

16. □ From D/C sheet 6723, take an AILERON HORN BACK-UP, marked "D" and glue it to the T.E. sheeting, in line with the aft spar.

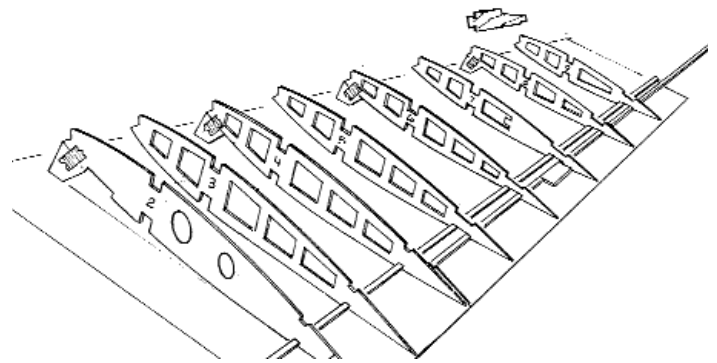

17. □ Using the long side of the rib spacing gauge, locate ribs #5 through #9, gluing each of them to the T.E. sheet.

**NOTE:** Make sure that the ribs are parallel to the ribs on the plan, before gluing.

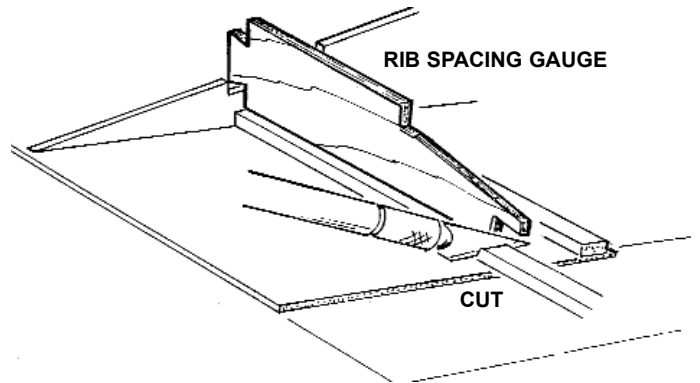

18. □ With the long side of the rib gauge, locate the cut-off mark on the back of the aft spar, and cut.

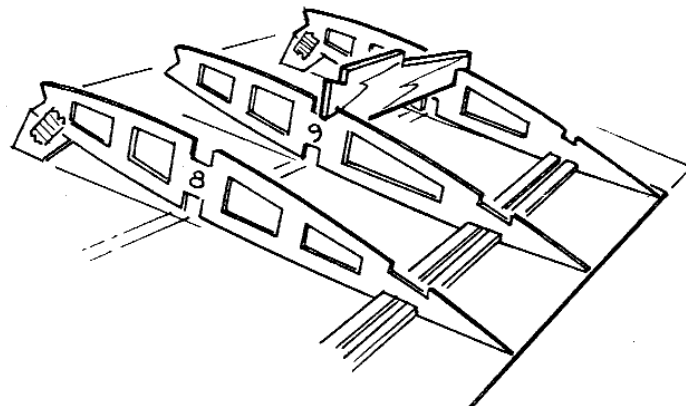

- Install Rib #10.

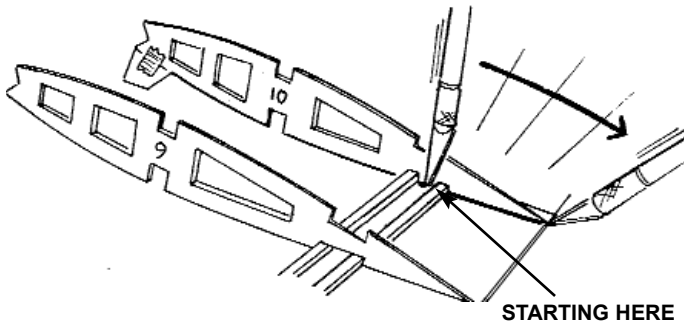

19. □ Using Rib #10 as a guide, cut through the T.E. sheeting along the wing center side of the rib.

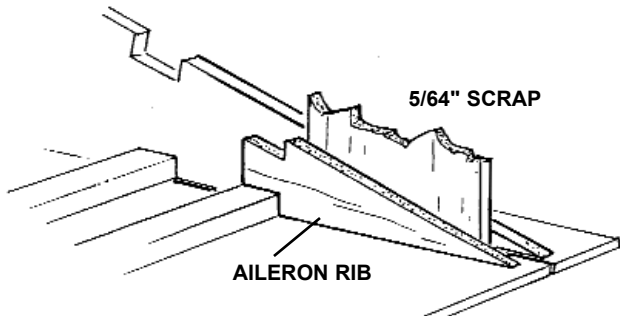

- Again using the 5/64" scrap spacer, locate and glue the aileron rib to the trailing edge sheeting.

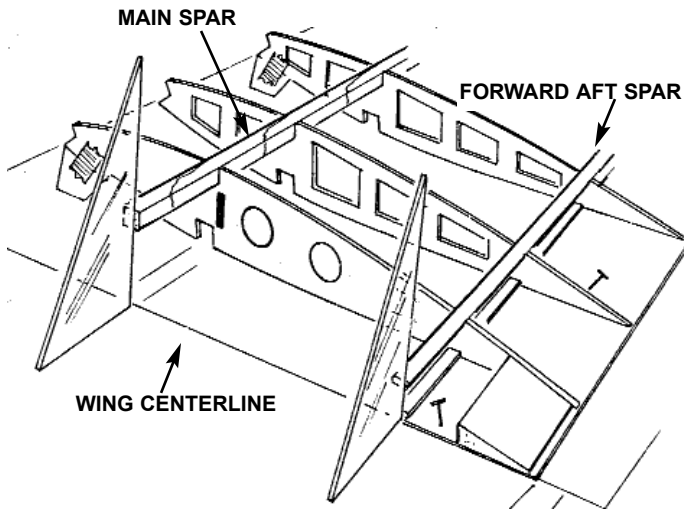

20. □ With the end flush with the centerline of the wing, insert the TOP MAIN SPAR into the rib notches and glue at each rib.  
 □ Again with the spar flush with the centerline, insert the FORWARD AFT SPAR and glue in place.

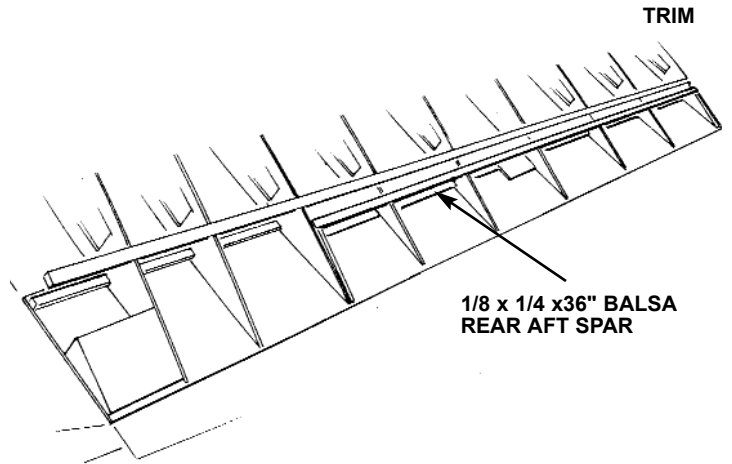

21. □ Trim the rear aft spar to fit and glue to the ribs.

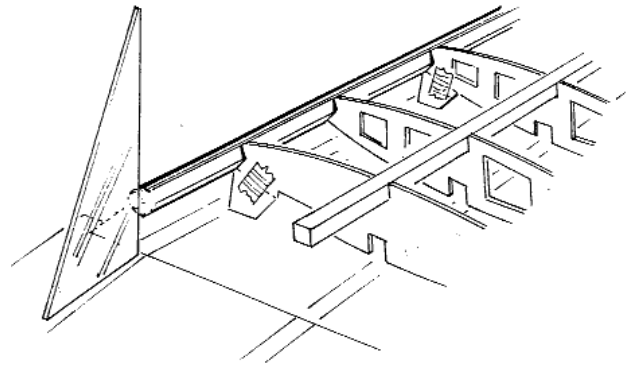

22. □ Position the SHAPED LEADING EDGE on the wing centerline and then glue the L.E. to each rib.

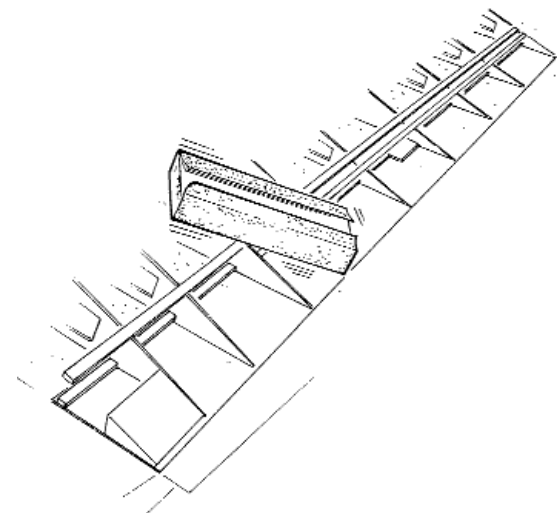

23. □ Using **fine grit** sandpaper, flat sand the tops of the ribs flush with the aft spars.

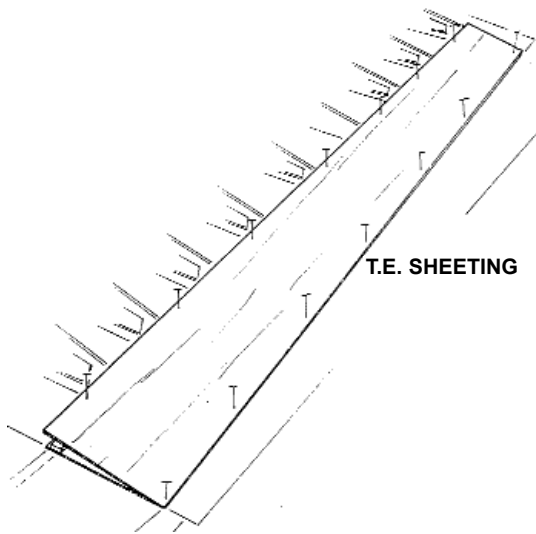

24.  Glue the top T.E. SHEETING to the spars, ribs, and the bottom T.E. sheet.

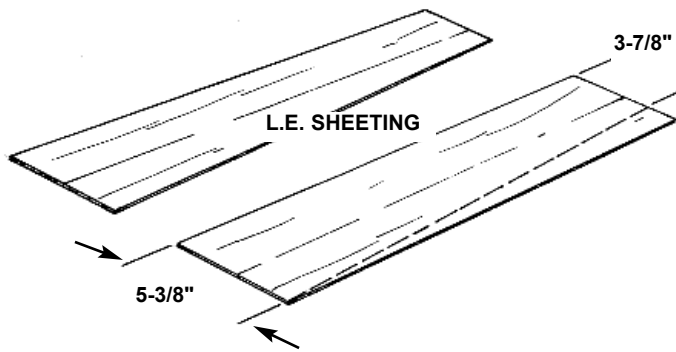

25.  From the remainder of the edge-glued sheeting used for the T.E., measure a width of 5-3/8" from one end and 3-7/8" at the other end.
- With a straight-edge, draw a line from one mark to the other. Then cut the sheeting along the line, creating two tapered pieces.

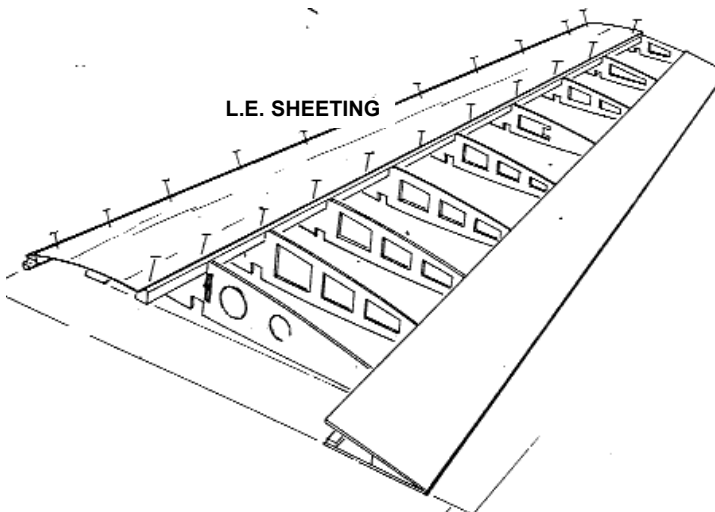

26.  Glue and pin the L.E. sheet to the shoulder on the leading edge, the rib camber, and the spar.

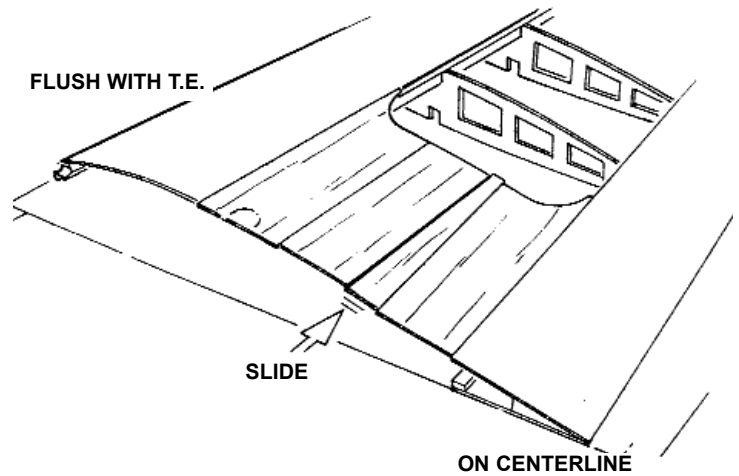

27.  Making sure the servo wire knock-out hole is on the piece closest to the L.E., glue the three large pieces of CENTER SHEETING to the ribs, the L.E. and the T.E..
- Pre-fit a wedge-shaped piece of sheeting to fill the center area.
- When satisfied with the fit, apply glue and slide the piece into place, as shown.

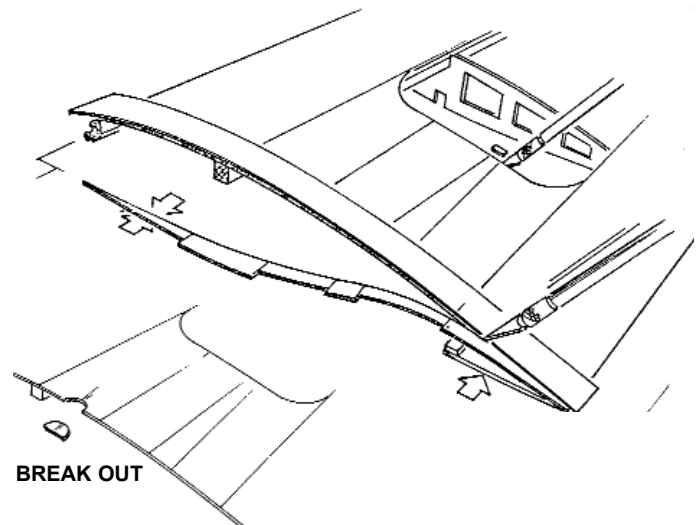

28.  Use a flexible straight-edge to trim the sheeting flush with the wing centerline.
- Punch out the knock-out hole in the sheeting to provide access for the servo wire.



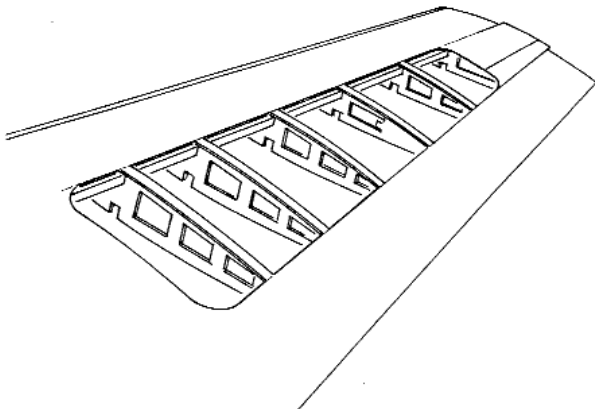

29. □ Trim and then glue the WING TIP SHEETING and the 5/64" balsa capstrips in place.

THIS COMPLETES THE RIGHT WING HALF. SET IT ASIDE AND PLACE **THE LEFT WING HALF OF THE PLAN** IN THE CENTER OF THE BUILDING BOARD. Begin building the left wing at Step 3.

**DO NOT BUILD THE SECOND WING PANEL OVER THE SAME PORTION OF THE PLAN!**

WHEN THE SECOND WING PANEL IS COMPLETE, REMOVE IT FROM THE BOARD AND CONTINUE TO THE NEXT STEP.

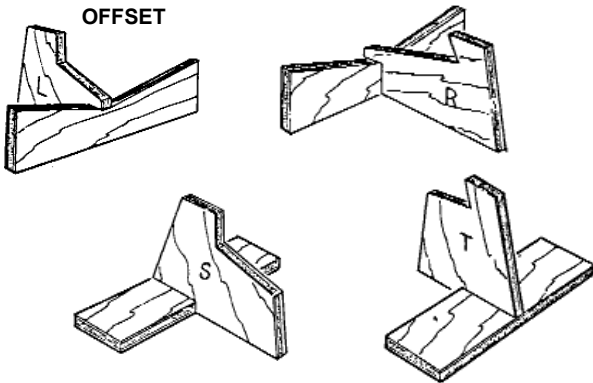

30. □ Assemble the DIHEDRAL FIXTURES, as shown. Note that one is offset. This fixture will not be needed in construction of this second edition Sukhoi.

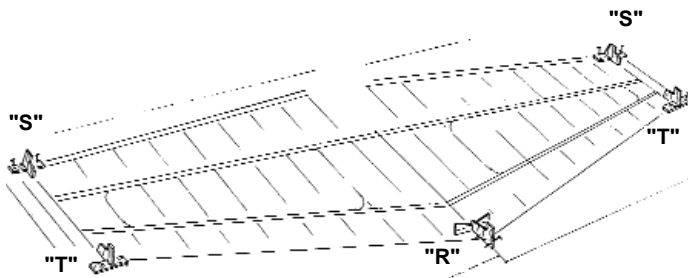

31. □ Working over the full waxed-paper-covered wing plan, pin or glue the fixtures in place, as shown above.

WING IS BOTTOM-SIDE UP

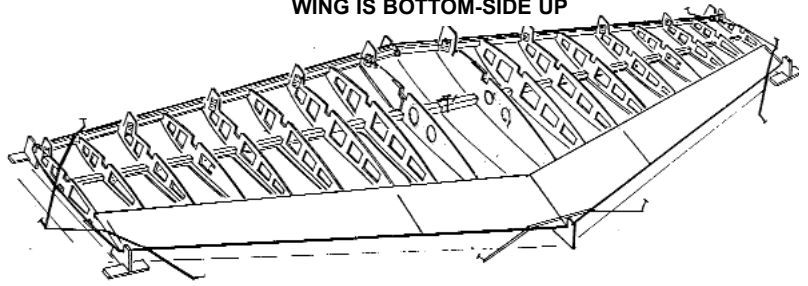

32. □ Place the wing panels onto the fixtures with the bottom (open framework) facing up.  
 □ Check the centerline fit and, if necessary, sand to improve fit.  
 □ When satisfied with the fit, you may wish to anchor in place with pins and rubber bands, as shown.

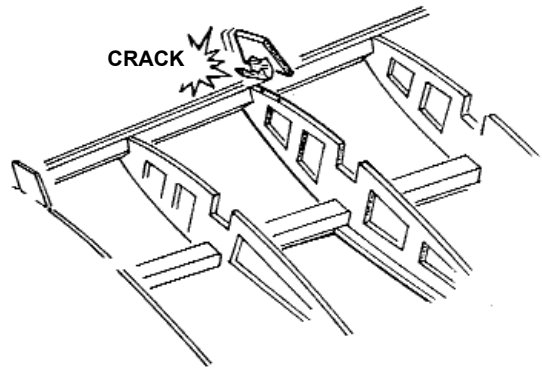

33. □ Carefully remove the reinforcing tape and crack off all of the wing support tabs.

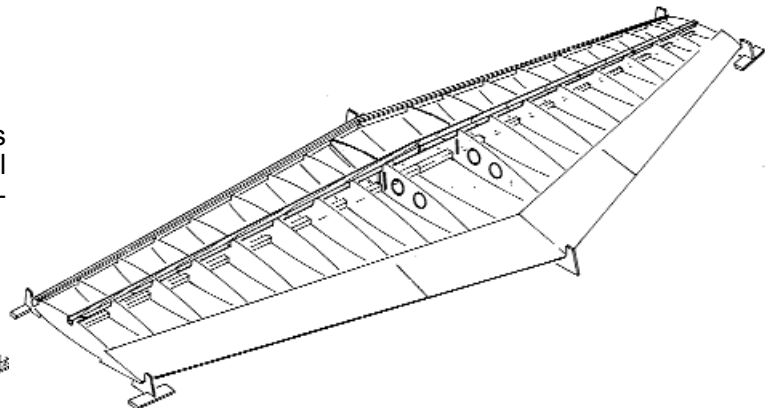

34. □ Test fit and then glue the MAIN SPARS to each wing rib.

**FRONT WING JOINER**

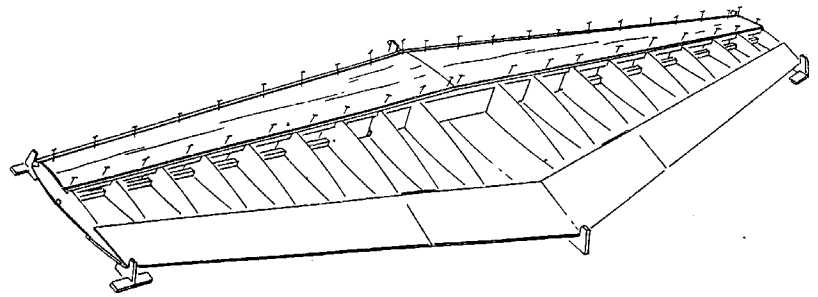
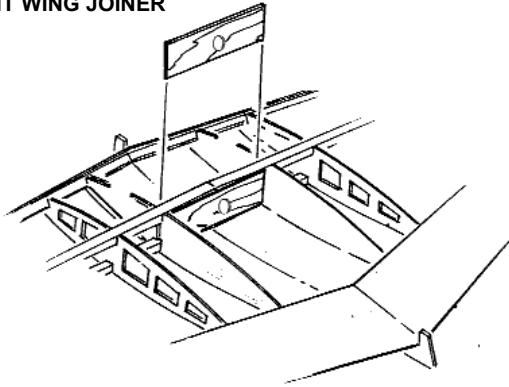

- 35.  Test fit the front and rear WING JOINERS between the two #2 ribs, as shown. Note the rear joiner tabs which fit into the rib slots.
  - Sand any parts, as necessary, to improve the fit of the two wing halves.
- 36.  When satisfied with the fit, apply JET Epoxy 20 along the centerline of both wing panels and spars and glue them together.
  - Epoxy the wing joiners securely in place.
  - After making sure all elements are correctly aligned, allow epoxy to thoroughly cure before proceeding. You may wish to use clamps to hold the assembly tightly together.

- 38.  Test fit the L.E. sheeting. When satisfied with the fit, apply glue to the top of the L.E., the front rib tops, and the top of the main spar.
  - Install the sheeting and pin in place, as shown. Allow to dry thoroughly.

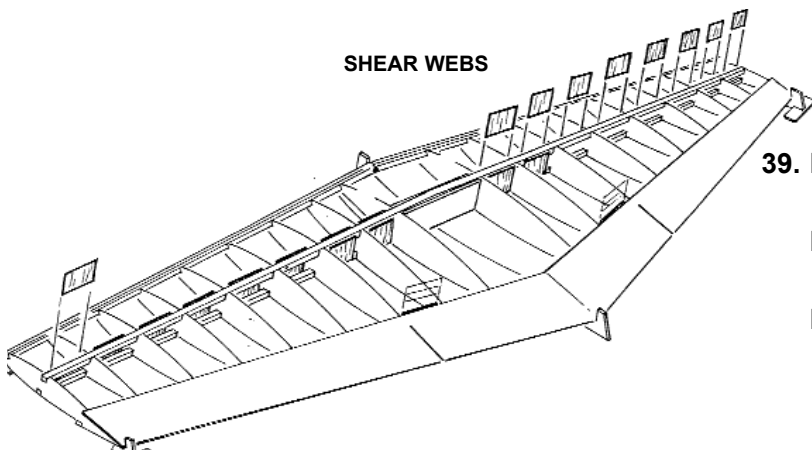
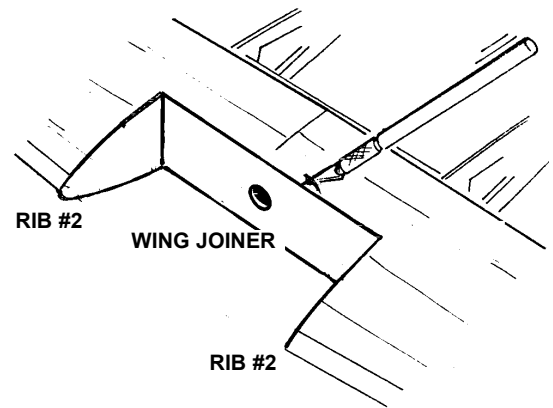

- 39.  When dry, determine the two Rib #2 locations and make a mark on the leading edge.
  - Make a second mark at the location of the wing joiner/spar assembly.
  - Referring to the above diagram, and **taking care not to cut into the ribs or the wing joiner**, use a razor saw and/or a hobby knife to cut the L.E. and the L.E. sheeting back to the wing joiner/spar assembly between the two #2 Ribs.

37.  Beginning at the wing tips, use Super Jet to glue the corresponding SHEAR WEBS to the **front side** of the top and bottom main spars in each rib bay.

**NOTE: The web that goes between Rib #2 and Rib #3 must be trimmed to fit.**

- Center the Rib #2/3 web between the two ribs and glue in place.

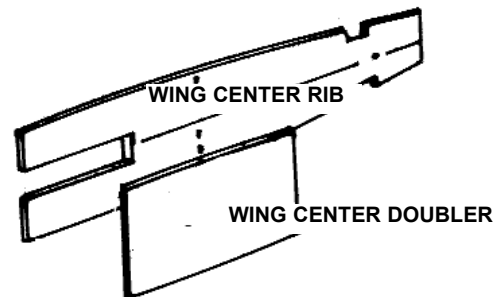

- 40.  Take one of the WING CENTER RIBS and laminate a WING CENTER DOUBLER to the outboard side.

- Take the second center rib and repeat the above lamination, taking care to make a **right center rib** and a **left center rib**.

41.  Laminate the two center ribs together, creating a single four-ply center rib with the doublers facing the wing tips.

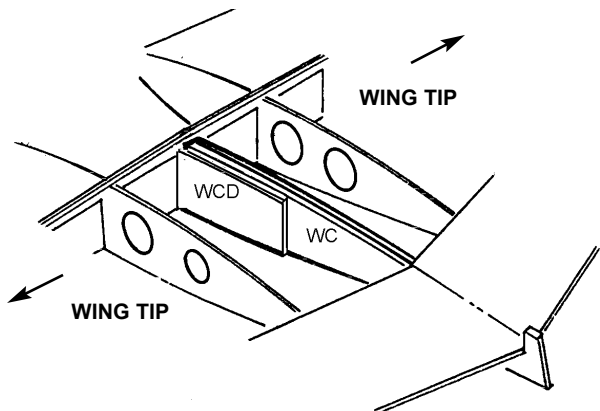

42.  Insert the center rib assembly, as shown, and then test fit the dowel, making sure it slides through the hole in the wing joiner and into the center of the rib assembly.

- When satisfied with the fit, glue the rib assembly and then the dowel in place.

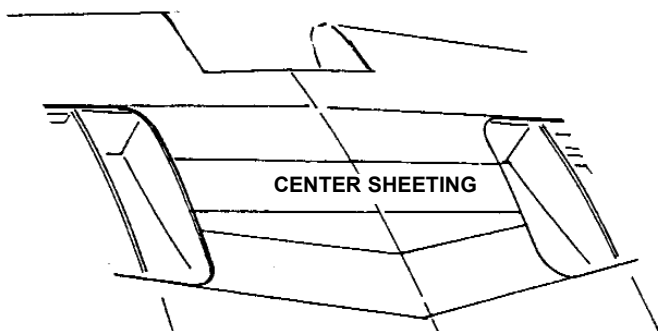

43.  Test fit and then install the CENTER SECTION SHEETING.

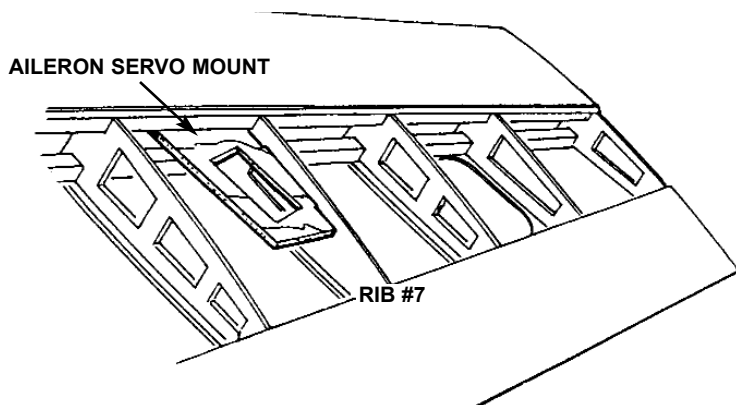

44.  Glue the AILERON SERVO MOUNT into the upper slot of Rib #7 and onto the top of the spar.
- Repeat for the other wing panel.

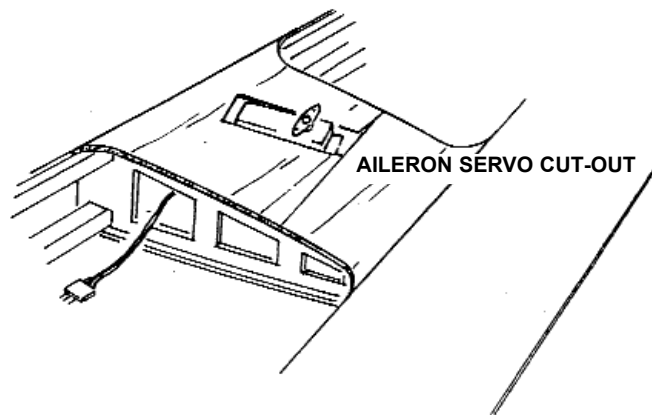

45.  Temporarily mount the servo, and mark the AILERON SERVO COVER SHEETING accordingly.

- Make a cut-out for the servo.

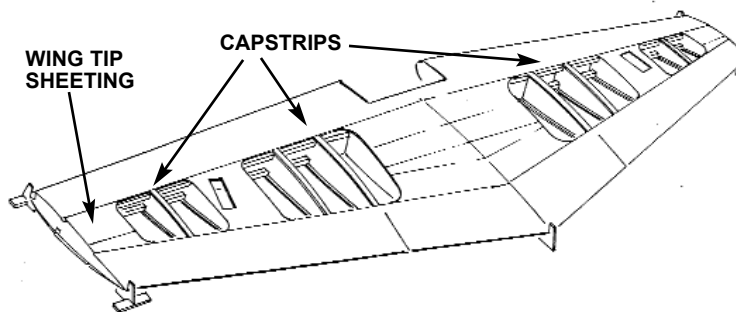

46.  Install the capstrips and the wing tip sheeting.

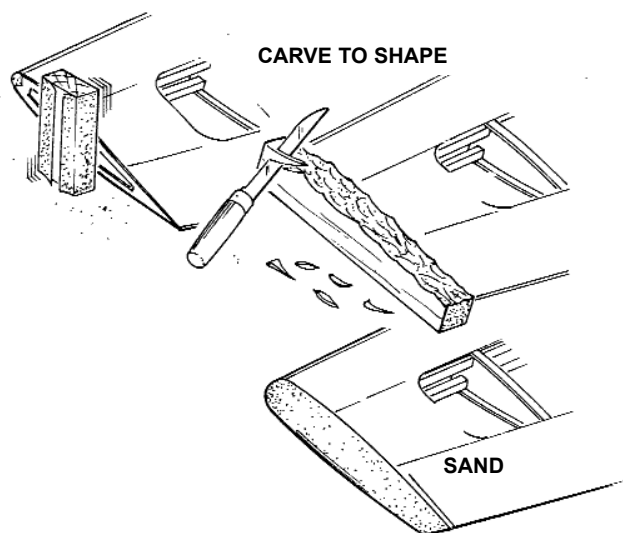

47.  Remove the wing from the fixtures and flat sand the end ribs, as shown.

48.  Cut the 1-1/4" square WING TIP BLOCK in two equal pieces and glue each piece to the end ribs.

- Rough carve the tips to the shape of the rib.

- Using first **medium grit**, and then **fine**, sandpaper, sand the both wing tips to a rounded and tapered final shape.
49. □ Finish sand the entire wing surface, top and bottom.

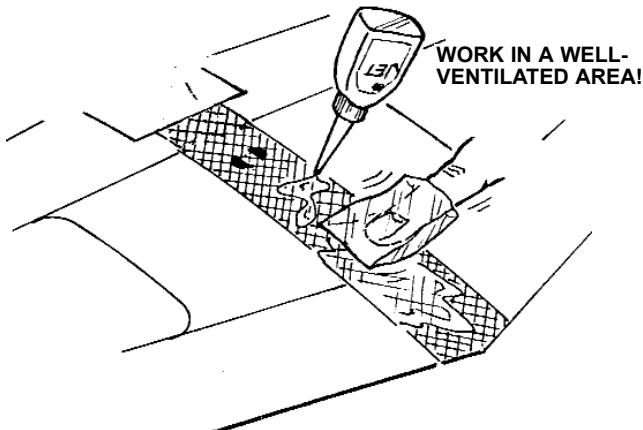

50. □ **WORKING IN A WELL-VENTILATED AREA and with plastic wrap or a plastic bag covering your finger**, completely wrap the center joint of the wing (top and bottom) with 2-1/2 " nylon tape, smoothing a liberal amount of glue into the fabric, as you go.

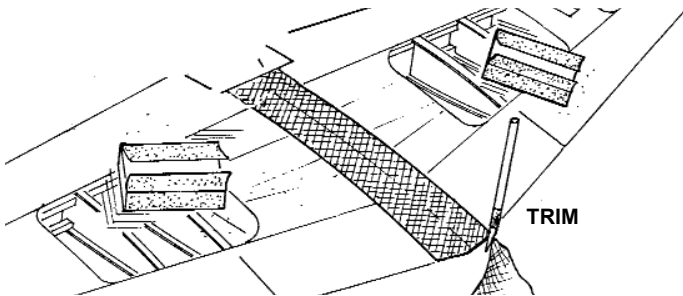

- Cut a hole for the dowel and, when the wing is fully wrapped, trim off any excess tape.

## AILERON

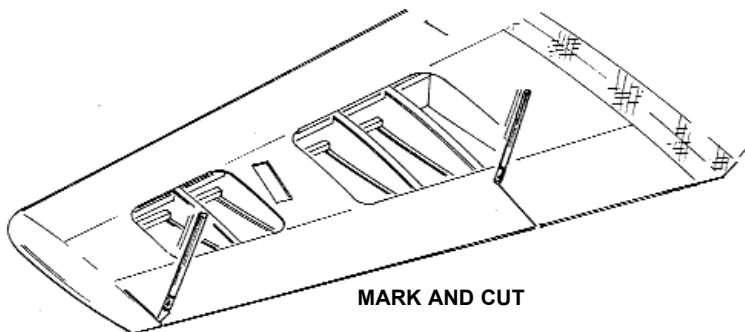

1. □ Referring to the plan, determine the aileron cut lines and transfer onto the bottom sheeting of the wing trailing edge.
- Then, carefully cut through the sheeting, as shown.

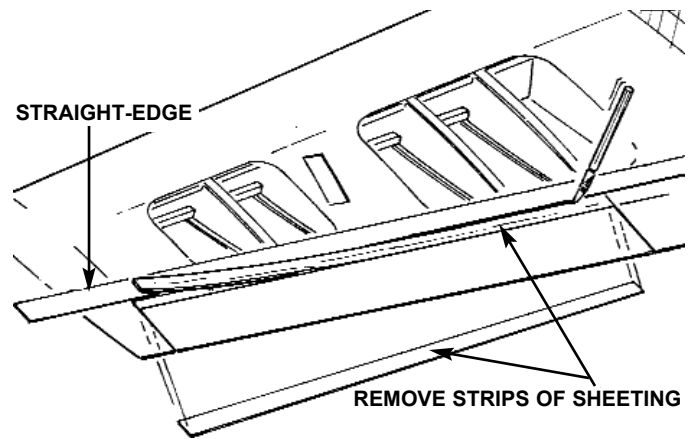

2. □ Using a straight-edge, remove a strip of sheeting between the two aft spars, as shown.

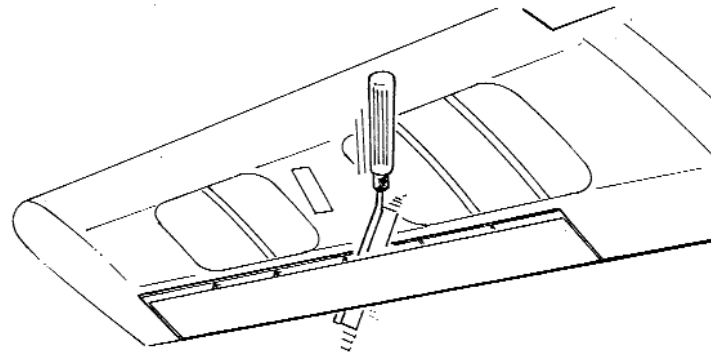

3. □ Using a razor saw, cut through the ribs and the T.E., between the two aft spars, to separate the ailerons from the wing.

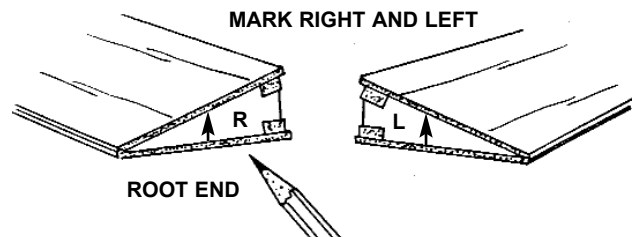

- Mark "top right" and "top left" on the root end of each aileron, so that you will know which piece fits into the left wing half and right right wing half.

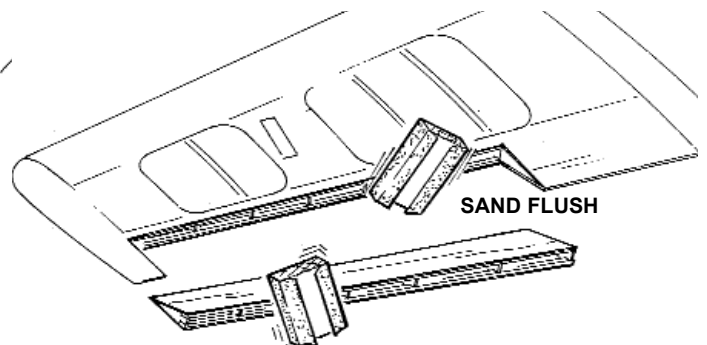

4. □ Trim the sheeting back flush with the aft spars on both the aileron and the wing.
- Flat sand along the entire length of the spar.

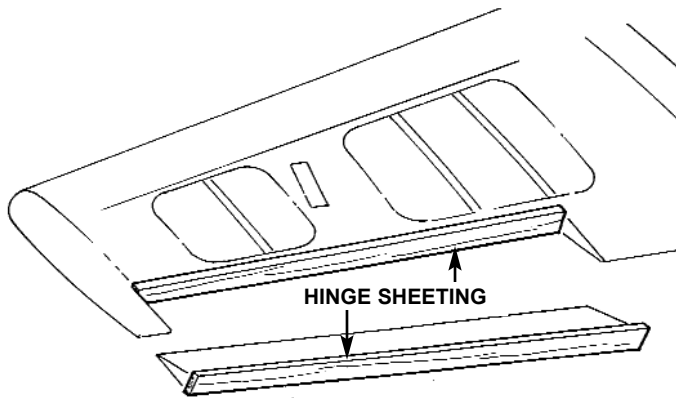

5.  Trim to fit and then glue a 1/4" balsa HINGE SHEETING onto both the ailerons and the wing.

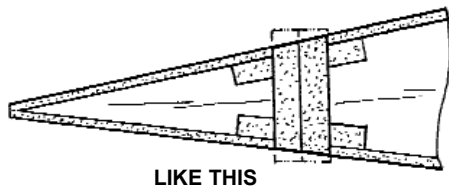

- Sand flush to the wing and to the aileron airfoil profile.
6.  Using the CGP centerline marker, scribe a centerline onto both the aileron and the wing.
- Transfer the hinge locations from the plan onto the wing and the aileron.

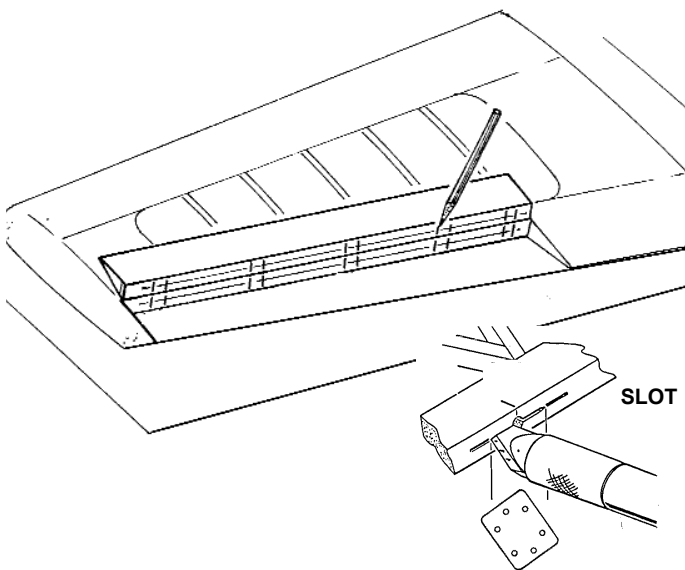

7.  Following the same procedure used when constructing the control surfaces on the tail. Slot each of the hinge locations.

**AILERON BEVEL GAUGE**

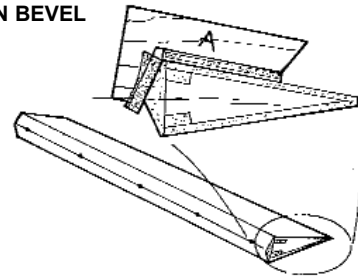

8.  Using the previously constructed Bevel Tool "A", bevel both sides of the ailerons.
- Test fit the ailerons to the wing, but do not permanently install until after they have been covered.

**NOTE: MAKE SURE YOU CAN IDENTIFY THE LEFT AND THE RIGHT AILERON. YOU WILL NEED TO SCREW THE CONTROL HORN INTO THE PLY BACKUP LOCATED INSIDE.**

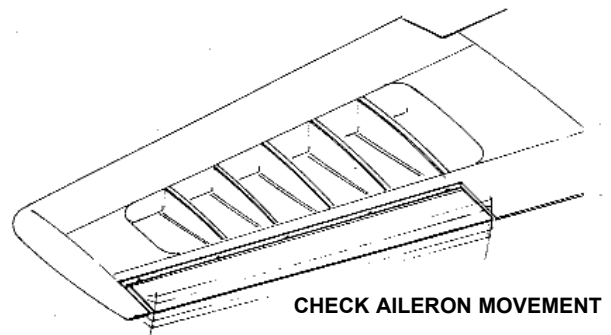

9.  Carefully check the wing for any nicks and deep scratches and fill with CGP Model Mate™. Finish sand any areas that will detract from the appearance of your model after it is covered.

**THIS COMPLETES CONSTRUCTION OF THE WING. SET IT ASIDE UNTIL IT IS NEEDED.**

# FUSELAGE CONSTRUCTION

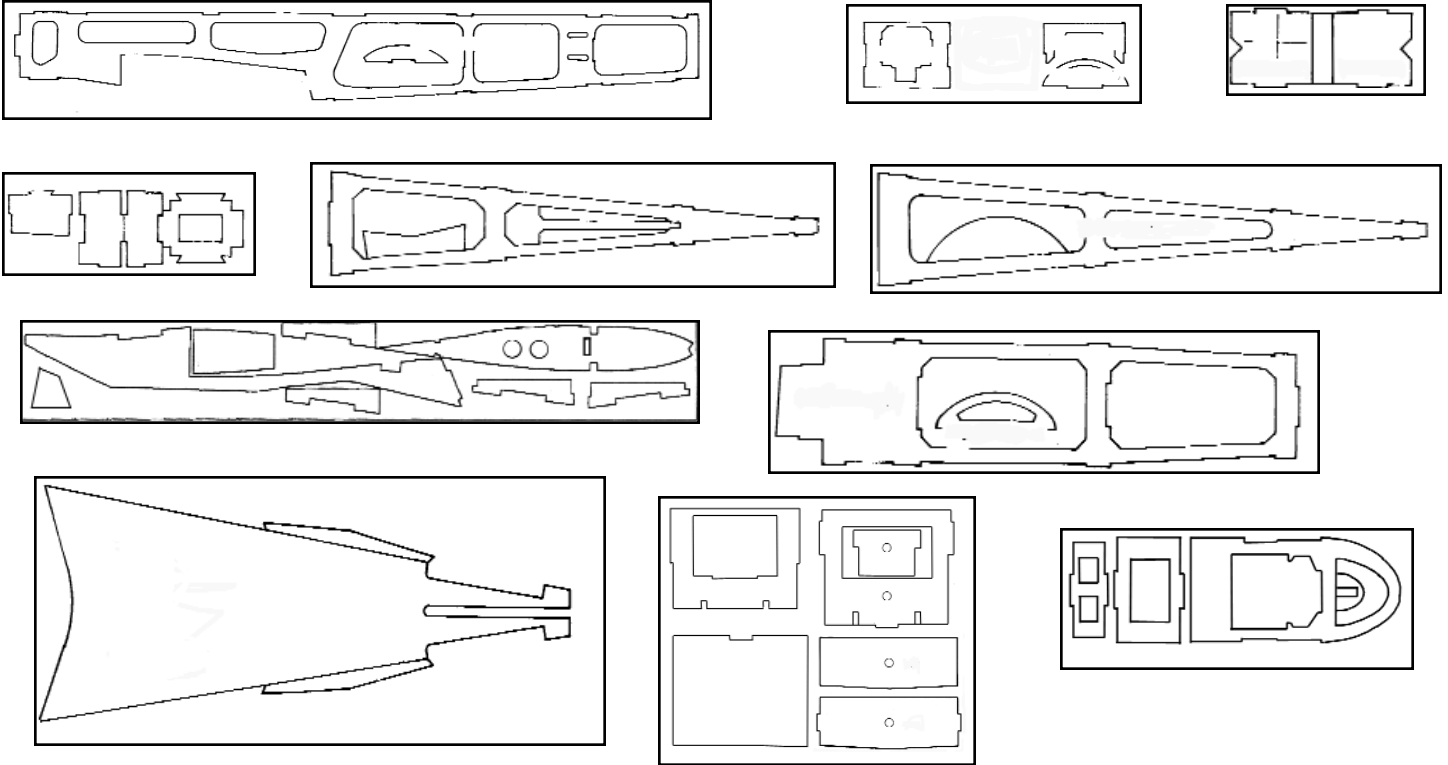

1. Gather the parts needed to construct the fuselage.

- (2) D/C SHT.6728 LITE PLY PT. #3655  
FUSE. SIDE/COWL SIDE SUPPORT
- (1) D/C SHT. 6729 LITE PLY PT. #3651  
FORMER "A", "C" & "D"
- (1) D/C SHT. 6704 LITE PLY PT. #3663  
FORMER "F","G","H" & "J"
- (1) D/C SHT.6724 LITE PLY PT. #3659  
CONTAINS:  
(1) FUEL TANK TRAY  
(1) MOTOR MOUNT BOTTOM  
(1) LEFT MOTOR MOUNT SIDE  
(1) RIGHT MOTOR MOUNT SIDE
- (1) D/C SHT. 6706 BIRCH PLY PT. #3665  
CONTAINS:  
(1) FIREWALL FRONT  
(1) FIREWALL AFT
- (1) D/C SHT. 6707 LITE PLY PT. #3666  
CONTAINS:  
(1) TOP AFT  
(1) WIND STOP  
(2) TURTLE-DECK BACK-UP
- (1) D/C SHT. 6708 PT. #3667  
CONTAINS:  
(1) BOTTOM AFT  
(1) COWL SUPPORT-TOP
- (1) D/C SHT.6709 LITE PLY PT. #3668  
CONTAINS:  
(1) TOP-FRONT  
(1) FORMER "E"
- (1) D/C SHT. 6710 BIRCH PLY PT. #3669  
(1) TURTLEDECK
- (2) L/C SHT. 6731 LITE PLY PT. #3653  
CONTAINS:  
(1) WING SADDLE DOUBLER

- (1) L/C SHT. 6732 LITE PLY PT. # 3652  
CONTAINS: (1) FORMER B  
(1) FORMER B2  
(1) LANDING GEAR PLATE
- (1) WING MOUNTING BLOCK PT. #3672  
7/16" TAPER x 5-1/8" BASS
- (1) FRONT TOP SHEET PT. #3673  
1/32 x 8 x 9-1/2" BIRCH PLY
- (3) GUSSET PT. #4217  
1/2" TRI x 8" Balsa
- (1) .078 x 13-5/8" THREADED ROD PT. #1281
- (2) ENGINE MOUNT PT. #1466
- (6) 6-32 BLIND NUTS PT. #1124
- (2) 6-32 x1" SOCKET HEAD SCREW PT. #1023
- (2) #6 FLAT WASHER PT. #1140
- (2) #6 x 3/4" O.D. FLAT WASHER PT. #1144
- (1) FUSELAGE PLAN PT. #2123

MARKING LINES FACING UP

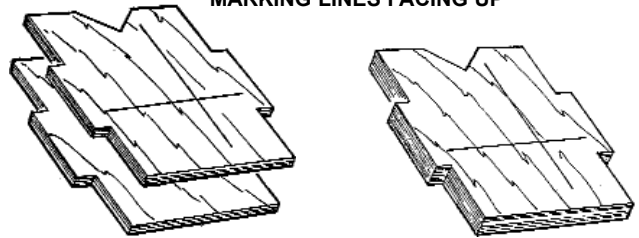

2.  Making sure the marking lines are facing out and that the perimeter is lined up, laminate the two 1/8" birch plywood FIREWALL parts with SUPER JET.

- Tape together and place under a weight until dry.

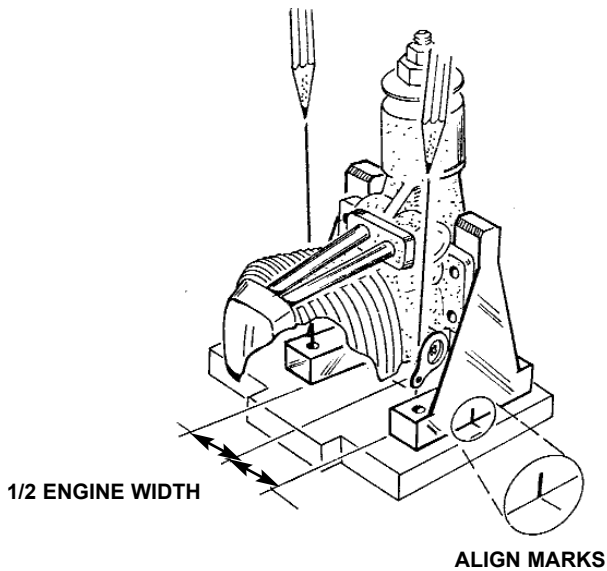

- When the firewall has thoroughly dried, tack-glue the motor you intend to use to the ENGINE MOUNTS.
  - Align the marks on the engine mounts with the vertical marking line on the firewall.
  - Center the engine mounts on the horizontal marking line, as shown, and mark all four hole locations.
  - Mark the location of the throttle pushrod exit in line with the throttle control.

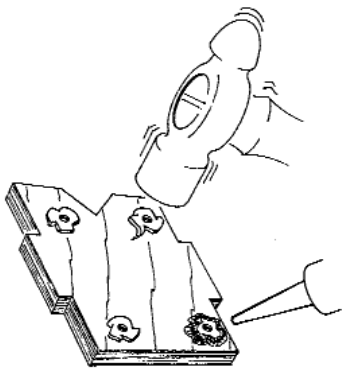

- Drill a 5/32" diameter hole at each hole location.
  - Flip the firewall over and insert four 6-32 BLIND NUTS. Seat them with a soft hammer blow.
  - Making sure that the glue does not get into the threads, coat the edges of each blind nut with CA glue. Then, set the firewall aside.

## TWO SERVO OPTION

**NOTE:** Flying the Sukhoi with one of the larger recommended engines will produce spectacular results. However, these larger 4-stroke engines generate a lot of vibration. Therefore, you may wish to install two elevator servos. If you choose this option, refer to the following instructions.

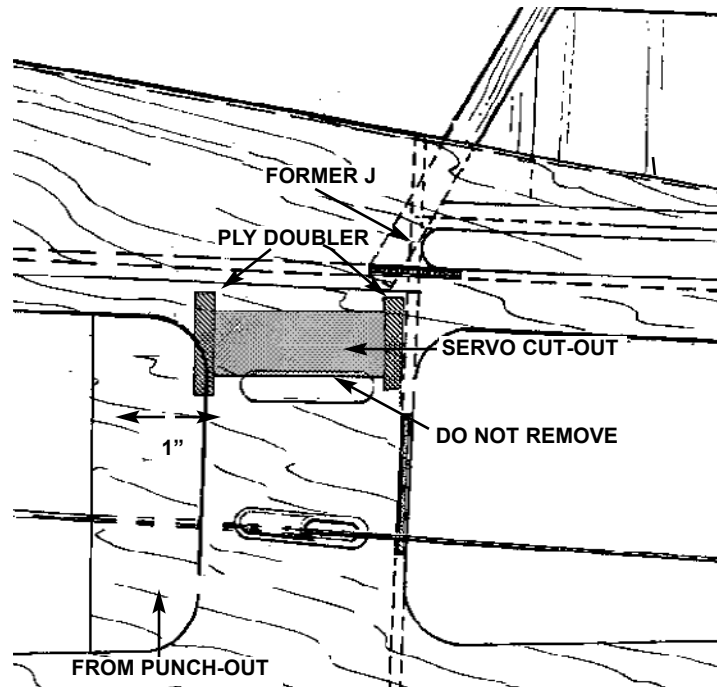

- Do not punch out the elevator exit. Instead, glue it permanently in place.
- Cut a hole for the servo on each side of the fuselage, as shown.
- Make two doublers from scrap 1/8 x 1/4 x 1-1/4" ply and glue the forward doubler to the INSIDE of the fuselage. Glue the rear doubler to the OUTSIDE of the fuselage. This helps to position the servo more parallel to the elevator pushrod.
- From the fuse side punch-out, cut off about a 1" piece from the end and glue this strip back into the fuse.
- When mounting the servos, it is essential that one of the servos be reversed. The easiest way to accomplish this is to use a special Y-harness that will reverse one servo from the other. Alternatively, "mix" your elevator channel into an extra channel in your radio, and then reverse to achieve proper direction. Consult your radio manual for details.
- Using the elevator pushrod wire supplied in the kit, trim to fit, making sure there are no bends. When adjusting throws, try to get both elevators to move equally.

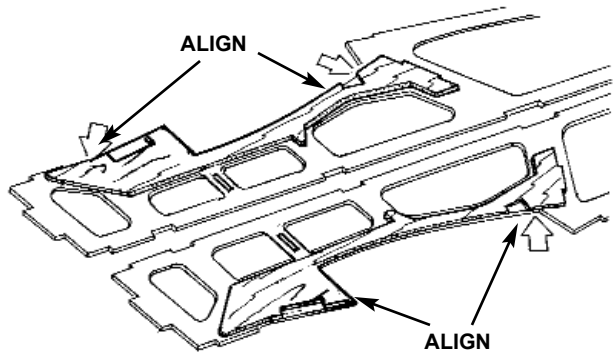

5.  Lay the FUSELAGE SIDES on a flat surface side-by-side, in a mirror-image configuration. This will ensure that you build a left and a right fuselage side.
  - Aligning the front and rear points for correct positioning, glue a WING SADDLE DOUBLER to each fuse side.

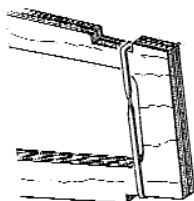

6.  With the doublers face-to-face, rubber band the fuse sides together at the rudderpost location.

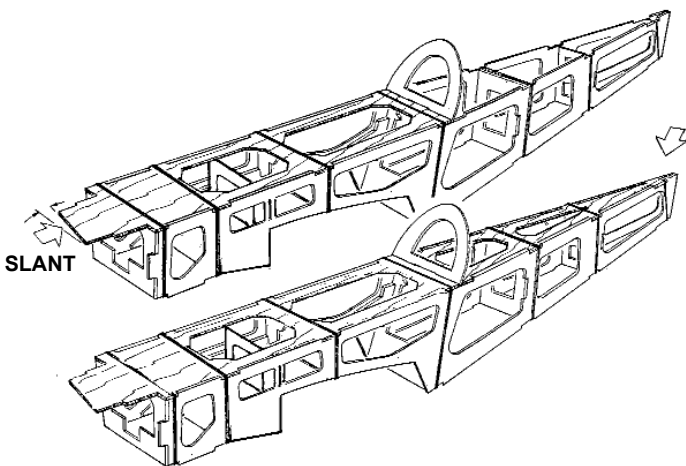

7.  Position, but **DO NOT GLUE**, FORMERS A, B, B2, C, F, G, and H. Use a rubber band at each former location to hold the fuselage together.
8.  Slide the TOP FRONT (note slant) and the TOP AFT under the rubber bands and into the alignment notches. **DO NOT GLUE.**

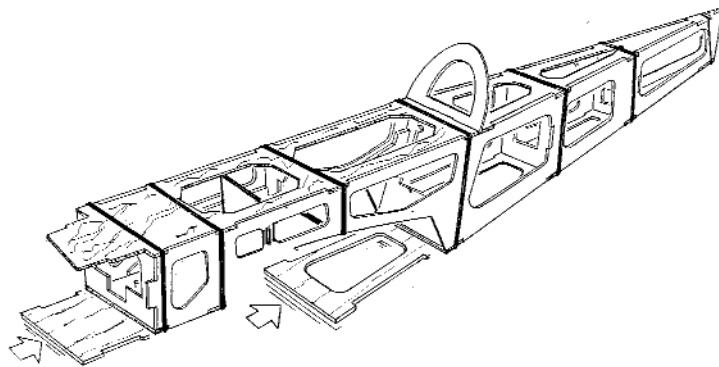

9.  Invert the fuse and slide the BOTTOM AFT and the LANDING GEAR COVER PLATE into the notches provided. Again, **DO NOT GLUE.**

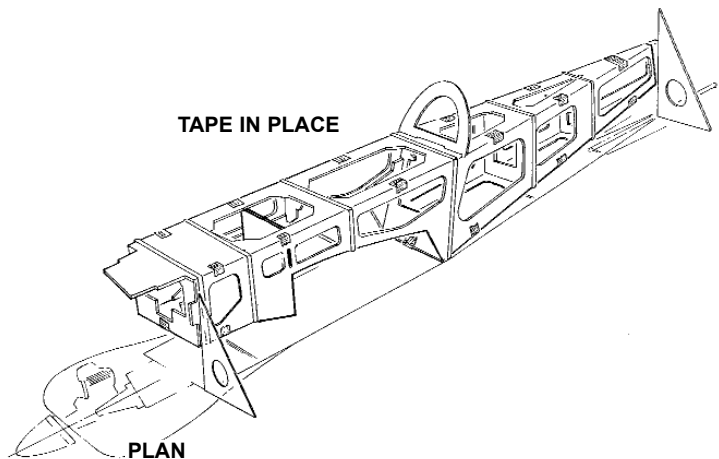

10.  Position the fuselage assembly over the bottom view of the plan and check the alignment.
  - Secure the assembly with small pieces of masking tape, as shown.

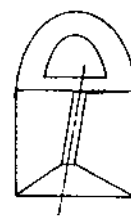
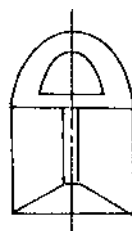

- LIKE THIS**                      **NOT LIKE THIS**
- Sight check along the fuselage to ensure that the fuse is straight, not twisted.



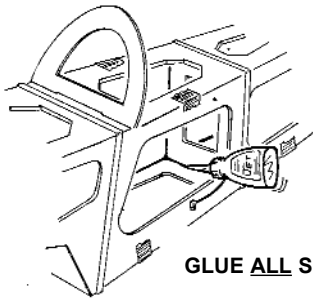

**GLUE ALL SEAMS**

11. □ When the fuselage is perfectly aligned, glue all of the areas where the sides, top, bottom, and formers join.

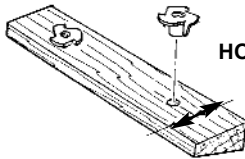

**HOLE IS CENTERED**

12. □ Insert the remaining 6-32 blind nuts into the pre-drilled holes in the WING MOUNTING BLOCK.

**NOTE:** Make sure the blind nuts are inserted into the side of the mounting block where the holes are centered.

- Tap with a hammer to ensure the spurs are fully set into the wood.

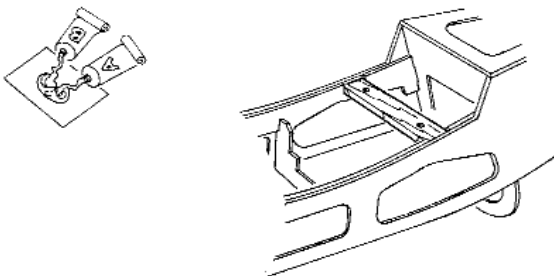

13. □ With the blind nuts on the inside the fuse, place the mounting block into the cut-outs in the wing saddle doubler and the fuselage sides. Trim, if necessary, to achieve a good fit. Then, using epoxy, glue in place.

**NOTE: THIS IS A HIGH STRESS AREA. THE BETTER THE MOUNTING BLOCK FITS INTO THE SOCKET, THE STRONGER THE JOINT WILL BE.**

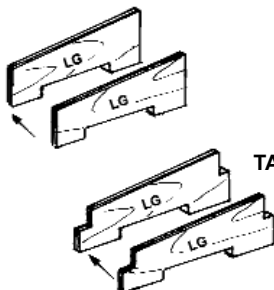

**TABBED DOUBLERS**

14. □ Form four 2-ply assemblies from the four LANDING GEAR DOUBLERS.

- When the laminated assemblies are dry, test fit in position. The assemblies with the tabs fit at

the slotted locations between Former B and Former B2. The assemblies without the tabs go along the fuse sides.

- Epoxy securely in place.

**UNTABBED DOUBLERS**

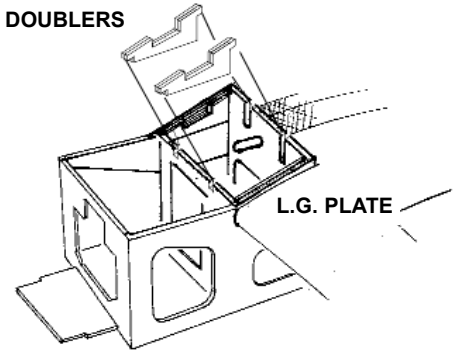

**L.G. PLATE**

15. □ Epoxy the 1/4 x 2-1/4 x 5-11/16" ply landing gear plate between the fuse sides and into landing gear doublers.

Now get the wing, which will be needed for the next few steps.

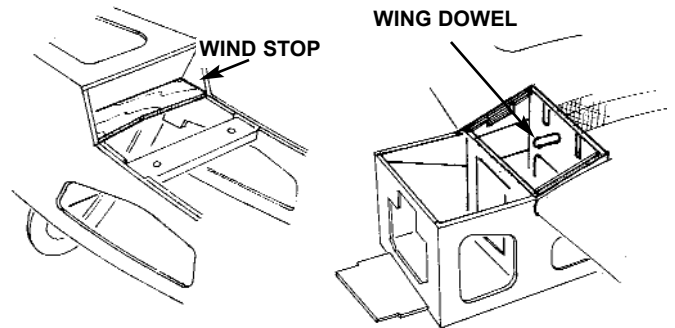

**WIND STOP**

**WING DOWEL**

16. □ Place the fuselage, bottom up, on a flat surface.

- Glue the WIND STOP to the fuse sides and the doublers.

- Insert the wing dowel through the slightly oversized hole in Former B2. Slide the wing as far forward as it will go. Make sure that the wing fits tightly all along the wing saddle.

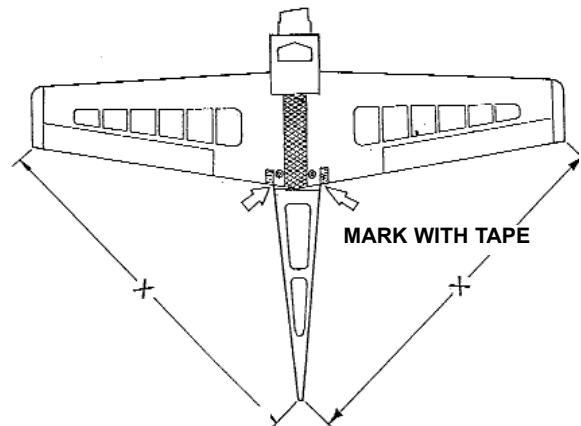

**MARK WITH TAPE**

17. □ True the wing to the fuselage by adjusting the distance from the wing-tip to the tail until both dimensions are equal. Mark the wing for reference and tape in place.

**WING DOWEL SCAB PLATE**

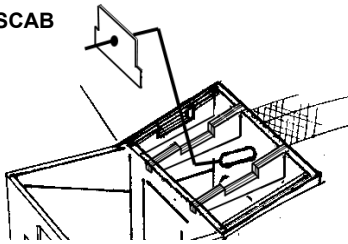

- ❑ Being careful not to get glue on the dowel, glue the WING DOWEL SCAB PLATE over the wing dowel and to the front side of Former B2.
- ❑ Glue the LANDING GEAR COVER PLATE in position.

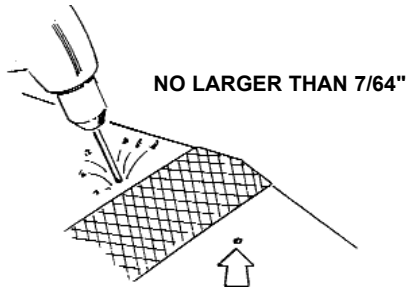

- ❑ Make sure the holes are aligned. Then, **taking care to not get glue in the hole or on the screw**, apply CA glue to the bottom of the wing bolt pad and glue to the wing.

NOTE: *Brush On™ Super Jet* is excellent for this job.

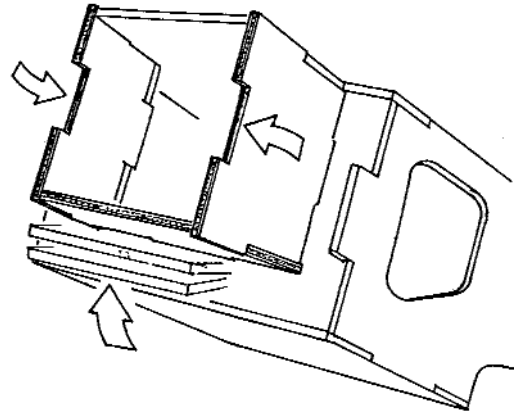

21. ❑ Install the MOTOR MOUNT BOTTOM and both MOTOR MOUNT SIDES to the fuse, as shown. Use a generous amount of glue, as this is a high stress area.

18. ❑ Carefully turn the wing/fuselage assembly to an upright position.
- ❑ Cut the threaded segment from one of the .078 x 13-5/8" threaded rods and use as a drill bit. Don't use anything larger than 7/64" (.109/2.7mm) in diameter.
- ❑ Using the blind nuts as locators, drill a pilot hole through the bottom of the wing.
- ❑ Remove the wing from the fuselage and, using the pilot hole as a guide,
19. ❑ Test bolt the wing to the fuse and, following the procedure used before, again check the alignment by making sure the dimensions from wing tip to tail are still equal on each side of the model.

1/14" BACK FROM FRONT EDGE

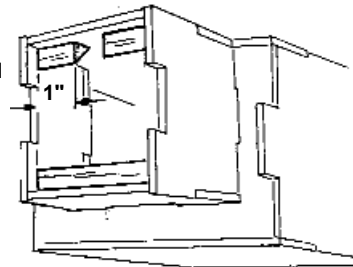

22. ❑ Using the 1/2" balsa tri stock, trim and fit the FIREWALL GUSSETS in place. They should be located 1/4" back from the edge of the motor mount, as shown.

"V" NOTCH AT TOP

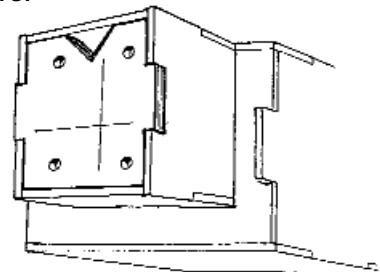

5/32" HOLE

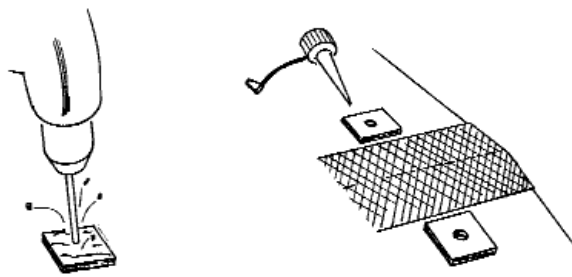

20. ❑ Drill a 5/32" hole at the centermark on each WING BOLT PAD.
- ❑ Place each pad on a 6/32 x 1" socket head screw and screw part way down into the blind nut.

23. ❑ With the blind nuts to the inside and the V-notch on top, epoxy the FIREWALL into the fuse. Use plenty of epoxy and let dry thoroughly.

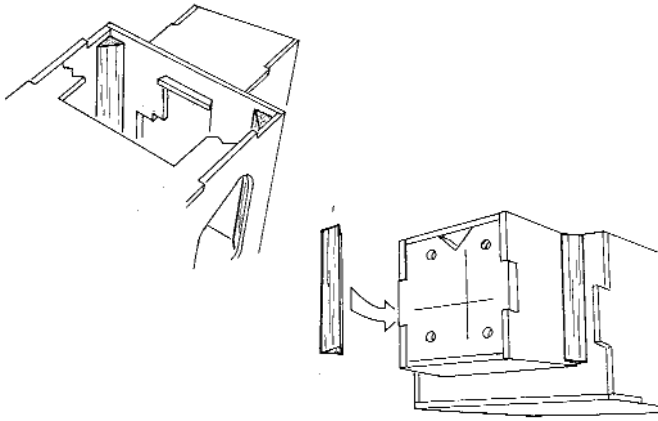

24. □ Trim and glue the remaining firewall gussets in place, as shown.

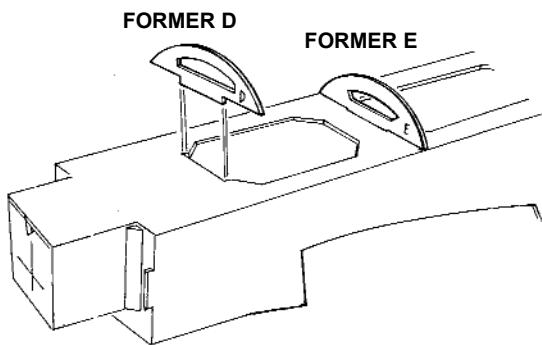

25. □ Glue FORMER D and FORMER E into the notches in the fuselage top.

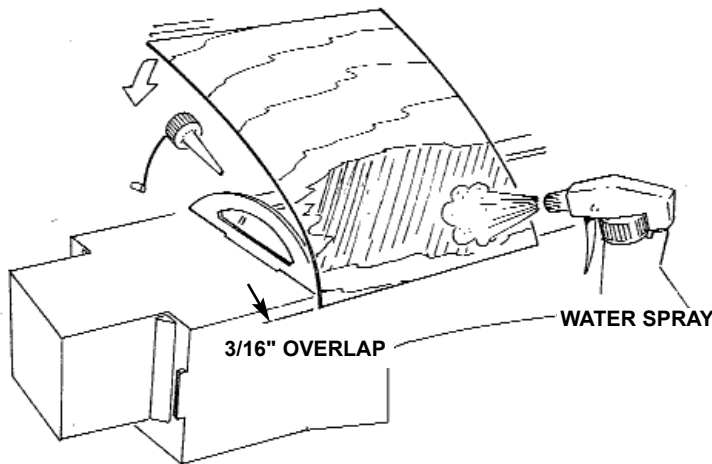

26. □ Overlapping the side 3/16", as shown, glue one edge of the 1/32" ply FRONT TOP SHEET to the fuselage.
- When the glue is dry, use a spray bottle to soak the sheet with water. Then **SLOWLY** roll the sheeting to the opposite side of the fuse, gluing to the formers as you go.

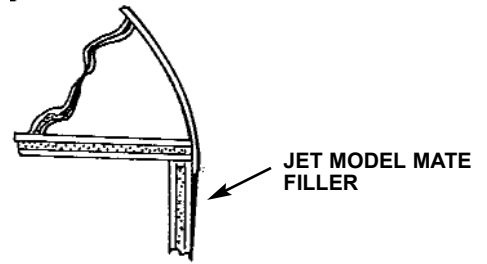

- Bevel-sand the plywood edge at the fuselage overlap.
- Fill the joint area with JET MODEL MATE™ and sand smooth.

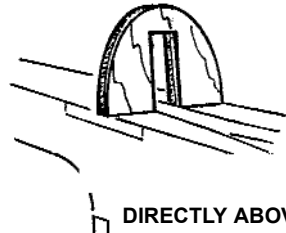

27. □ Glue FORMER J directly over FORMER H.

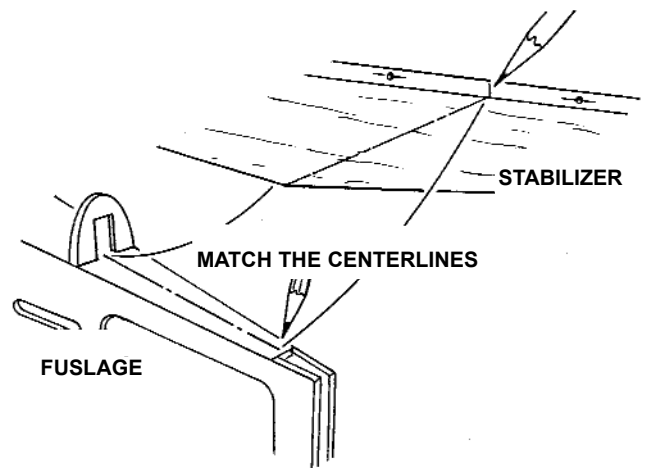

28. □ Mark the centerline onto the horizontal stabilizer and onto the stab platform on the fuselage.

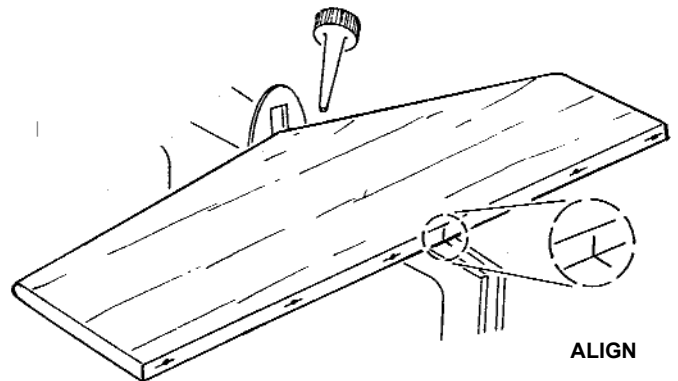

- Position the stab on the stab platform, making sure to locate it on the centerlines and against former J.
- Using epoxy, glue the stab to the stab platform.

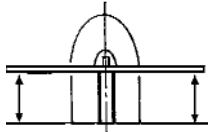

LIKE THIS

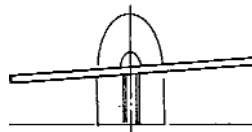

NOT LIKE THIS

- ❑ Before the glue has set and with the fuse sitting flat on the work surface, check to make certain the stab is parallel to the building board.

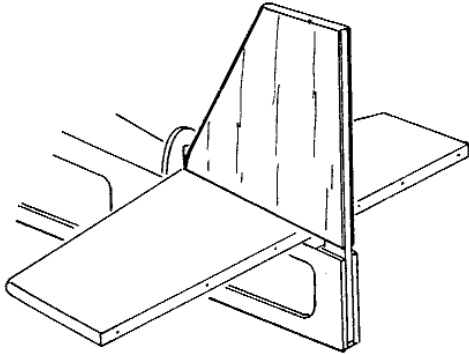

29. ❑ Insert the vertical fin L.E. into the slot in Former J and slide the rudder post into the fuselage.
- ❑ Check to make sure the fin is at a 90° angle to the stab and then glue in place.

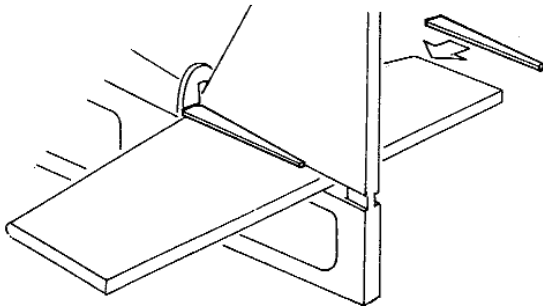

- ❑ Glue the two TURTLEDECK BACK-UPS, as shown.

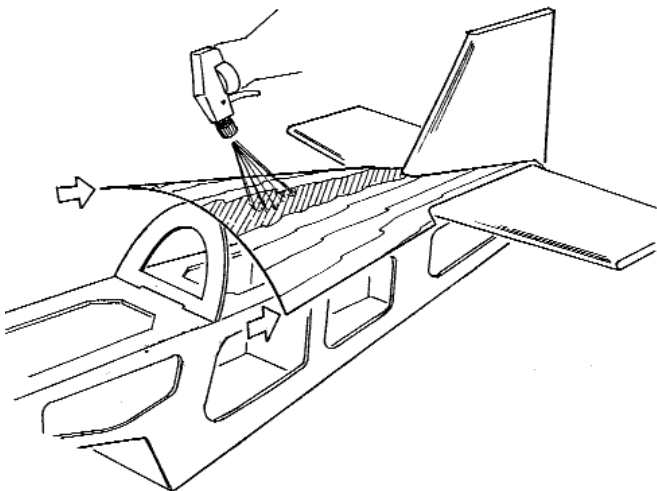

30. ❑ Slide the 1/32" ply TURTLEDECK back around the fin.
- ❑ Again using the spray bottle and water, soak the top center of the turtledeck.

- ❑ **SLOWLY** wrap the plywood around the formers and down onto the fuselage sides.
- ❑ Check the fit and trim, if necessary.

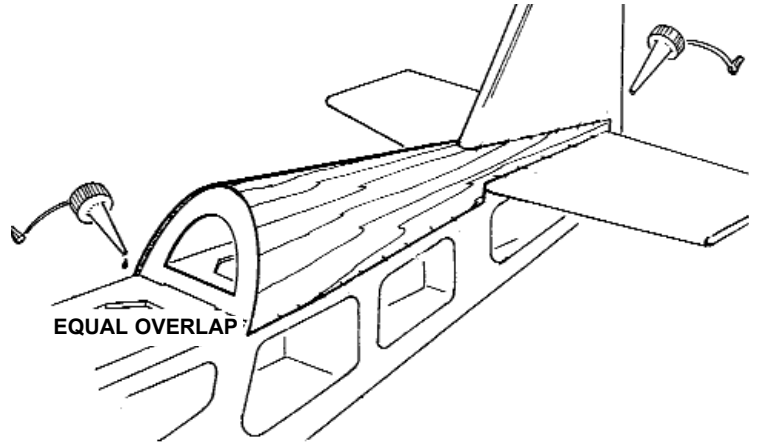

31. ❑ When satisfied with the fit, apply glue to the formers, fuselage, fin and stab.
- ❑ Immediately wrap the turtledeck down onto the fuse and tape in place until dry.

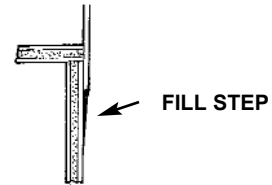

- ❑ When thoroughly dry, bevel-sand the plywood edge where it overlaps the fuse. Also sand the turtledeck front flush with Former F.
- ❑ As with the top front sheeting, fill the step with JET Model Mate™ and sand smooth.

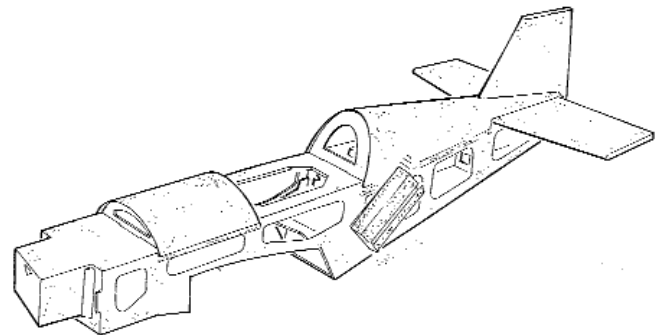

32. ❑ Go over the fuselage, sanding all seams and joints.
- ❑ Then, finish sand the entire fuse assembly with **fine grit** sandpaper to provide a smooth surface for covering.

THIS COMPLETES THE BUILDING PORTION OF YOUR MODEL. MAKE SURE ALL PARTS ARE WELL-SANDED AND ALL NICKS ARE FILLED. THEN PROCEED TO THE "GENERAL INFORMATION BOOK", COVERING SECTION. AFTER COVERING THE MODEL, RETURN TO THE FINISHING SECTION IN THIS BOOK AND CONTINUE.

# FINISHING THE MODEL

## CANOPY INSTALLATION

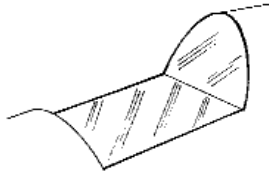

1.  You will need the canopy and paint or covering.
2.  Cover the cockpit interior with black or gray iron on film or paint, as preferred.

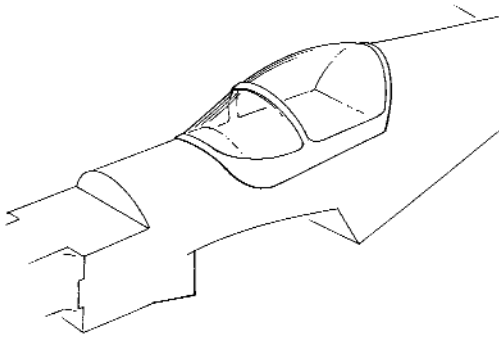

3.  Trim the canopy around the perimeter, along the trim line.
4.  Using epoxy or a clear canopy glue, glue the canopy overlap to the fuselage sides and around the front and back of the cockpit.

## FUEL TANK INSTALLATION

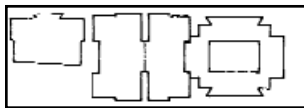

1.  Gather the following items:
 

(1) D/C SHT. 6724	PT. #3659
(1) TANK TRAY	
(1) FUEL TANK	NOT INCLUDED
(1) 12" LENGTH OF FUEL LINE	NOT INCLUDED
(2) #64 RUBBER BANDS	NOT INCLUDED
(1) FOAM PADDING	NOT INCLUDED

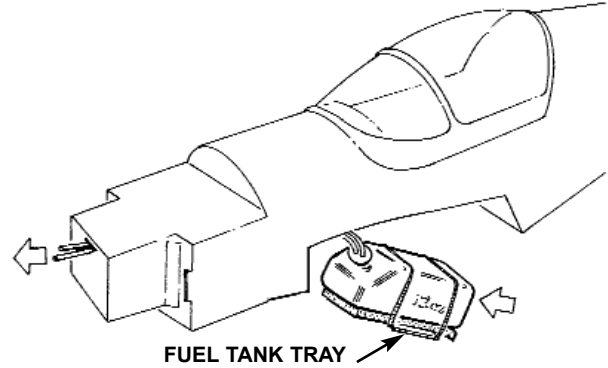

2.  Rubber band the foam pad and the fuel tank to the tank tray.
3.  Thread the fuel line through the "V" notch in the firewall and attach them to the tank.
  - Pull the line forward and glue the tank assembly onto the locating shoulders on Former A and Former B, inside the fuselage.
  - Connect the fuel lines when you mount the engine.

## TAILWHEEL ASSEMBLY

1.  Collect the following items:
 

(1) TAILWHEEL ASSEMBLY	PT. #5819
(1) ADJUSTABLE HORN BRACKET	PT. #1424
(2) #2 x 3/8" SHT. METAL SCREW	PT. #1084
(1) 1-1/4" TAILWHEEL	NOT INCLUDED
(2) CGP 3/32" WHEEL COLLAR	NOT INCLUDED

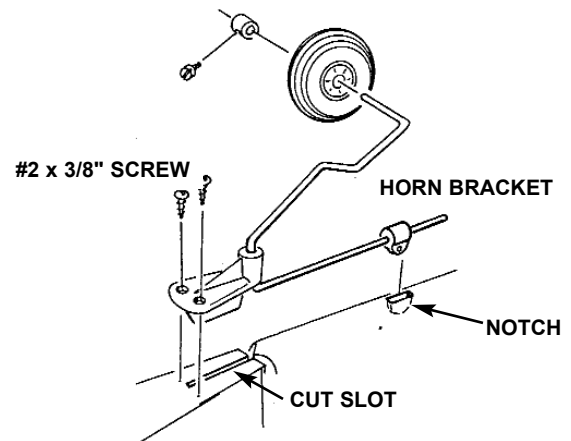

2.  Cut a narrow slot through the fuse bottom and secure the tailwheel brack assembly with the #2 x 3/8" screws.
3.  Notch the bottom of the rudder to mount the horn bracket.
  - Slide the bracket into the wire and glue into the notch. DO NOT GLUE BRACKET TO WIRE.
4.  Trim the wire and install tailwheel, as shown.

## CONTROL SURFACE/RADIO INSTALLATION

- ❑ If you did not do so immediately after covering the model, thin CA glue the hinges in place, permanently attaching the elevator to the stab and the rudder to the fin.

❑ Permanently install the ailerons on the wings.
- ❑ Referring to the GENERAL INFORMATION BOOK and to the specific details and guidelines that came with your radio system, install the radio, servos, and battery. A servo tray is provided in this kit; however, it may be necessary to modify it to suit your equipment.

## ELEVATOR PUSHROD INSTALLATION

- ❑ Collect the following items:

(1) 3/8" x 3/8" x 16" BASS PUSHROD	PT.#3674
(2) LONG CONTROL HORNS	PT.#1407
(4) 2-56 x 3/4" PAN HEAD SCREWS	PT.#1042
(3) SNAP LINKS	PT.#1405
(2) HOODED PUSHROD EXITS	PT.#1453
(1) .078 x 10" THREADED ROD	PT.#1272
(2) .078 x 13-5/8" THREADED ROD	PT.#1281

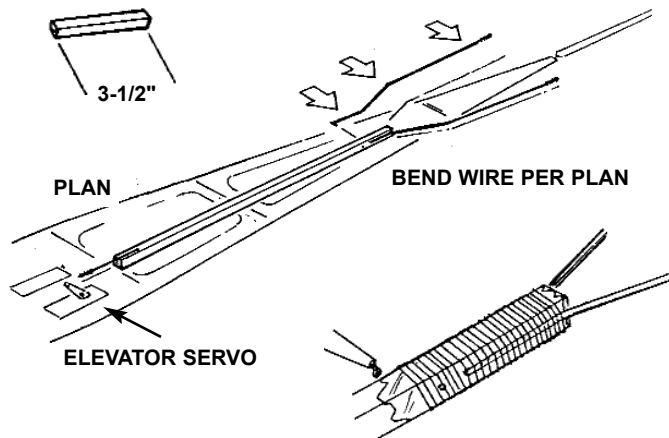

- ❑ Cut 3-1/2" off the end of the basswood pushrod. Set this piece aside, as it will be need for attaching the cowling and for elevating the rudder servo.
- ❑ Using the TOP VIEW of the fuse plan as a template, bend the two 13-5/8" threaded rods in the correct configuration.

❑ Glue the rods to the bass pushrod and wrap with a strong thread. Coat the thread with more glue.
- ❑ Referring to the plan, cut the 10" threaded rod to size. Attach to the other end of the bass pushrod, wrapping with string and coating with glue.

## ENGINE PUSHROD INSTALLATION

- Gather the necessary parts.

(4) 6-32 x 3/4" SOCKET HEAD SCREW	PT.#1022
(4) #6 M.S. WASHER	PT.#1140
(1) .034 I.D. x 18" NYLON TUBE	PT.#1657
(1) .030 x 34" CABLE	PT.#1289
(2) P.R. CONNECTOR BODY	PT.#1375
(2) 4-40 x 3/16" SOCKET HEAD SCREW	PT.#1003
(1) NYLON SNAP-NUT (6/set)	PT.#1461
(4) #6 x 3/4" SHT. METAL SCREW	PT.#1082
- ❑ Bolt the MOTOR MOUNTS to the firewall, using four 6-32 x 3/4" SOCKET HEAD SCREWS and #6 washers.

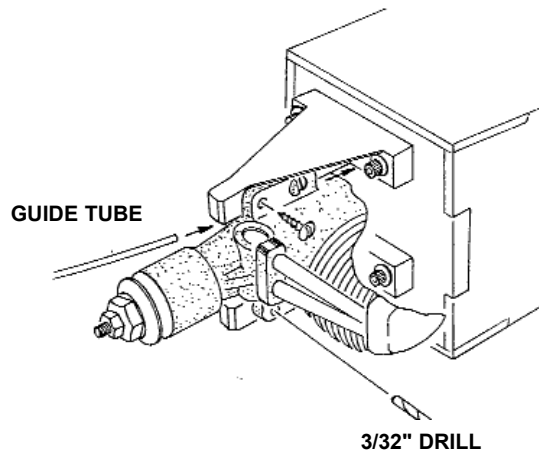

- ❑ Referring to the plan for correct engine/cowling position, screw the engine to the mounts with four #6 x 3/4" SHEET METAL SCREWS.
- ❑ Insert the NYLON GUIDE TUBE in the previously drilled hole in the firewall. Glue in place.

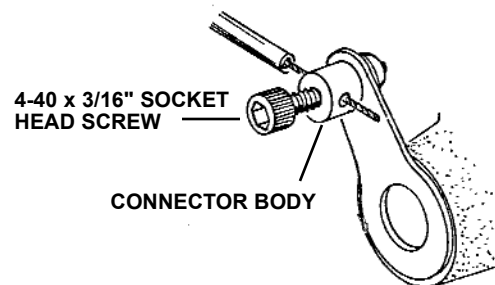

- ❑ Install the CONNECTOR BODIES to the engine throttle arm and the throttle servo arm. Secure with the NYLON SNAP-NUT.
- ❑ Thread the .030 x 34" CABLE through the nylon tube and into the connector bodies.

❑ With the servo at low motor position, and the carburetor closed, lock both ends of the cable with two 4-40 x 3/16" SOCKET HEAD SCREWS.
- ❑ Attach the fuel lines and install the muffler.

## AILERON SERVO CONNECTION

1. Collect the following items:
 

(4) #2 x 5/16" SHT. METAL SCREWS	PT.#1086
(2) .078 x 10" THREADED ROD	PT.#1272
(2) SNAP LINKS	PT.#1405
(2) LONG CONTROL HORNS	PT.#1407
(2) SERVOS	NOT INCLUDED
(2) 18" SERVO EXTENSIONS	NOT INCLUDED
2.  Install the aileron servos, if you have not already done so.

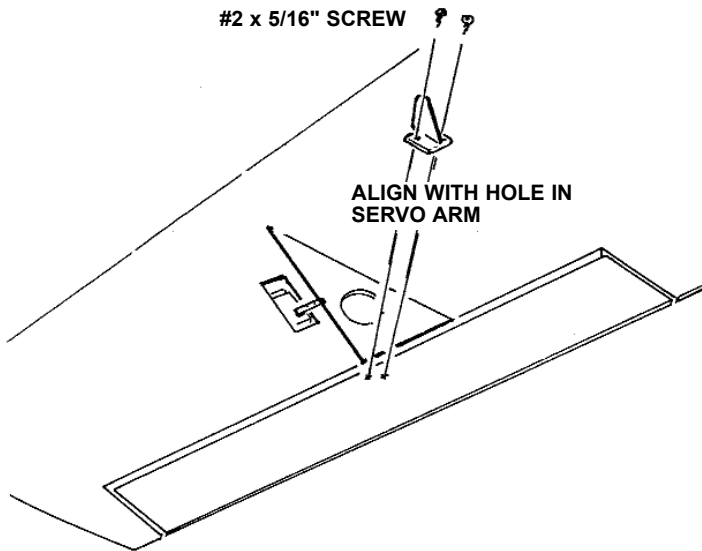

3.  Lay the triangle along the hinge line and over the last hole on the servo arm to locate the control horn.
  - Attach the control horns by screwing two #2 x 3/8" screws into the plywood back-up inside the ailerons.

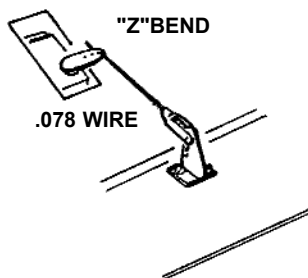

4.  With the ailerons and the servos in the neutral position, connect the pushrods.

## LANDING GEAR INSTALLATION

1.  Collect the following items:
 

(1) FORMED ALUMINUM GEAR	PT.# 1367
(2) THREADED AXLE	PT.# 1369
(4) #6 x 3/4" SHT. METAL SCREW	PT. #1082
(4) #6 WASHER	PT. #1140
(2) 3-1/2" WHEEL	(NOT INCLUDED)
(4) C.G.P 3/16" WHEEL COLLAR	(NOT INCLUDED)

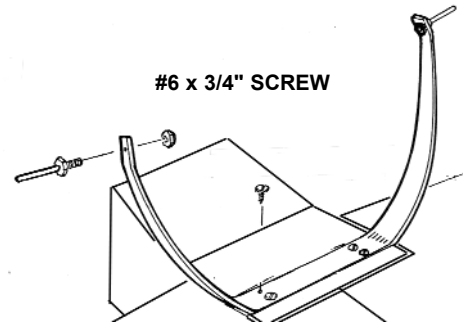

2.  Mark the centerpoint of the landing gear cover plate and the formed LANDING GEAR, making sure they are aligned.
3.  Using four #6 x 3/4" sheet metal screws, permanently mount the landing gear through the cover plate into the 1/4" ply landing gear mount.
4.  Bolt the AXLES to the landing gear and install the wheels.

## RUDDER CABLE INSTALLATION

### NOTE

The SUKHOI uses a pull-pull system. Therefore, the rudder servo must be located as shown on the plan to ensure the correct cable alignment with the cable exits. This feature was designed into the fixtured placement of the servo tray supplied in this kit. If you decide not to use the tray, make sure that you place the servo as shown on the plan.

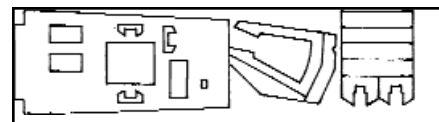

1.  Collect the following items:
 

(1) D/C SHT. 6712 PLY CONTAINS RADIO TRAY	PT. #3671
(2) .030 x 34" CABLES	PT.#1289
(4) THREADED COUPLERS	PT.#1192
(2) LONG CONTROL HORNS	PT.#1407
(2) 2-56 x 3/4" PAN HEAD SCREWS	PT.#1042
(4) SNAP LINKS	PT.#1405
(2) HOODED P.R. EXITS	PT.#1453
(1) 3/8" SQ. x 2" BASS CUT FROM PT.#3674	

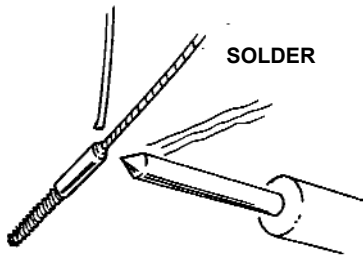

position, attach and adjust the cables until the rudder is centered.

NOTE: Cables need only be tight enough to eliminate slack.

2.  Solder a threaded coupler to one end of each cable.
- Lay the cable over the plan and cut to length.
- Solder a threaded coupler to the cut end of each cable.
3.  Glue the hooded exits to the fuselage and thread the cable assemblies from the rudder servo opening to the control horns.

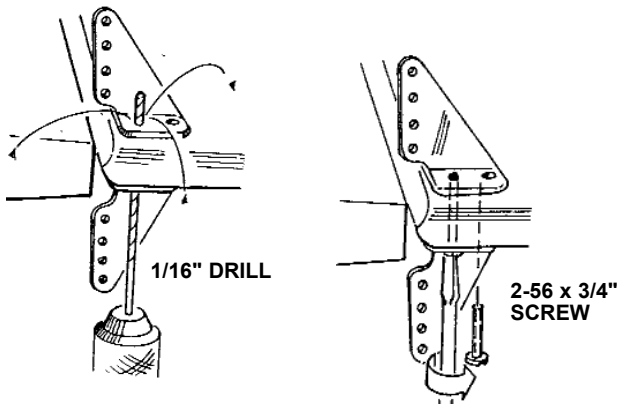

4.  Install a CONTROL HORN on each side of the rudder, directly opposite from one another.
- Drill two 1/16" holes into one of the horn and thread the two 2-56 screws into the horn.
5.  Thread the SNAP LINKS onto the threaded couplers and attach the links onto the rudder control horns.

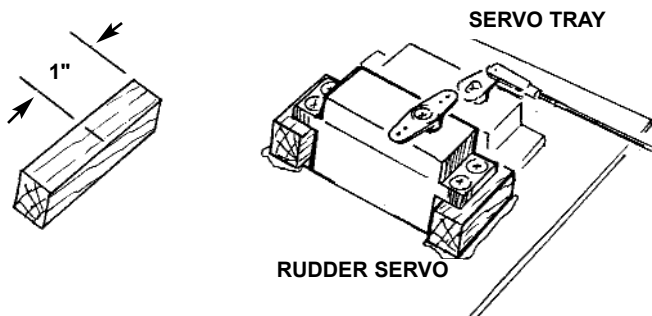

5.  Cut the remaining 3/8 sq. piece of bass from the elevator pushrod into a 2" length. Then, cut this piece into two equal pieces.
- Glue the two small blocks to the servo tray to raise the rudder servo, as shown on the plan.
- Mount the servo (a ball-bearing servo is recommended) and, with the servo in the neutral



# Assembling The Engine Cowling & Belly Pan

1.  Gather the necessary parts.
 

(2) FUSE. SIDE/COWL SIDE SUPPORT	(LITE PLY)
	PT.#3660 D/C SHT.6701
(1) COWL SUPPORT-TOP	(LITE PLY)
	PT.#3667 D/C SHT.6708
(1) LEFT COWL SIDE	PT.#1558
(1) RIGHT COWL SIDE	PT.#1559
(1) COWL FRONT	PT.#1560
(1) COWL JOINER STRIP	PT.#1666
(1) BELLY PAN	PT.#1571
(9) 4-40 BLIND NUTS	PT.#1125
(9) 4-40 x 3/8" SOCKET HEAD BOLTS	PT.#1005
(9) #4 FLAT WASHER	PT.#1139
(1) 3/8" sq/ x1-1/2" BASS	
CUT FROM ELEVATOR PUSHROD	PT. #3674



6701

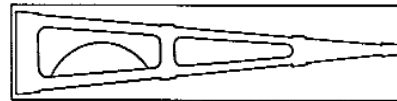

6708

2.  Carefully cut the COWL SIDES and COWL FRONT along the scribe lines around the perimeter. Sand the edges straight along the top and bottom seam line.

Cut out the center of the cowl front.

3.  Glue the front piece onto one of the sides.

Always sand the gluing surfaces prior to gluing.

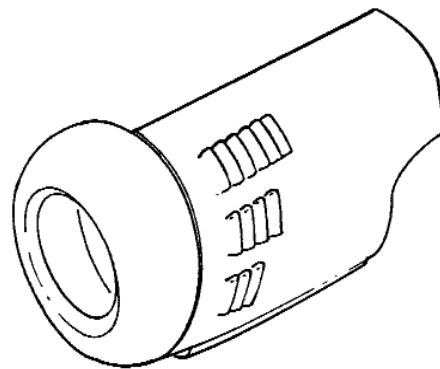

4.  Glue the JOINER STRIP to the top and bottom seam, leaving half of the strip width exposed to allow the other cowl half gluing surface.

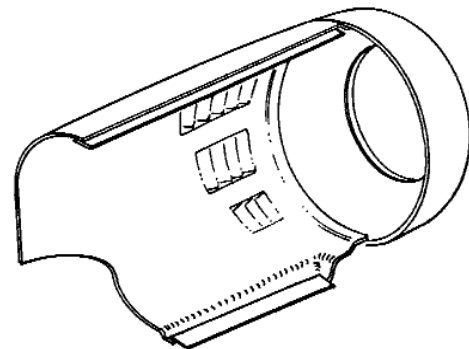

5.  Glue the remaining cowl side to the front piece and onto the joiner strip. Fit all the seams as tight as possible, in order to eliminate the need for excessive filling and sanding later.

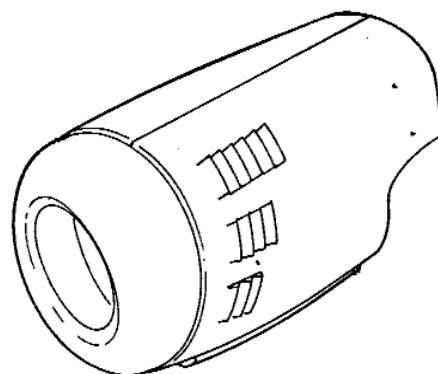

6.  Fill the seams with Model Magic and sand smooth.

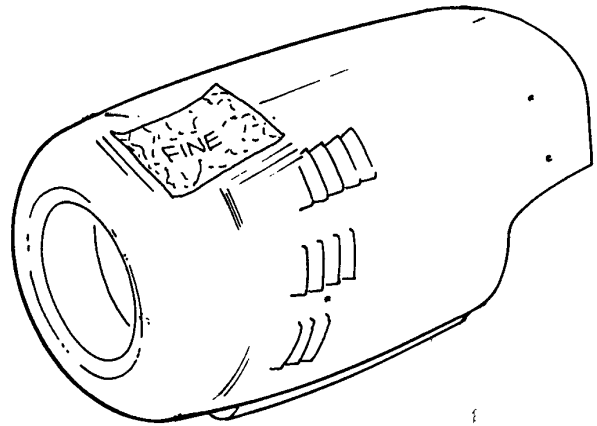

7.  Cut the BELLY PAN on the scribe line around the perimeter and sand the edges smooth.
- Paint the parts, using any of the following paints: BLACK BARON, Petit HOBBY POXY, K & B EPOXY, or Pactra FORMULA "U".

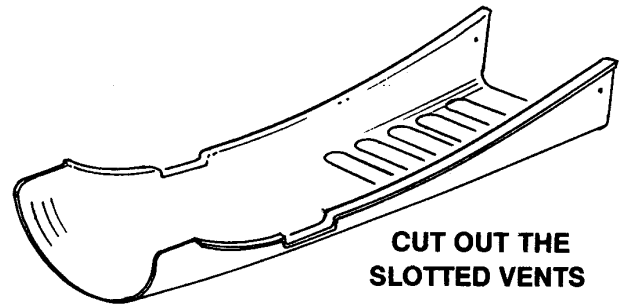

8.  Glue the COWL SIDE SUPPORTS to the sides of the fuselage. Glue the COWL SUPPORT-TOP to the fuselage and to the side supports

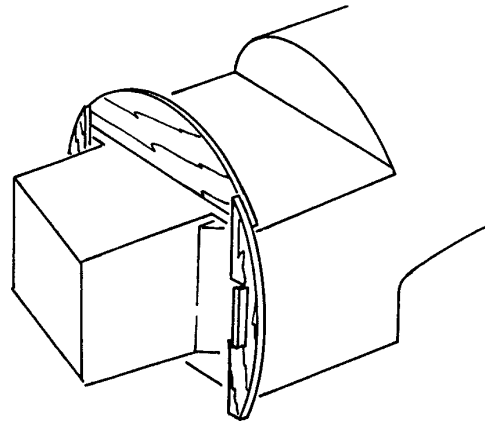

9.  Cut three 1/2" lengths from the 3/8" sq. x 3-1/2" basswood pushrod segment (removed from the elevator pushrod). Save the remaining 2" piece for the rudder servo riser.
- Take two of the dihedral tip supports and cut the three platform segments, as shown.
- Glue a 3/8" sq. x 1/2" bass block flush with one end of all the platform segments, creating three brackets.

**TRIM SIDE SUPPORT FLUSH IF NEEDED**

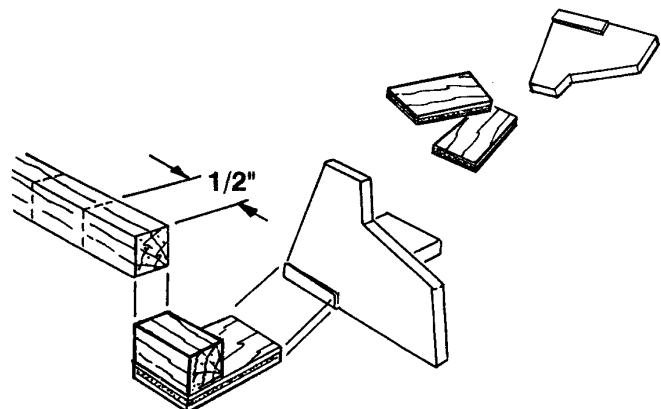

- Using the plan for location, glue the brackets onto the cowl supports, as shown.

**SEE THE PLAN FOR LOCATION**

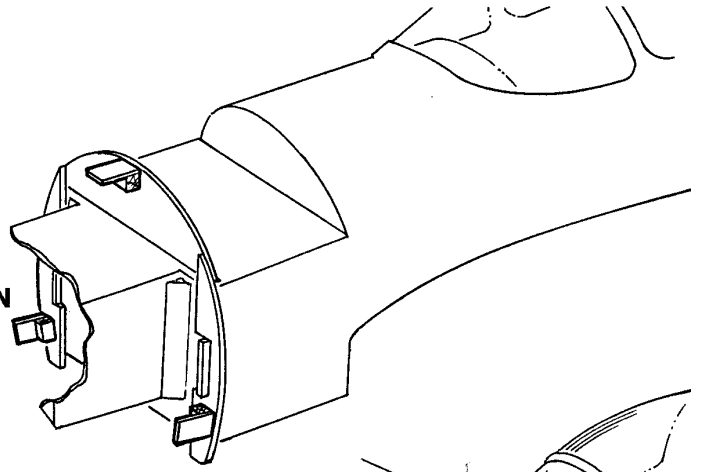

Reinstall the wing for the next few steps.

- Slide the cowl over the engine and onto the fuselage.
- Install the prop and spinner to the engine.
- Position the cowl onto the top of the wing and against the L.E. Check the fit around the fuselage and the wing. Trim to fit if necessary.
- Make sure that the spinner is concentric with the cowl, when viewed from the front. Check that there is prop clearance with the front of the cowl.

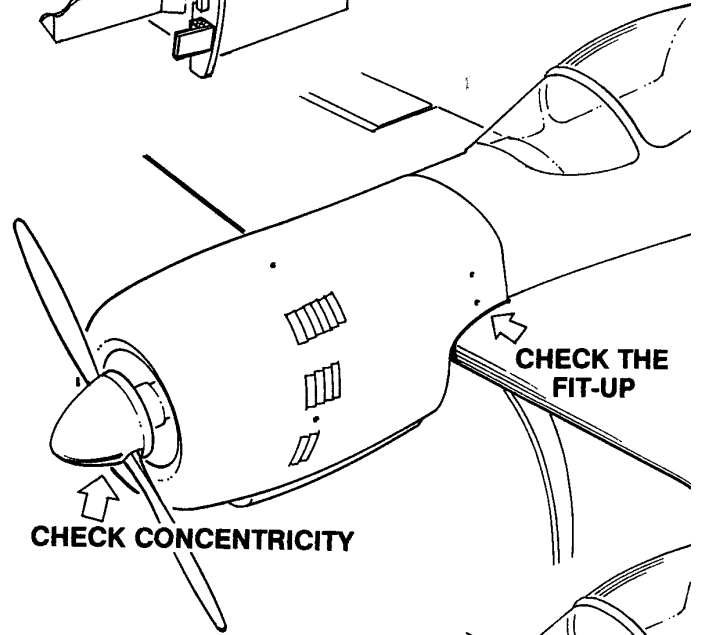

- Drill seven 3/32" holes through the cowl and fuselage, at the dimples on the cowl.

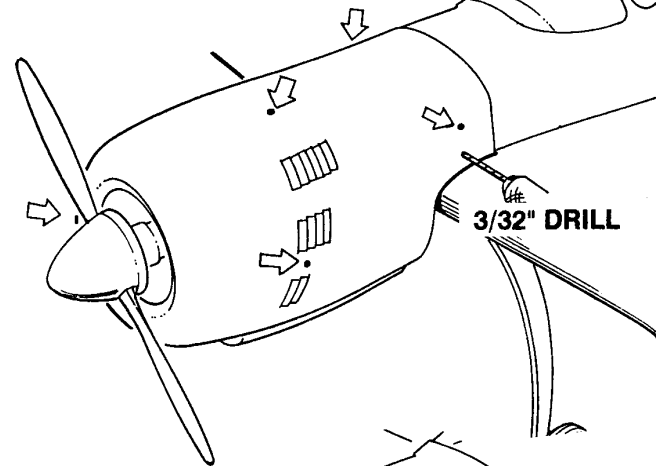

- Remove the cowl and drill a 1/8" hole, using the 3/32" hole as a pilot at each location.
- Press a 4-40 BLIND NUT into the back side of each hole.

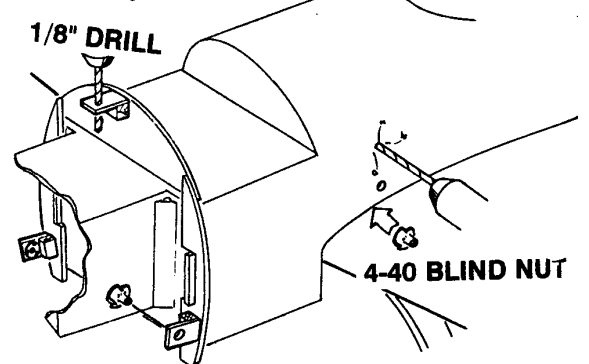

- Use 80 grit sandpaper to roughen the inside of the cowl at each hole. Using **SLOW JET**, glue a 2" square of nylon over each hole for reinforcement.

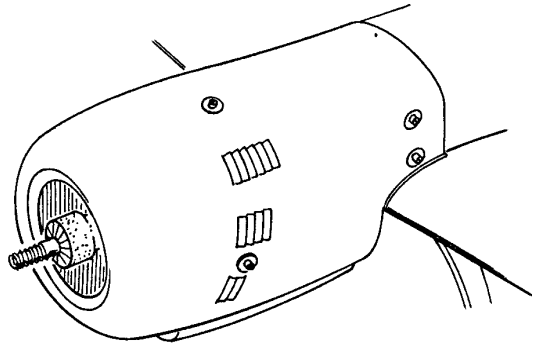

- Reinstall the cowl and secure with seven 4-40 x 3/8" SOCKET HEAD BOLTS and #4 WASHERS.

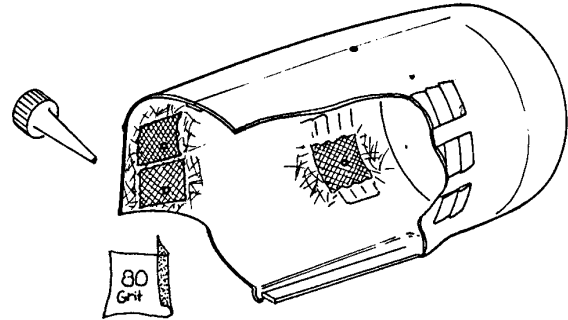

- Fit the belly pan in behind the back of the cowl, and down over the fuselage.

- Drill a 3/32" hole through the pan and fuselage at the two dimple locations.

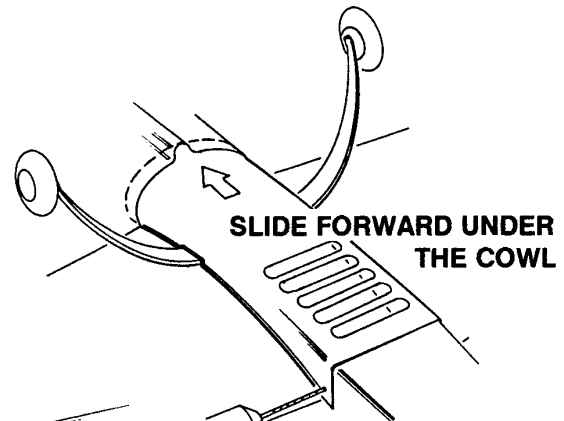

- Remove the pan and drill a 1/8" hole through the fuselage and press in the 4-40 blind nuts.

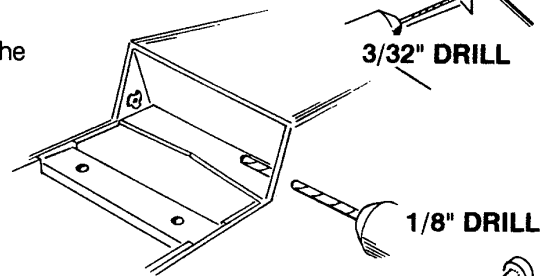

- Use 80 grit sandpaper to roughen the inside of the cowl at each hole. Using **SLOW JET**, glue a 2" square of nylon over each hole for reinforcement.

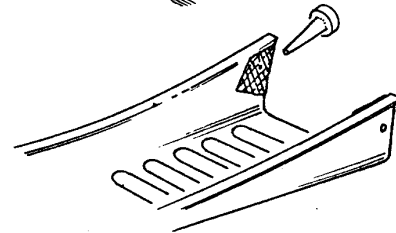

- Reinstall the belly pan and secure, using two 4-40 x 3/8" SOCKET HEAD BOLTS and #4 WASHERS.

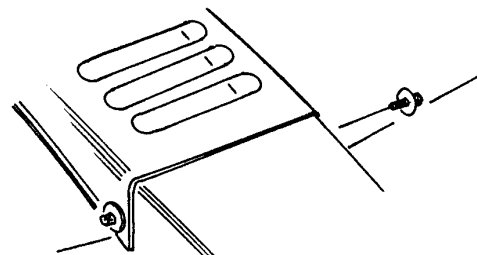

# SETTING CONTROL SURFACE TRAVEL

Use the control surface travel gauges to correctly set up the surface deflections. The gauges provide you with two settings: a gentle response setting and a more aerobatic setting. Even if you are an experienced pilot, we encourage you to start out at the gentle setting and then move to the aerobatic mode after you become more familiar with the characteristics of this aircraft.

## AILERON GAUGE

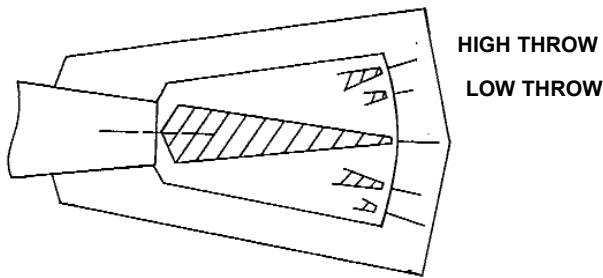

- Place the gauge anywhere along the wing. Align the center of the aileron to the mark in the neutral position.
  - With the control stick full left and full right, match the center of the aileron to the mark.
- Adjust the horn bracket up or down along the hole selection to achieve the correct travel setting.

NOTE: This is a good time to make sure the control surfaces are responding correctly. You would not want to correct a left bank with *more* left, so check it now!

## ELEVATOR GAUGE

### UP ELEVATOR

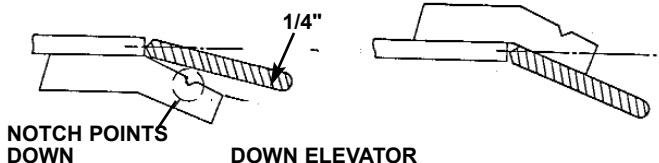
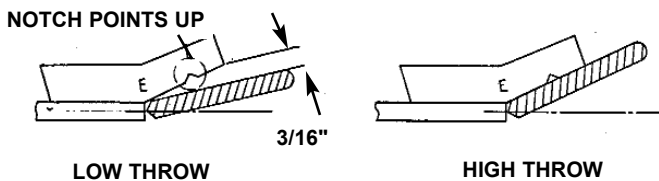

- Place the elevator gauge anywhere along the elevator hinge line.
- Adjust the servo arm hole along with the control horn hole to achieve the desired setting. Check each elevator.

## RUDDER GAUGE

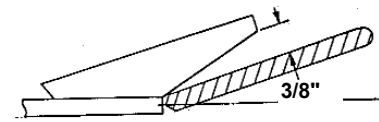

LOW THROW

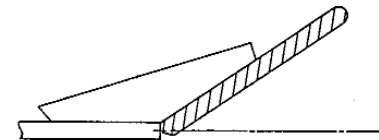

HIGH THROW

### LEFT AND RIGHT RUDDER

- Position the rudder gauge at the top of the fin at the hinge line. Follow the same procedure used for the elevator to achieve the desired travel.

# FLYING THE SUKHOI

The CARL GOLDBERG PRODUCTS SU-26 probably flies more like its full-size cousin than any other kit on the market. We have designed it deliberately to make unlimited aerobatics practical for the average pilot. In fact, if you are comfortable with a low-wing sport aircraft, you should have no difficulty in being successful with the GOLDBERG SUKHOI. Take great care in building and setting up your aircraft and the SU-26 will reward you with many hours of exciting aerobatics.

## THROWS

We have provided two sets of throws. It is highly recommended that you start with the lower throws and, after a few flights, work your way up to the higher settings, if you desire. If you are using a computerized radio, always use the highest percentage possible and then mechanically adjust for the proper throw. Also, because of the high deflection and generous area of the control surfaces, it is recommended that you use exponential to soften the feel around neutral. At the lower control settings, little, if any, expo is needed. Try 15-20% at first and, for the higher settings, try about 40% for all controls. These settings are only suggestions and may be modified "to taste."

## ENGINES

This SUKHOI was designed around the .90 two-stroke and the 1.20 four-stroke engines, which will yield excellent performance. The secret is to not build too heavy. Remember, a bigger engine is not better, as it adds weight, vibration, etc. Therefore, **DO NOT** use a larger-than-recommended engine, which could result in structural failure of the aircraft. As for props, we have found that a 15-8 to 16-8 propeller and a properly sized spinner seem to work well on these engines.

## FIRST FLIGHT

Double and triple check that all is in order...extra time here is always well spent! When satisfied with controls, engine response, etc., you're ready.

When taxiing, we recommend you always maintain full up elevator, especially when flying off grass. Point the nose into the wind and gradually apply full power. As the SUKHOI accelerates, reduce the elevator setting so that, when the aircraft is ready to fly, you will have just enough up elevator to rotate and climb out at a shallow angle. Also, during the application of power, due to engine torque, the SUKHOI will veer to the left, so be prepared to hold some right rudder. In all probability, no more than 10-20% rudder input will be needed, and this should be maintained during the initial climb-out. This take-off technique is not only best for the SUKHOI, but is the proper way to take off any aircraft, particularly a tail-dragger.

Once in the air, the SUKHOI should have a fairly balanced feel. Rolls will be relatively quick, but very pre-

dictable, and pitch is very positive, but not too sensitive. Inverted flight takes a small amount of down elevator to sustain. The rudder is large and powerful, which makes "stall turns" a breeze and "knife edge flight" a pleasure. On our prototypes, we did not require any mixing to compensate roll. The nose did pitch up ever so slightly, but we did not feel it necessary to "dial" it out with the radio. Snap rolls are very quick and stop instantly. A note on snaps: you don't need high rate rudder and elevator to get the SUKHOI to snap properly. If you do that, the aircraft simply goes deeper in the stall and decelerates rapidly. Normally, this is not a problem, but if you try to snap roll on a vertical up-line, it can almost stop the aircraft. If you snap with low rate, the SUKHOI will continue to climb cleanly.

Lomcevaks are an absolute delight with the SUKHOI. It seems to do all variations well, including one in particular. From level flight and full power, pull up about 60°, roll right 90°, then snap inside left and, after about one full rotation, apply full down and opposite aileron...then hang on! Almost always, you can execute two full tumblers...and sometimes more.

Landing the SUKHOI offers no real difficulties. Because of the low wing loading, it can land very slowly, but be aware of the long landing gear and try to get most of the "fly" out before you touch down. If you happen to touch down with too much airspeed, be prepared to release some of the up elevator to prevent the aircraft from bouncing back into the air.

## REMINDER

**As good as this SUKHOI is, all aircraft have limitations and this one is no exception. Using care and common sense will help ensure the survivability of your aircraft. And, of course, always think and fly safely.**

# COLOR SCHEME

DECAL PLACEMENT AT BUILDER'S DISCRETION

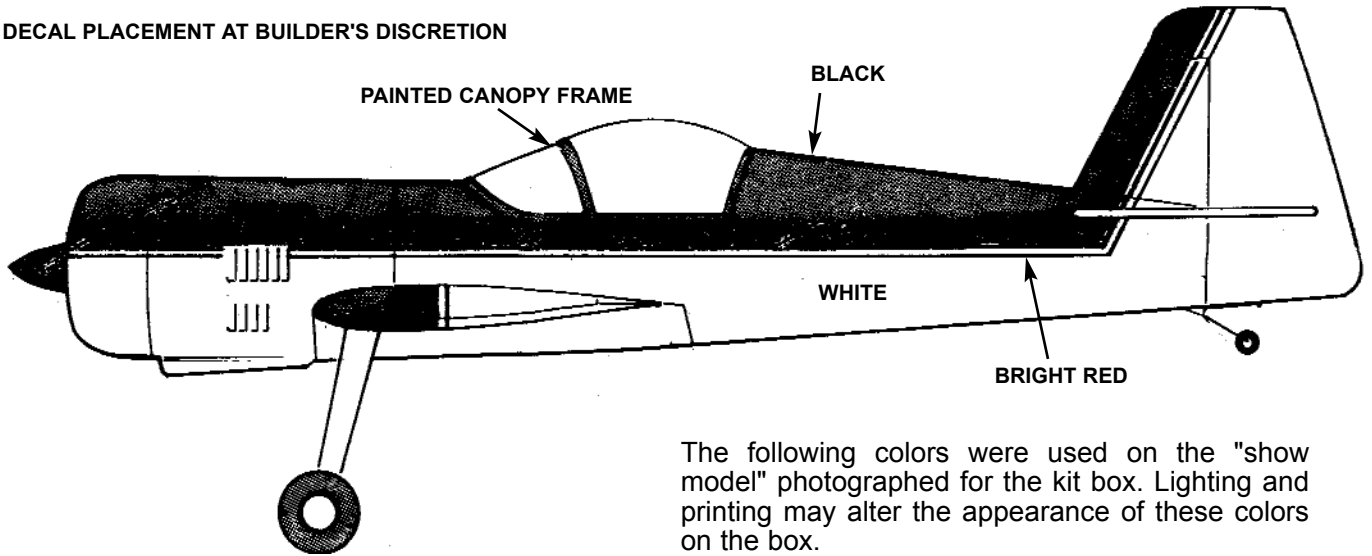

The following colors were used on the "show model" photographed for the kit box. Lighting and printing may alter the appearance of these colors on the box.

- Bright Red
- White
- Black

