

# BlitzRCWorks Navy 1100mm T-28 Trojan



## SPECIFICATIONS:

- Wingspan:1100mm (43.3in)
- Length: 930mm (35.4in)
- Flying Weight:1460g (52oz)
- Controls: 7 Channel (Aileron, Elevator, Throttle, Rudder, Flap, Gear, Airbrake)
- Motor: 3536 750Kv brushless outrunner.
- Prop: 10x6 3-Blade
- ESC: 40amp
- Battery: 4S 14.8V 25C 2200mah 4S
- Channels: 7 Channel Transmitter and Receiver

## ASSEMBLY:

1. Locate the bag marked "Aileron" and "Flap". Install aileron and flap control horns and rods for each side of the wing as shown. Ensure the servo horn is at 90 degrees to the wing when installing the rod.

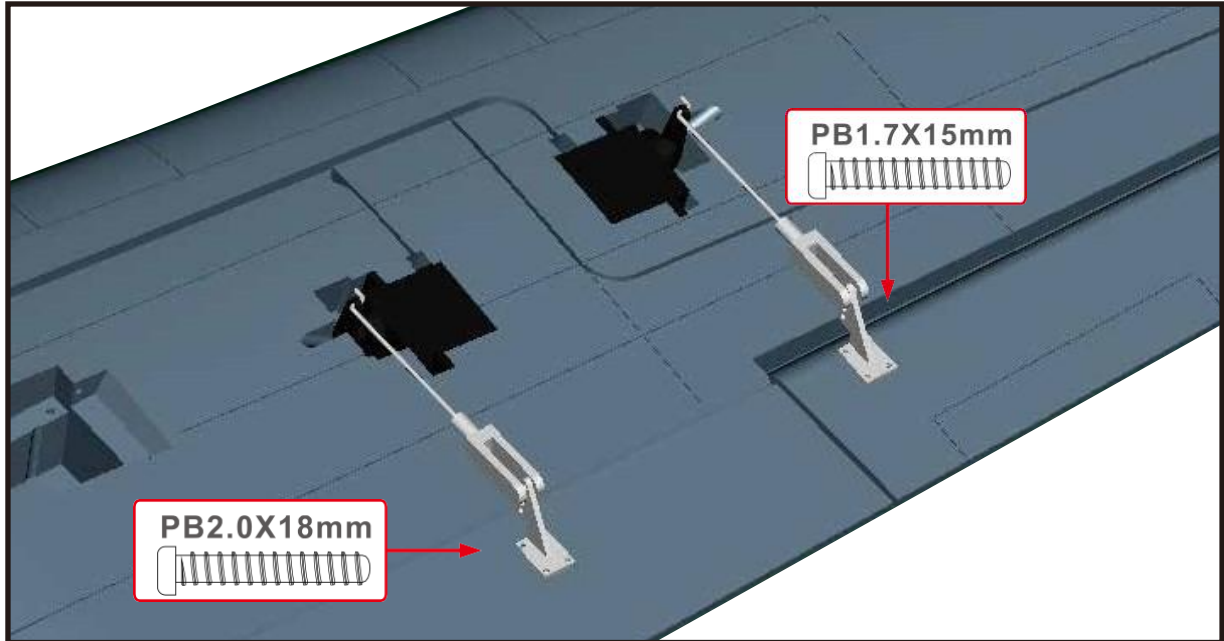

2. Install the horizontal tail to the fuselage as shown.

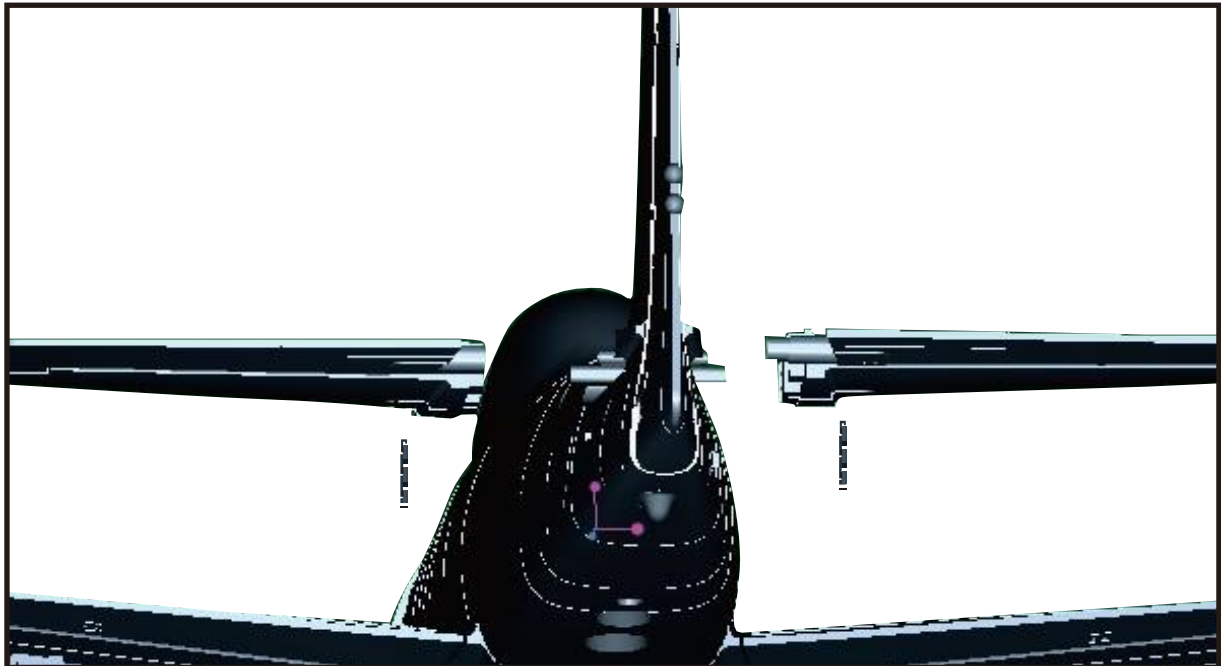

3. Locate the bag marked "Elevator" Install horizontal tail, control horns and rods with the supplied bolts as shown. Ensure tail is firmly secured and aligned.

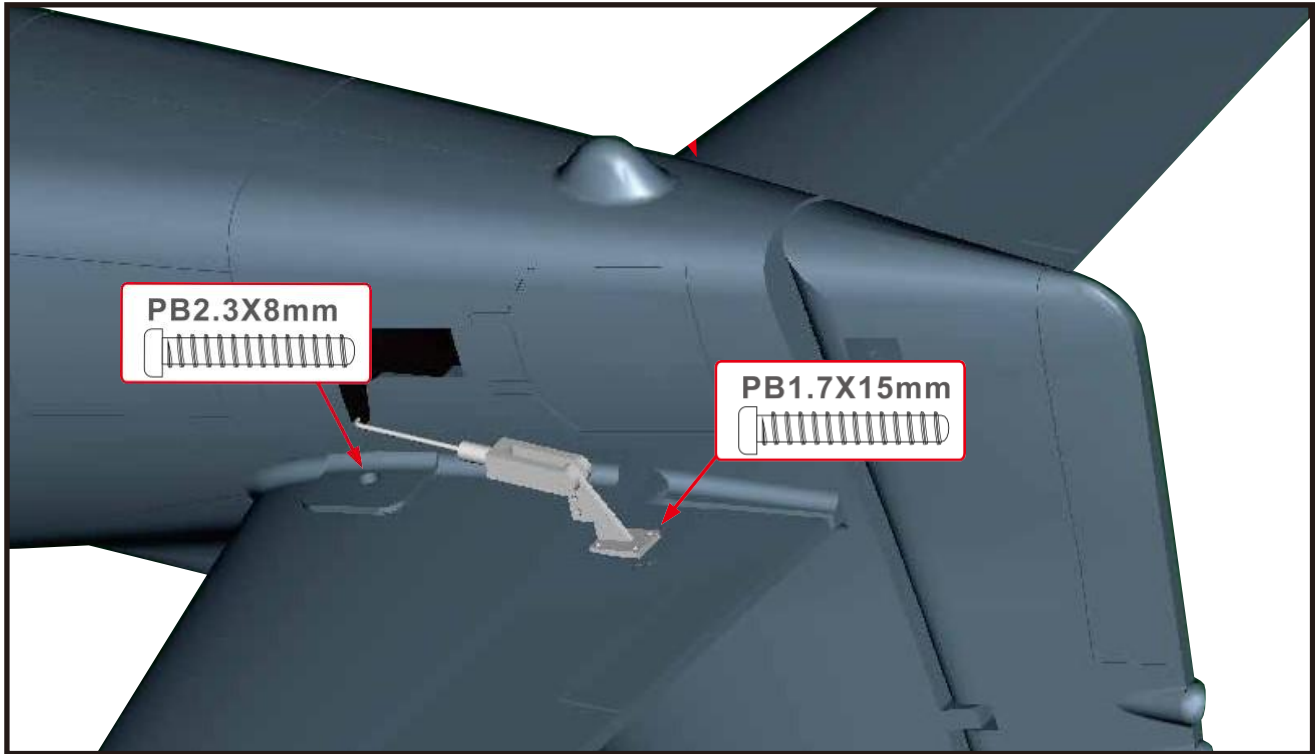

4. Locate the bag marked "Rudder" Install the control horns on the vertical tail. Connecting the pre installed control rods to the outer hold of the control horn.

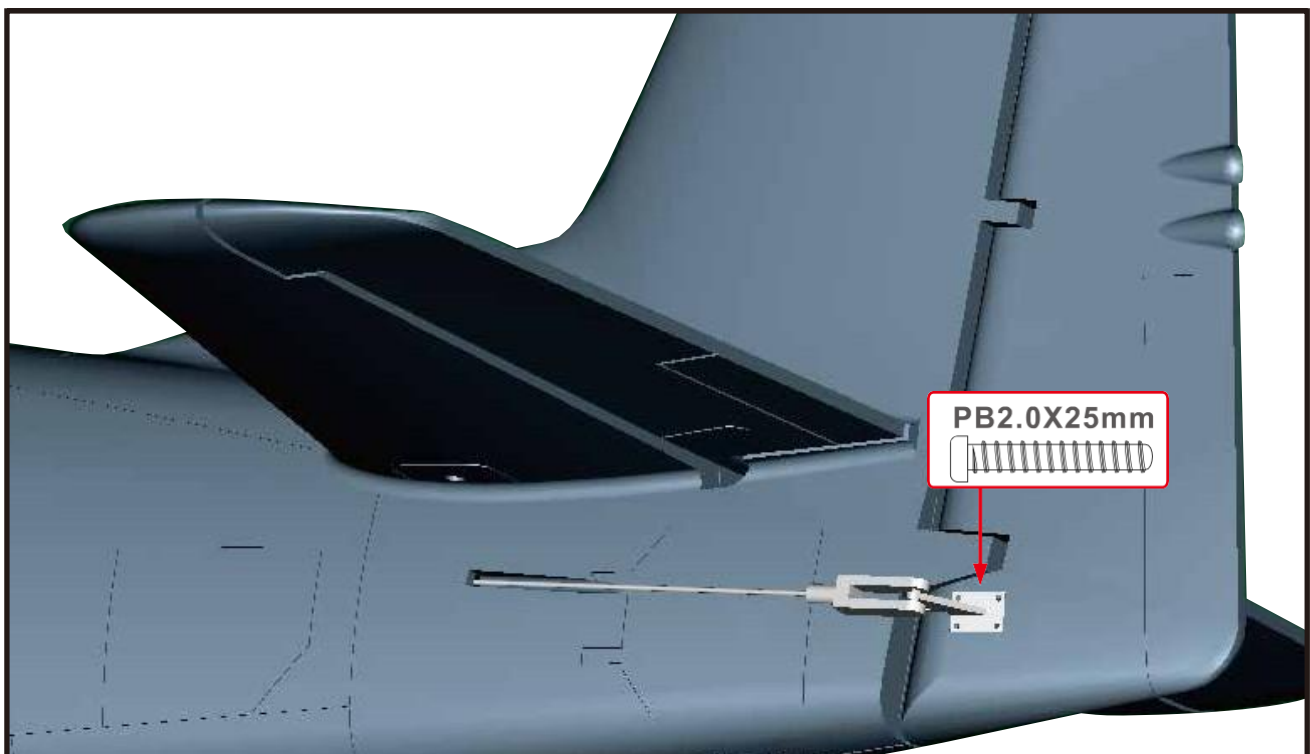



5. Mount the wing to the fuselage with the supplied bolts. Make sure to feed servo wires into passage to fuselage compartment, ensuring no wires are pinched in the wing saddle.

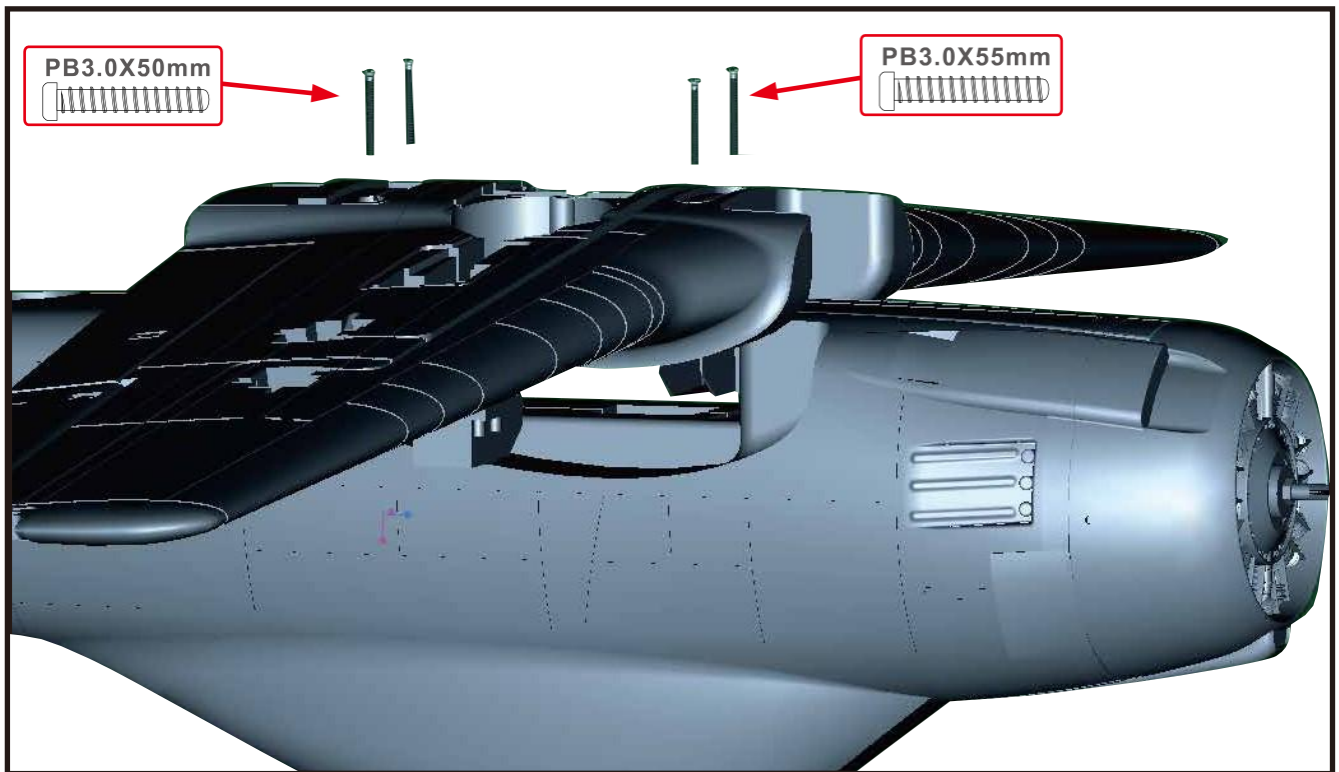

6. The final stage of assembly is to mount propeller. Slide prop onto motor shaft, engaging molded hex detail on back of propeller to hex fitting on prop shaft. Tighten prop nut to shaft firmly by hand.

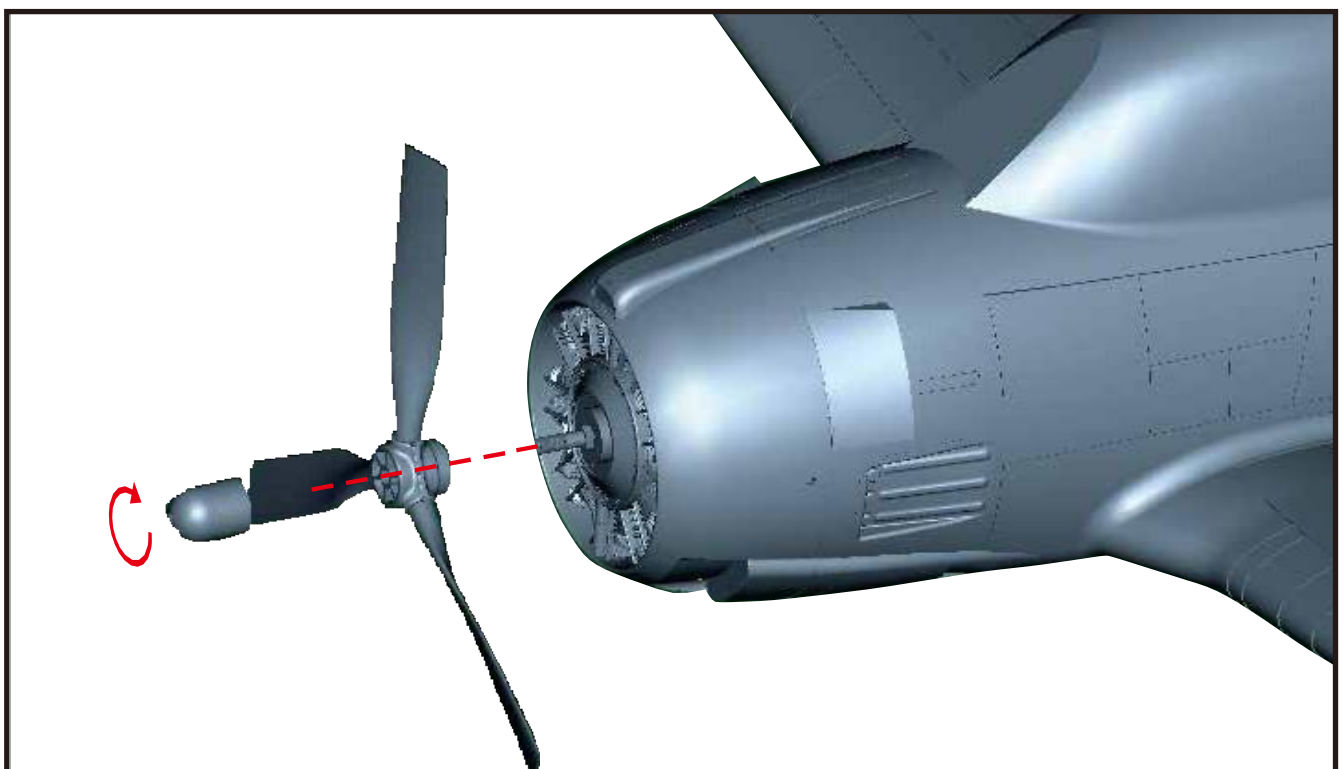

**Note: It is recommended that you balance the prop and spinner before installing for optimum performance and efficiency.**

## RADIO SET UP:

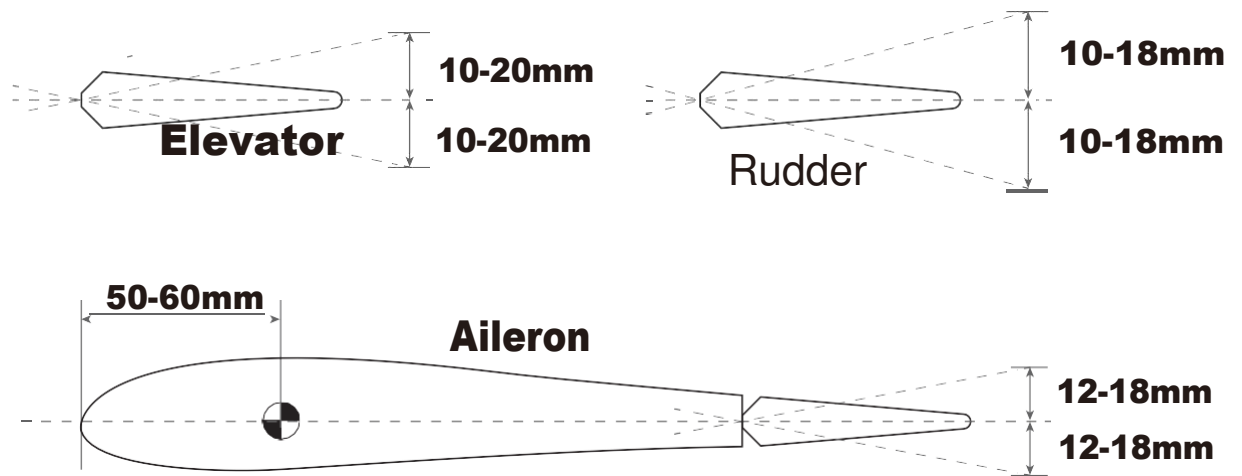

\*Elevator 'low rates' 10mm 'high rates' 20mm in either direction from neutral.

\*Rudder 'low rates' 10mm 'high rates' 18mm in either direction from neutral.

\*Aileron 'low rates' 12mm 'high rates' 18mm in either direction from neutral.

Check control surfaces for proper movement with applicable stick input. A reversed control could lead to loss of control and damage to the model.

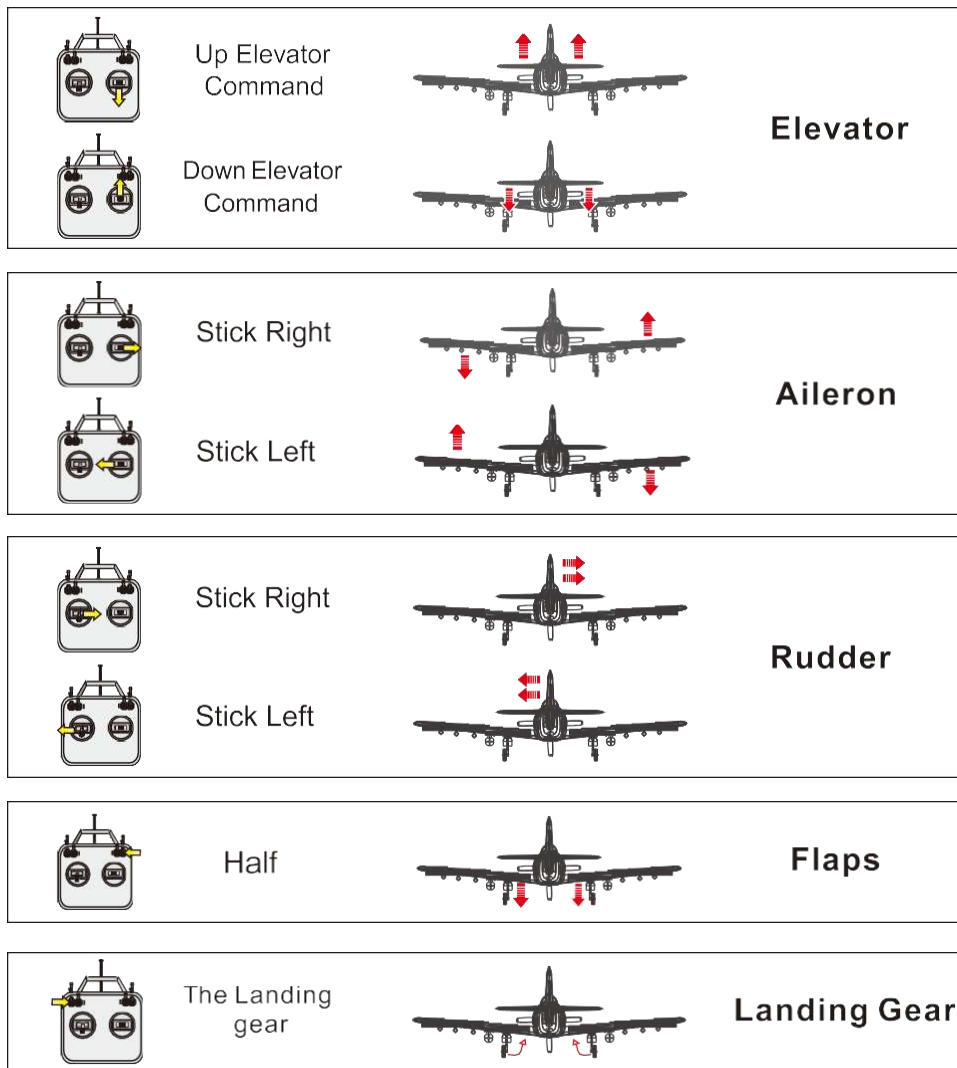

4. Linear power delivery is important to optimal flight performance. Calibrate the ESC using the instructions below when switching to a new transmitter.

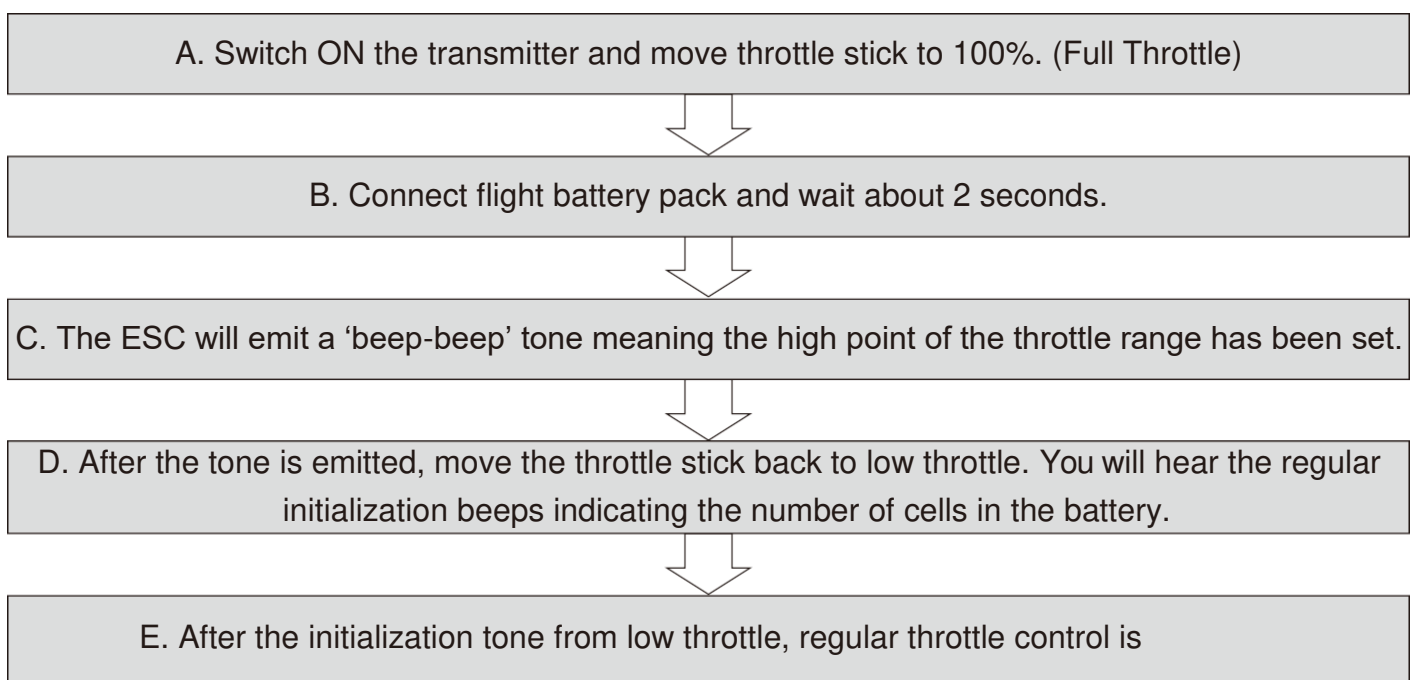

5. The center gravity (CG) for the T-28 Trojan is approximately 50-60mm from the leading edge of the wing. Using the recommended 4S 14.8V 2200mah LiPo, the correct CG can be attained quite easily due to the ample battery space. If using larger capacity batteries, you may need to shift the battery backwards more to attain the correct CG.

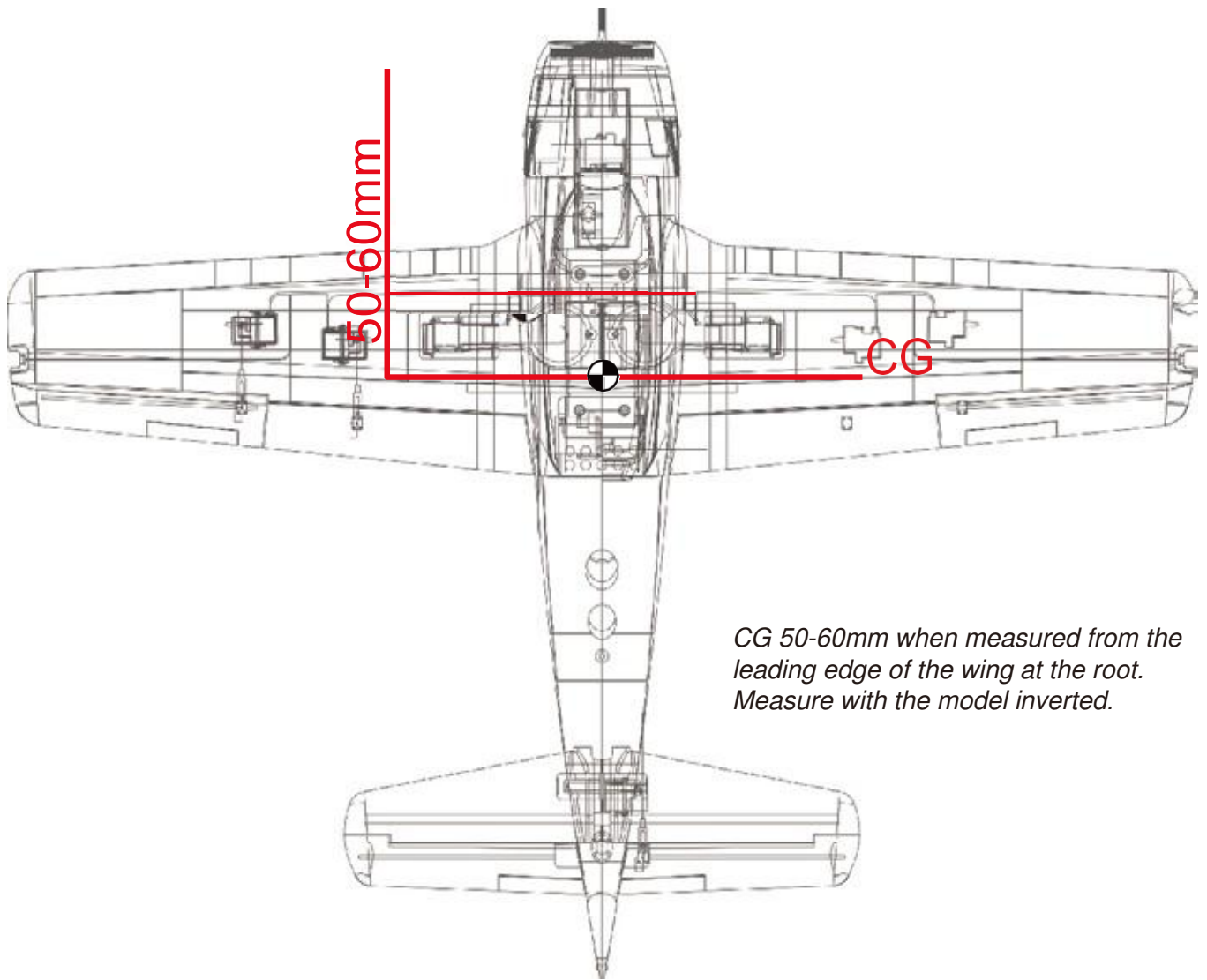

*CG 50-60mm when measured from the leading edge of the wing at the root. Measure with the model inverted.*

## TROUBLESHOOTING:

Problem	Cause	Solution
Motor does not turn	<ol style="list-style-type: none"> <li>1. Battery is not fully charged.</li> <li>2. Transmitter battery low.</li> <li>3. Motors not connected.</li> <li>4. The motor is damaged.</li> <li>5. Receiver is not bound to Tx.</li> <li>6. ESC in set-up mode.</li> </ol>	<ol style="list-style-type: none"> <li>1. Charge the batteries.</li> <li>2. Install a full charged battery.</li> <li>3. Check for connection between the ESC and motor.</li> <li>4. Replace motor.</li> <li>5. Consult Radio manual and go through bind procedure again.</li> <li>6. Hold model and move throttle to full position then back down to idle.</li> </ol>
<u>Motor turns in reverse direction</u>	<ol style="list-style-type: none"> <li>1. Motor/esc connection error</li> </ol>	<ol style="list-style-type: none"> <li>1. Swap around any 2 of the 3 ESC/motor wire connections</li> </ol>
<u>Control surfaces not moving with stick input</u>	<ol style="list-style-type: none"> <li>1. The servo lead is connected to Rx incorrectly.</li> <li>2. The servo is damaged.</li> </ol>	<ol style="list-style-type: none"> <li>1. Make sure the servo leads are connect properly.</li> <li>2. Replace servo.</li> </ol>
<u>Model does not fly straight</u>	<ol style="list-style-type: none"> <li>1. Control surfaces not centered.</li> <li>2. CoG is not in the correct position.</li> </ol>	<ol style="list-style-type: none"> <li>1. Adjust the trims on the transmitter.</li> <li>2. Re-position lipo as suggested.</li> </ol>
<u>Model does not climb well</u>	<ol style="list-style-type: none"> <li>1. The battery is not fully charged.</li> <li>2. Elevator servo is reversed.</li> <li>3. CG too far backwards.</li> </ol>	<ol style="list-style-type: none"> <li>1. Charge the battery.</li> <li>2. Changeservo direction via Tx.</li> <li>3. Move battery forwards.</li> </ol>
<u>Limited Radio Range</u>	<ol style="list-style-type: none"> <li>1. Transmitter/Receiver batteries are flat.</li> </ol>	<ol style="list-style-type: none"> <li>1. charge/replace batteries.</li> </ol>