

# Super Combo DOMINATOR T-REX 470LM

## INSTRUCTION MANUAL

## 使用說明書

RH47E01XT

# ALIGN



Contents	
1	INTRODUCTION 前言
1~2	SAFETY NOTES 安全注意事項
3	EQUIPMENT REQUIRED FOR ASSEMBLY 自備設備
3	PACKAGE ILLUSTRATION 包裝說明
4	STANDARD EQUIPMENT 標準配備
4	SAFETY CHECK BEFORE FLYING 飛行前安全檢查重要事項
5~17	ASSEMBLY SECTION 組裝說明
18	EQUIPMENT INSTALLATION 各項設備配置圖
18	BATTERY INSTALLATION ILLUSTRATION 電池安裝示意圖
18	CANOPY ASSEMBLY 機頭罩安裝
20	ELECTRIC EQUIPMENT ILLUSTRATION 電子設備建議配置圖示
20~21	MICROBEAST PLUS FLYBARLESS MANUAL 無平衡翼系統使用說明
22	SERVO SETTING AND ADJUSTMENT 伺服器設定調整
22	ADJUSTMENTS FOR GYRO AND TAIL NEUTRAL SETTING 陀螺儀與尾翼中立點設定調整
23	PITCH AND THROTTLE SETTING 主旋翼螺距與油門設定
24	RCM-BL470MX 1800KV POWER COLLOCATION REFERENCE 原裝動力數據參考表
24~27	RCE-BL50X BRUSHLESS SPEED CONTROLLER INSTRUCTION MANUAL 無刷調速器使用說明
28~30	FLIGHT ADJUSTMENT AND SETTING 飛行動作調整與設定
31	TROUBLESHOOTING 飛行中狀況排除

*Highly efficient direct belt drive control system design for prestine F3C, F3N or extreme 3D flight.*

**高性能皮帶直驅 動靜皆宜**



## MICROBEAST PLUS

BEASTX™

6-AXIS MEMS SENSOR SYSTEM FOR RC-MODELS

Thank you for purchasing of Align products. Please read the manual carefully before installing and be sure to retain the manual for future reference. Specifications, contents of parts and availability are subject to change, ALIGN RC is not responsible for inadvertent errors in this publications.



承蒙閣下選用亞拓遙控世界系列產品，謹表謝意。使用前，請務必詳閱本說明書，相信一定能夠給您帶來相當大的幫助，也請您妥善保管這本說明書，以做為日後參考。本公司將不對此印刷物之異動負責，也無法主動通知消費者任何更新或異動。本說明書內記載的材質、規格或零件包裝之內容物如有異動，請依亞拓官網公告為主。



Thank you for buying ALIGN Products. The T-REX 470LM Dominator Helicopter is designed as an easy to use, full featured Helicopter R/C model capable of all forms of rotary flight. Please read the manual carefully before assembling the model, and follow all precautions and recommendations located within the manual. Be sure to retain the manual for future reference, routine maintenance, and tuning. The T-REX 470LM Dominator is a new product developed by ALIGN. It features the best design available on the R/C helicopters market to date, providing flying stability for beginners, full aerobatic capability for advanced fliers, and unsurpassed reliability for customer support.

感謝您選購亞拓產品，為了讓您容易方便的使用 T-REX 470LM Dominator 直昇機，請您詳細的閱讀完這本說明書之後再進行組裝以及操作這台直昇機，同時請您妥善的保存這本說明書，作為日後進行調整以及維修的參考。T-REX 470LM Dominator 是由亞拓自行研發的新產品，不論您是需求飛行穩定性的初學者或是追求性能的飛行愛好者，T-REX 470LM Dominator 將是您最佳的選擇。

### WARNING LABEL LEGEND 標誌代表涵義

 FORBIDDEN 禁止	Do not attempt under any circumstances. 在任何禁止的環境下，請勿嘗試操作。
 WARNING 警告	Mishandling due to failure to follow these instructions may result in damage or injury. 因為疏忽這些操作說明，而使用錯誤可能造成財產損失或嚴重傷害。
 CAUTION 注意	Mishandling due to failure to follow these instructions may result in danger. 因為疏忽這些操作說明，而使用錯誤可能造成危險。

### IMPORTANT NOTES 重要聲明

R/C helicopters, including the T-REX 470LM Dominator are not toys. R/C helicopter utilize various high-tech products and Technologies to provide superior performance. Improper use of this product can result in serious injury or even death. Please read this manual carefully before using and make sure to be conscious of your own personal safety and the safety of others and your environment when operating all ALIGN products. Manufacturer and seller assume no liability for the operation or the use of this product. Intended for use only by adults with experience flying remote control helicopters at a legal flying field. After the sale of this product we cannot maintain any control over its operation or usage.

As the user of this product, you are solely responsible for operating it in a manner that does not endanger yourself and others or result in damage to the product or the property of others.

T-REX 470LM Dominator 遙控直昇機並非玩具，它是結合了許多高科技產品所設計出來的休閒用品，所以商品的使用不當或不熟悉都可能會造成嚴重傷害甚至死亡，使用之前請務必詳讀本說明書，勿輕忽並注意自身安全。注意！任何遙控直昇機的使用，製造商和經銷商是無法對使用者於零件使用的損耗異常或組裝不當所發生之意外負任何責任，本產品是提供給有操作過機型直昇機經驗的成人或有相當技術的人員在旁指導於當地合法遙控飛行場飛行，以確保安全無虞下操作使用，產品售出後本公司將不負任何操作和使用控制上的任何性能與安全責任。

做為本產品的使用者，您，是惟一對於您自己操作的環境及行為負全部的責任之人。

We recommend that you obtain the assistance of an experienced pilot before attempting to fly our products for the first time. A local expert is the best way to properly assemble, setup, and fly your model for the first time. T-REX 470LM Dominator requires a certain degree of skill to operate, and is a consumer item. Any damage or dissatisfaction as a result of accidents or modifications are not covered by any warranty and cannot be returned for repair or replacement. Please contact our distributors for free technical consultation and parts at discounted rates when you experience problems during operation or maintenance.

As Align Corporation Limited has no control over use, setup, final assembly, modification or misuse, no liability shall be assumed nor accepted for any resulting damage or injury. By the act of use, setup or assembly, the user accepts all resulting liability.

模型商品屬於需高操作技術且為消耗性之商品，如經拆裝使用後，會造成不等情況零件損耗，任何使用情況所造成商品不良或不滿意，將無法於保固條件內更換新品或退貨，如遇有使用操作維修問題，本公司全省分公司或代理商將提供技術指導、特價零件供應服務。對使用者的不當使用、設定、組裝、修改、或操作不良所造成的破損或傷害，本公司無法控制及負責。任何使用、設定、組裝、修改、或操作不良所造成的破損、意外或傷害，使用者應承擔全部責任。

### 2. SAFETY NOTES 安全注意事項



- Fly only in safe areas, away from other people. Do not operate R/C aircraft within the vicinity of homes or crowds of people. R/C aircraft are prone to accidents, failures, and crashes due to a variety of reasons including, lack of maintenance, pilot error, and radio interference. Pilots are responsible for their actions and damage or injury occurring during the operation or as a result of R/C aircraft models.
- Prior to every flight, carefully check rotorhead spindle shaft screws and tail blade grip screws, linkage balls and screws, ensure they are firmly secured.
- 遙控模型飛機、直昇機屬高危險性商品，飛行時務必遠離人群，人為組裝不當或機件損壞、電子控制設備不良，以及操控上的不熟悉、都有可能導致飛行失控損傷等不可預期的意外，請飛行者務必注意飛行安全，並需了解自負疏忽所造成任何意外之責任。
- 每趟飛行前須仔細檢查，主旋翼夾座橫軸螺絲、尾旋翼夾座螺絲，以及機身各部位球頭、螺絲，確實上膠鎖緊才能升空飛行。



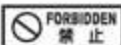

## LOCATE AN APPROPRIATE LOCATION 遠離障礙物及人群

R/C helicopters fly at high speed, thus posing a certain degree of potential danger. Choose a legal flying field consisting of flat, smooth ground without obstacles. Do not fly near buildings, high voltage cables, or trees to ensure the safety of yourself, others and your model. For the first practice, please choose a legal flying field. Do not fly your model in inclement weather, such as rain, wind, snow or darkness.

直昇機飛行時具有一定的速度，相對的也潛在著危險性，場地的選擇也相對的重要，請遵守當地法規到合法遙控飛行場地飛行。務必選擇在空曠合法專屬飛行場地，並必須注意周圍有沒有、高樓、建築物、高壓電線、樹木等等，避免操作的不當造成自己與他人財產的損壞。請勿在下雨、打雷等惡劣天候下操作，以確保本身及機體的安全。



## NOTE ON LITHIUM POLYMER BATTERIES 鋰聚電池注意事項

Lithium Polymer batteries are significantly more volatile than alkaline or Ni-Cd/Ni-MH batteries used in RC applications. All manufacturer's instructions and warnings must be followed closely. Mishandling of Li-Po batteries can result in fire. Always follow the manufacturer's instructions when disposing of Lithium Polymer batteries.

鋰聚電池跟一般在RC使用的鹼性電池、鎳鎘電池、鎳氫電池比較起來是相對危險的。請嚴格遵守鋰聚電池說明書之使用注意事項。不恰當使用鋰聚電池，可能造成火災並傷及生命財產安全，切勿大意！

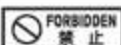
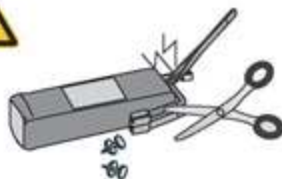

## PREVENT MOISTURE 遠離潮濕環境

R/C models are composed of many precision electrical components. It is critical to keep the model and associated equipment away from moisture and other contaminants. The introduction or exposure to water or moisture in any form can cause the model to malfunction resulting in loss of use, or a crash. Do not operate or expose to rain or moisture.

直昇機內部也是由許多精密的電子零組件組成，所以必須絕對的防止潮濕或水氣，避免在浴室或雨天時使用，防止水氣進入機身內部而導致機件及電子零件故障而引發不可預期的意外！



## PROPER OPERATION 勿不當使用本產品

Please use the replacement of parts on the manual to ensure the safety of instructors. This product is for R/C model, so do not use for other purpose.

請勿自行改造加工，任何的升級改裝或維修，請使用亞拓產品目錄中的零件，以確保結構的安全。請權處於產品限界內操作，請勿過載使用，並勿用於安全、法令外其它非法用途。



## OBTAIN THE ASSISTANCE OF AN EXPERIENCED PILOT 避免獨自操控

Before turning on your model and transmitter, check to make sure no one else is operating on the same frequency. Frequency interference can cause your model, or other models to crash. The guidance provided by an experienced pilot will be invaluable for the assembly, tuning, trimming, and actual first flight or unforeseen danger may happen. (Recommend you to practice with computer-based flight simulator.)

至飛行場飛行前，需確認是否有相同頻率的好手正進行飛行，因為開啟相同頻率的發射器將導致自己與他人立即干擾等意外危險。遙控飛機操控技巧在學習初期有著一定的難度，要盡量避免獨自操作飛行，需有經驗的人士在旁指導，才可以操控飛行，否則將可能造成不可預期的意外發生。(動線電腦模擬器及老手指導是入門必要的選擇)



## SAFE OPERATION 安全操作

Do not attempt to grab or make contact with the helicopter while the main blades are in motion and keep your eyes away from the helicopter. During take-off, landing, and flight, be sure to keep the helicopter away from all obstacles. Operators must stand at least 10 meters away from the helicopter to avoid injury caused by loose parts due to improper assembly or any unforeseen dangers. Operate this unit within your ability. Do not fly under tired condition and improper operation may cause in danger. Never take your eyes off the model or leave it unattended while it is turned on. Immediately turn off the model and transmitter when you have landed the model.

嚴禁用手抓取運行中的直昇機，並禁止將直昇機對著眼睛，當主旋翼轉動後，或起飛/試飛時，務必遠離障礙物，站立位置必需距離10公尺以上，避免因人為組裝不當造成零件脫落，而引發不可預期的財物及人員損傷。請於自己能力內及需要一定技術範圍內操作這台直昇機，過於疲勞、精神不佳或不當操作，意外發生風險將可能會提高。不可在視線範圍外進行，降落後也請馬上關掉直昇機和遙控器電源。



## ALWAYS BE AWARE OF THE ROTATING BLADES 遠離運轉中零件

During the operation of the helicopter, the main rotor and tail rotor will be spinning at a high rate of speed. The blades are capable of inflicting serious bodily injury and damage to the environment. Be conscious of your actions, and careful to keep your face, eyes, hands, and loose clothing away from the blades. Always fly the model a safe distance from yourself and others, as well as surrounding objects.

直昇機主旋翼與尾旋翼運轉時會以高轉速下進行，在高轉速下的旋翼會造成自己與他人在身體上或環境上的嚴重損傷，請勿觸摸運轉中的主旋翼與尾旋翼，並保持安全距離以避免造成危險及損壞。



## KEEP AWAY FROM HEAT 遠離熱源

R/C models are made of various forms of plastic. Plastic is very susceptible to damage or deformation due to extreme heat and cold climate. Make sure not to store the model near any source of heat such as an oven, or heater. It is best to store the model indoors, in a climate-controlled, room temperature environment.











遙控飛機多半是以PA纖維或聚乙烯、電子商品為主要材質，因此要盡量遠離熱源、日曬，以避免因高溫而變形甚至熔毀損壞的可能。



RADIO TRANSMITTER AND ELECTRONIC EQUIPMENT REQUIRED FOR ASSEMBLY 自備遙控及電子設備

  <p><b>Transmitter</b> (6-channel or more, helicopter system) 發射器 (六動以上直昇機模式遙控器)</p>	  <p>or</p>  <p><b>Receiver (6-channel or more)</b> 接收器 (六動以上)</p> <p><b>Remote Receiver</b> 衛星天線</p>
   <p><b>22.2V 6S 1,400~1,900mAh Li-Po Battery x 1</b> 22.2V 6S 1,400~1,900mAh Li-Po 電池 x 1</p>	  <p><b>RCC-300 Intelligent Battery Charger</b> RCC-300 智慧型充電器</p>

ADDITIONAL TOOLS REQUIRED FOR ASSEMBLY 自備工具

 <p><b>Swashplate Leveler</b> 十字盤調整器</p>	 <p><b>Digital Pitch Gauge</b> 電子螺距規</p>	 <p><b>Multi-function Tester</b> Voltmeter/Servo Diagnosis 多功能檢測計 電池電壓 / 伺服器檢測</p>				
 <p><b>Philips Screw Driver</b> 十字螺絲起子 φ 3.0 / φ 1.8mm</p>	 <p><b>Cutter Knife</b> 刀子</p>	 <p><b>Hexagon Screw Driver</b> 六角螺絲起子 3mm/2.5mm/2mm/1.5mm</p>	 <p><b>Needle Nose Pliers</b> 尖嘴鉗</p>	 <p><b>Oil</b> 潤滑油</p>	 <p><b>CA</b> 製膠膠</p>	 <p><b>R48</b> 黏漆膠</p>

4.PACKAGE ILLUSTRATION 包裝說明

470HC1  
470HH1  
470HB  
470HB1  
470HB3  
470HT2  
470HT3  
470HG1  
450HZ25

Canopy  
機頭罩

380 Carbon Fiber Blade X 1set  
380 碳纖維主旋翼 X 1組

470HT

Main blade

Frame set

Electronic device

**Part Quick Finder**  
零件快速購



470MX (1800KV) Brushless Motor x 1  
470MX (1800KV) 無刷馬達 x 1

RCE-BL50X Brushless ESC x 1  
RCE-BL50X 無刷定速調速器 x 1

DS455M Digital Servo x 1  
DS455M 數位伺服器 x 1

DS450M Digital Servo x 3  
DS450M 數位伺服器 x 3

Microbeast PLUS Flybarless System x 1  
無平衡翼系統 x 1



 470HC1	 470HH1	 470HB	 470HB1	 470HB3
 470HT2	 470HT3	 470HG1	 450HZ25	 M3x3 Set Screw x1 M3 止洩螺絲 x 1 Motor Pinion Helical Gear 11T x 1 馬達斜齒輪 11T x 1
 470MX (1800KV) 無刷馬達 x 1	 RCE-BL50X Brushless ESC x 1 RCE-BL50X 無刷定速調速器 x 1	 Microbeast PLUS Flybarless System x 1 無平衡翼系統 x 1	 DS450M Digital Servo x 3 DS450M 數位伺服器 x 3 DS455M Digital Servo x 1 DS455M 數位伺服器 x 1	 380 Carbon Fiber Blade X 1 380 碳纖維主翼 X 1

6. SAFETY CHECK BEFORE FLYING 飛行前安全檢查重要事項

CAREFULLY INSPECT BEFORE REAL FLIGHT 請嚴格執行飛行前檢查義務

- Before flying, please check to make sure no one else is operating on the same frequency for the safety.
- Before flight, please check if the batteries of transmitter and receiver are enough for the flight.
- Before turn on the transmitter, please check if the throttle stick is in the lowest position. IDLE switch is OFF.
- When turn off the unit, please follow the power on/off procedure. Power ON- Please turn on the transmitter first, and then turn on receiver. Power OFF- Please turn off the receiver first and then turn off the transmitter. Improper procedure may cause out of control, so please to have this correct habit.
- Before operation, check every movement is smooth and directions are correct. Carefully inspect servos for interference and broken gear.
- Check for missing or loose screws and nuts. See if there is any cracked and incomplete assembly of parts. Carefully check main rotor blades and rotor holders. Broken and premature failures of parts possibly cause resulting in a dangerous situation.
- Check all ball links to avoid excess play and replace as needed. Failure to do so will result in poor flight stability.
- Check the battery and power plug are fastened. Vibration and violent flight may cause the plug loose and result in out of control.
- 每次飛行前應先確認所使用的頻率是否會干擾他人，以確保您自身與他人的安全。
- 每次飛行前確定您發射器與接收器電池的電量是在足夠飛行的狀態。
- 開機前確認油门搖桿是否位於最低點，熄火降落開關，定速開關 (IDLE) 是否於關閉位置。
- 開機時必須遵守電源開關機的程序，開機時應先開啟發射器後，再開啟接收器電源；關機時應先關閉接收器後，再關閉發射器電源。不正確的開關程序可能會造成失控的現象，影響自身與他人的安全，請養成正確的習慣。
- 開機請先確定直昇機各個動作是否順暢，及方向是否正確，並檢查伺服器的動作是否有干涉或崩齒的情形，使用故障的伺服器將導致不可預期的危險。
- 飛行前確認沒有缺少或鬆脫的螺絲與螺帽，確認沒有組裝不完整或損毀的零件，仔細檢查主旋翼是否有損壞，特別是接近主旋翼夾座的部位。損壞或組裝不完整的零件不僅影響飛行，更會造成不可預期的危險。注意：對損耗、有裂痕零件更新及定期保養檢查的重要性。
- 檢查所有的連桿頭是否有鬆脫的情形，過鬆的連桿頭應先更新，否則將造成直昇機無法操控的危險。
- 確認電池及電源接頭是否固定牢靠，飛行中的震動或激烈的飛行，可能造成電源接頭鬆脫而造成失控的危險。

When you see the marks as below, please use glue or grease to ensure flying safety.

標有以下符號之組裝步驟，請配合上膠或上油，以確保使用之可靠度。



- CA : Apply CA Glue to fix.
- R48 : Apply Anaerobics Retainer to fix.
- T43 : Apply Thread Lock to fix.
- OIL : Add Grease.

- CA : 使用瞬間膠固定
- R48 : 使用金屬管狀固定缺氣膠固定
- T43 : 使用螺絲膠
- OIL : 添加潤滑油

When assembling ball links, make sure the "A" character faces outside.

各項塑膠膠連桿頭扣接時，A字請朝外。



Grease 潤滑油



Green 綠色



Blue 藍色



Furnished 瞬間膠



T43 Glue width : approx. 1mm  
T43 上膠寬度約 1mm

R48 metal tubular adhesive (eg. Bearings). T43 thread lock, apply a small amount on screws or metal parts and wipe surplus off. When disassembling, recommend to heat the metal joint about 15 Seconds. (NOTE : Keep plastic parts away from heat.)

R48 為強力金屬管狀 (如軸承) 接著劑，T43 為螺絲膠，膠合螺絲或金屬內外徑請務必少量使用，必要時請用手去除多餘膠量，欲拆卸時可於金屬接合部位熱烤約 15 秒。(注意！塑膠件避免接近熱源)

470HH1

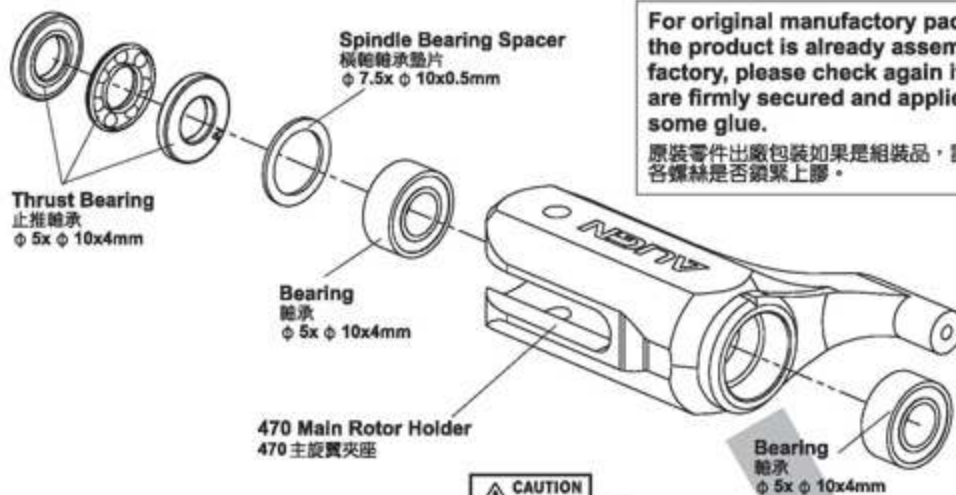

Apply a little amount of T43 thread lock when fixing a metal part.  
螺絲鎖附於金屬件請使用適量T43(螺絲膠)。

**CAUTION**  
注意

For original manufactory package, if the product is already assembled by factory, please check again if screws are firmly secured and applied with some glue.  
原裝零件出廠包裝如果是組裝品，請需再確認各螺絲是否鎖緊上膠。

**CAUTION**  
注意

Thrust bearing and washer for radial bearing are wear items, and thus should be inspected for replacement after every 20 flights. For flights with high headspeed, the inspection interval should be reduced to ensure flight safety.

止推軸承及橫軸墊圈屬於飛行消耗品，建議每20趟定期檢查及更換，高主旋翼轉速飛行時，請縮短定期檢查之週數，以確保飛行安全。

**CAUTION**  
注意



**CAUTION**  
注意



**Feathering Shaft**  
橫軸  
φ 5x60.7mm

**Apply Grease**  
塗上潤滑油

**Damper Rubber**  
橫軸墊圈  
φ 5x φ 10x4mm

**Collar**  
橫軸鉗套  
φ 5x φ 7.5x0.9mm

**CAUTION**  
注意



**Washer**  
華司  
φ 2.5x φ 7x1.2mm

470HH1

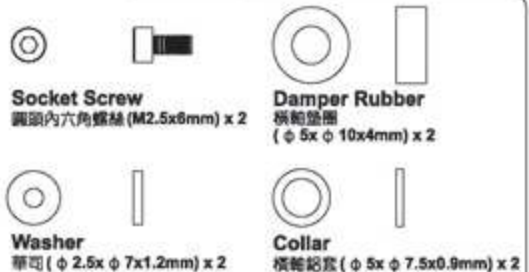

**CAUTION**  
注意

Please apply a little amount of glue when tightening the feathering shaft socket screws and make sure to tighten firmly, but not over tighten. Suggest to use torque wrench or torque lock for tightening screws with the torque value 5.0kg.cm.  
橫軸螺絲鎖附時常注意鎖附之緊度與使用適量的螺絲膠，建議搭配扭力扳手或扭力機鎖附螺絲，鎖定扭力值為5.0kg.cm。

**Socket Screw**  
圓頭內六角螺絲  
M2.5x6mm



## 470HH1



**Bearing**  
軸承 (  $\phi 1.5 \times \phi 4 \times 1.2 \text{mm}$  ) x 4



**Socket Button Head Screw**  
半圓頭內六角螺絲 (#0-80x4mm) x 4



**Linkage Ball A (M2x2.5)**  
球頭 A (M2x2.5) (  $\phi 4.75 \times 7.18 \text{mm}$  ) x 4



**Linkage Ball G (M2x2.5)**  
球頭 G (M2x2.5) (  $\phi 4.75 \times 13.52 \text{mm}$  ) x 2



**Long Linkage Ball (M2x2.5)**  
導板長球頭 (M2x2.5) (  $\phi 4.75 \times 23.52 \text{mm}$  ) x 1



**Washer**  
華司 (  $\phi 2 \times \phi 3.6 \times 0.2 \text{mm}$  ) x 2



**Socket Screw**  
圓頭內六角螺絲 (M2x14mm) x 2

Apply a little amount of T43 thread lock when fixing a metal part.  
螺絲鎖附於金屬件請使用適量T43(螺絲膠)。

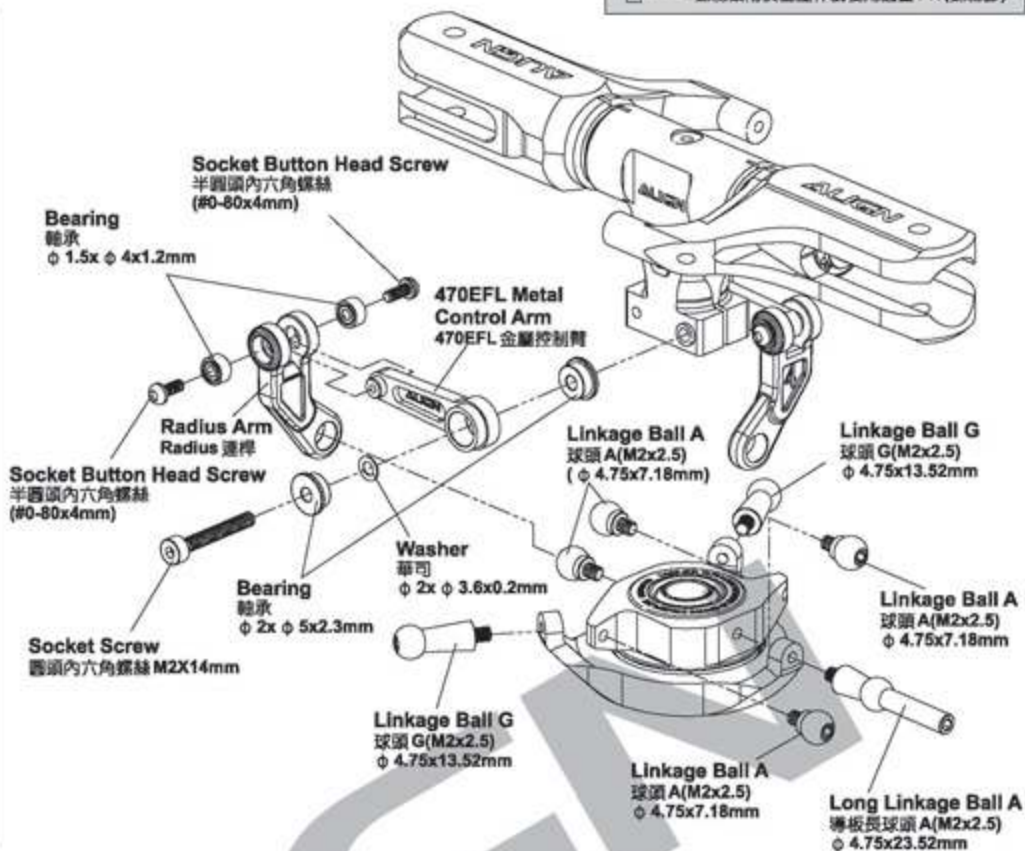

## 470HH1



**470 Linkage Rod(A)**  
470 連桿 A ( M2x16mm ) x 2



**600 Ball Link**  
600 連桿頭 x 4



**470EFL Linkage Ball A (M2x2.5)**  
470EFL 球頭 A (M2x2.5) (  $\phi 2 \times 9.35 \text{mm}$  ) x 2



**M2.5 Nut**  
M2.5 防鬆螺帽 x 1



**Socket Collar Screw**  
圓頭內六角軸套螺絲 (M2.5x12mm) x 1

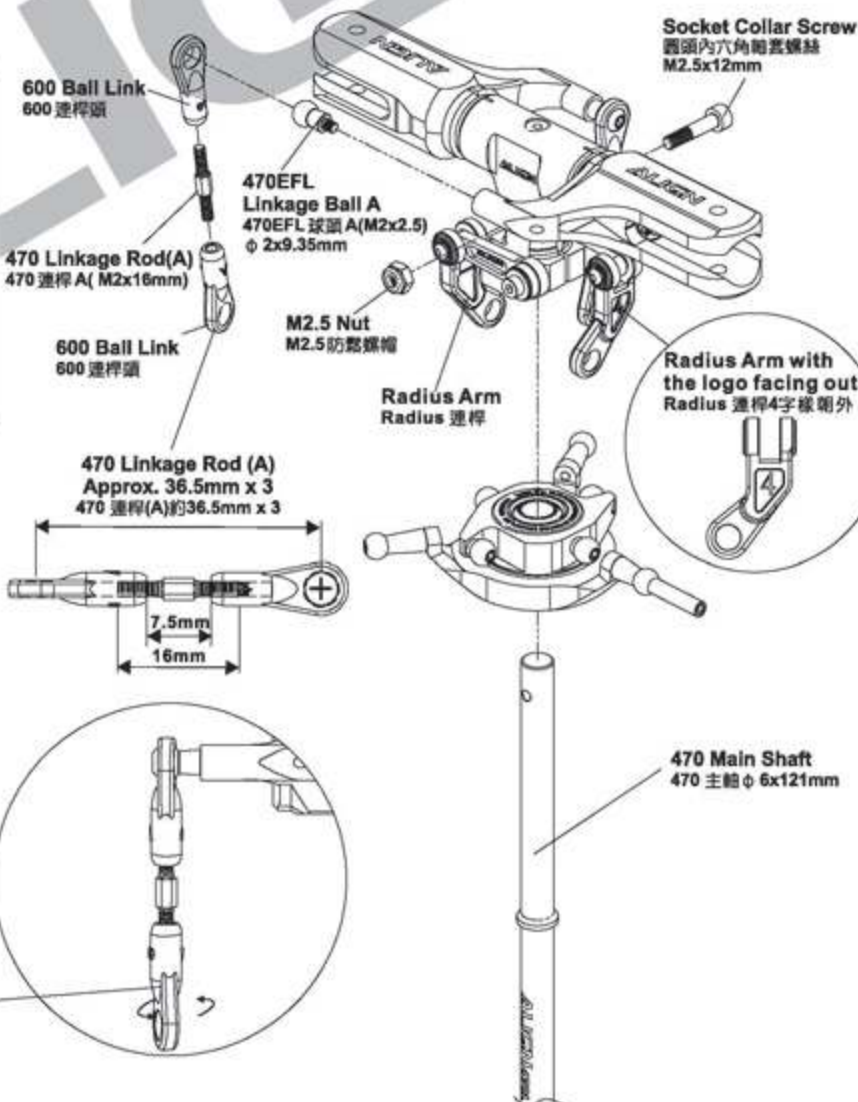

### CAUTION 注意

For original manufactory package, if the product is already assembled by factory, please check again if screws are firmly secured and applied with some glue.

原裝零件出廠包裝如果是組裝品，請需再確認各螺絲是否鎖緊上膠。

You may adjust the length of ball link when tracking is off while flight.

若飛行中有雙變情形，可適當調整連桿頭長短改善。

## 470HB2



**Bearing**  
軸承 (  $\phi 6x \phi 12x4mm$  ) x 2



**Socket Screw**  
圓頭內六角螺絲 (M2.5x5mm) x 10



**Socket Screw**  
圓頭內六角螺絲 (M2.5x6mm) x 4



**Gyro Mount (Position#2)**  
陀螺儀固定座 (位置2)

Apply a little amount of T43 thread lock when fixing a metal part.  
螺絲鎖附於金屬件請使用適量T43(螺絲膠)。



**CAUTION**  
注意  
For original manufactory package, if the product is already assembled by factory, please check again if screws are firmly secured and applied with some glue.

原裝零件出廠包裝如果是組裝品，請需再確認各螺絲是否鎖緊上膠。

**Bearing**  
軸承  
 $\phi 6x \phi 12x4mm$

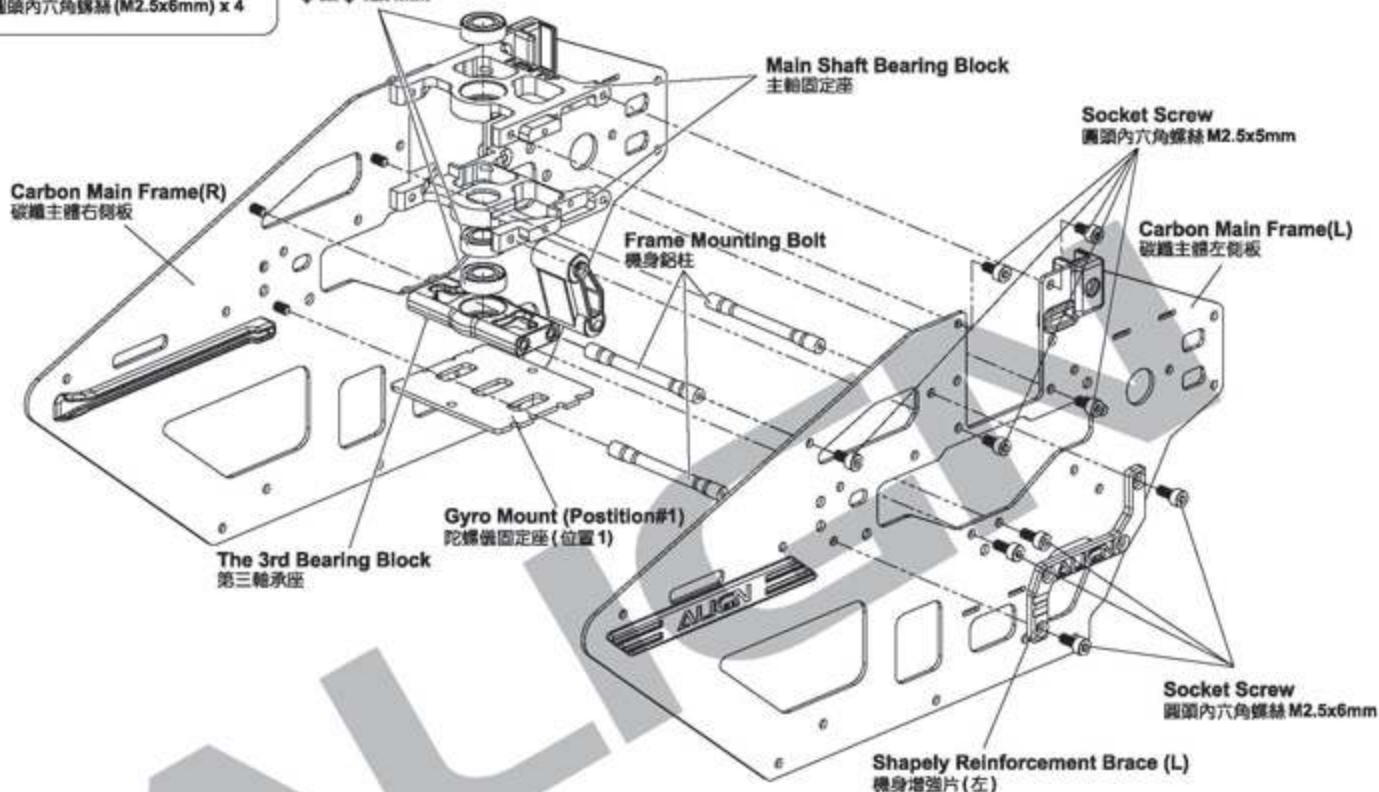

**Carbon Main Frame(R)**  
碳纖維主體右側板

**Main Shaft Bearing Block**  
主軸固定座

**Socket Screw**  
圓頭內六角螺絲 M2.5x5mm

**Frame Mounting Bolt**  
機身固定柱

**Carbon Main Frame(L)**  
碳纖維主體左側板

**Gyro Mount (Position#1)**  
陀螺儀固定座 (位置1)

**The 3rd Bearing Block**  
第三軸承座

**Socket Screw**  
圓頭內六角螺絲 M2.5x6mm

**Shapely Reinforcement Brace (L)**  
機身增強片 (左)

## 470HB2



**Washer**  
華司 (  $\phi 2.6x \phi 5.8x0.6mm$  ) x 3



**Socket Screw**  
圓頭內六角螺絲 (M2.5x5mm) x 1



**Socket Screw**  
圓頭內六角螺絲 (M2.5x8mm) x 2

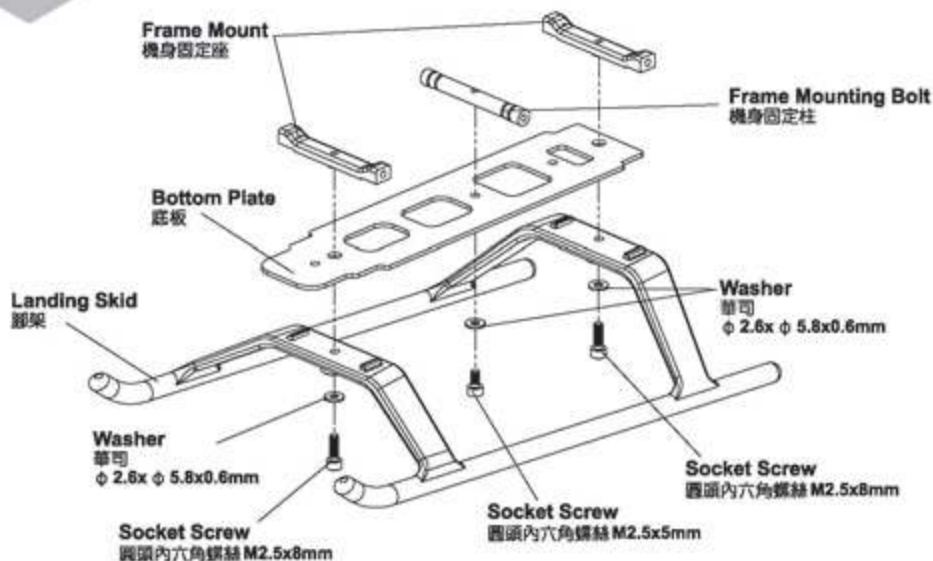

**Frame Mount**  
機身固定座

**Frame Mounting Bolt**  
機身固定柱

**Bottom Plate**  
底板

**Landing Skid**  
腳架

**Washer**  
華司  
 $\phi 2.6x \phi 5.8x0.6mm$

**Washer**  
華司  
 $\phi 2.6x \phi 5.8x0.6mm$

**Socket Screw**  
圓頭內六角螺絲 M2.5x8mm

**Socket Screw**  
圓頭內六角螺絲 M2.5x8mm

**Socket Screw**  
圓頭內六角螺絲 M2.5x5mm

## PROGRESSIVE LIGHTWEIGHT LANDING SKID

前衛新型前傾輕量化設計的腳架

Landing skid is tilted 5 degree forward which improves crashworthiness.

新型腳架輕耐撞擊，為前傾5度前衛設計。







### Main frame assembly key point :

First do not fully tighten the screws of main frames and put two bearings through the main shaft to check if the movements are smooth. The bottom bracket must be firmly touched the level table top(glass surface) ; please keep the smooth movements on main shaft and level bottom bracket, then slowly tighten the screws. This assembly can help for the power and flight performance.

### 機身側板組立重點：

側板螺絲先不完全鎖緊，放入主軸貫穿二顆軸承確認上下移動必需滑順，主體底板必須與水平桌面(玻璃平面)踏實緊貼；請保持主軸滑順與底板平行桌面後慢慢鎖緊螺絲。正確側板的組裝對動力與飛行性能有顯著幫助。

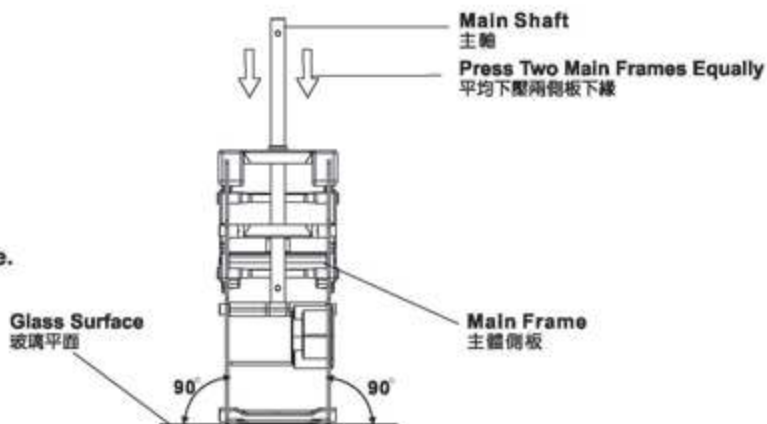

Apply a little amount of T43 thread lock when fixing a metal part.  
鎖緊螺絲於金屬件請使用適量T43(鎖絲膠)。

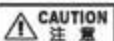

For original manufactory package, if the product is already assembled by factory, please check again if screws are firmly secured and applied with some glue.

原裝零件出廠包裝如果是組裝品，請需再確認各螺絲是否鎖緊上膠。

Recommend sanding the marked position with a waterproof abrasive paper (#800-1000) as below illustration to avoid the wires of electric parts to be cut.

建議於下圖色塊標示處，可使用#800~1000水砂紙打磨，可防止電子設備電線被割破。

Waterproof Abrasive Paper  
水砂紙



## 470HB2



Socket Screw  
圓頭內六角螺絲 (M2.5x5mm) x 4



Socket Screw  
圓頭內六角螺絲 (M2.5x6mm) x 4

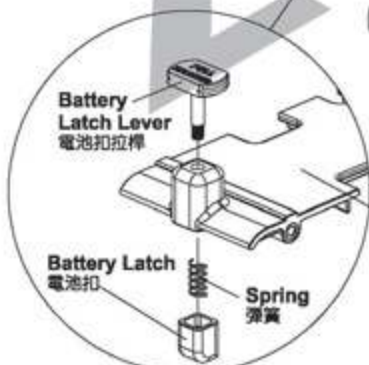

Battery Release Latch  
Installation Illustration  
電池扣安裝示意圖

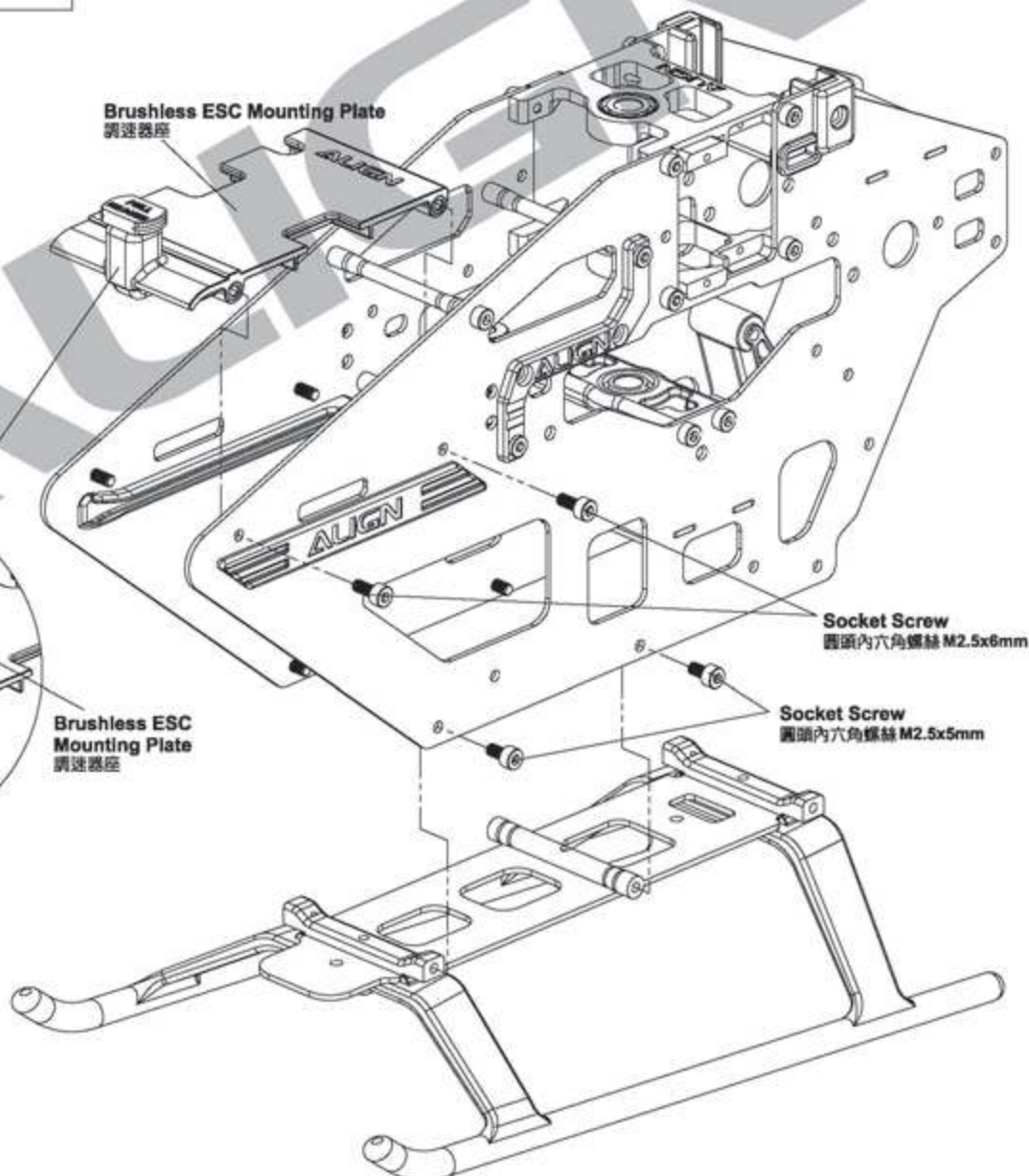

## 470HZ2

   
**M2 Nut**  
 M2 螺帽 x 3

   
**Socket Button Head Screw**  
 半圓頭內六角螺絲 (M2x4mm) x 3

   
**Linkage Ball A (M2x3.5)**  
 球頭 A (M2x3.5) (φ 4.75x8.18mm) x 1

   
**Linkage Ball B (M2x3)**  
 球頭 B (M2x3) (φ 4.75x10.84mm) x 3

## 470HB2

   
**Socket Button Head Screw**  
 半圓頭內六角螺絲 (M2x6mm) x 6

 Apply a little amount of T43 thread lock when fixing a metal part.  
 螺絲鎖附於金屬件請使用適量T43(螺絲膠)。

 **CAUTION**  
 注意

For original manufactory package, if the product is already assembled by factory, please check again if screws are firmly secured and applied with some glue.

原裝零件出廠包裝如果是組裝品，請需再確認各螺絲是否鎖緊上膠。

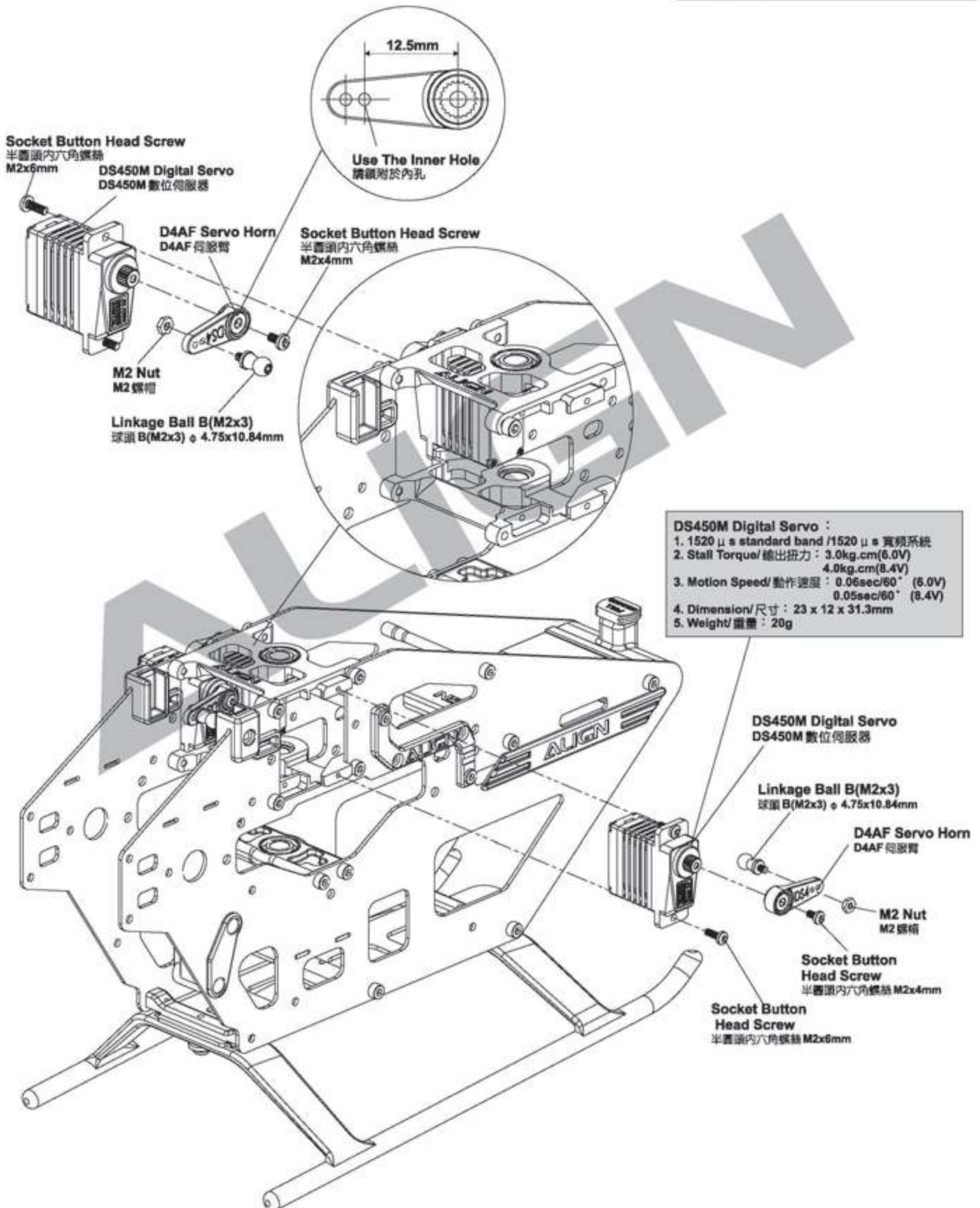

- DS450M Digital Servo :**
1. 1520 μs standard band / 1520 μs 實頻系統
  2. Stall Torque/ 輸出扭力: 3.0kg.cm(6.0V)  
4.0kg.cm(8.4V)
  3. Motion Speed/ 動作速度: 0.06sec/60° (6.0V)  
0.05sec/60° (8.4V)
  4. Dimension/ 尺寸: 23 x 12 x 31.3mm
  5. Weight/ 重量: 20g

**DS450M Digital Servo**  
 DS450M 數位伺服器

**Linkage Ball B (M2x3)**  
 球頭 B (M2x3) φ 4.75x10.84mm

**D4AF Servo Horn**  
 D4AF 伺服臂

**M2 Nut**  
 M2 螺帽

**Socket Button Head Screw**  
 半圓頭內六角螺絲 M2x4mm

**Socket Button Head Screw**  
 半圓頭內六角螺絲 M2x6mm



# 470HT1



Already assembled by factory,  
please note to check again.  
已組裝完成，請務必自行再確認。



Apply a little amount of T43 thread  
lock when fixing a metal part.  
螺絲鎖附於金屬件請使用適量T43(螺絲膠)。

   
**Socket Screw**  
圓頭內六角螺絲 (M2x5mm) x 2

   
**Socket Button Head Screw**  
半圓頭內六角螺絲 (M2x8mm) x 2

   
**Bearing**  
軸承 (φ 2x φ 4.5x2mm) x 2

   
**Washer**  
華司 (φ 2x φ 3.6x0.5mm) x 2

   
**Belt Pulley**  
皮帶輪 (φ 4.5x φ 8x6.2mm) x 2

   
**Tension Spring**  
皮帶輪彈簧 (φ 4x φ 5.2x11mm) x 2

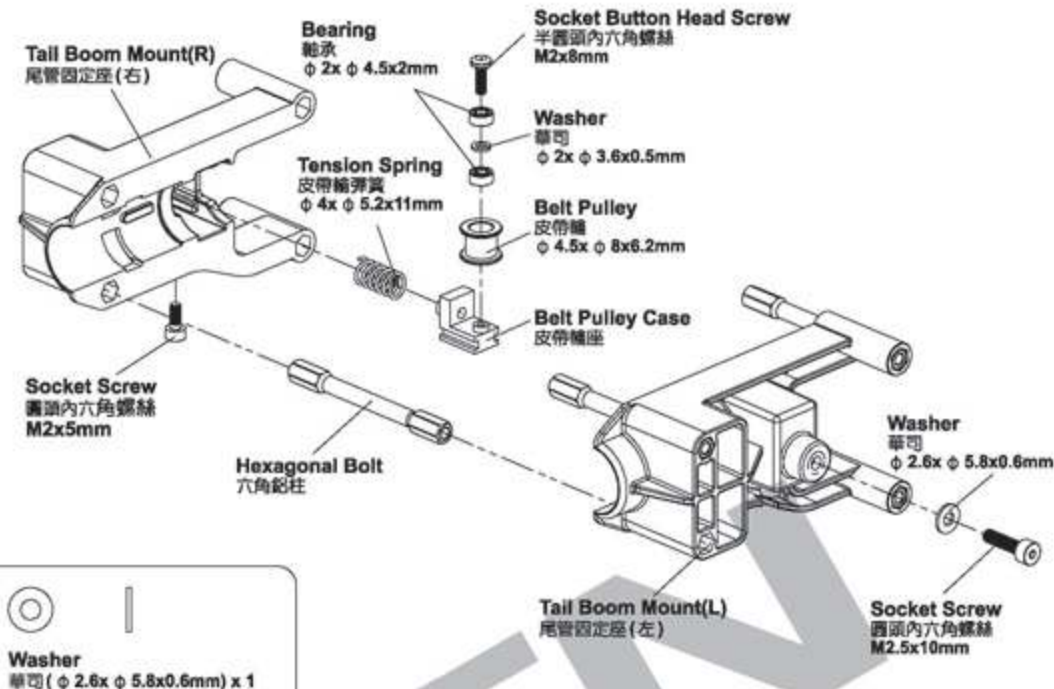

   
**Washer**  
華司 (φ 2.6x φ 5.8x0.6mm) x 1

# 470HT1

       
**Socket Screw**  
圓頭內六角螺絲 (M2.5x6mm) x 8

**Socket Screw**  
圓頭內六角螺絲 (M2.5x10mm) x 2

**Washer**  
華司 (φ 2.6x φ 5.8x0.6mm) x 1

**CAUTION**  
注意

For original manufactory package, if  
the product is already assembled by  
factory, please check again if screws  
are firmly secured and applied with  
some glue.

原廠零件出廠包裝如果是組裝品，請需再確認  
各螺絲是否鎖緊上膠。

**CAUTION**  
注意

Gently pull belt through the tail boom  
in the direction from the tail to nose  
of the helicopter.

請將皮帶由尾管固定座後方穿入機身內。

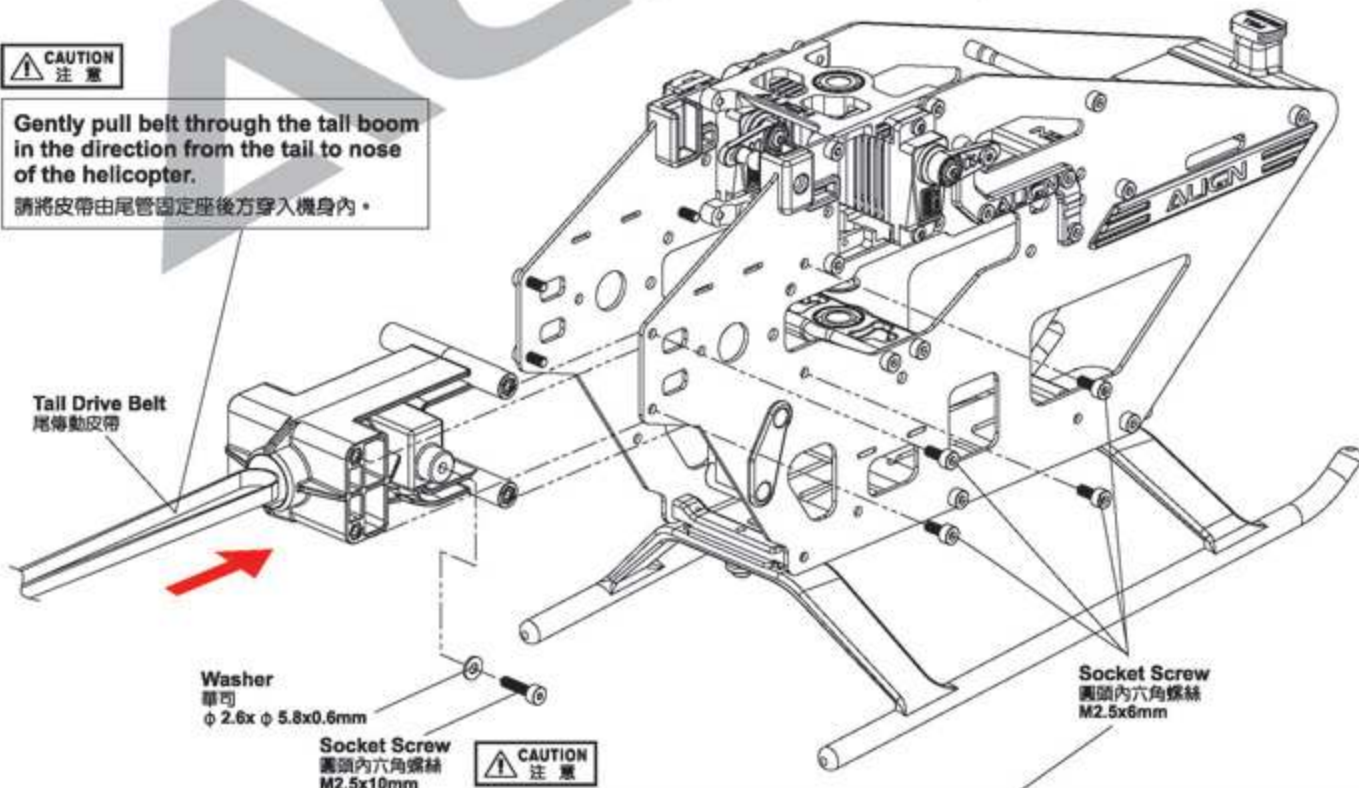

**CAUTION**  
注意

Insert the screws; however, do not tighten! Insert the tail boom and belt, place the  
belt over the pulley. Tighten all screws and confirm belt tension is correct.

先以螺絲虛鎖定位，待尾管及皮帶組裝完成後再確實鎖緊。

## 470HZ2

Apply a little amount of T43 thread lock when fixing a metal part.  
螺絲鎖附於金屬件請使用適量T43(螺絲膠)。



**CAUTION 注意**  
For original manufactory package, if the product is already assembled by factory, please check again if screws are firmly secured and applied with some glue.  
原裝零件出廠包裝如果是組裝品，請再確認各螺絲是否鎖緊上膠。



M2 Nut  
M2 螺帽 x 1



Linkage Ball A(M2x3.5)  
球頭A(M2x3.5)( $\phi$  4.75x8.18mm) x 1



Socket Button Head Screw  
半圓頭內六角螺絲 (M2x4mm) x 1



Socket Button Head Self Tapping Screw  
半圓頭內六角自攻螺絲 (T2x8mm) x 2

Anti Rotation Bracket  
十字盤導板

## 470HB2



Canopy Mounting Bolt  
機頭罩固定柱 (2.5x28.5mm) x 2



Socket Button Head Self Tapping Screw  
半圓頭內六角自攻螺絲 (T2.6x8mm) x 2

The Innermost Hole  
最內孔



Socket Button Head Screw  
半圓頭內六角螺絲 M2x4mm

Linkage Ball A(M2x3.5)  
球頭A(M2x3.5)  
 $\phi$  4.75x8.18mm

M2 Nut  
M2 螺帽

D4BF Servo Horn  
D4BF 伺服臂

DS455M Digital Servo  
DS455M 數位伺服器

DS455M Digital Servo:

- 1.1520  $\mu$ s standard band /1520  $\mu$ s 寬頻系統
- 2.Stall torque/輸出扭力:2.2kg.cm(6.0V)  
2.9kg.cm(8.4V)
- 3.Motion speed/動作速度:0.05sec/60° (6.0V)  
0.04sec/60° (8.4V)
- 4.Dimension/尺寸:23 x 12 x 31.3mm
- 5.Weight/重量:20g

Socket Button Head Self Tapping Screw  
半圓頭內六角自攻螺絲 T2x8mm

Tail Servo Mount  
尾伺服器固定座

## 470HB2



Socket Button Head Self Tapping Screw  
半圓頭內六角自攻螺絲 (T2.6x6mm) x 2

## 470HB3

Cross Screw  
皿頭十字螺絲 (M2X4mm) x 4

Cross Screw  
皿頭十字螺絲 (M2X6mm) x 3

Socket Screw  
圓頭內六角螺絲 (M2x4mm) x 3

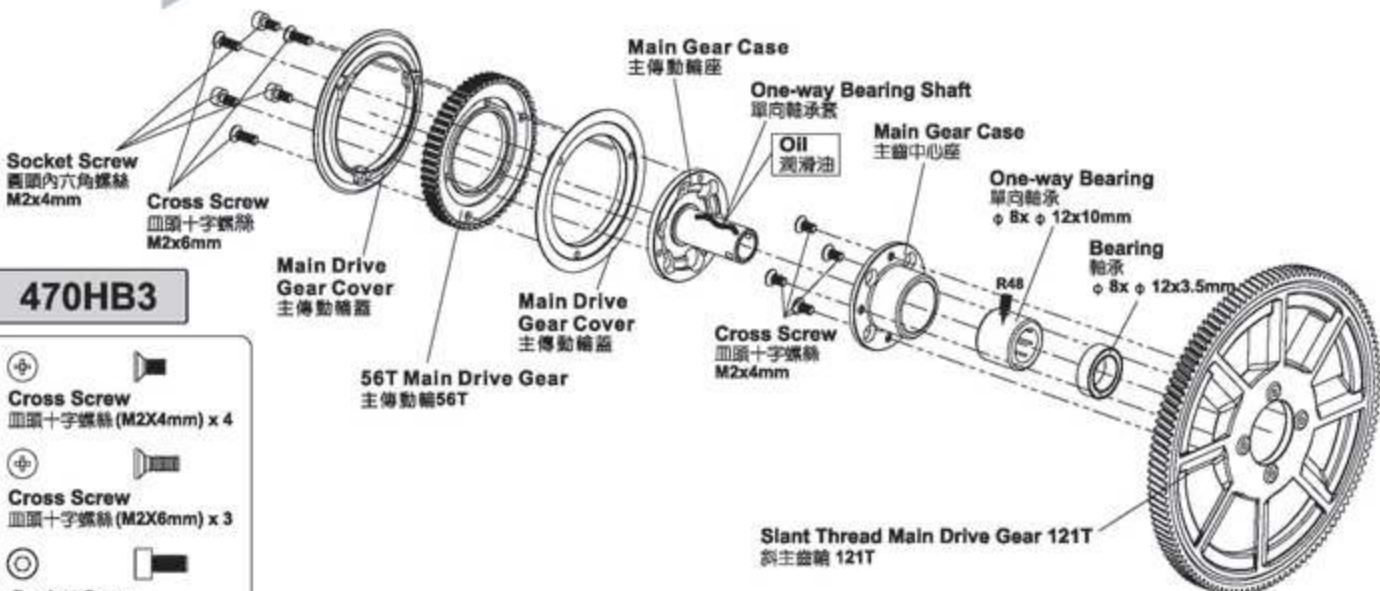



## 470HB2



## 470HZ1



## 470HZ3

Please add a main shaft spacer if necessary.  
依需求加裝主軸墊片



Apply a little amount of T43 thread lock when fixing a metal part.  
螺絲鎖附於金屬件請使用適量T43(螺絲膠)。



For original factory package, if the product is already assembled by factory, please check again if screws are firmly secured and applied with some glue.

原裝零件出廠包裝如果是組裝品，請再確認各螺絲是否鎖緊上膠。

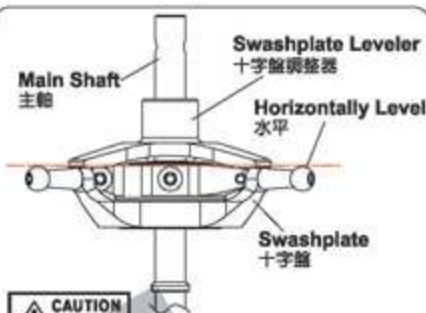

While using Flybarless system, please use the swashplate leveler to calibrate swashplate. Adjust the length of servo linkage rod to make sure the swashplate is leveled before start setting up to ensure the gyro provides the best performance.

使用無平衡系統，請務必使用十字盤調整器校正十字盤，調整伺服連桿長度，確保十字盤達到水平狀態，再進行基本機體設定，這樣才能確保飛行性能達到最佳效果。

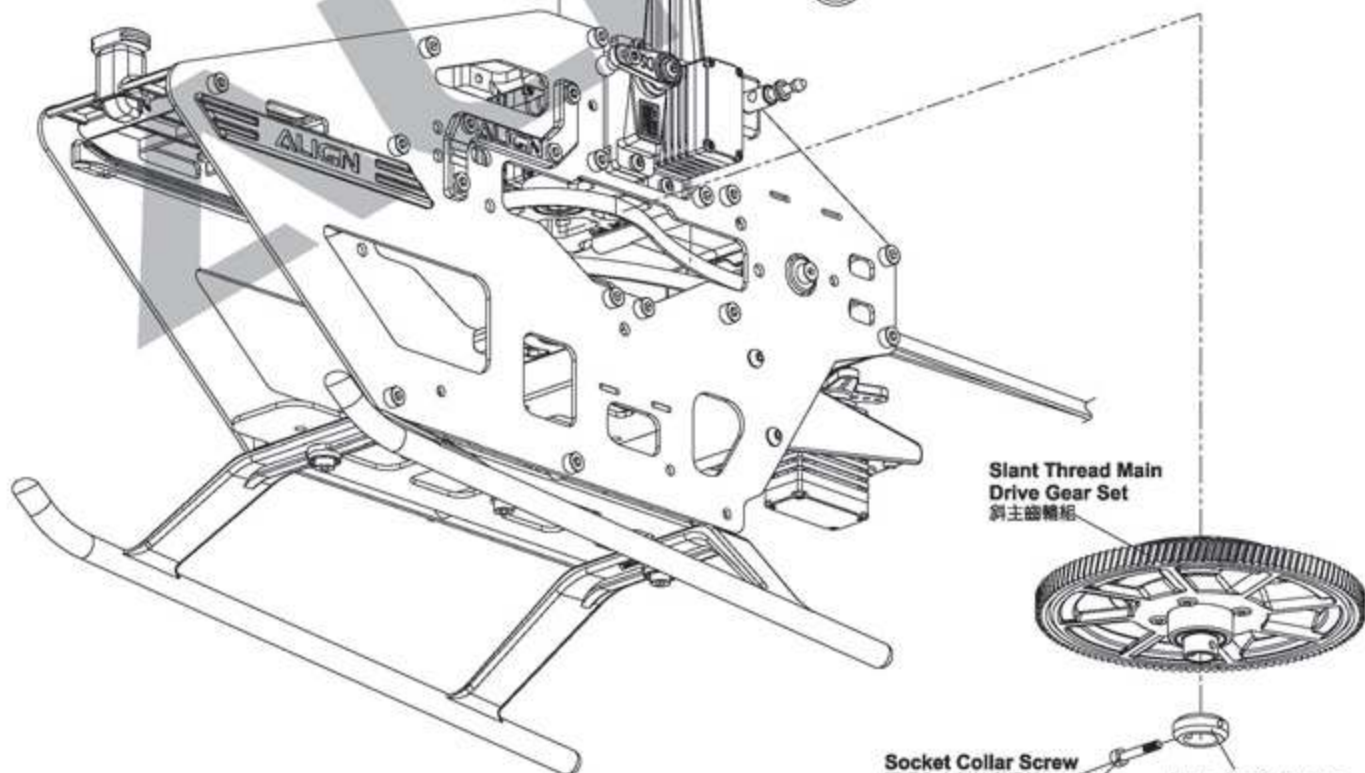
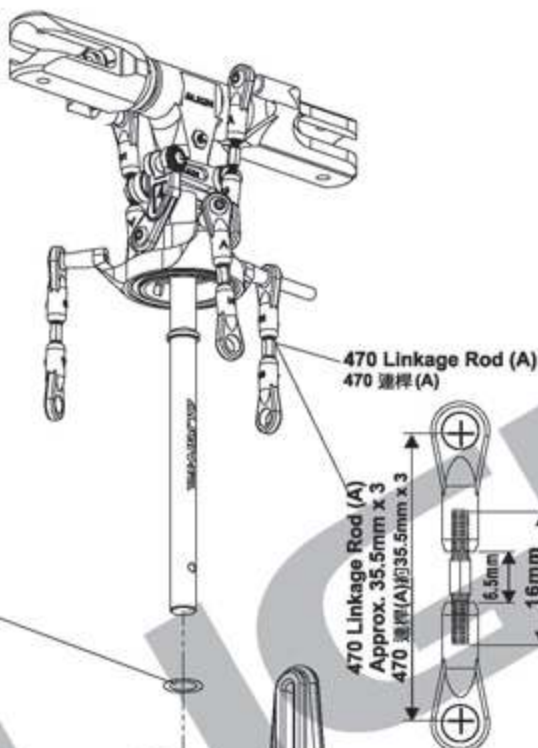

Install the main shaft into the main drive gear after the belt has been installed, then align main shaft with the main shaft mounting sleeve, insert screw and tighten. DO NOT over tighten as this may cause damage of main shaft mounting sleeve.

請將組裝完成之主軸穿入已裝好皮帶的斜主齒輪組，穿入後對準主軸固定套上的孔位鎖附。並以適當扭力鎖附即可，過度鎖緊易造成主軸固定套滑牙。

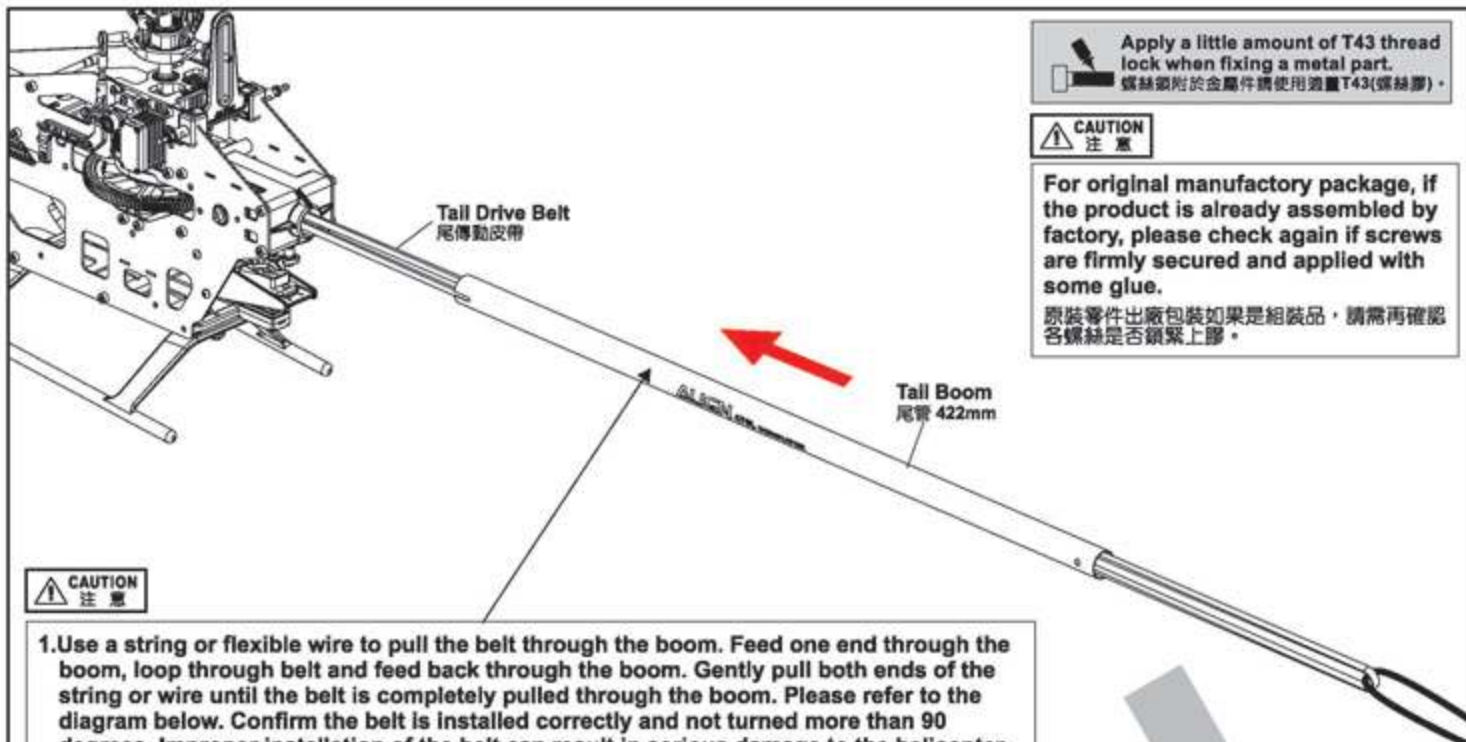

Apply a little amount of T43 thread lock when fixing a metal part.  
 螺絲鎖附於金屬件請使用適量T43(螺絲膠)。

**CAUTION**  
 注意

For original manufactory package, if the product is already assembled by factory, please check again if screws are firmly secured and applied with some glue.  
 原裝零件出廠包裝如果是組裝品，請再確認各螺絲是否鎖緊上膠。

**CAUTION**  
 注意

1. Use a string or flexible wire to pull the belt through the boom. Feed one end through the boom, loop through belt and feed back through the boom. Gently pull both ends of the string or wire until the belt is completely pulled through the boom. Please refer to the diagram below. Confirm the belt is installed correctly and not turned more than 90 degrees. Improper installation of the belt can result in serious damage to the helicopter or people.

2. When assembling the tail boom ensure the boom is properly installed in the tail boom mount and check to make sure belt is in the correct position.

1. 建議使用鐵絲或繩子拉緊皮帶的另一端將皮帶穿過尾管，皮帶組裝方向請依下方尾傳動皮帶裝配圖示安裝，確認皮帶組裝方向正確，否則將發生不可預期的危險。

2. 尾管組裝時必須確實頂住尾管固定座，以確保皮帶調整位置正確。

### DRIVE BELT ILLUSTRATION

尾傳動皮帶裝配圖示

Front  
前



Tail belt must have a 90 degree counterclockwise turn from the front tail assembly to the rear tail assembly.  
 皮帶尾部組裝應逆時針90度旋轉。

Back  
後

**WARNING**  
 警告

DO NOT turn the belt greater than 90 degrees or the tail rotor system will fail.  
 皮帶組裝時須保持並行，嚴禁重疊交錯。



### 470HT2

- Bearing  
軸承 (φ 3x φ 8x3mm) x 2
- Socket Button Head Screw  
半圓頭內六角螺絲 (M2x5mm) x 4
- Socket Button Head Screw  
半圓頭內六角螺絲 (M2x12mm) x 1

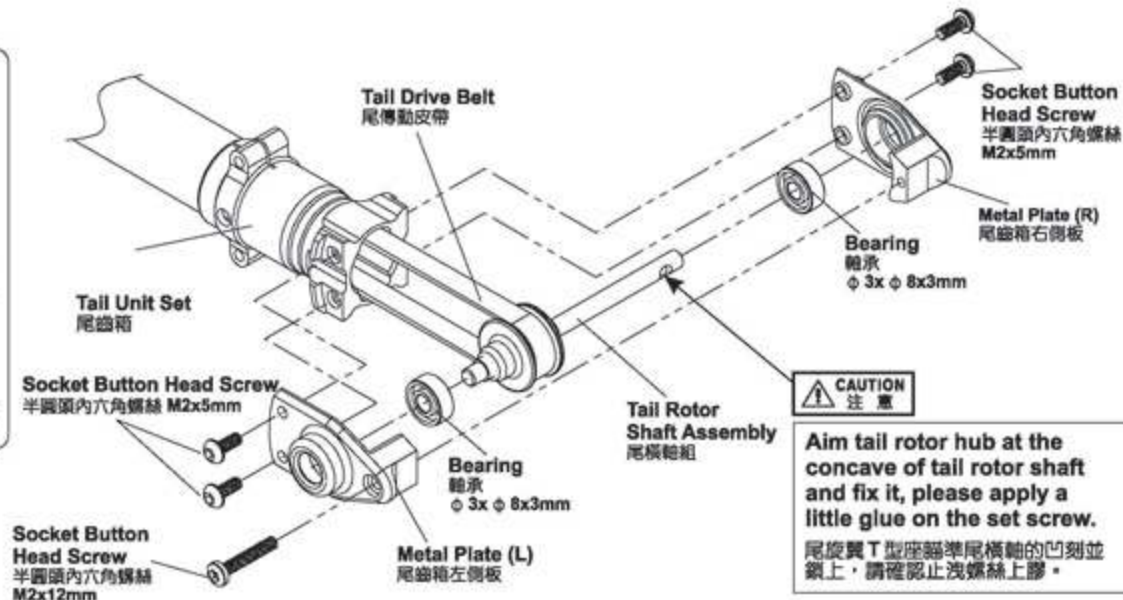

**CAUTION**  
 注意

Aim tail rotor hub at the concave of tail rotor shaft and fix it, please apply a little glue on the set screw.  
 尾旋翼T型座對準尾橫軸的凹刻並鎖上，請確認上淺螺絲上膠。



Apply a little amount of T43 thread lock when fixing a metal part.  
螺絲鎖附於金屬件請使用適量T43(螺絲膠)。

## 470HT2

**CAUTION**  
注意

For original manufactory package, if the product is already assembled by factory, please check again if screws are firmly secured and applied with some glue.

原裝零件出廠包裝如果是組裝品，請需再確認各螺絲是否鎖緊上膠。

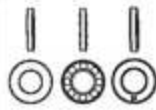

**Thrust Bearing**  
止推軸承  
( $\phi 3x\phi 6x2.8mm$ ) x 2



**Bearing**  
軸承( $\phi 3x\phi 6x2.5mm$ ) x 2



**Bearing**  
軸承( $\phi 3.5x\phi 7x2.5mm$ ) x 2



**Bearing**  
軸承( $\phi 4x\phi 7x2.5mm$ ) x 2



**Bearing**  
軸承( $\phi 1.5x\phi 4x\phi 5x2mm$ ) x 4



**Bearing**  
軸承( $\phi 2x\phi 5x2.3mm$ ) x 2



**Washer**  
華司( $\phi 2x\phi 4.8x0.6mm$ ) x 2



**Washer**  
華司( $\phi 3x\phi 4.8x0.3mm$ ) x 2



**Collar**  
尾翼軸承座襯墊  
( $\phi 4x\phi 5.1x1.6mm$ ) x 1



**Socket Collar Screw**  
圓頭內六角軸套螺絲  
(M2x6mm) x 6



**Slide Shaft**  
尾軸滑套 x 1



**Socket Collar Screw**  
圓頭內六角軸套螺絲  
(M2x10mm) x 2



**Collar B**  
尾連桿頭鋼套B( $\phi 2x\phi 3x2.5mm$ ) x 2



**Socket Button Head Screw**  
半圓頭內六角螺絲 (M2x4mm) x 2

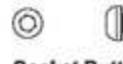

**Socket Button Head Screw**  
半圓頭內六角螺絲 (#0-80x4mm) x 4



**Linkage Ball A**  
球頭A(M2x2.5)( $\phi 4.75x7.18mm$ ) x 1

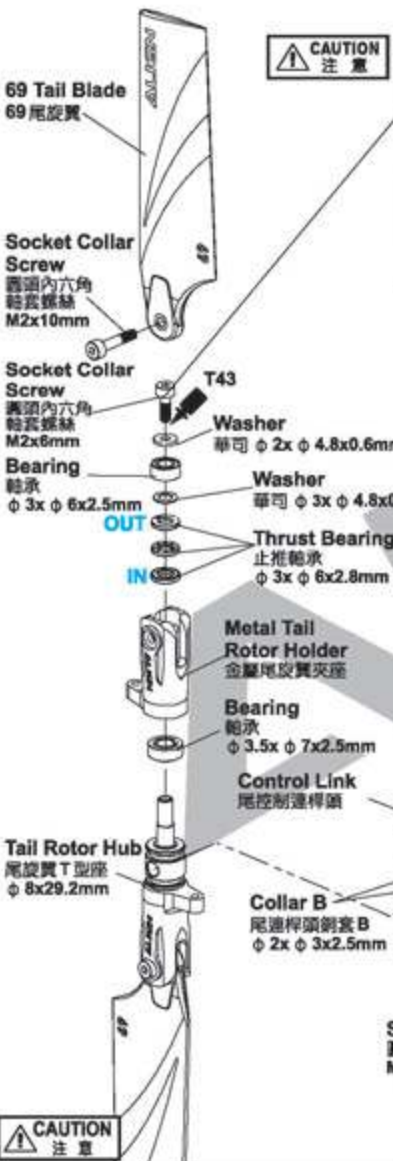

**CAUTION**  
注意

1. The Metal Tail Rotor Holder is false assembly in factory, make sure to apply little glue on screws and tighten them back appropriately before starting to fly. Suggest to use torque wrench or torque lock for tightening screws with the torque value 3.0kg.cm.

2. Make sure to tighten the screws on each side with average strength, but no unilaterally tighten, or it may causes interference during rotation.

1. 尾旋翼夾座出廠為假組裝，螺絲必須使用適量螺絲膠重新鎖附，鎖附時注意適當緊度即可，建議搭配扭力或扭力機鎖附，扭力值為3.0kg.cm。

2. 組裝尾旋翼時，上、下螺絲必須平均力道鎖附，不可單邊過緊，否則會造成干涉滑動不順暢。

**CAUTION**  
注意

While assembly the slide shaft, please use suitable amount of T43 on the thread. Please do not use R48 anaerobics retainer or other high strength glue to avoid damages while maintenance or repairs.

組立尾軸滑套時，請使用適量的T43螺絲膠在螺絲上，嚴禁使用R48高膠合性軸承膠防止膠合過緊，以避免日後拆修維護零件之損壞。

**CAUTION**  
注意

The tail rotor hub and screws are wear items, and thus should be inspected for replacement after every 100 flights. For flights with high head speed, the inspection interval should be reduced to ensure flight safety.

尾旋翼T型座和螺絲屬於飛行消耗品，建議每100趟定期檢查及更換，高主旋翼轉速飛行時，請縮短定期檢查之週數，以確保飛行安全。

**CAUTION**  
注意

Any slight binding on control link may affect tail action during flight. Please be note while tightening M2x6mm collar screw, please adjust the ball link and make sure it is operating smoothly. Apply suitable amount of T43 on the thread.

尾控制連桿頭些微干涉、動作不順暢，將影響尾舵鎖定效果，請注意鎖附M2x6mm軸套螺絲時，須調整至連桿頭可滑順轉動的程度，並使用適量T43螺絲膠固定。

**CAUTION**  
注意

After complete the tail rotor assembly, please check if it rotates smoothly.

尾旋翼組裝完成後需確認尾旋翼夾座轉動滑順。

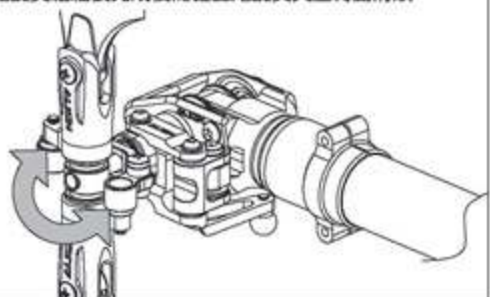

### 470HT3



**700N Linkage Rod (B)**  
700N 連桿 (B) x 2



**Carbon Tail Control Rod Sleeve**  
碳纖維控制桿套  
( $\phi 2.4 \times 5 \times 10 \text{mm}$ ) x 2



**Ball Link**  
連桿頭 x 2

### 470HT2



**Washer**  
華司 ( $\phi 2.6 \times \phi 5.8 \times 0.6 \text{mm}$ ) x 2



**Socket Screw**  
圓頭內六角螺絲 (M2x18mm) x 2



**Socket Button Head Self Tapping Screw**  
半圓頭內六角自攻螺絲  
(T2.6x10mm) x 2



**Socket Button Head Self Tapping Screw**  
半圓頭內六角自攻螺絲  
(T2x16mm) x 2

Apply a little amount of T43 thread lock when fixing a metal part.  
螺絲鎖附於金屬件時請使用適量T43(螺絲膠)。



**CAUTION**  
注意  
For original manufactory package, if the product is already assembled by factory, please check again if screws are firmly secured and applied with some glue.

原裝零件出廠包裝如果是組裝品，請需再確認各螺絲是否鎖緊上膠。

When assembling the tail boom, please aim at the fixing hole  $\phi 3$ .

裝入尾管時請注意孔對準尾管  $\phi 3$  固定孔。

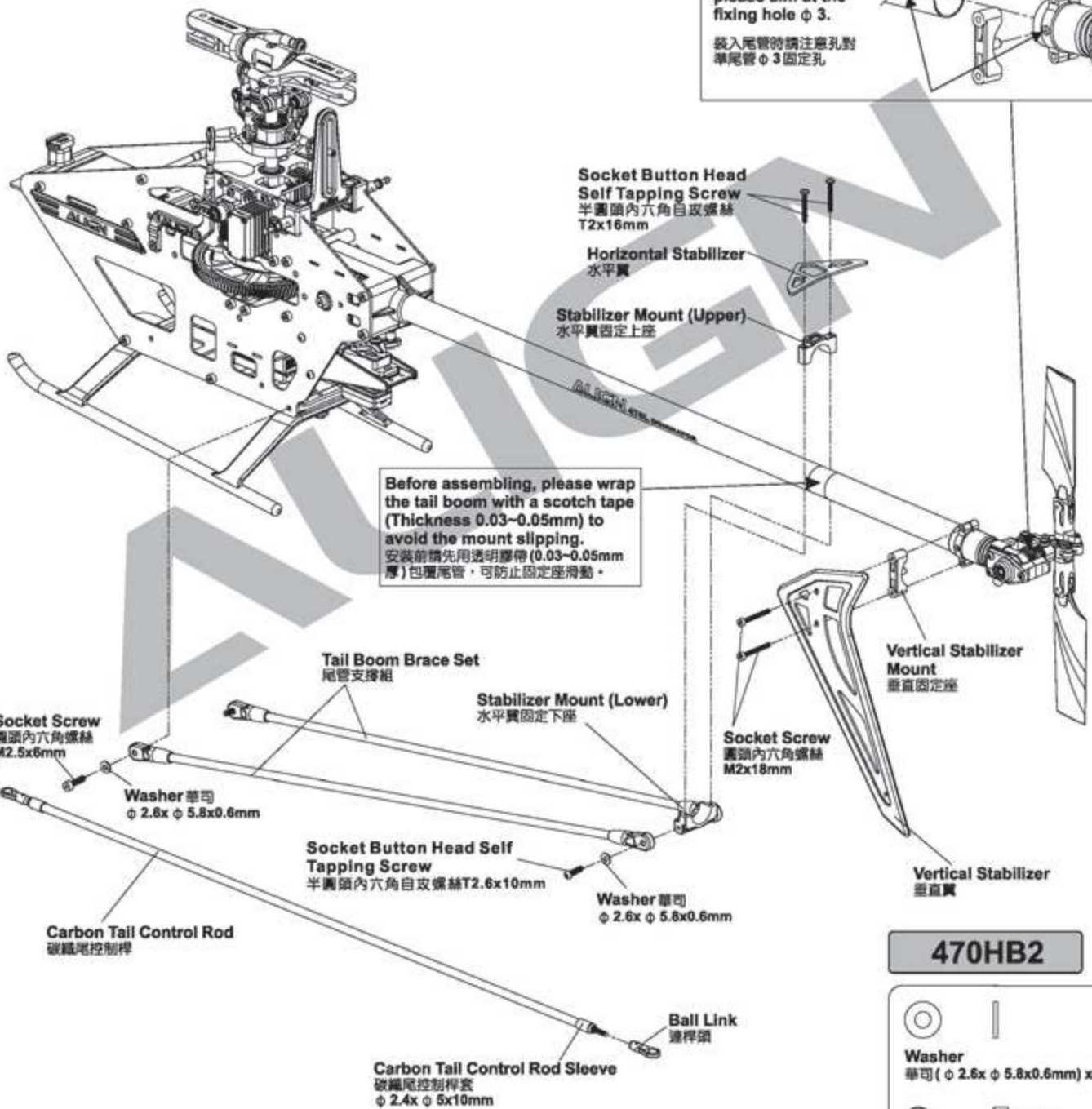
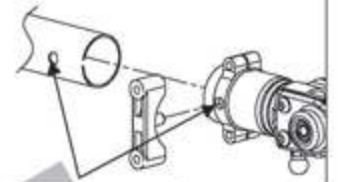

### 470HB2



**Washer**  
華司 ( $\phi 2.6 \times \phi 5.8 \times 0.6 \text{mm}$ ) x 2



**Socket Screw**  
圓頭內六角螺絲 (M2.5x6mm) x 2



# 470HH1

## Main Blade Fixing Screw

鎖主旋翼用螺絲



Socket Collar Screw  
圓頭內六角軸套螺絲 (M3x17mm) x 2



M3 Nut  
M3 防鬆螺帽 x 2

Apply a little amount of T43 thread lock when fixing a metal part.  
螺絲鎖附於金屬件請使用適量T43(螺絲膠)。



注意

For original manufactory package, if the product is already assembled by Factory, please check again if screws are firmly secured and applied with some glue.

原裝零件出廠包裝如果是組裝品，請再確認各螺絲是否鎖緊上膠。

Socket Collar Screw  
圓頭內六角軸套螺絲  
M3x17mm

When tightening the main blade fixing screw, please tighten it firmly, but not over tighten, or it may cause the damage of main blade holder and result in danger.

鎖緊主旋翼螺絲須注意適當緊度即可，過緊可能導致主旋翼夾座受損，飛行意外發生。

M3 Nut  
M3 防鬆螺帽

380 Carbon Fiber Blades  
380 碳纖維旋翼

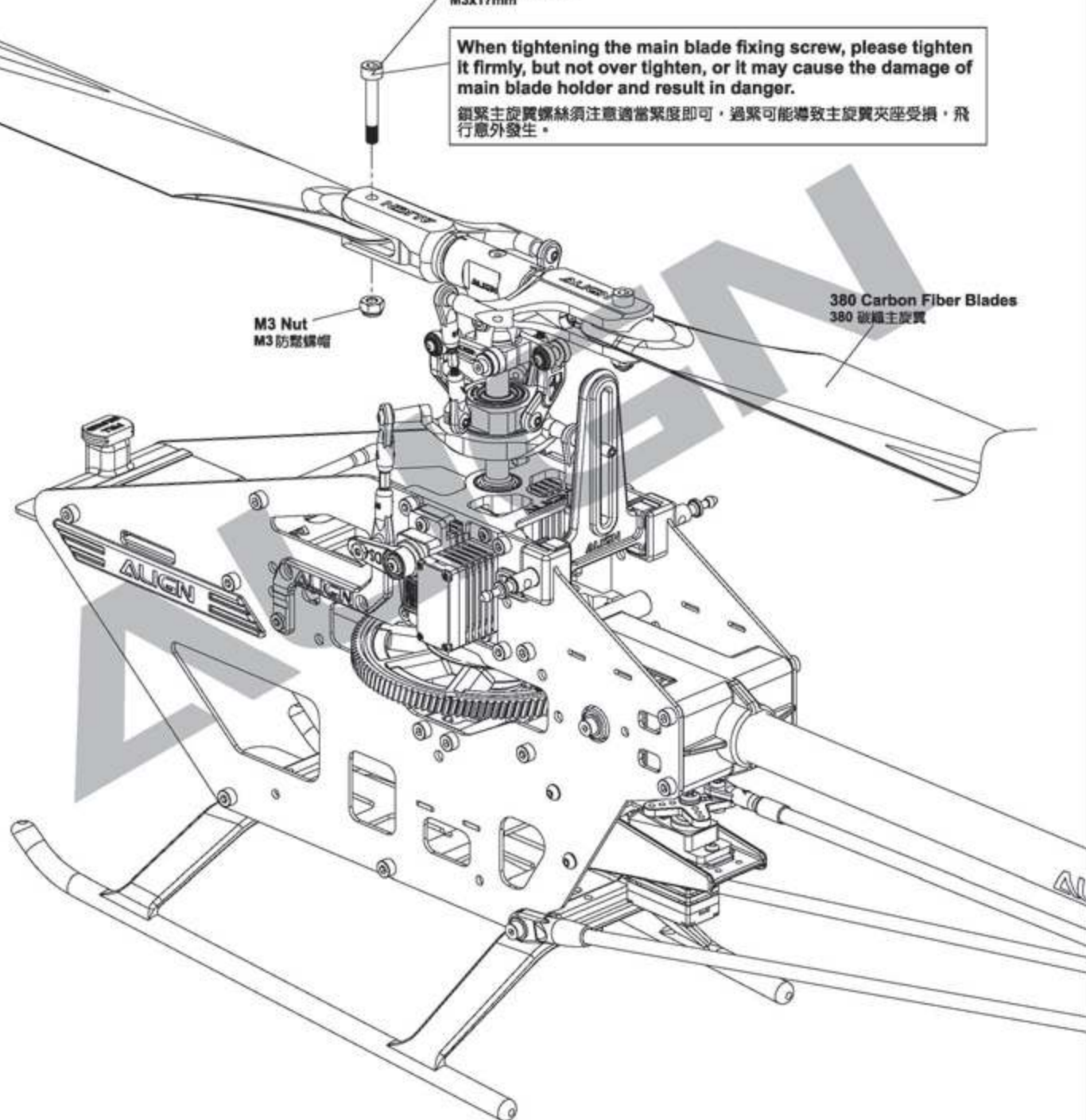

Apply a little amount of T43 thread lock when fixing a metal part.  
螺絲鎖附於金屬件請使用適量T43(螺絲膠)。

**CAUTION**  
注意

For original manufactory package, if the product is already assembled by Factory, please check again if screws are firmly secured and applied with some glue.

原裝零件出廠包裝如果是組裝品，請需再確認各螺絲是否鎖緊上膠。

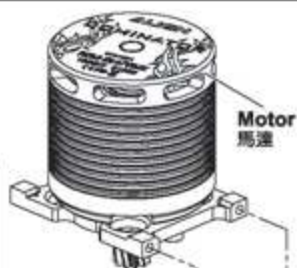

### 470HB2

Socket Screw  
圓頭內六角螺絲 (M2.5x6mm) x 2

Socket Screw  
圓頭內六角螺絲  
M2.5x6mm

M4 Washer  
M4 華司  
φ 2.6x φ 5.8x0.6mm

Motor Mount  
馬達固定座

Motor Pinion  
Helical Gear 11T  
馬達斜齒輪 11T

M3 Set Screw  
M3 止洩螺絲 M3x3mm

Motor  
馬達

### 470HB2

Socket Screw  
圓頭內六角螺絲 (M2.5x6mm) x 4

Washer  
華司  
(φ 2.6x φ 5.8x0.6mm) x 2

### 470HZ2

M3 Set Screw  
M3 止洩螺絲 (M3x3mm) x 1

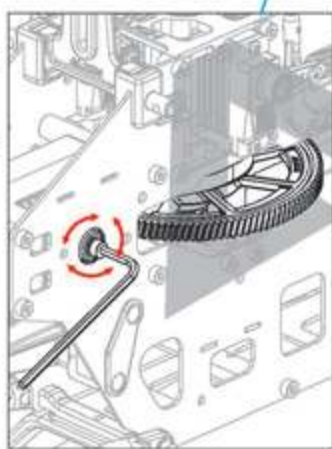
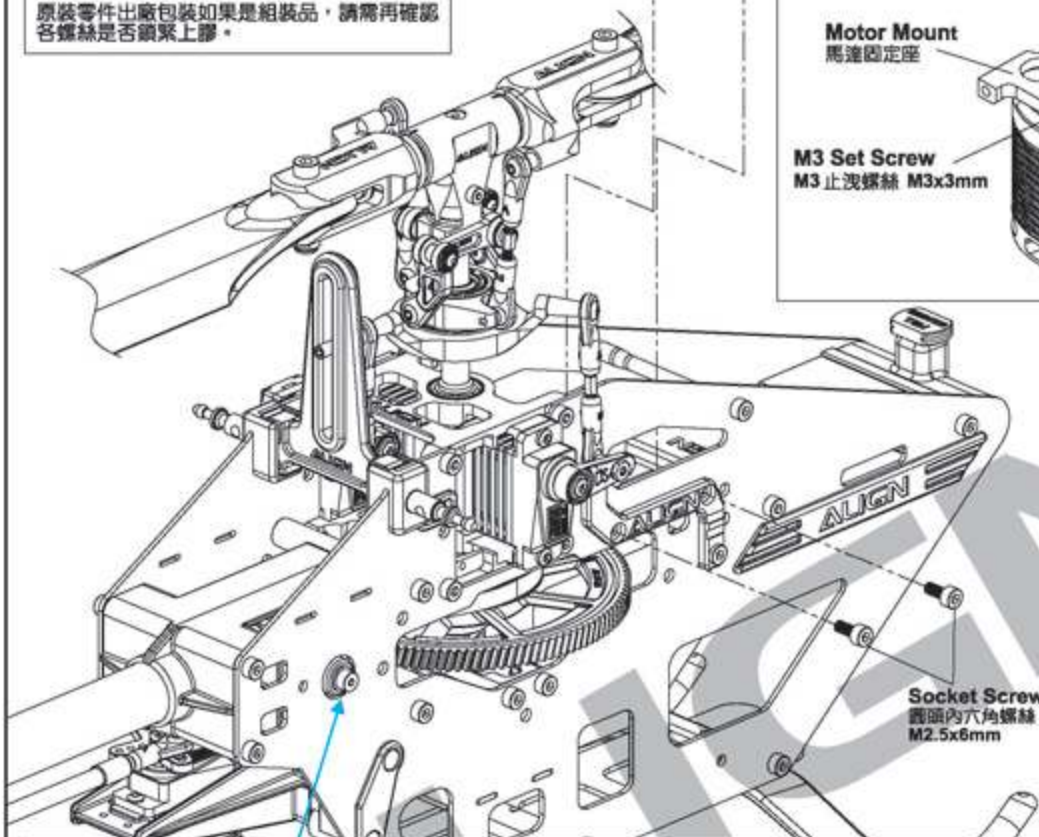

Used to adjust the belt tension by tightening or loosening the screw.  
鎖 / 放螺絲來調整皮帶鬆緊

#### BELT TENSION ADJUSTMENT SUGGESTION:

1. Adjust belt tension to ensure proper power transfer to the tail. To prevent excessive power consumption DO NOT over tighten belt.
2. Adjust both screws equally to tighten or loosen belt tension. Turn each screw approximately 1.5~2 turns to achieve the appropriate belt tension. Both sides must be rotated equally.
3. Make sure to check belt tension prior to each flight and adjust accordingly. To loosen belt tension, turn clockwise. To tighten belt tension, turn counterclockwise.

#### 皮帶鬆緊調整建議：

1. 正確的調整皮帶鬆緊度，以確保飛行動力確實傳遞至尾部；皮帶不宜過緊，以免動力損耗。
2. 鎖緊兩側皮帶壓輪的調整螺絲後，再各放1.5~2圈為最佳的皮帶鬆緊度，調整時務必將兩側的調整螺絲同時放鬆或鎖緊。
3. 每趟飛行前，請務必檢查調整螺絲的鬆緊度，順時針旋轉可將皮帶調整；逆時針旋轉則將皮帶調緊。

Set the motor pinion gear to main drive gear mesh to approximately 0.1mm to avoid excess power consumption motor burnt due to overload.

馬達前後可移動請保持兩齒輪咬合處約有0.1mm間隙，過緊咬合將造成動力損失或馬達高阻力的過載，嚴重可能導致馬達燒毀。

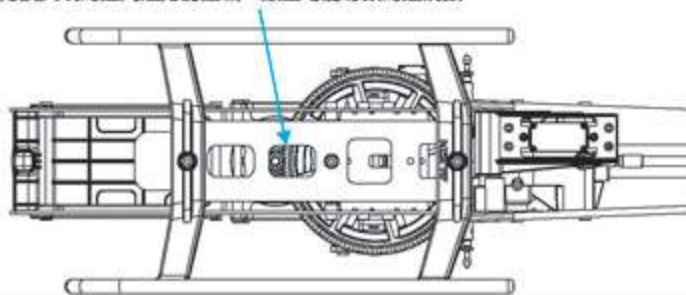

The lower edge of main gear need to be lined up with lower edge of pinion gear. This will ensure smooth meshing, and avoid interference between pinion's base and main gear which can lead to unusual wear.

馬達齒下緣必須與主齒盤下緣水平切齊，如此才能確保齒輪傳動順暢，避免馬達主齒根部與新型斜主齒輪產生異常干涉磨損。







CAUTION  
注意

### A MOUNTING ORIENTATION OF MICROBEAST PLUS MICROBEAST PLUS的安裝方向

The Microbeast PLUS unit can be mounted in nearly all possible orientations. The only restriction is that the plug connectors have to point in or against flying direction and the edges of the unit must be parallel to the rotation axis.

You have to choose whether MICROBEAST PLUS is mounted horizontally (printed surface 90 degrees to the main shaft) or vertically (printed surface in parallel with the main shaft).

Microbeast PLUS可以安裝在機體的任何位置。唯一的限制是接線口必須和飛行方向一致。您可以選擇水平安裝（印刷面與主軸呈垂直90度）、或垂直安裝（印刷面與主軸呈平行）。

### THE COLOR OF THE STATUS-LED SHOWS THE CURRENTLY SELECTED ORIENTATION:

LED指示燈狀態顯示安裝方向：

Status-LED Status-LED燈	Mounting orientation 安裝方向
Blue 藍色	Horizontal (Flat) * 水平 (平) *
Red 紅色	Vertical (on The Side) 垂直 (側面)

\* Factory Setting \* 出廠預設值



Status-LED: Blue  
Status-LED燈：藍色



Status-LED: Red  
Status-LED燈：紅色

Apply a little amount of T43 thread lock when fixing a metal part.  
螺絲鎖附於金屬件請使用適量T43(螺絲膠)。



CAUTION  
注意

For original manufactory package, if the product is already assembled by Factory, please check again if screws are firmly secured and applied with some glue.

原裝零件出廠包裝如果是組裝品，請需再確認各螺絲是否鎖緊上膠。



Please visit Align download area to get the completed instruction manual at Align website.

更多詳細的設定操作說明請至官網下載專區下載。  
<http://www.align.com.tw/beastx/>

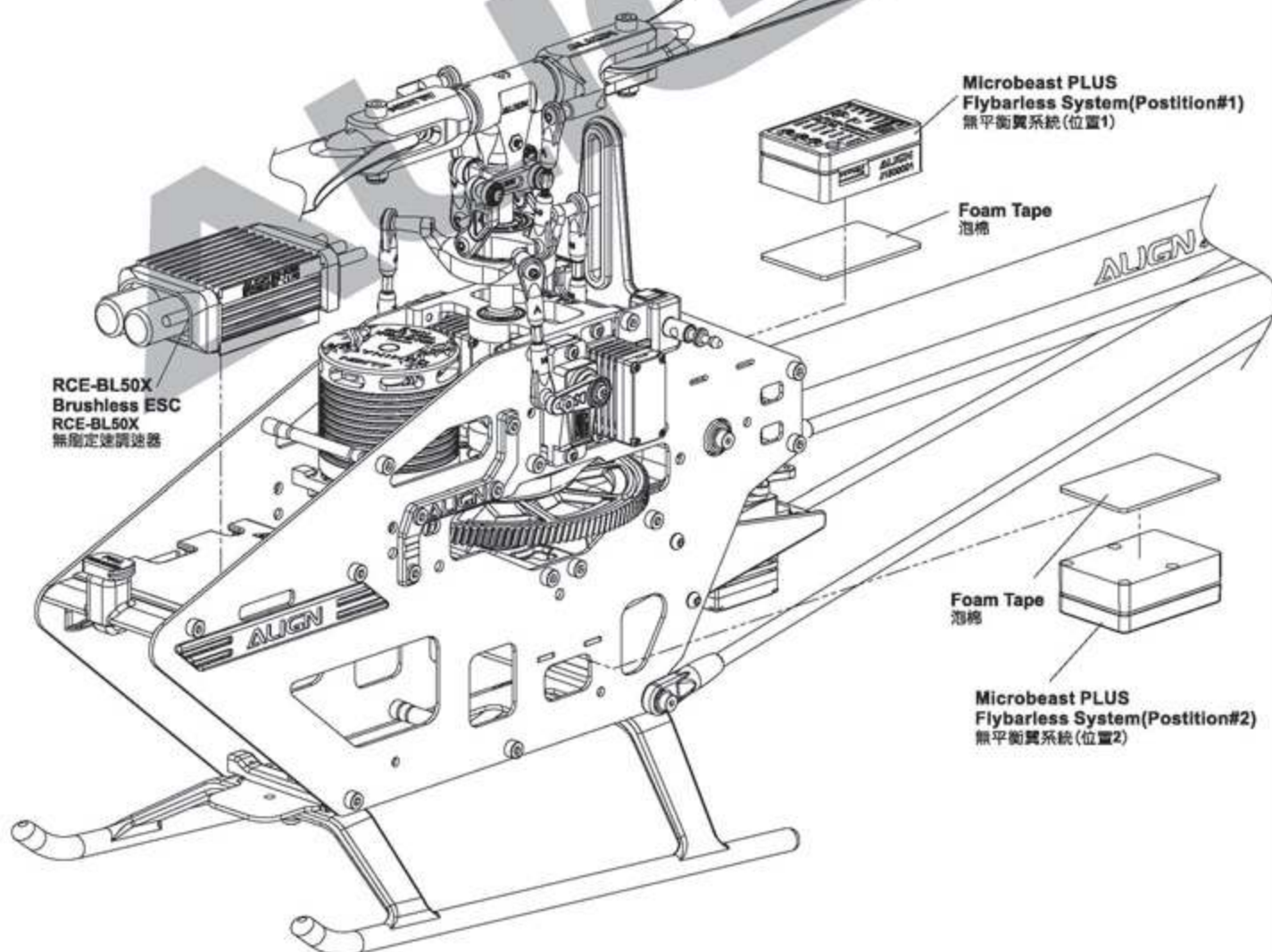

**Compatible Battery/ 適用電池**  
6S 22.2V 1,400mAh to 1,900mAh.

**Max battery size**  
可容納電池最大尺寸

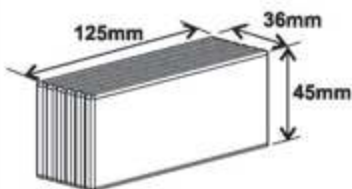

Slide the battery mounting plate along the rail until a "click" is heard to make sure the battery mounting plate is latched.

將電池固定板順著電池滑軌裝入至發出“喀答”聲響，使電池固定板卡入卡榫。

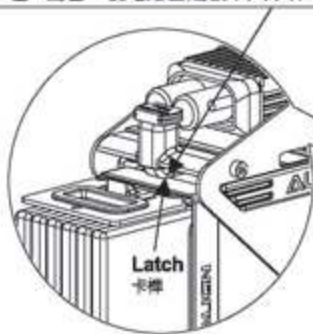

While drawing out the battery, pull this latch to allow the battery to slide out along the rail.

電池抽出時，請先將拉扣往上拉順著滑軌抽出。

Pull 拉

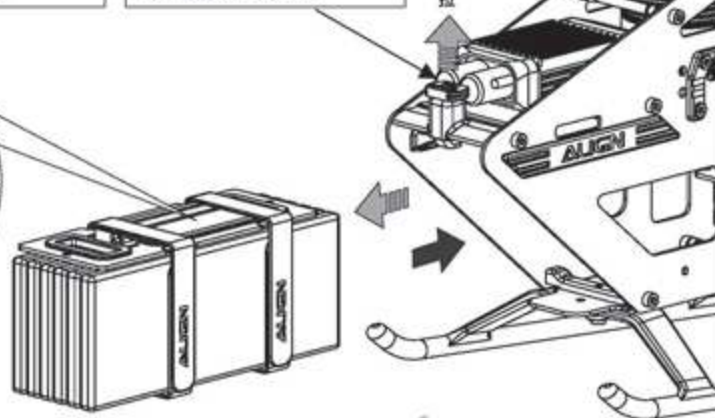

**CAUTION**  
注意

Please attach the hook & loop tape to narrow side of battery.  
魔術沾請黏貼在電池的較窄面。

**Battery Mount**  
電池固定板

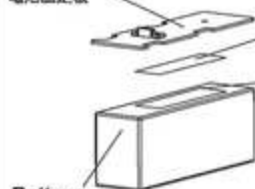

**Hook and Loop Tape (Hooked)**  
魔術沾(勾狀)

**Hook and Loop Tape (Fuzzy)**  
魔術沾(絨毛狀)



**Battery**  
電池

Use the included hook & loop strap to fix the battery in place. Start the strap 1cm below the battery mounting plate, go down along the battery until it wraps around completely. The end of the strap also needs to be 1 cm away from the battery mounting plate.

以附贈的魔術束帶來固定電池。束帶需從電池板下方1公分處，沿電池由下往上方式綁，最後束帶末端也要離電池板1公分。

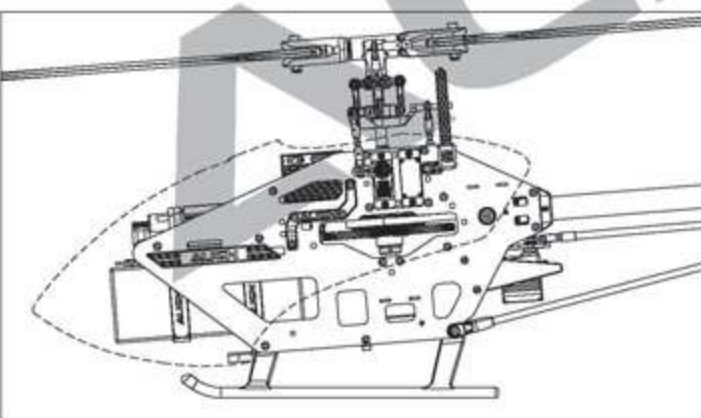

**Canopy**  
機頭罩

**Canopy Nut**  
機頭罩墊圈

Using the included foam tape on battery mount will effectively reduce vibration of canopy.

以隨附泡棉膠固定於電池座，能有效降低機頭罩震動。



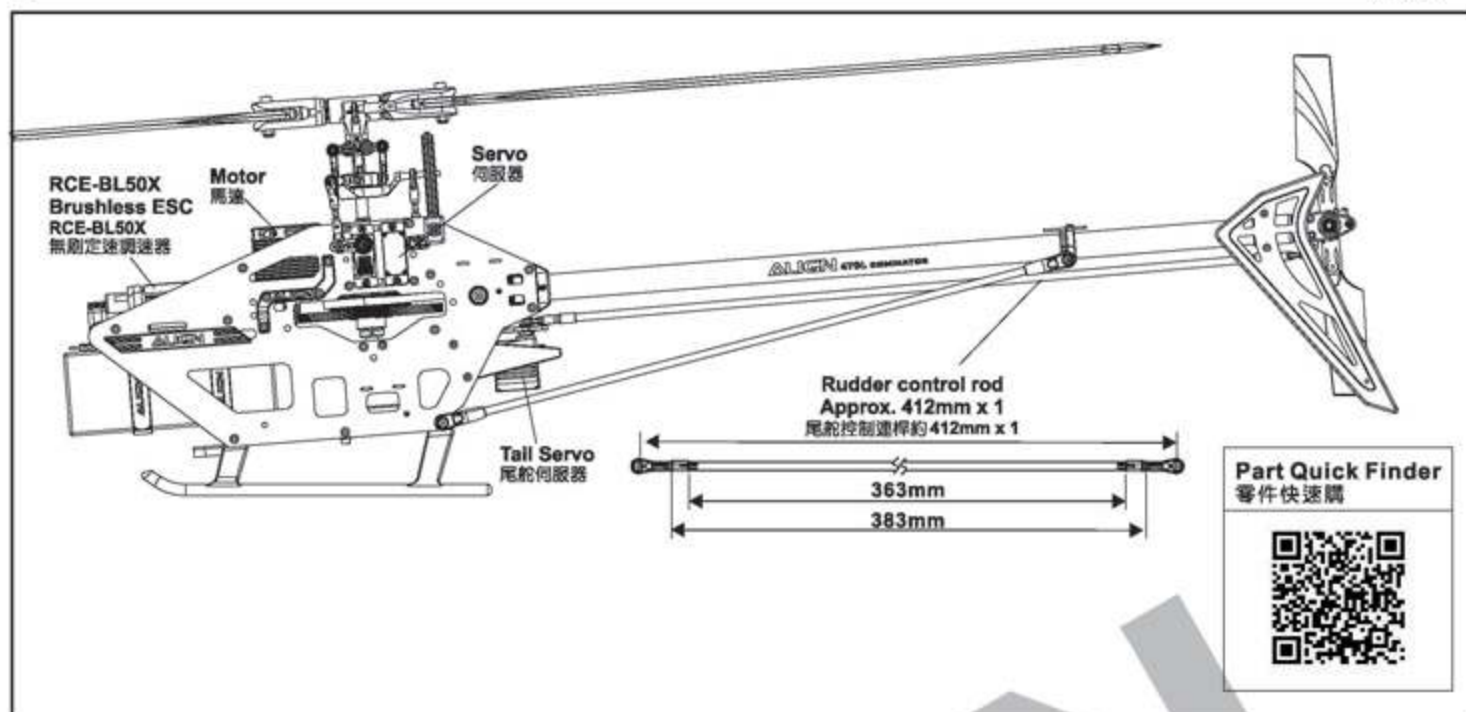

## 12. MICROBEAST PLUS FLYBARLESS MANUAL 無平衡翼系統使用說明

MICROBEAST PLUS Flybarless System as ALIGN helicopter standard equipment, must and compatible with ALIGN standard equipment including blades, servos, motor, battery and so on, please refer to flight and setup instruction in this manual.

ALIGN helicopter 標配使用 MICROBEAST PLUS 無平衡翼系統，須搭配 ALIGN 直昇機標準配件(主旋翼、伺服器、馬達)與飛行操作、設定指示。

## USER NOTICE 使用注意事項



1. If assembling and operating the helicopter without using ALIGN standard equipment, including electronic equipment & blades...etc, please make sure there is a sufficiently large and stable power supply to your helicopter. If any abnormal voltage or insufficient power supply, suggest to upgrade the flybarless system to MICROBEAST PLUS HD (Optional) for better power back up.
  2. Please refer to BEASTX MICROBEAST PLUS/HD website for MICROBEAST PLUS/HD assembly and setup instruction.
  3. Any over use, incorrect setup, assembly, modification or misuse will lead to abnormal voltage, electronic devices damage, structural interference, and insufficient power supply. Make sure to carefully check every assembly and setup refer to the manual instruction prior to every flight to prevent any unforeseen danger.
1. 安裝、操控您的直昇機時，如非使用 ALIGN 標準配件(含電子配件、主旋翼等)，請務必確定您的供電系統有足夠的供電能力，如發現電壓異常、供電不足，建議您升級使用 MICROBEAST PLUS HD 無平衡翼系統(選配)，以能確保充足、穩定的接收器電源。
  2. MICROBEAST PLUS/HD 使用、設定、接線，請參照 BEASTX MICROBEAST PLUS/HD 官方說明。
  3. 任何電子配件、零件的設定、組裝、修改或操作不良所造成的電壓異常、電子零件損壞，即可能造成供電不穩定等問題，每趟飛行前須注意仔細檢查，防止機件及電子零件故障而引發不可預期的意外。

## MANUAL LINK 設定操作連結

MICROBEAST PLUS Flybarless System is the V4.2 version out of the factory, please feel at ease using it. You can also link to BEASTX MICROBEAST PLUS/HD website to get the latest version and the latest news. And please refer to MICROBEAST PLUS V3.2.x and V4.2 instruction manual for operating and setting.

MICROBEAST PLUS 無平衡翼系統，出廠時主程式為 V4.2 版本。您也可以連結至 BEASTX MICROBEAST PLUS/HD 官網查詢，隨時更新最新版本及各項最新訊息。操作設定請同時參照 V3.2.x 版及 V4.2 版使用說明書。



Please visit Align download area to get the completed instruction manual at Align website.

更多詳細的設定操作說明請至官網下載專區下載。  
<http://www.align.com.tw/beastx/>



MICROBEAST PLUS  
FLYBARLESS SYSTEM FOR HELICOPTER

## PARTS IDENTIFICATION 各部位名稱

### MICROBEAST PLUS FLYBARLESS SYSTEM 無平衡翼系統

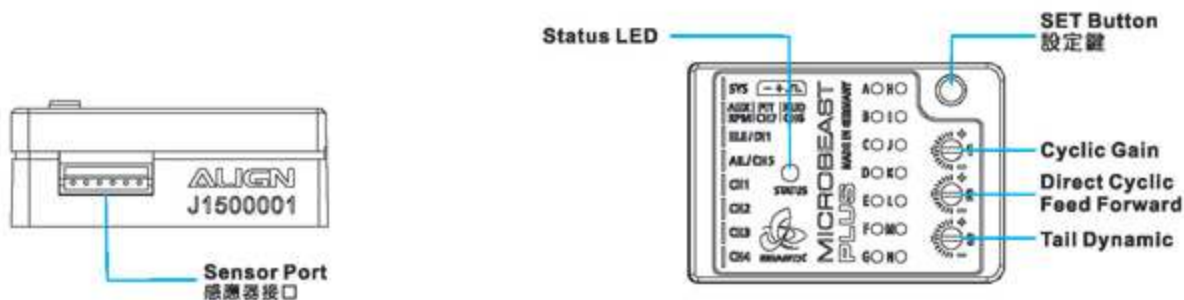

### MICROBEAST PLUS FLYBARLESS SYSTEM WIRING DIAGRAM 無平衡翼系統接線示意圖

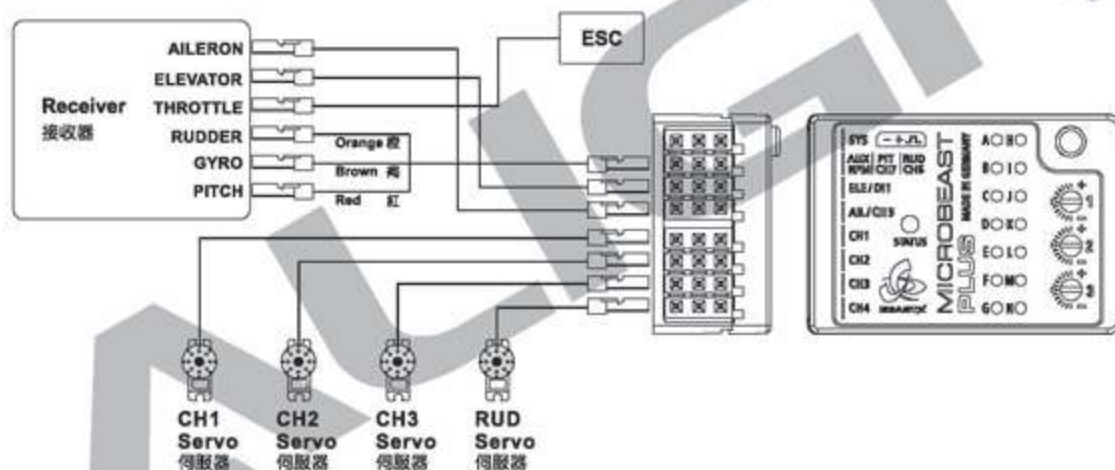

For detail connectivity, please scan QR Code then follow MICROBEAST PLUS manual.

詳細接線方式，請掃描QR Code連結至MICROBEAST PLUS說明書。



CAUTION  
注意



#### MICROBEAST PLUS HD Flybarless System(Optional) MICROBEAST PLUS HD無平衡翼系統(選配)

If assembling and operating the helicopter without using ALIGN standard equipment, including electronic equipment & blades...etc, please make sure there is a sufficiently large and stable power supply to your helicopter. If any abnormal voltage or insufficient power supply, suggest to upgrade the flybarless system to MICROBEAST PLUS HD (Optional) for better power back up. Please refer to BEASTX website for MICROBEAST PLUS HD assembly and setup instruction.

安裝、操控您的直昇機時，如非使用ALIGN標準配件(含電子配件、主旋翼等)，請務必確定您的供電系統有足夠的供電能力，如發現電壓異常、供電不足，建議您升級使用MICROBEAST PLUS HD無平衡翼系統(選配)，以能確保充足、穩定的接收器電源。MICROBEAST PLUS HD使用、設定、接線，請參照MICROBEAST PLUS HD官方說明。



To set this option is to turn on the transmitter and connect to BEC power.

**Note:** For the safety, please do not connect ESC to the brushless motor before the setting in order to prevent any accident caused by the motor running during the setting.

此項設定只要開啟發射器，接上BEC電源即可進行操作。

注意：為了安全起見，設定前請先不要將無刷調速器與無刷馬達三條線接上，以免調整時啟動馬達而發生危險。

## SERVO CONFIGURATION 伺服器配置

Following the servo configuration diagram on right, plug the servos to Gyro.

請依照右圖顯示的伺服器名稱，將伺服器接到陀螺儀。

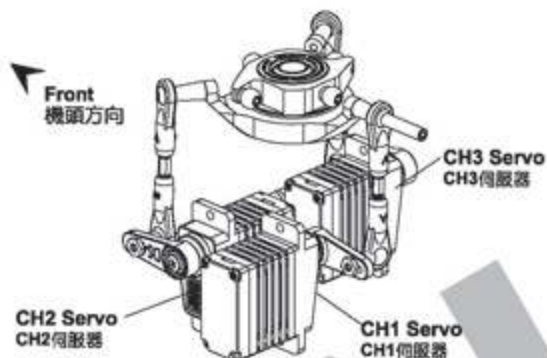

# 14. ADJUSTMENTS FOR GYRO AND TAIL NEUTRAL SETTING 陀螺儀與尾翼中立點設定調整

Turn off Revolution mixing(RVMX) mode on the transmitter, then set the gain switch on the transmitter and the gyro to non-Head lock mode, or disable gain completely. After setting the transmitter, connect the helicopter power and proceed with rudder neutral point setting.

**Note :** When connecting to the helicopter power, please do not touch tail rudder stick and the helicopter, wait for 3 seconds for gyro to enable, and the rudder servo horn should be 90 degrees to the tail control pushrod. Tail pitch slider should be halfway on the tail output shaft. This will be the standard rudder neutral point. After completing this setting, set the gain switch back to heading lock mode, with gain at around 70%.

發射器內陀螺儀設定請關閉根軸混控模式，並將發射器上的感度開關與陀螺儀切至“非鎖定模式”或將陀螺儀感度關閉。發射機設定完成後接上直昇機電源，即可進行尾舵中立點設定。

注意：當接上直昇機電源時請勿撥動尾舵搖桿或碰觸機體，待3秒陀螺儀開機完成後，尾伺服臂需與尾伺服器約成90度，尾旋翼控制組須正確置於尾橫軸約中間位置，即為標準尾舵中立點設定，設定完成後，切換至“鎖定模式”，感度設約70%左右。

## TAIL NEUTRAL SETTING 尾中立點設定

After the gyro is enable and under non-Head lock mode, correct setting photo. If the tail pitch assembly is not in the middle position, please adjust the length of rudder control rod to trim.

陀螺儀開機後，在非鎖定模式下，尾伺服器與尾Pitch控制組正確擺置位置。

若尾Pitch控制組未置中時請調整尾控制連桿的長度來修正。

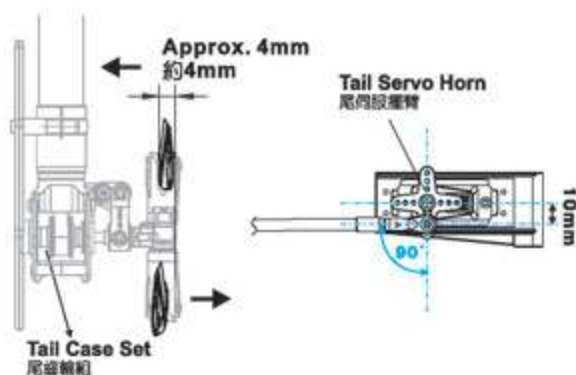

## HEAD LOCK DIRECTION SETTING OF GYRO 陀螺儀鎖定方向設定

To check the head lock direction of gyro is to move the tail counterclockwise and the tail servo horn will be trimmed counterclockwise. If it trims in the reverse direction, please switch the gyro to "REVERSE".

陀螺儀鎖定方向確認，當手搖尾部反時鐘擺動，尾伺服臂應反時鐘修正，反向時請切換陀螺儀上“鎖定反向”開關修正。

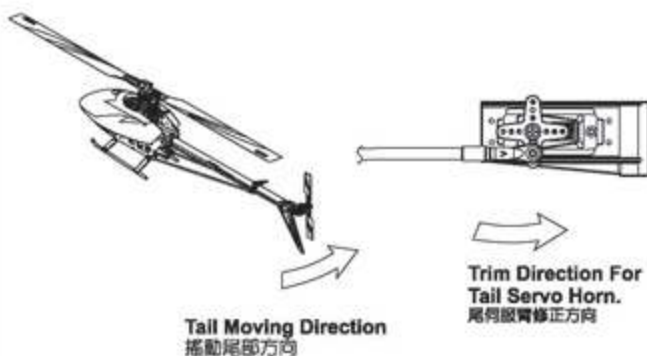



The rotational speed must set below 3,200RPM for safety to prevent any unexpected danger.  
直昇機的主旋翼有安全使用轉速範圍，飛行時不可超過3,200 RPM，超轉會導致不可預期的危險，甚至危害他人生命財產。

GENERAL FLIGHT 一般飛行模式

Stick Position at High/Throttle 100%/Pitch +9°~+12°  
搖桿高速/油門100%/Pitch +9°~+12°

Stick Position at Hovering/Throttle 65%~70%/Pitch +5°~+6°  
搖桿停懸/油門65%~70%/Pitch +5°~+6°

Stick Position at Low/Throttle 0%/Pitch -2°~0°  
搖桿低速/油門0%/Pitch -2°~0°

GENERAL FLIGHT 一般飛行模式

Throttle 油門	Pitch 螺距
5 100% High Speed 100% 高速	+9°~+12°
4 85%	
3 65%~70% Hovering 65%~70% 停懸	+5°
2 40%	
1 0% Low Speed 0% 低速	-2°~0°

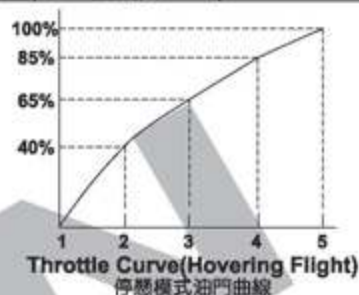

IDLE 1 : SPORT FLIGHT

Throttle 油門	Pitch 螺距
5 90%	+12°
4 85%	
3 80%	+5°
2 85%	
1 90%	-5°

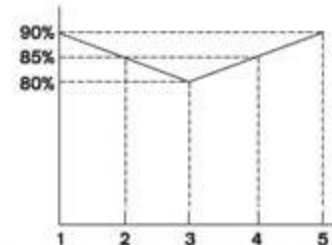

Throttle Curve (Simple Aerobatic Flight)  
空中飛行模式油門曲線

IDLE 2 : 3D FLIGHT

Throttle 油門	Pitch 螺距
5 90% High 90% 高	+12°
3 85% Middle 85% 中	0°
1 90% Low 90% 低	-12°

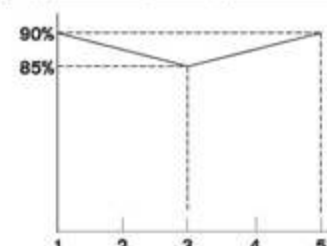

Throttle Curve (3D Flight)  
特技飛行模式油門曲線

3D FLIGHT 3D特技飛行模式

Stick Position at High/Throttle 100%/Pitch +12°  
搖桿高速/油門100%/Pitch +12°

Stick Position at Middle/Throttle 90%/Pitch 0°  
搖桿中速/油門90%/Pitch 0°

Stick Position at Low/Throttle 100%/Pitch -12°  
搖桿低速/油門100%/Pitch -12°



- Pitch range: Approx. 25 degrees.
  - If the pitch is set too high, it will result in shorter flight duration and poor motor performance.
  - Setting the throttle to provide a higher speed is preferable to increasing the pitch too high.
1. 螺距(Pitch)總行程約 25  
2. 過大螺距設定，會導致動力與飛行時間降低。  
3. 動力提升以較高轉速的設定方式，優於螺距調大的設定。



While pitch set at 0 degree, make sure to set throttle below 85%.  
螺距0度點，油門勿超過85%。



**RCM-BL470MX MOTOR 無刷馬達**

This new Brushless motor developed by the ALIGN POWER R&D TEAM, is packed with the latest, cutting edge technology available today. It features exceptional levels of high-torque power. The 470MX utilizes an 8-pole outrunner stator-rotor and unrivaled Ndfeb extra strong magnets that traditional magnets cannot compare to. Also included is a high temperature, wear-resisting, low friction, double ZZ high efficiency bearing. The 470MX will be the most revolutionary motor operating on low current amperage, and delivering high torque to RC models.

由亞拓動力團隊獨家研發出新款的無刷馬達，具有超高扭力特色，採用 12 槽矽鋼片、8 極外轉子以及傳統磁鐵無法比擬的釹鐵硼超強磁鐵，搭配高溫耐磨的雙 ZZ 超高效能精密軸承設計，電流低、扭力強，將是下一波動革命中的最具代表性的一顆星。

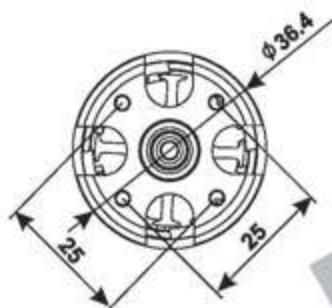
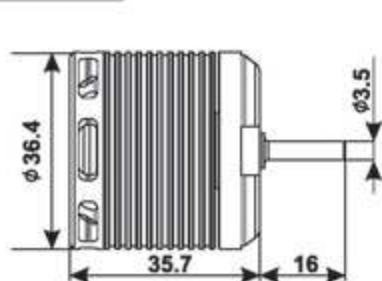
**SPECIFICATION 尺寸規格**

(Unit單位:mm)

<b>KV</b>	<b>KV值</b>	<b>1800KV(RPM/V)</b>	<b>Input Voltage</b>	<b>輸入電壓</b>	<b>6S</b>
<b>Stator Arms</b>	<b>矽鋼片槽數</b>	<b>12</b>	<b>Magnet Poles</b>	<b>磁鐵極數</b>	<b>8</b>
<b>Max Continuous Current</b>	<b>最大持續電流</b>	<b>40A</b>	<b>Max Instantaneous Current</b>	<b>最大瞬間電流</b>	<b>60A(2sec)</b>
<b>Max Continuous Power</b>	<b>最大持續功率</b>	<b>890W</b>	<b>Max Instantaneous Power</b>	<b>最大瞬間功率</b>	<b>1300W(2sec)</b>
<b>Dimension</b>	<b>尺寸</b>	<b>Shaft <math>\phi</math> 3.5x36.4x51.7mm</b>	<b>Weight</b>	<b>重量</b>	<b>Approx. 120g</b>

**PRODUCT FEATURES 產品特色**

- 5V~8.4V step-less adjustable BEC output allowing custom voltage setting to match servo specification.
- BEC output utilizing switching power system, suitable for 7.4-22.2V (2S-6S) Li battery, with continuous current rating of 3A, and burst rating of 6A.
- Three programmable throttle speed settings to support quick throttle response.
- Include soft start and governor mode.
- Small and compact PCB design for lightweight and simple installation.
- Large heat sink for optimum thermal performance.
- Highly compatible to work with 98% of all brushless motors currently on the market.
- Ultra-smooth motor start designed to run with all kinds of brushless motors.
- The power inlet utilizes a Japanese made "Low ESR" capacitor in order to provide stable power source.
- The throttle has more than 200 step resolution that provides great throttle response and control.
- 5V~8.4V 無段可調式 BEC 輸出，可依伺服器規格與所需的特性自行設定電壓。
- BEC 輸入端採用交換式電源設計，適用 7.4~22.2V(2S~6S) 鋰電，持續耐電流 3A，瞬間 6A。
- 三段可程式油門反應速度，使動力的反應隨傳隨到。
- 具緩啟動及 Governor Mode 定速功能。
- 體積小，窄型設計，安裝於機身容易。
- 有散熱片設計，可延長電變壽命。
- 超高相容性，可對應市面上 98% 無刷馬達。
- 絕佳起步設計，無論國產、進口、內轉、外轉無刷馬達皆起步順暢。
- 電池電源端採用日製 Low ESR 低阻抗電解電容，大幅提高電源之穩定性。
- 油門達 200 段以上解析度，無格數之油門感覺。

**SPECIFICATION 尺寸規格：**

<b>Model</b> 型號	<b>Continuous Current</b> 持續	<b>Peak Current</b> 瞬間	<b>BEC Output</b> BEC輸出	<b>Dimension</b> 尺寸	<b>Weight</b> 重量
RCE-BL50X	50A	70A	Output voltage: 5-8.4V step-less adjustment Continuous current 3A; Burst current 6A 輸出電壓: 5V~8.4V 無段可調式 承受電流: 持續 3A、瞬間 6A	66x32x18.5mm	62g



## WIRING ILLUSTRATION 接線示意圖



1. Good temperature situation for working at the maximum current
2. Supporting motor types: 2~10 pole in/outrunner brushless motors.
3. Supporting maximum RPM: 2 pole → 190,000 rpm ; 6 pole → 63,000 rpm.
4. Input voltage: 7.4V ~ 22.2V(2~6S Li-Po)

NOTE : 1. When setting to the Quick throttle response speed, the accelerative peak current will increase.

2. To minimize possible radio interference induced by switching power system, BEC should be installed at least 5cm away from the receiver. The use of 2.4G receiver is recommended.

1. 持續最大電流需在機體散熱良好情況下。
2. 支援馬達型式: 二極至十數極之內外轉子無碳刷馬達。
3. 支援最高轉速: 二極→190,000rpm; 六極→63,000rpm。
4. 輸入電壓: 7.4V-22.2V(2~6S Li-Po)

注意: 1. 設定為高油門反應速度時, 加速瞬間電流會有增大情形。

2. 內建 Switching BEC, 安裝時請與接收器保持至少 5cm 以上的距離以避免干擾接收器 (建議使用較穩定的 2.4G 系統接收器)。

## FUNCTIONS 產品功能

1. Brake Option - 3 settings that include Brake disabled/Soft brake/Hard brake.
2. Electronic Timing Option - 3 settings that include Low timing/Mid timing/High timing. Generally, 2 pole motors are recommended to use low timing, while 6 or more poles should use Mid timing. High timing gives more power at the expense of efficiency. Always check the current draw after changing the timing in order to prevent overloading of battery.
3. Battery Protection Option- 2 settings that include Li-ion, Li-poly High/Middle cutoff voltage protection. The default setting is high cutoff voltage protection. CPU will automatically determine cell number of input Lithium battery (2S~6S). This option will prevent over-discharge of the battery. The following reference is the guideline for setting the Battery Protection option.
  - 3-1 Li-ion/Li-poly High cutoff voltage protection-When the voltage of single cell drops to 3.2V, the first step of battery protection mode will be engaged by the ESC resulting in reduced power. The pilot should reduce the throttle and prepare landing. If the voltage of single cell drops to 3.0V, the second step of battery protection mode will be engaged resulting in power cutoff. (\*Note 1) For 22.2V/6cells Lithium battery, the full charged voltage will be approximately 25.2V. According to this input voltage, CPU will determine that this is a 3cell battery.  
First step protection: 3.2V x 6cell=19.2V  
Second step protection: 3.0V x 6cell= 18V  
When the voltage drops to 19.2V, the power will be reduced. When the voltage drops to 18V, the power will be cut off.
  - 3-2 Li-ion/Li-poly Middle cutoff voltage protection- This option is same as instruction 3-1, but when the voltage of single cell drops to 3.0V, the first step of battery protection will be engaged. When the voltage of single cell drops to 2.8V, the second step of battery protection will be engaged. (\*Note 1)  
Note 1: Second step of battery protection only works when Aircraft mode is setting to the option 4-1.  
Note: this option is only suitable for a fully charged battery pack in good working condition.
4. Aircraft Option: 3 settings that include Normal Airplane / Helicopter 1 / Helicopter 2.  
Normal Airplane Mode is used for general airplanes and gliders. When flying Helicopters, you can choose Helicopter 1 Mode, or Helicopter 2 Mode. Helicopter 1 Mode provides Soft Start feature. Helicopter 2 Mode provides Soft Start and Governor Mode.
5. Throttle response speed: 3 settings that include standard/ Medium/ Quick throttle response speed.  
The default setting is "quick speed". Use this option to adjust the setting according to flight character. For example, setting at Medium or Quick speed for 3D and powerful flight to make the power response more quickly, but note the accelerative peak current and power expense will increase.
6. BEC output voltage setting: 5V~8.4V step-less adjustment.  
This option allows custom voltage setting. Default setting is 6.5V; please adjust the voltage according to the specification of the servo (speed and resistance). Prior to entering the setup mode, a voltmeter needs to be connected to the power inlet of the receiver (as illustration) to monitor the selected voltage. The voltage is set by varying the throttle stick position from low (5V) to high (8.4V).

The voltmeter needs to be connected to any un-use inlets "+" and "-" to measure the selected voltage.  
將電壓表連接到任一未使用通道的 "+" 端及 "-" 端, 以量測所選擇的電壓。

RCE-BL50X Brushless ESC  
RCE-BL50X 無刷定速調速器



Illustration (圖1)

NOTE : Certain servos are designed to work with high voltage, while other servos are designed for lower voltage. To avoid damage to servos, please follow the servo's factory specification to determine the proper voltage setting.

注意: 部份伺服器不適合較高的電壓下操作, 請依原廠適用電壓規格設定, 避免造成伺服器燒毀。



7. Thermal Protection: When the ESC temperature reaches 80° C for any reason, it will engage the battery protection circuit, reducing power to the ESC. We recommend mounting the ESC in a location with adequate air flow and ventilation.
8. Safe Power On Alarm: When the operator turns on the ESC, it will automatically detect the transmitter signal. The ESC will emit a confirmation tone and enter normal operation mode if the throttle is set to the lowest position. If the throttle position is at full throttle, it will begin to enter Setup Mode. If the throttle is in any other position, the ESC will emit an alarm and not enter into user mode for safety precautions.
9. Aircraft Locator: If the aircraft should land or crash in an unexpected location and become lost, the pilot can enable the Aircraft Locator Option. The aircraft locator option is engaged by turning off the transmitter. When the ESC does not receive a signal from the transmitter for 30 seconds, it will start to send an alarm to the motor. The sound of the alarm will aid the pilot to locate the aircraft. This option will not work with a PCM receiver that has SAVE function enabled, or with low noise resistant PPM receivers.

1. 煞車設定: 三段選擇分為無煞車 / 軟性煞車 / 急煞車
2. 進角設定: 三段選擇分為低進角 / 中進角 / 高進角  
設定時機分為二種以及六種以上無碳刷馬達, 二種無碳刷馬達一般適用低進角, 若希望馬達轉速提高, 可將進角設定為中進角。六種以上無碳刷馬達一般適用中進角, 若希望馬達轉速提高, 可將進角設定為高進角。然而進角之調整需要注意電流之變化, 避免電池過載, 影響電池及馬達壽命。
3. 電池保護電壓設定: 二段選擇分為 Li-Ion、Li-Po 高截止電壓保護 / 中截止電壓保護  
出廠設定為高截止電壓保護; 此功能會自動判定所輸入鋰電池的 cell 數 (2~6S), 並提供使用者對該電池之放電保護, 以避免因放電電壓過低而造成電池損壞, 以下為設定值之解說:  
3-1 Li-Ion/Li-Po 高截止電壓保護: 當電壓單 cell 壓降達 3.2V 時, 電變會啟動第一階段保護, 使動力間歇性中斷, 此時使用者應將油門收小, 準備降落; 而 cell 電壓持續壓降達到 3.0V 時則會啟動第二階段保護, 完全限制動力輸出 (註 1: 僅在 4-1 選項 "一般飛機模式" 下才會啟動第二階段保護)。  
例: 以一個使用 22.2V 6cell 鋰電池之系統而言 22.2V 鋰電池充電電壓約 25.2V, 此輸入電壓 CPU 會自動判定為 6cell 鋰電。  
第一階段保護: 3.2Vx6cell=19.2V  
第二階段保護: 3.0Vx6cell=18V 當電壓降至 19.2V 時, 動力會間歇性中斷, 當壓降達到 18V 時則完全限制動力輸出。  
3-2 Li-Ion/Li-Po 中截止電壓保護: 同 3-1 功能說明, 但單 cell 壓降達到 3.0V 時, 會啟動第一階段保護, 單 cell 壓降達到 2.8V 時啟動第二階段保護 (註 1)。  
注意: 以上功能僅適用於充電, 且功能正常的鋰電池。
4. 飛機模式設定: 三段式選擇分為: 一般飛機模式 / 直昇機模式 1 / 直昇機模式 2  
使用於一般飛機或滑翔機時, 請設定於一般飛機模式, 使用於直昇機時可選擇直昇機模式 1: 具有緩啟動功能, 或直昇機模式 2: 具有緩啟動及 Governor Mode 定速功能。
5. 油門反應速度設定: 三段選擇分為標準 / 中速 / 快速  
出廠設定值為 "快速" 油門反應速度, 此功能提供使用者依所需的飛行特性來作適當的調整, 例如 3D 飛機與劇烈的 3D 直昇機飛行時可設定為中速或快速, 使動力反應更加快速、靈敏, 但須注意提高油門反應速度時, 加速瞬間電流與耗電量會有增大的情形。
6. BEC 輸出電壓設定: 5V~8.4V 無段調整  
本功能提供使用者自行設定 BEC 輸出電壓, 初始電壓為 6.5V, 使用者可依伺服器規格與所需的特性 (速度與扭力) 自行更改設定; 進入此項設定前, 請先將電壓表連接到接收器的電源端 (如圖 1), 用以監看所選擇的電壓, 設定時以油門搖桿的位置來決定輸出電壓, 油門搖桿最低為 5 伏特, 最高為 8.4 伏特, 之間的電壓值可移動搖桿的位置任意設定。
7. 溫度保護: 當電變因不良之空氣對流或是過載輸出導致溫度上升達 80°C 時, 電變會啟動溫度保護, 而使動力間歇性中斷, 建議將電變裝置在機艙內空氣對流之位置, 並實際使用電流表量測輸出電流, 以達到電變之最佳效率。
8. 開機防暴衝提醒功能: 當使用者開啟電變電源時, 系統會自動偵測發射機之設定, 如果發射機油門未置於最低點, 或未置於最高點準備進入設定模式, 馬達將不會轉動, 同時會有警音提醒。
9. 尋機功能: 當飛機降落在長草區無法以肉眼定位時, 使用者可將發射機關閉, 當電變無法接收來自接收機信號時, 電變會於三十秒後使馬達發出警音提醒, 以利定位。此功能不適用於設定了 SAVE 功能之 PCM 接收機, 或抗雜訊低之 PPM 接收機。

**SETUP MODE 設定模式**

1. Setup mode: Make sure to connect the ESC to the throttle channel of the receiver. Please refer to the user manual of your radio system. The second step is to connect the 3 power-out signal pins to the brushless motor. Before you turn on the transmitter, please adjust the throttle stick to the maximum full throttle position. Proceed to connect the battery to the ESC.  
You will hear confirmation sounds as soon as you enter the SETUP MODE.
2. Throttle stick positions in Setup mode: Setup mode includes six settings: Brake, Electronic Timing, Battery Protection, Aircraft, Throttle Response Speed and BEC output voltage. Every setting has three options. Simply place the throttle stick in the highest, middle, and lowest positions for each setting. For example, first brake setting (Hard): move the stick to the highest position. Then timing setting (mid): move the throttle stick in the middle position.
1. 進入設定模式: 將電變與接收器之油門 Channel 連接, 不同之遙控系統請參閱您遙控系統之使用手冊, 馬達之三條線亦與電變連接, 將發射器之油門搖桿推到最高點, 使之於全油門狀態, 先開啟發射器電源, 再將電源連接至電變, 進入設定模式後, 馬達將有設定模式之提示聲響。請參考程式化設定模式說明。
2. 設定模式中之動作: 設定模式共含有六項設定, 分別為煞車、馬達進角、電池保護、飛機模式、油門反應速度及 BEC 輸出電壓等設定, 詳細內容請參考產品功能之解說。每一項設定中各含三段設定, 各項設定以油門搖桿之上、中、下位置來決定其設定值。  
例如: 煞車設定時, 油門搖桿撥至最高, 則設定為急煞車, 進入第二項進角設定時, 油門搖桿撥至中間, 則設定為中進角。

Mode 設定模式	Throttle Position 油門搖桿	Low 低	Middle 中	High 高
Brake 煞車設定		● Brake Disabled(1-1) 無煞車 (1-1)	Soft Brake(1-2) 軟性煞車 (1-2)	Hard Brake(1-3) 急煞車 (1-3)
Electronic Timing 進角設定		Low-timing(2-1) 低進角 (2-1)	● Mid-timing(2-2) 中進角 (2-2)	High-timing(2-3) 高進角 (2-3)
Battery Protection 電池保護電壓設定		● High Cutoff Voltage Protection(3-1) 高截止電壓保護 (3-1)	Middle Cutoff Voltage Protection(3-2) 中截止電壓保護 (3-2)	—
Aircraft 飛機模式設定		Normal Airplane/Glider(4-1) 一般飛機 / 滑翔機 (4-1)	● Helicopter 1 (Soft Start)(4-2) 直昇機模式 1 (緩啟動功能) (4-2)	Helicopter 2 (Soft Start+ Governor Mode)(4-3) 直昇機模式 2 (緩啟動 + Governor Mode 定速功能) (4-3)
Throttle Response Speed 油門反應速度設定		Standard(5-1) 標準 (5-1)	Medium Speed(5-2) 中速 (5-2)	● Quick Speed(5-3) 快速 (5-3)
BEC Output Voltage BEC 輸出電壓設定		5.0V	● 6.5V	8.4V

Note: "●" Default Setting  
註: "●" 表示出廠設定值

Chart A  
表 A



## ESC START-UP INSTRUCTION 開機使用模式

<p>Ensure the throttle stick is at the lowest position. Switch on transmitter. 打開電源，油門搖桿置於最低點，準備進入使用操作模式</p> 	<p>Connect battery power to ESC 變速器接上電源，馬達響音提示</p>  Power on sound 馬達響音  Transmitter detected sound 系統偵測OK	<p>Current Settings Indicator Beeps 升空使用模式響音提示</p> <p>First mode sound (Brake) Second mode sound (Timing) Third mode sound (Battery protection) Fourth mode sound (Aircraft) Fifth mode sound (Throttle response speed) No sound for BEC output voltage</p> <p>第一種模式響音提示(煞車) 第二種模式響音提示(齒角) 第三種模式設定響音提示(電池保護) 第四種模式響音提示(飛機模式) 第五種模式響音提示(油門反應速度) BEC輸出電壓不會以響音提示</p>
--	---	---

## CURRENT SETTINGS INDICATOR BEEPS EXPLANATION 開機模式設定響音提示說明

<p>First Beep Group Brake Status 第一個響音 煞車設定狀態提示</p> <ul style="list-style-type: none"> <li>1 beep = Brake disabled = 無煞車</li> <li>2 beeps = Soft brake = 軟性煞車</li> <li>3 beeps = Hard brake = 急煞車</li> </ul>	<p>Second Beep Group Electronic Timing 第二個響音 齒角設定狀態提示</p> <ul style="list-style-type: none"> <li>1 beep = Low timing (apply to 2 pole inrunner motors) = 低齒角 (適合2級內轉子馬達)</li> <li>2 beeps = Mid timing (apply to 6 pole in/out runner motors) = 中齒角 (適合6級內外轉子馬達)</li> <li>3 beeps = High timing (apply to high power output) = 高齒角 (適用於高功率輸出)</li> </ul> <p>High-timing/big power/power expense 高齒角模式有較大功率與耗電特性</p>	<p>Third Beep Group Battery protection Cutoff 第三個響音 電池保護設定狀態提示</p> <ul style="list-style-type: none"> <li>1 beep = High cutoff voltage protection = 高截止電壓保護</li> <li>2 beeps = Middle cutoff voltage protection = 中截止電壓保護</li> </ul>	<p>Fourth Beep Group Aircraft Status 第四個響音 飛機模式設定狀態提示</p> <ul style="list-style-type: none"> <li>1 beep = Normal airplane/Glider = 一般飛機/滑翔機</li> <li>2 beeps = Helicopter 1 (Soft start) = 直昇機模式1(緩啟動功能)</li> <li>3 beeps = Helicopter 2 (Soft start + Governor Mode) = 直昇機模式2(緩啟動功能+Governor Mode) (定速功能)</li> </ul>	<p>Fifth Beep Group Throttle Response 第五個響音 油門反應速度設定狀態提示</p> <ul style="list-style-type: none"> <li>1 beep = Standard = 標準</li> <li>2 beeps = Medium speed = 中速</li> <li>3 beeps = Quick speed = 快速</li> </ul>
--	---	--	---	--

## INSTRUCTIONS ON AIRCRAFT MODE SETTINGS 飛機模式設定使用說明

**Normal Airplane/Glider Mode (Option 4-1):**  
This option is applied to general airplanes and gliders.

**Helicopter 1 Mode (Option 4-2):**  
This option provides a soft start feature and is applied to Helicopters for Normal, Idle Up 1, or Idle Up 2 modes. Please note that the sensitivity of the gyro should be set lower when flying in Idle Up 1 or Idle Up 2 modes if tail hunting (wag) occurs due to higher rotor speed.

**Helicopter 2 Mode (Option 4-3):**  
This option supports soft start as well as Governor Mode features and is applied to Helicopters for Idle Up 1 and Idle Up 2 modes (not suitable for Normal Flight Mode). When Governor Mode is in use, the throttle should be set between 75% and 85%. Again if tail wag occurs, lower the sensitivity of the gyro to eliminate the hunting effect. The Governor Mode may not work properly in cases of insufficient rotor speed (due to improper gear ratio), poor battery discharge capability, and improper setting of gyro sensitivity and the blade pitch, etc. Please make sure all the proper adjustments have been done when using Governor Mode.





一般飛機模式(選項4-1): 適用於一般飛機及滑翔機。

直昇機模式1(選項4-2): 具有緩啟動功能，適用於Normal、Idle1、Idle2等飛行模式，當切換至Idle1或Idle2模式，如有較高轉速造成陀螺儀有輕微的追蹤現象，此時應將陀螺儀的感度設定分別降低。

直昇機模式2(選項4-3): 具有緩啟動及Governor Mode定速功能，適用於Idle1、Idle2特技飛行模式(不適合Normal飛行模式下選用)，選擇定速功能時，油門應定速在75%~85%之間，如果飛行時發現有輕微的追蹤現象時，應降低陀螺儀的感度；由於轉速不足(齒比搭配不當)，電池效能不佳，陀螺儀感度設定不當，Pitch設定錯誤，皆會導致無法發揮定速的功能，甚至產生尾部偏擺的情形，所以選擇此模式時應針對相關條件進行確認。

## SETUP MODE 程式化設定模式

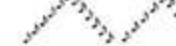
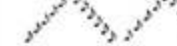
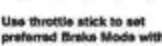
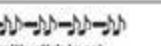
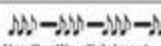
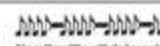
Minimum 4 channel radio is required 四動以上標準發射器均可執行設定

<p>Place the throttle stick to the highest position. Switch on transmitter. 打開電源，油門搖桿置於最高點準備進入程式化功能設定模式</p> 	<p>Connect battery to ESC 變速器接上電源，馬達響音提示</p>  Power on sound 馬達響音  Enter Setup Mode 進入設定模式	<p>Throttle channel adjustment process, the highest position acknowledge sound. 油門校正程序最高點響音</p> 	<p>Place the throttle stick to the lowest position. Position, the lowest position acknowledge sound. 油門搖桿置於最低點響音</p> 	<p>Use throttle stick to set preferred Brake Mode within the 5 tones. A confirmation sound will kick in when finish. 於5音節之音響響音時以發動油門選擇設定，設定音節參照A圖為設定，結束時將有連續響音提示</p> 
<p>Use throttle stick to set preferred Timing Mode within the 5 tones. (Refer to Chart A) A confirmation sound will kick in when finish. 於5音節之音響響音時以發動油門選擇設定，設定音節參照A圖為設定，結束時將有連續響音提示</p> 	<p>Use throttle stick to set preferred Battery Protection Mode within the 5 tones. (Refer to Chart A) A confirmation sound will kick in when finish. 於5音節之音響響音時以發動油門選擇設定，設定音節參照A圖為設定，結束時將有連續響音提示</p> 	<p>Use throttle stick to set preferred Aircraft Mode within the 5 tones. (Refer to Chart A) A confirmation sound will kick in when finish. 於5音節之音響響音時以發動油門選擇設定，設定音節參照A圖為設定，結束時將有連續響音提示</p> 	<p>Use throttle stick to set preferred Throttle Response Speed Mode within the 5 tones. (Refer to Chart A) A confirmation sound will kick in when finish. 於5音節之音響響音時以發動油門選擇設定，設定音節參照A圖為設定，結束時將有連續響音提示</p> 	<p>Use throttle stick to set preferred BEC Output Voltage Mode within 5 tones. (Refer to Chart A) A confirmation sound will kick in when finish. 於5音節之音響響音時以發動油門選擇設定，設定音節參照A圖為設定，結束時將有連續響音提示</p> 



**PLEASE PRACTICE SIMULATION FLIGHT BEFORE REAL FLYING** 飛行前請事先熟練電腦模擬飛行

A safe and effective practice method is to use the transmitter flying on the computer through simulator software sold on the market. Do a simulation flight until you familiarize your fingers with the movements of the rudders, and keep practicing until the fingers move naturally.

1. Place the helicopter in a clear open field ( Make sure the power OFF ) and the tail of helicopter point to yourself.
2. Practice to operate the throttle stick (as below illustration) and repeat practicing "Throttle high/low", "Aileron left/right", "Rudder left/right", and "Elevator up/down".
3. The simulation flight practice is very important, please keep practicing until the fingers move naturally when you hear operation orders being call out.

在還沒瞭解直昇機各動作的操控方式前，嚴禁實機飛行，請先進行電腦模擬飛行的練習，一種最有效、最安全的練習方式，就是透過市面販售的模擬軟體，以遙控器在電腦上模擬飛行，熟悉各種方向的操控，並不斷的重複，直到手指可熟練的控制各個動作及方向。

1. 將直昇機放在空曠的地方(確認電源為關閉)，並將直昇機的機尾對準自己。
2. 練習操作遙控器的各搖桿(各動作的操作方式如下圖)，並反覆練習油門高/低、副翼左/右、升降舵前/後及方向舵左/右操作方式。
3. 模擬飛行的練習相當重要，請重複練習直到不需思索，手指能自然隨著喊出的指令移動控制。



Mode 1	Mode 2	Illustration 圖示
		<ul style="list-style-type: none"> <li>Move Left 左移</li> <li>Move Right 右移</li> <li>Rotate Left 左翻</li> <li>Rotate Right 右翻</li> </ul>
		<ul style="list-style-type: none"> <li>Fly Forward 前進</li> <li>Fly Backward 後退</li> <li>Forward Rotate 前翻</li> <li>Backward Rotate 後翻</li> </ul>
		<ul style="list-style-type: none"> <li>Ascent 上升</li> <li>Descent 下降</li> </ul>
		<ul style="list-style-type: none"> <li>Turn Right 右旋</li> <li>Turn Left 左旋</li> </ul>

**FLIGHT ADJUSTMENT AND NOTICE** 飛行調整與注意



- ⊙ Check if the screws are firmly tightened.
- ⊙ Check if the transmitter and receivers are fully charged.
- ⊙ 再次確認→螺絲是否鎖固?
- ⊙ 發射器和接收器電池是否足勁。



If there are other radio control aircraft at the field, make sure to check their frequencies and tell them what frequency you are using. Frequency interference can cause your model, or other models to crash and increase the risk of danger. 假使飛行場有其他遙控飛機，請確認他們的頻率，並告知他們您正在使用的頻率，相同的頻率會造成干擾導致失控和大大地增加風險。



**STARTING AND STOPPING THE MOTOR** 啟動和停止馬達



First check to make sure no one else is operating on the same frequency. Then place the throttle stick at lowest position and turn on the transmitter. 首先確認附近沒有其他相同頻率的使用，然後打開發射器將油門搖桿推到低點。

- Check the movement.
- 動作確認



**ON! Step1**  
First turn on the transmitter.  
先開啟發射器

**ON! Step2**  
Connect to the helicopter power  
接上直昇機電源



Check if the throttle stick is set at the lowest position. 確認油門搖桿是在最低的位置。

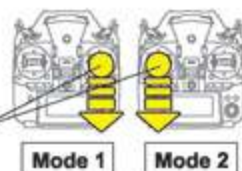

- ⊙ Are the rudders moving according to the controls?
- ⊙ Follow the transmitter's instruction manual to do a range test.
- ⊙ 方向舵是否隨著控制方向移動?
- ⊙ 根據發射器說明書進行距離測試。



**OFF! Step3**  
Reverse the above orders to turn off.  
關閉電源時請依上述操作動作反執行。



This procedure is best performed on soft surfaces such as grass. The use of rubber skid stopper is recommended on hard surface to prevent vibration feedback from the ground to Gyro, resulting in over-corrections.

將直升機置於柔軟地面上，建議硬地起飛腳架裝上避震墊圈。避免升空前腳架與過硬的地面震動太大反饋至機身上的陀螺儀，影響無平衡系統升空前過度修正。

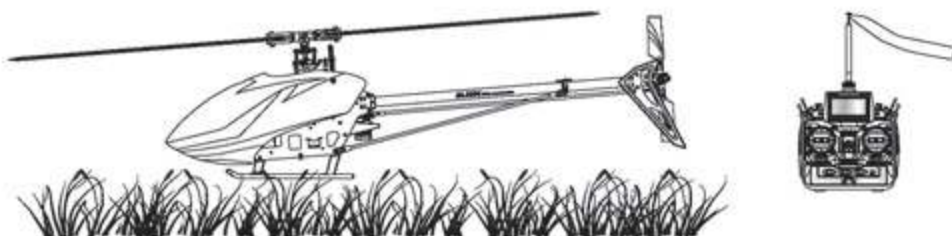

If swashplate should tilt prior to lift off, do not try to manually trim the swashplate level. This is due to vibration feedback to the Gyro, and will disappear once helicopter lifts off the ground. If manual trim is applied, helicopter will tilt immediately after liftoff.

直昇機離地前，十字盤可能因陀螺儀受震動的反饋，使十字盤有傾斜的情形，此時請勿刻意將十字盤修正為水平狀態，此現象只要離地升空時立即解除，可平穩升空；若刻意將十字盤修正為水平時，反而會造成感應器過度修正，一離地即偏往修正方向的危險。

## MAIN ROTOR ADJUSTMENTS 主旋翼雙槳平衡調整

1. Before adjusting, apply a red piece of tape on one blade, or paint a red stripe with a marker or paint to identify on blade.
2. Raise the throttle stick slowly and stop just before the helicopter lifts-off ground. Look at the spinning blades from the side of the helicopter.
3. Look at the path of the rotor carefully. If the two blades rotate in the same path, it does not need to adjustment. If one blade is higher or lower than the other blade, adjust the tracking immediately.

1. 調整前先在其中一支主旋翼的翼端，貼上有顏色的貼紙或畫上顏色記號，方便雙槳調整辨識。
2. 慢慢的推起油門搖桿到高點並且停止，在飛機離開地面前，從飛機側邊觀察主旋翼轉動。
3. 仔細觀察旋翼軌跡(假如兩支旋翼移動都是相同軌跡，則不需要調整；可是如果一支旋翼較高或較低產生“雙槳”的情形時，則必須立刻調整軌跡)。

- a. When rotating, the blade with higher path means the pitch is too big. Please shorten ball link for regular trim.
- b. When rotating, the blade with lower path means the pitch is too small. Please lengthen ball link for regular trim.

- a. 旋翼轉動時較高軌跡的主旋翼表示螺距(PITCH)過大，請調短連桿修正。
- b. 旋翼轉動時較低軌跡的主旋翼表示螺距(PITCH)過小，請調長連桿修正。



Tracking adjustment is very dangerous, so please keep away from the helicopter at a distance of at least 10m.

調整軌跡非常危險，請於距離飛機最少10公尺的距離。

Incorrect tracking may cause vibrations. Please repeat adjusting the tracking to make sure the rotor is correctly aligned. After tracking adjustment, please check the pitch angle is approx.  $+5\sim 6^\circ$  when hovering.

不正確的旋翼軌跡會導致震動，請不斷重複調整軌跡，使旋翼軌跡精準正確。在調整軌跡後，確認一下Pitch角度在停旋時應為大約 $+5\sim 6^\circ$ 。

Color Mark 有標示記號的主旋翼



## FLIGHT ADJUSTMENT AND NOTICE 飛行調整與注意

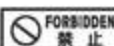

⊙ Do not attempt to grab or make contact with the helicopter while the main blades are in motion and keep your eyes away from the helicopter. During take-off, landing, and flight, be sure to keep the helicopter away from all obstacles. Operators must stand at least 10 meters away from the helicopter to avoid injury caused by loose parts due to improper assembly or any unforeseen dangers.

⊙ 嚴禁用手抓取運行中的直昇機，並禁止將直昇機對著眼睛，當主旋翼轉動後，或起飛/試飛時，務必遠離障礙物，站立位置必需距離10公尺以上，避免因人 為組裝不當造成零件脫落，而引發不可預期的財物及人員損傷。



- ⊙ Make sure that no one or obstructions in the vicinity.
- ⊙ For flying safety, please carefully check if every movement and directions are correct when hovering.
- ⊙ 確認鄰近地區沒有人和障礙物。
- ⊙ 為了飛行安全，您必須先確認停懸時各項操控動作是否正常。



Do not attempt until you have some experiences with the operation of helicopter.  
嚴禁無熟練操控飛行經驗者操控飛行。



## STEP 1 THROTTLE CONTROL PRACTICE 油門控制練習

◎When the helicopter begins to lift-off the ground, slowly reduce the throttle to bring the helicopter back down. Keep practicing this action until you control the throttle smoothly.

◎當直昇機開始離地時，慢慢降低油門將飛機降下。持續練習飛機從地面上升和下降直到您覺得油門控制很順。

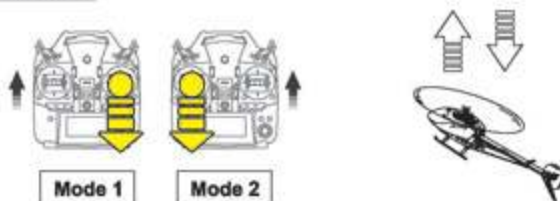

## STEP 2 AILERON AND ELEVATOR CONTROL PRACTICE 副翼和升降控制練習

1. Raise the throttle stick slowly.  
2. Move the helicopter in any direction back, forward, left and right, slowly move the aileron and elevator sticks in the opposite direction to fly back to its original position.

1. 慢慢升起油門搖桿。  
2. 使直昇機依指示：移動向後/向前/向左/向右，慢慢的反向移動副翼和升降搖桿並將直昇機回到原來位置。

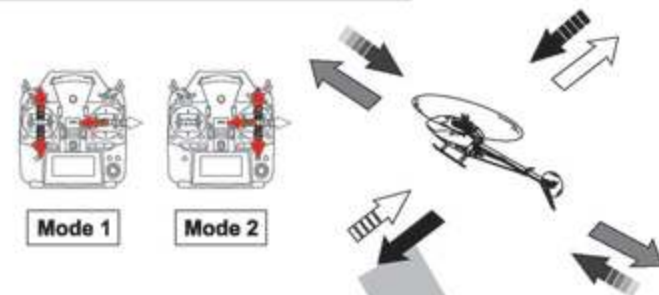

◎If the nose of the helicopter moves, please lower the throttle stick and land the helicopter. Then move your position diagonally behind the helicopter 10M and continue practicing.

◎If the helicopter flies too far away from you, please land the helicopter and move your position behind 10M and continue practicing.

◎當直昇機機頭偏移時，請降低油門並且降落，然後移動自己的位置到直昇機的正後方10公尺再繼續練習。

◎假如直昇機飛離你太遠，請先降落直昇機，並到直昇機後10公尺再繼續練習。

## STEP 3 RUDDER CONTROL PRACTICING 方向舵操作練習

1. Slowly raise the throttle stick.  
2. Move the nose of the helicopter to right or left, and then slowly move the rudder stick in the opposite direction to fly back to its original position.

1. 慢慢升起油門搖桿。  
2. 將直昇機機頭移動左或右，然後慢慢反向移動方向舵搖桿並將直昇機飛回原本位置。

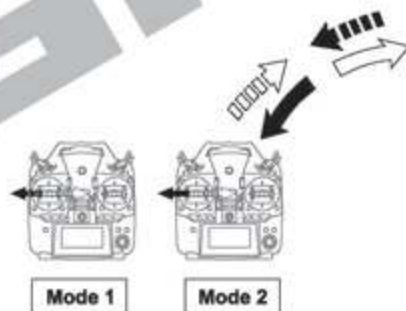

## STEP 4

After you are familiar with all actions from STEP1 to 3, draw a circle on the ground and practice within the circle to increase your accuracy.

當你覺得STEP1-3動作熟悉了，在地上畫圓圈並在這個圓圈的範圍內練習飛行，以增加你操控的準確度。

◎You can draw a smaller circle when you get more familiar with the actions.

◎當你更加習慣操作動作，你可以畫更小的圓圈。

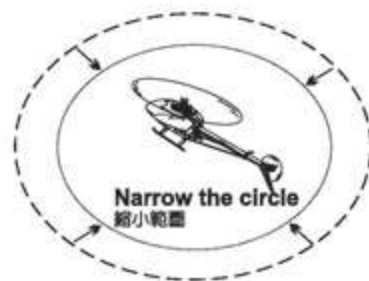

## STEP 5 DIRECTION CHANGE AND HOVERING PRACTICE 改變直昇機方向和練習停旋

After you are familiar with STEP1 to 4, stand at side of the helicopter and continue practicing STEP1 to 4. Then repeat the STEP1 to 4 by standing right in front of the helicopter.

當你覺得STEP1-4動作熟悉了，站在面對直昇機側邊並繼續練習STEP1-4。之後，站在直昇機機頭右邊重複步驟練習。

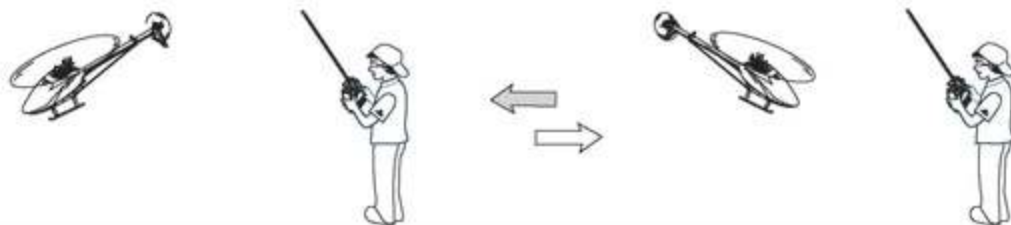

	Problem 狀況	Cause 原因	Solution 對策
Blade Tracking 雙槳平衡	Tracking is Off 雙槳	Pitch linkage rods are not even length PITCH連桿長度調整不平均	Adjust length of ball link. 調整連桿球頭長度
Hover 停懸	Head speed too low 主旋翼轉速偏低	Excessive pitch 主旋翼的PITCH偏高	Adjust ball link to reduce pitch by 4 to 5 degrees. 調整連桿球頭調低Pitch約+4~5度
		Hovering throttle curve is too low 停懸點油門曲線過低	Increase throttle curve at hovering point on transmitter (around 60%) 調高停懸點油門曲線(約60%)
	Head speed too high 主旋翼轉速偏高	Not enough pitch 主旋翼的PITCH偏低	Adjust ball link to increase pitch by 4 to 5 degrees. 調整連桿球頭調高Pitch約+4~5度
		Hovering throttle curve is too high 停懸點油門曲線過高	Decrease throttle curve at hovering point on transmitter (around 60%) 調低停懸點油門曲線(約60%)
Rudder Response 尾舵反應	Drifting of tail occurs during hovering, or delay of rudder response when centering rudder stick. 停懸時尾翼向某一邊偏移，或撥動方向舵並回復到中立點時，尾翼產生延遲，無法停頓在所控制位置上。	Rudder neutral point improperly set 尾中立點設定不當	Reset rudder neutral point 重設尾中立點
	Tail oscillates (hunting, or wags) at hover or full throttle 停懸或全油門時尾翼左右來回搖擺。	Rudder gyro gain too low 尾舵陀螺儀敏感度偏低	Increase rudder gyro gain 增加尾舵陀螺儀敏感度
		Rudder gyro gain too high 尾舵陀螺儀敏感度偏高	Reduce rudder gyro gain 降低尾舵陀螺儀敏感度

If above solution does not resolve your issues, please check with experienced pilots or contact your Align dealer.

※在做完以上調整後，仍然無法改善情況時，應立即停止飛行並向有經驗的飛手諮詢或連絡您的經銷商。



Thank you for purchasing and supporting ALIGN products.

The Align Team is dedicated to you by innovating and developing new RC Helicopters, Multicopters, and FPV Racing Quads to provide a more diversified experience for our customers. Visit our website at [www.align.com.tw](http://www.align.com.tw) for the latest news, information, and updates about our extensive line of products for the RC enthusiasts.

### Good Flying!

再次感謝您對亞拓系列商品的喜愛與支持，您的肯定是對我們最大的認同。

亞拓團隊秉持創新研發的精神，開發遙控直昇機／多軸飛行機／穿越機系列商品，提供給您體驗更多樣化的飛行樂趣。您可以透過下列連結，隨時瞭解亞拓的最新動態，以及各項訊息分享。

祝福您有一個愉快的飛行體驗。



**ALIGN T-REX Helicopter** 亞拓遙控直昇機  
<http://www.align.com.tw/helicopter-en/>



**ALIGN Multicopter** 亞拓多軸飛行機  
<http://www.align.com.tw/multicopter-en/>



**ALIGN FPV Racing Quad** 亞拓穿越機  
<http://www.align.com.tw/multicopter-en/mr25/>



**ALIGN Website** 亞拓官網  
<http://www.align.com.tw>



**ALIGN Shopping Cart** 亞拓購物車  
<http://shop.align.com.tw/index.php?language=en>



**ALIGN Quick Finder** 亞拓零件快速購  
[Http://shop.align.com.tw/partfinder.php?language=en](http://shop.align.com.tw/partfinder.php?language=en)



**ALIGN FaceBook**  
<https://www.facebook.com/Align-Corporation-194493419543/?ref=mf>



**ALIGN Instagram**  
<https://instagram.com/aligncorporation/>



**ALIGN YouTube**  
[https://www.youtube.com/channel/UCaPj\\_K5DNo7HSmP1eytUvMQ](https://www.youtube.com/channel/UCaPj_K5DNo7HSmP1eytUvMQ)



**ALIGN Youku**  
<http://i.youku.com/u/UMTQ0NjEwNjczNg==>



**ALIGN**

# ALIGN

## Specifications & Equipment/規格配備:

Length/機身長:755mm

Height/機身高:210mm

Main Blade Length/主旋翼尺寸:380mm

Tail Blade Length/尾旋翼尺寸:69mm

Main Rotor Diameter/主旋翼直徑:850mm

Tail Rotor Diameter/尾旋翼直徑:181mm

Motor Pinion Gear/馬達齒輪:11T

Main Drive Gear/傳動主齒輪:121T

Autorotation Tail Drive Gear/尾傳動主齒:56T

Tail Drive Gear/尾翼傳動齒:15T

Drive Gear Ratio/齒輪傳動比:11:1:3.73

Flying Weight(without battery)/全配重(不含電池): Approx. 860g

