



Titan Dynamics

[Titan Dynamics Webpage](#)

[Visit our Facebook page](#)

[Join our Discord server](#)

# Titan Dynamics – Micro Talon

<https://www.titandynamics.org/3dhanger/p/titan-micro-talon>

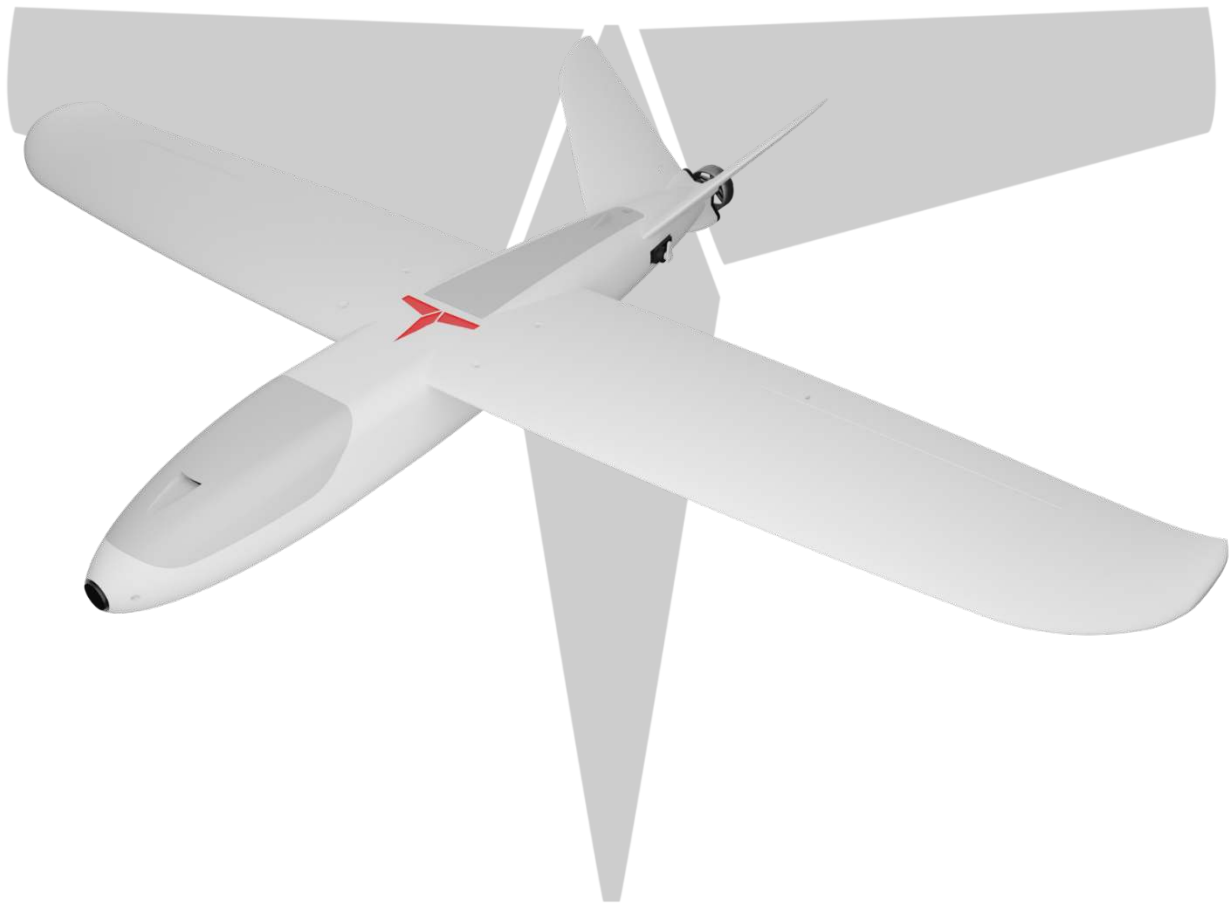

Build & User Manual

Revision 1.3



## Contents

Section 1: Model Information.....	3
Section 2: Model Specifications & Performance.....	4
Section 3: Required Build Materials.....	5
Section 4: 3D printing .....	6
4.1: Things to know before you start printing. ....	6
4.2: Part Orientation .....	7
4.3: Tuning "hole horizontal expansion".....	9
4.4: Bed Adhesion and warping.....	9
Section 5: Assembly of 3D Printed Parts.....	11
Section 6: Final Setup & Tuning Tips.....	14
Section 7: Additional Images .....	15



## Section 1: Model Information

Introducing the Titan Micro Talon: A lightweight, long range-able, ultra-portable 900mm wingspan FPV platform. Featuring a flight envelope ranging from high speed acrobatics to high efficiency cruise. Whether it's flying around the park or shooting for a mountain peak, the Micro Talon is the tool for the job. The fuselage features a magnetic front canopy along with a hinged rear hatch with ample cooling and room for the electronics and battery. The wings and tail feature flush mounted servos for the flaperons and tailerons. The Micro Talon is capable of 140km max range and 2+ hours of flight time when using a 7000mah 4S2P 18650 paired with a T-motor F90 (1300kv) and 7x5 prop. With higher kv 6S setups, a top speed of 250km/h is easily attainable.

Printable on smaller 180x180x180mm printers fully support-less. If you're just getting started with 3D printed planes, this is the one for you!

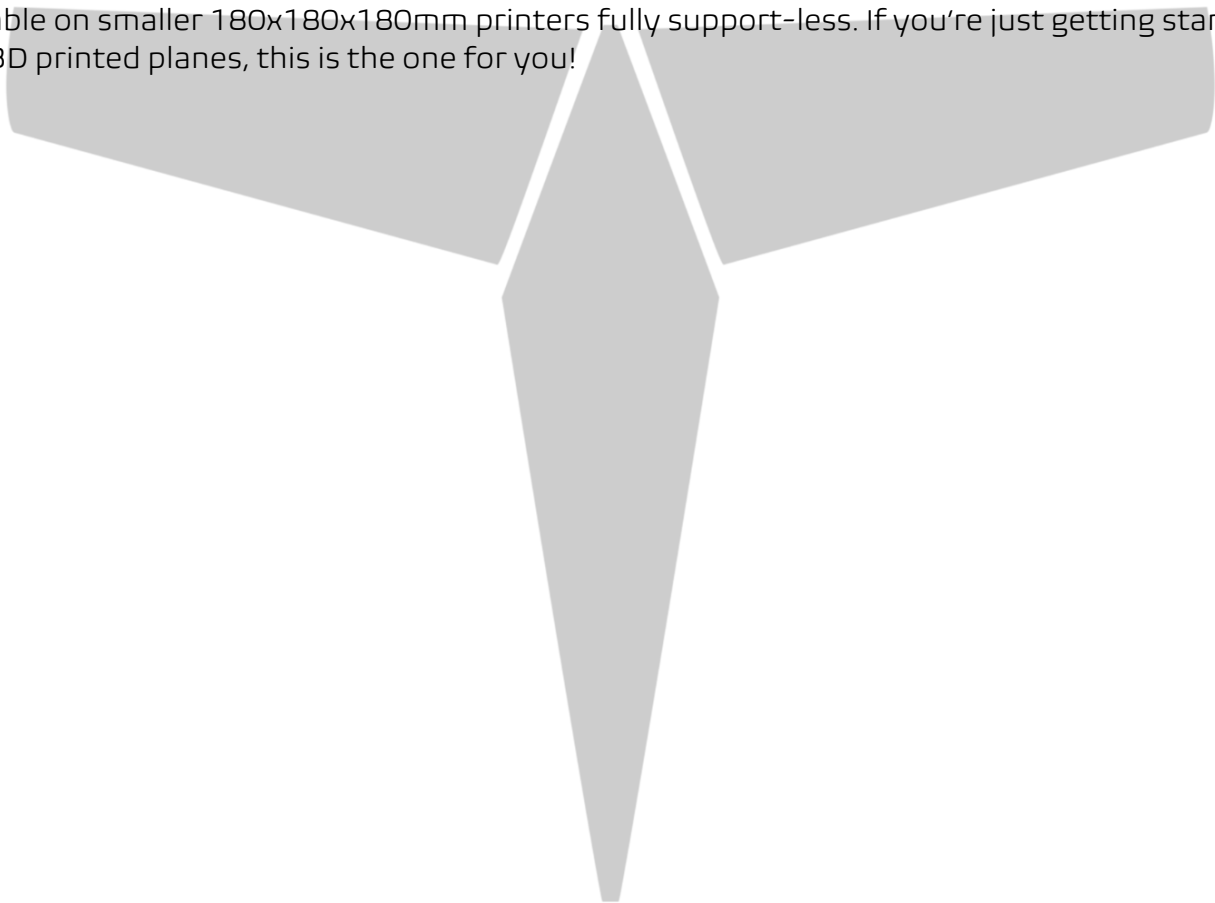



## Section 2: Model Specifications & Performance

### General Stats:

- Wingspan: 900mm
- Wing area: 1136cm<sup>2</sup>
- Maximum take-off Weight: 1.7kg
- Efficiency: 0.56 Wh/km
- Cruise speed: 70-95kph
- Recommended prop diameter: 7 inches

### Aerodynamic Properties:

- Root airfoil: NACA 3410
- Tip airfoil: NACA 3410
- Root chord: 150mm
- Tip chord: 61mm
- Average Chord: 111mm
- Root incidence: 3°
- Tip incidence: 0°
- Aspect ratio: 7.09
- Max L/D: 11.5
- Dihedral: 0°
- Sweep: 3°

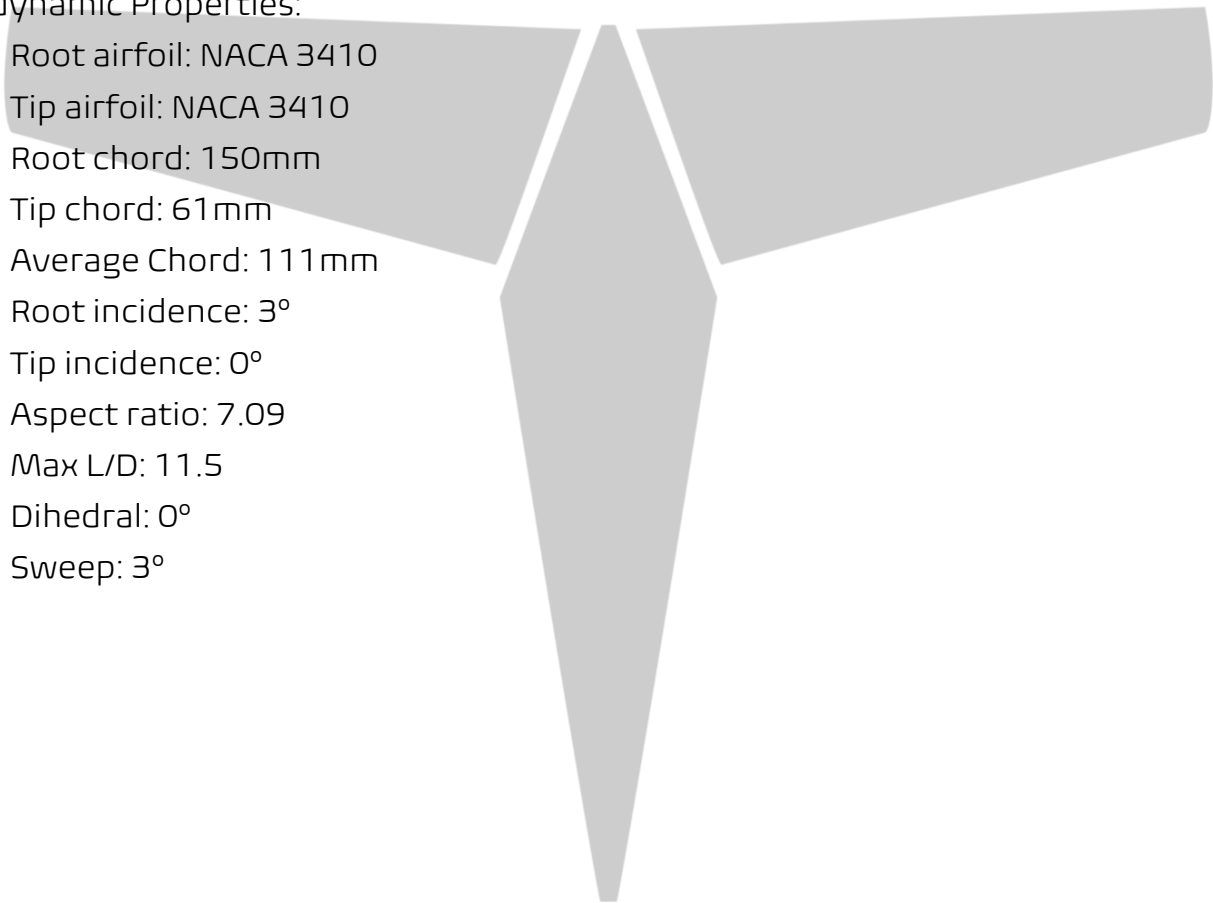



## Section 3: Required Build Materials

### Spars needed:

- (1) 8x500 (main wing spar)
- (1) 4x420 (secondary wing spar)
- (4) 2x200 (wingtip support + aileron hinge)
- (2) 2x120 (vtail hinge)

### Recommended motor & prop:

16-19mm mounting pattern

Ideal motor: TMotor F90 1300kv. Other motors lighter than 70g can be used. 2212 and 2216 are too big! Aim for 2203-2506 size

5-7 inch propeller (we used 7x5)

### Recommended electronics:

TBS crossfire / ELRS

5.8ghz analog or digital video (19x19 camera)

Matek F405-WMN / WTE flight controller or similar

Matek M8Q-5883 GPS/Compass or similar

35a BLHeli ESC

(4) Emax ES08MAII servos

Battery: Anything from a 2000mah 4S/6S Lipo to 4S1P 4,200mah Li-Ion

### Misc:

Polymaker Polylite prefoamed LWPLA

Polycarbonate or other high-temp filament for the motor mount

Medium CA glue

180x180x180 minimum size print bed

Control horns ([this one](#)).

M3 threaded inserts (max 6mm height)

M3 bolts of various sizes

6x3mm magnets



## Section 4: 3D printing

### 4.1: Things to know before you start printing.

1. Titan Dynamics strongly recommends using Polymaker Polylite prefoamed LWPLA for the best results. This filament is much easier to tune your printer for and has less stringing than active foaming filaments.
2. You likely will not get good results unless your printer is well maintained and calibrated, we would suggest learning how to check and adjust your printer to perform at its absolute best before starting. This website has useful guides: <https://teachingtecht.github.io/calibration.html#intro>.
3. All the below guidance should be taken as a starting point only. Print a test piece and check things like retraction settings and fitment of the carbon rods in the wings for yourself as every printer is different. If the carbon rods are too tight, increase the "Hole Horizontal Expansion" setting in Cura (or the equivalent setting in other slicers).
4. All our models are designed to be printed predominantly in LW-PLA filament. All fuselage, tail, and wing parts should be printed in LW-PLA.

There are 3 levels of infill / wall settings that we recommend for the LWPLA parts:

1. Maximum efficiency: 3% cubic subdivision, single wall
2. Balanced efficiency and strength: 5% cubic subdivision, single wall
3. Maximum strength: 8% cubic subdivision, single wall

**WE RECOMMEND PRINTING MICRO TALON WITH 5% CUBIC SUBDIVISION INFILL**

#### Notes:

- For the best flight characteristics and maximum range, LWPLA parts should be printed with single wall and 3% cubic subdivision infill.
- Cubic subdivision infill can be increased to 5 or 8% to increase durability, but this will have an impact on maximum payload capacity (battery), and range by extension. We recommend and use 3% cubic subdivision infill as it has been tested to survive 6.4G in flight, but some may desire greater general durability when handling/carrying the model around etc. It will still break if you crash it!
- Because the fuselage takes the most abuse during landings, some may choose to just print the fuselage sections in higher infill. Using a higher infill just for the fuselage (4%-8%) can greatly increase the longevity of the plane without as much of a weight penalty as printing the entire plane in high infill.

Polycarbonate, PETG or other high-temp filament should be used for the motor nacelle caps and wing bay covers.

- High temp Polycarbonate or PETG parts should be double wall and high infill (25%).



We recommend using the newest version of Ultimaker Cura. [This link](#) can be used to download our own slicer profile.

## 4.2: Part Orientation

It is necessary to orient each part correctly on the build plate to avoid disconnected overhangs. Take care when doing this as the entire model is designed to be printed with no supports. If you orient some parts wrong, the print will fail. It may also be necessary to rotate and carefully position some parts to fit within the build area on smaller printers.

Examples for part orientation:

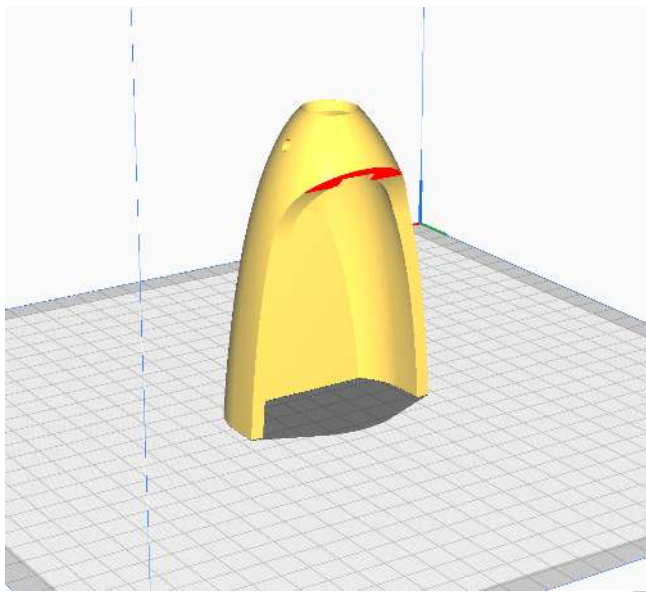

Fuse0

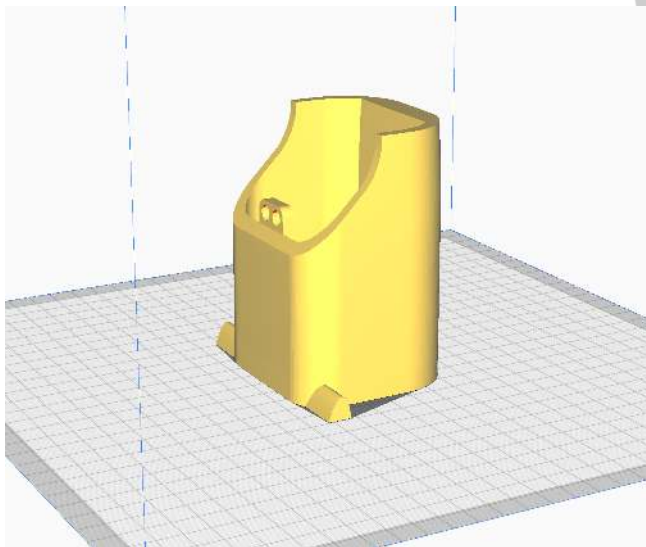

Fuse1

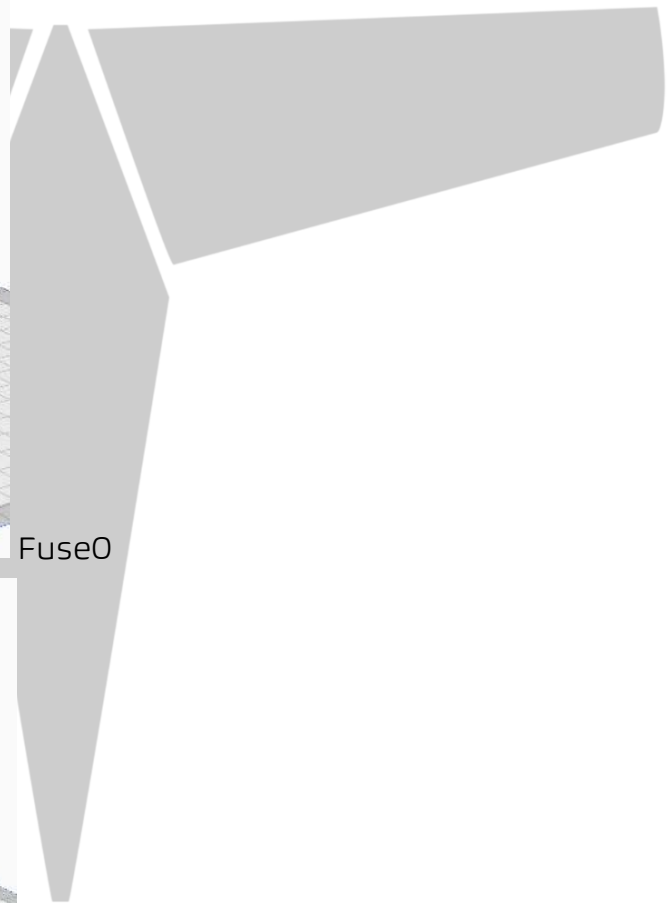

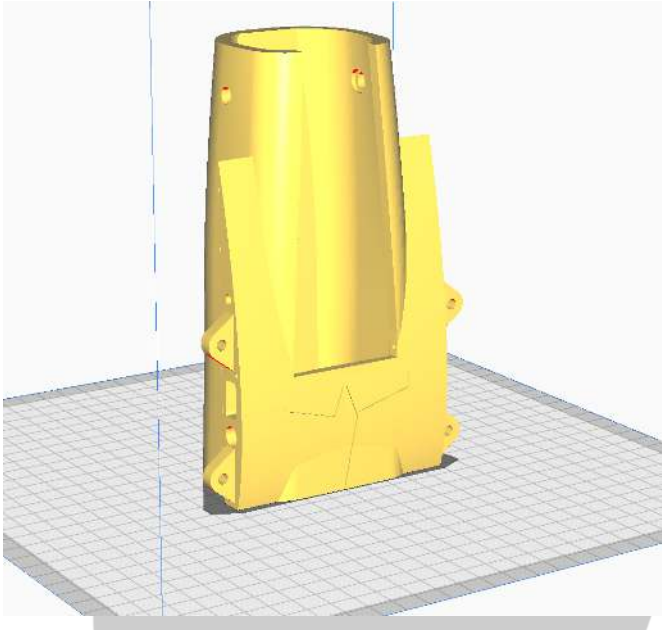

Fuse2

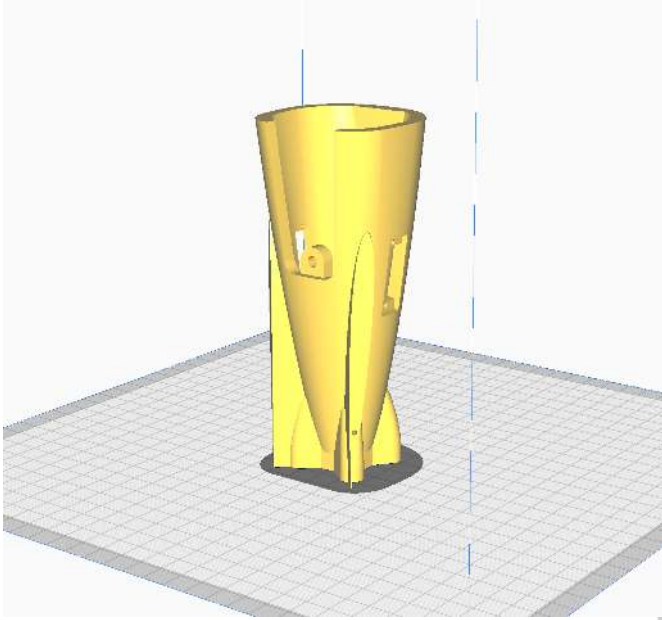

Fuse3

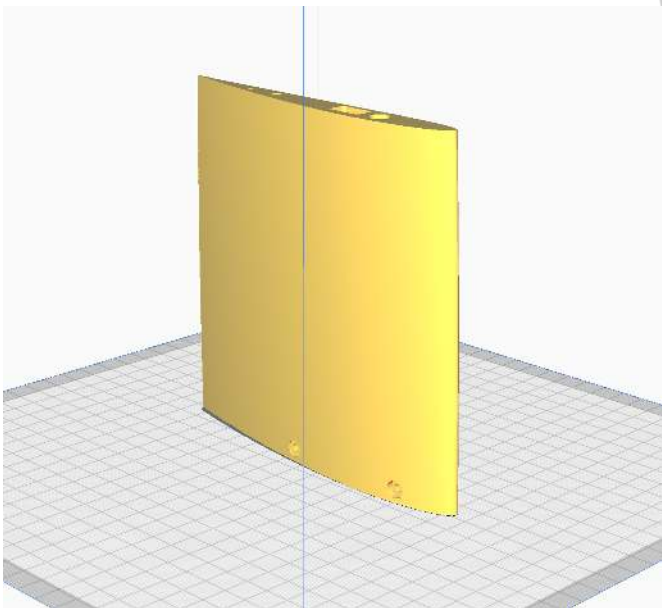

Wing1

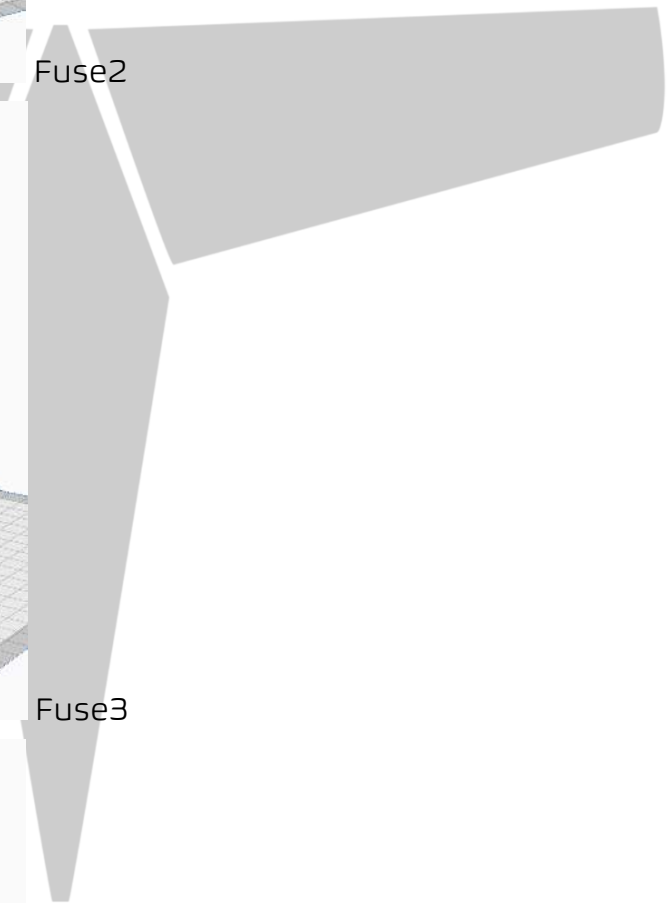





Titan Dynamics

[Titan Dynamics Webpage](#)

[Visit our Facebook page](#)

[Join our Discord server](#)

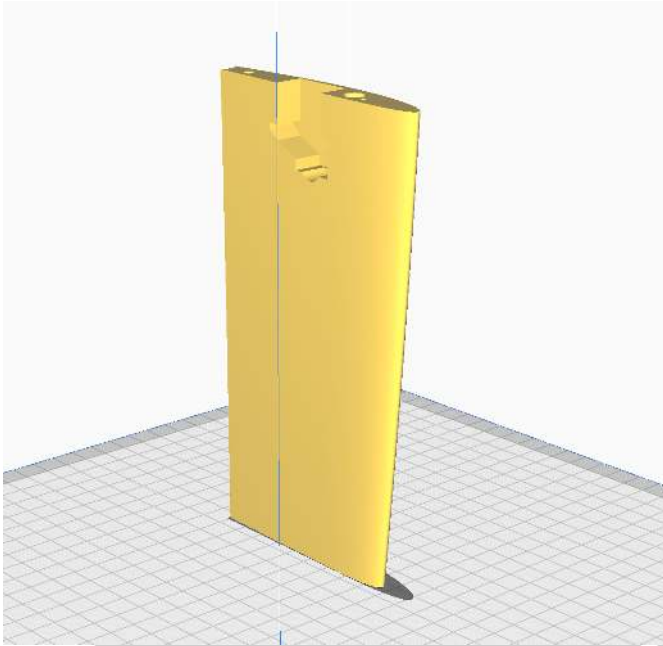

Wing2

### 4.3: Tuning “hole horizontal expansion”

It is very important to check the fitment of the carbon rods in their holes on the first parts you print. Because everyone may be using different printers, materials and slicer settings, it is not possible to provide the models with a slicing profile and hole size that will work for everyone.

Print your first part with carbon spar hole and check fitment, if it is too tight increase the hole horizontal expansion setting in the “walls” section in Cura (or your slicer’s similar setting). A good starting point is 0.25mm. If it is too loose, just decrease the setting until you can reliably push the rods in and still get a snug fit.

### 4.4: Bed Adhesion and warping

When printing tall parts like this model requires, having good print adhesion to the bed is a necessity. Ideally you will print each part without any extra aids, however this may not be possible for many, especially those printing without an enclosure for their printer. A full brim can be used but this will typically have mixed results. If it works for you, use a glue stick on the print surface to improve adhesion. Cura also has a plugin that can be used to help with bed adhesion and to avoid warping.

Cura Marketplace: TabAntiWarping Plugin.

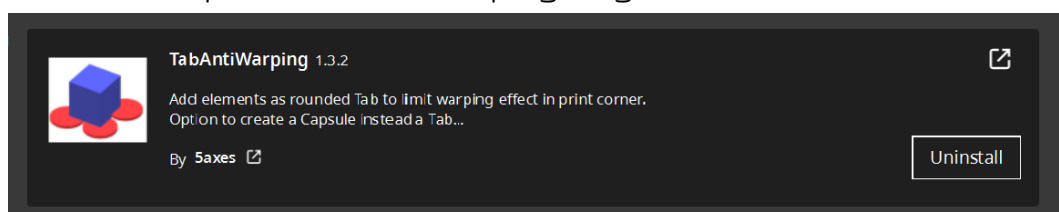



When installed, use the new icon at the bottom of the left menu to choose tab diameter and thickness, then click on the model to add a tab at each point you think is at risk of warping or poor adhesion (typically parts with low surface area in contact with the print surface in relation to their height). These new tabs can now be moved around to fine tune their position using the normal move controls on Cura.

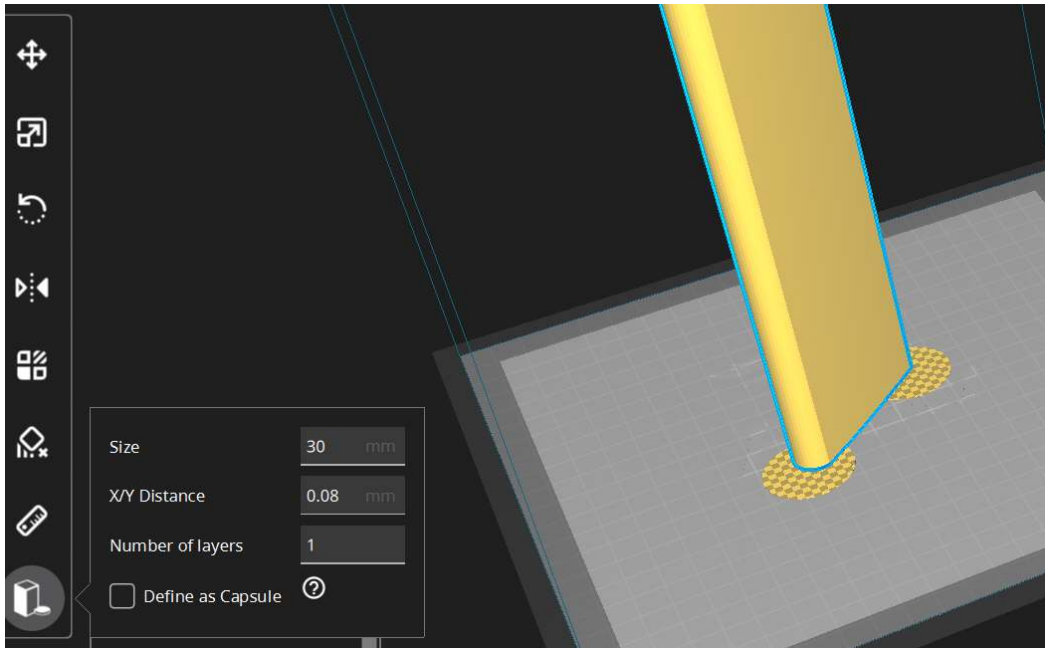

Once completed, be careful when removing these tabs from the print as they are quite strong and can damage the bottom of your part if not removed carefully. Re-open any holes the tab may have filled on the bottom of the print.

If you find these hard to remove from the print bed, select the “Define as Capsule” option. This makes the edge of the tabs raised, so you can get a scraper underneath them.



## Section 5: Assembly of 3D Printed Parts

Below are a few exploded views of the Micro Talon to help with assembly.

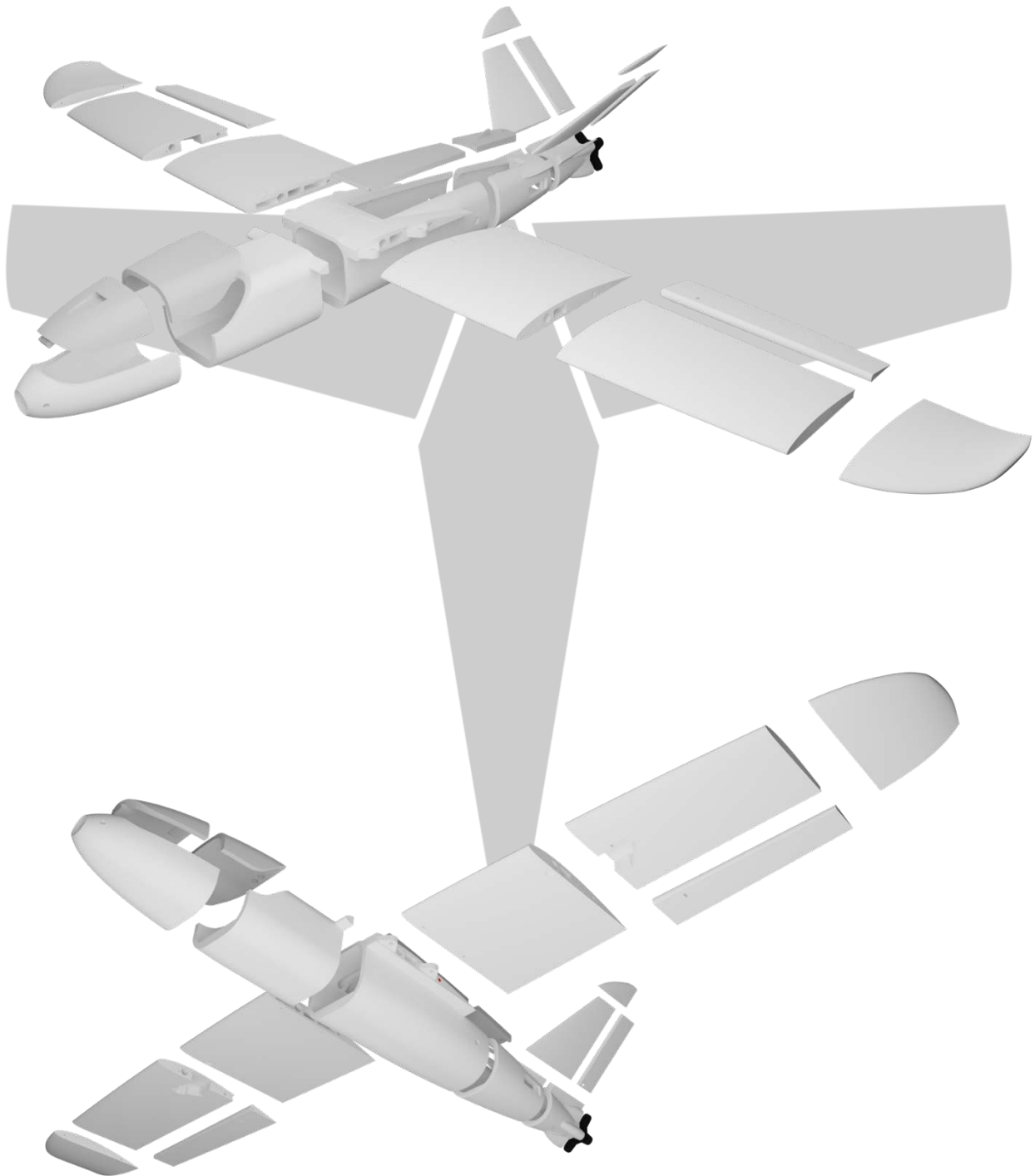



Titan Dynamics

[Titan Dynamics Webpage](#)

[Visit our Facebook page](#)

[Join our Discord server](#)

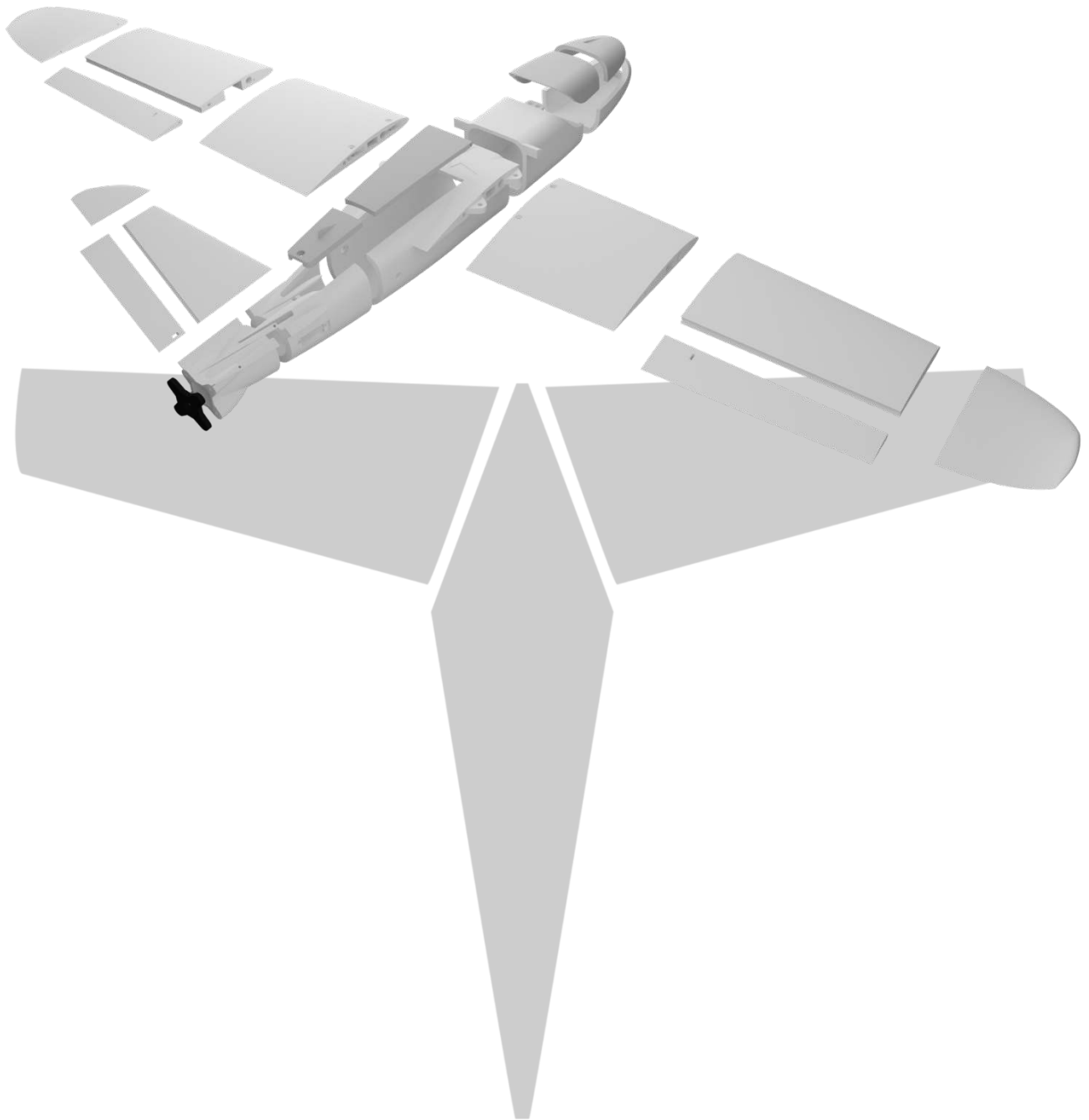



The spar layout for Micro Talon is as depicted below. None of the spars need to be glued in, they will all be retained by the printed parts. The two wing spars that intersect the fuselage are the joiners for the wings and the fuselage and can be removed completely from the fuselage and wing during transport.

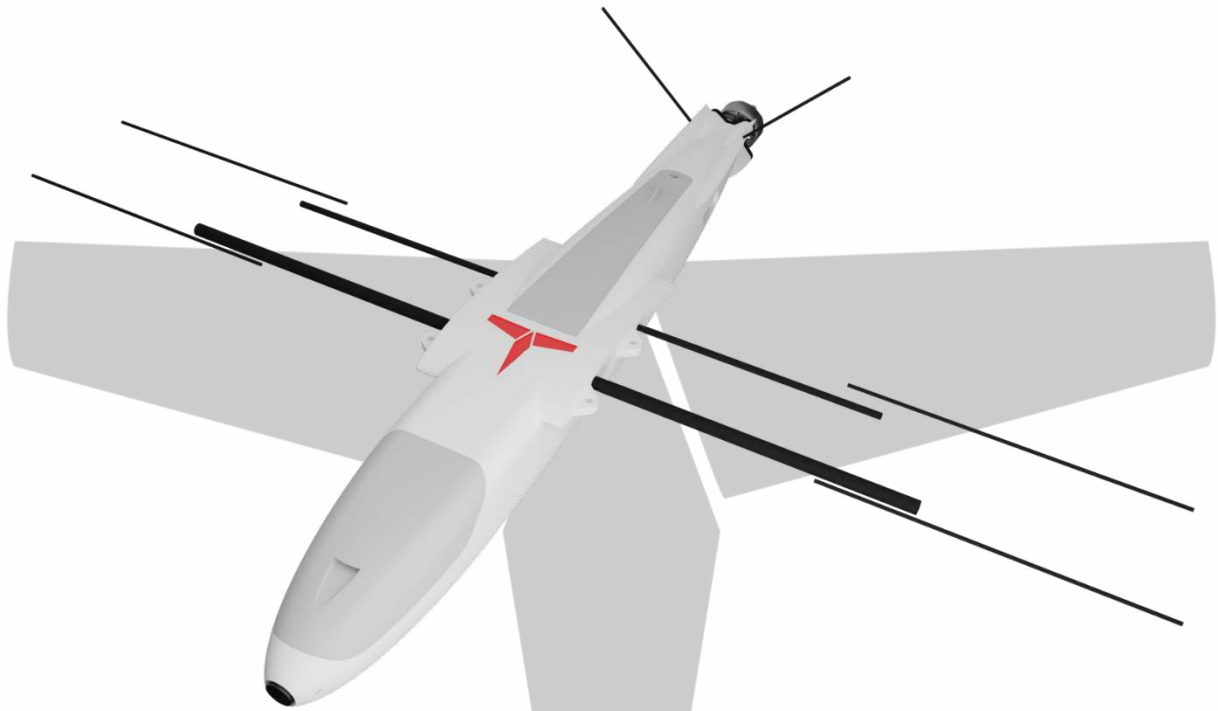

- ❑ Medium CA glue should be used to assemble all fuselage parts
- ❑ When first putting the glued parts together be sure to wipe any excess glue off before it sets. A kicker may then be used to speed up the setting time; technically this results in a weaker joint, however it will still be stronger than the base material LW-PLA.
- ❑ Use care when aligning parts for gluing. With medium CA, you should have a few seconds to get alignment right. Small mistakes in alignment can stack up and eventually lead to a part not fitting perfectly. We have taken care when designing the aircraft to make sure there is tolerance for some minor mistakes, but try to be as perfect as possible when gluing.
- ❑ When gluing the wings together, use the carbon rods to ensure alignment however be careful not to glue them in, they should not be glued in on the final product.
- ❑ **IMPORTANT!** - Do not glue the wing tips on until you have the carbon rod and aileron/flap installed as it's the wing tip that secures these in place. If you glue the wing tip on before inserting the control surfaces + carbon rod you will not be able to insert them afterwards.
- ❑ Threaded inserts can be properly installed by using a soldering iron at low heat setting, a good guide for doing this can be found at [this link](#).



## Section 6: Final Setup & Tuning Tips

- Titan Dynamics strongly recommends the use of Arduplane for all our models.
- Give all control surfaces +- 35 degrees or more throw.
- Setup motor rotation such that props rotate inwards towards the fuselage for added torque roll during differential yaw.
- Take-off does not require flaps, but landing can be done easier with half flaps.
- CG is marked under the wing, and should be kept very close to that point.
- Add duct tape or other abrasion resistant material to bottom of the fuselage to increase durability if landing on rough surfaces.

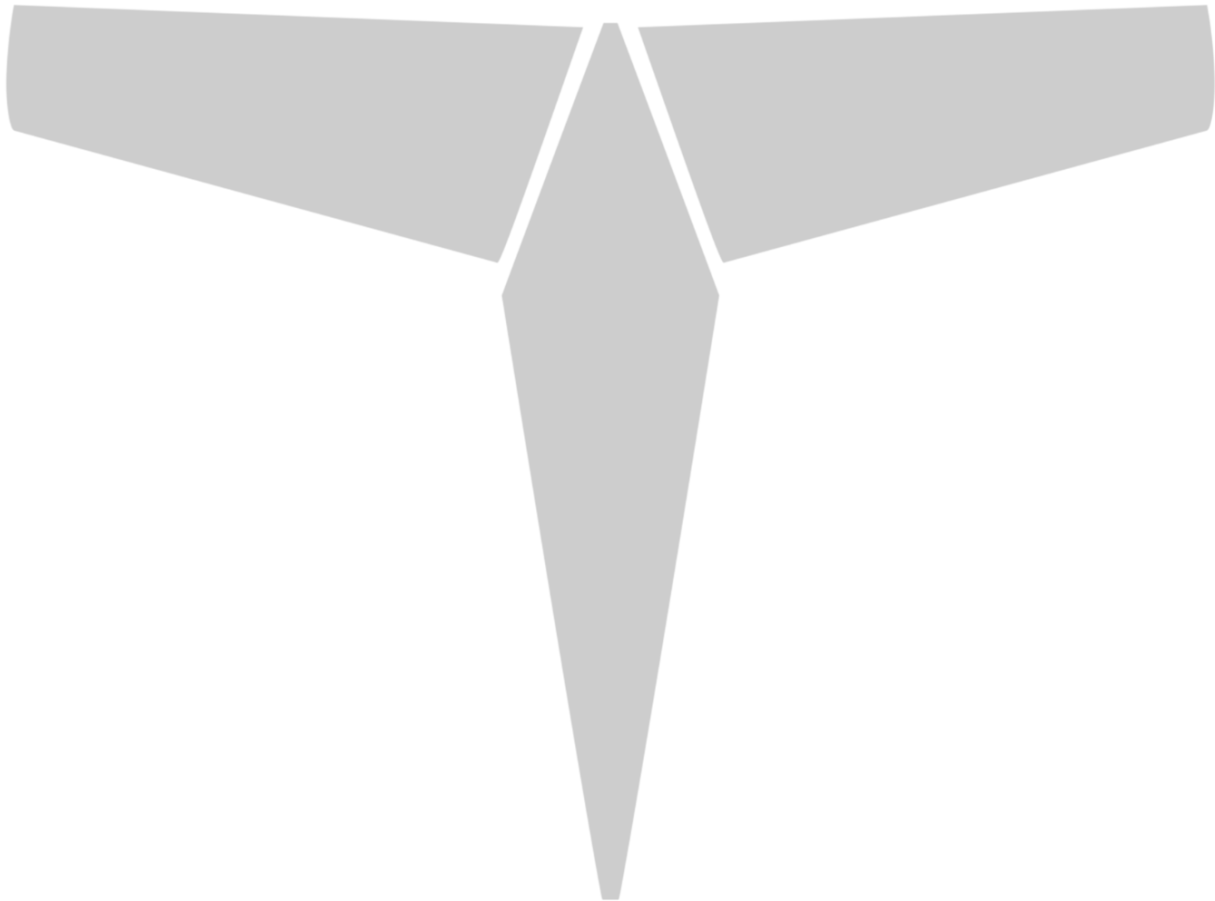



## Section 7: Additional Images

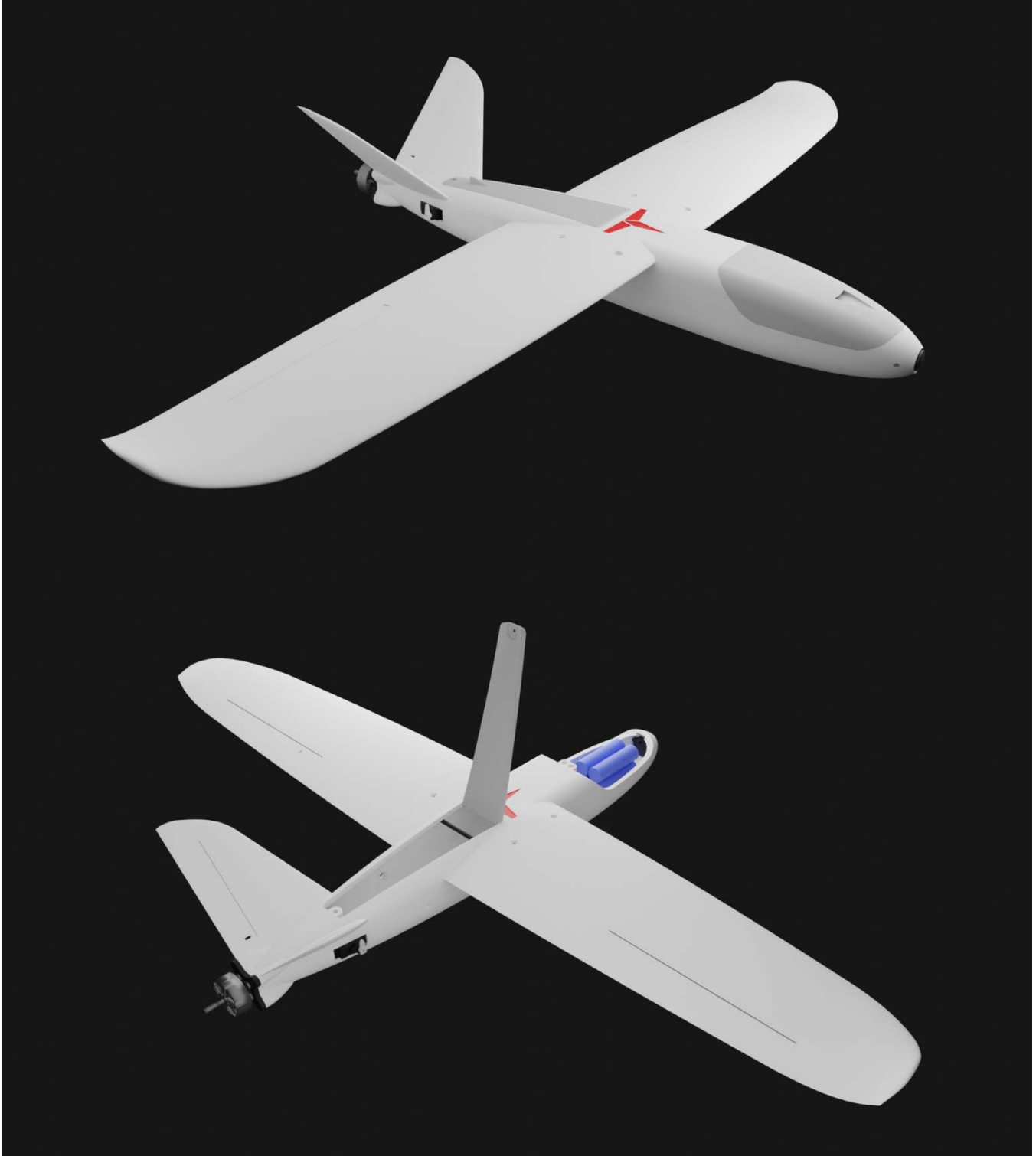



Titan Dynamics

[Titan Dynamics Webpage](#)

[Visit our Facebook page](#)

[Join our Discord server](#)

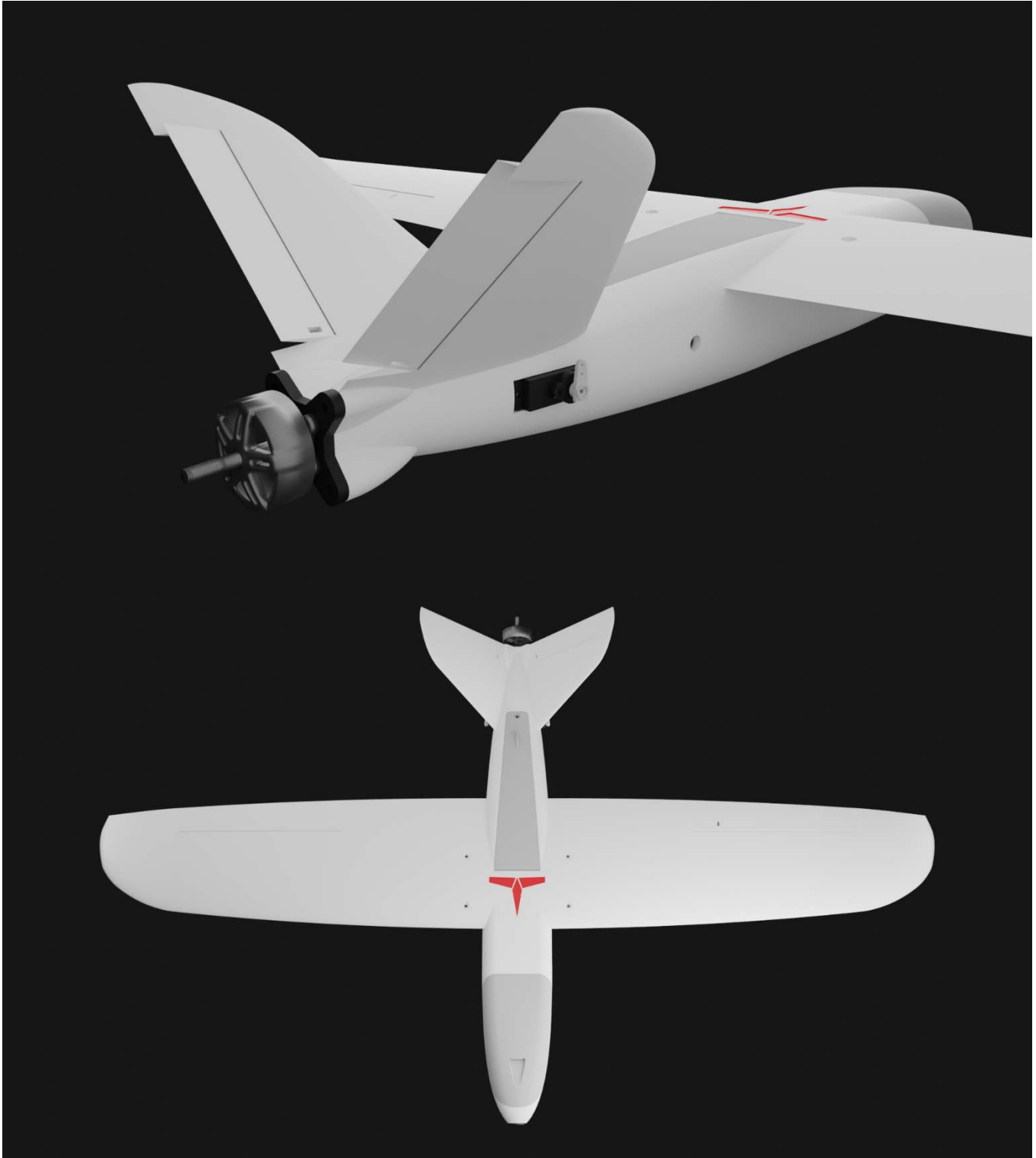





Titan Dynamics

[Titan Dynamics Webpage](#)

[Visit our Facebook page](#)

[Join our Discord server](#)

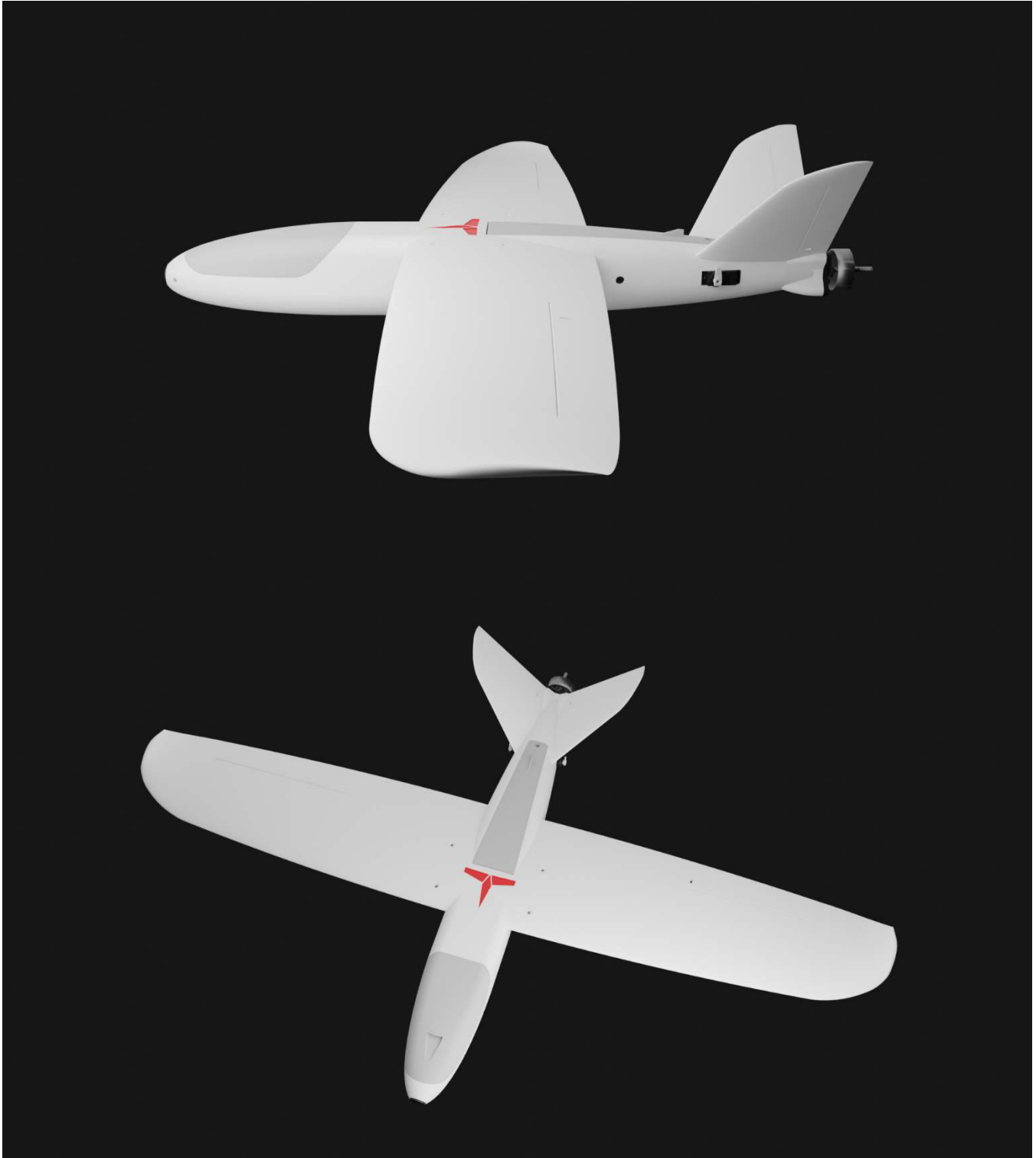



Titan Dynamics

[Titan Dynamics Webpage](#)

[Visit our Facebook page](#)

[Join our Discord server](#)

