

UMX™ Air Tractor

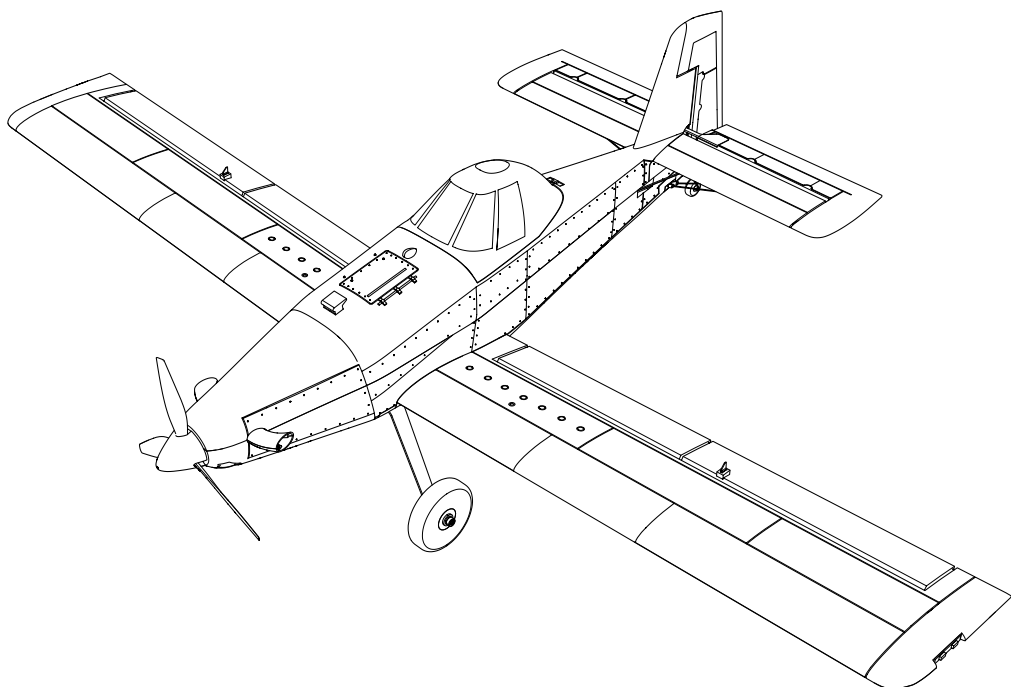

Scan the QR code and select the Manuals and Support quick links from the product page for the most up-to-date manual information.

Scannen Sie den QR-Code und wählen Sie auf der Produktseite die Quicklinks Handbücher und Unterstützung, um die aktuellsten Informationen zu Handbüchern.

Scannez le code QR et sélectionnez les liens rapides Manuals and Support sur la page du produit pour obtenir les informations les plus récentes sur le manuel.

Scannerizzare il codice QR e selezionare i Link veloci Manuali e Supporto dalla pagina del prodotto per le informazioni manuali più aggiornate.



EFLU16450

Instruction Manual
Bedienungsanleitung
Manuel d'utilisation
Manuale di Istruzioni

NOTICE

All instructions, warranties and other collateral documents are subject to change at the sole discretion of Horizon Hobby, LLC. For up-to-date product literature, visit horizonhobby.com or towerhobbies.com and click on the support or resources tab for this product.

MEANING OF SPECIAL LANGUAGE

The following terms are used throughout the product literature to indicate various levels of potential harm when operating this product:

WARNING: Procedures, which if not properly followed, create the probability of property damage, collateral damage, and serious injury OR create a high probability of superficial injury.

CAUTION: Procedures, which if not properly followed, create the probability of physical property damage AND a possibility of serious injury.

NOTICE: Procedures, which if not properly followed, create a possibility of physical property damage AND little or no possibility of injury.



WARNING: Read the ENTIRE instruction manual to become familiar with the features of the product before operating. Failure to operate the product correctly can result in damage to the product, personal property and cause serious injury.

This is a sophisticated hobby product. It must be operated with caution and common sense and requires some basic mechanical ability. Failure to operate this Product in a safe and responsible manner could result in injury or damage to the product or other property. This product is not intended for use by children without direct adult supervision. Do not use with incompatible components or alter this product in any way outside of the instructions provided by Horizon Hobby, LLC. This manual contains instructions for safety, operation and maintenance. It is essential to read and follow all the instructions and warnings in the manual, prior to assembly, setup or use, in order to operate correctly and avoid damage or serious injury.

Age Recommendation: Not for children under 14 years. This is not a toy.

Safety Precautions and Warnings

As the user of this product, you are solely responsible for operating in a manner that does not endanger yourself and others or result in damage to the product or the property of others.

- Always keep a safe distance in all directions around your model to avoid collisions or injury. This model is controlled by a radio signal subject to interference from many sources outside your control. Interference can cause momentary loss of control.
- Always operate your model in open spaces away from full-size vehicles, traffic and people.
- Always carefully follow the directions and warnings for this and any optional support equipment (chargers, rechargeable battery packs, etc.).
- Always keep all chemicals, small parts and anything electrical out of the reach of children.
- Always avoid water exposure to all equipment not specifically designed and protected for this purpose. Moisture causes damage to electronics.
- Never place any portion of the model in your mouth as it could cause serious injury or even death.
- Never operate your model with low transmitter batteries.
- Always keep aircraft in sight and under control.
- Always use fully charged batteries.
- Always keep transmitter powered on while aircraft is powered.
- Always remove batteries before disassembly.
- Always keep moving parts clean.
- Always keep parts dry.
- Always let parts cool after use before touching.
- Always remove batteries after use.
- Always ensure failsafe is properly set before flying.
- Never operate aircraft with damaged wiring.
- Never touch moving parts.



WARNING AGAINST COUNTERFEIT PRODUCTS: If you ever need to replace your Spektrum receiver found in a Horizon Hobby product, always purchase from Horizon Hobby, LLC or a Horizon Hobby authorized dealer to ensure authentic high-quality Spektrum product. Horizon Hobby, LLC disclaims all support and warranty with regards, but not limited to, compatibility and performance of counterfeit products or products claiming compatibility with DSM or Spektrum technology.

Registration

Register your product today to join our mailing list and keep up to date with product updates, offers and E-flite® news.



Table of Contents

General Binding Tips and Failsafe	3
Low Voltage Cutoff (LVC)	4
Transmitter Setup	4–5
Transmitter and Receiver Binding.....	6
Smart Technology Telemetry	6
SAFE® Select Technology.....	6
Differences Between SAFE and AS3X Modes.....	7
Disabling and Enabling SAFE Select.....	7
DXe and DXS Transmitters	7
ESC/Receiver Arming and Battery Installation.....	8
Center of Gravity (CG)	8
Control Direction Test.....	9
Control Centering.....	10
Hand Launching.....	10
Post Flight Checklist	10
Service and Repairs.....	11
Disassembly	11
Assembly.....	11
Pushrod Factory Positions.....	11
AS3X® System Trouble Shooting Guide.....	12
Troubleshooting Guide	12–13
Replacement Parts.....	14
Recommended Parts.....	14
Optional Parts and Accessories	14
Important Federal Aviation Administration (FAA) Information	15
AMA National Model Aircraft Safety Code	15
Limited Warranty	16
Contact Information	17
FCC Information	17
IC Information	17
Compliance Information for the European Union.....	17

General Binding Tips and Failsafe

- The included receiver has been specifically programmed for operation of this aircraft. Refer to the receiver manual for correct setup if the receiver is replaced.
- Keep away from large metal objects while binding.
- Do not point the transmitter's antenna directly at the receiver while binding.
- The red LED on the receiver will flash rapidly when the receiver enters bind mode.
- Once bound, the receiver will retain its bind settings for that transmitter until you re-bind.
- If the receiver loses transmitter communication, the failsafe will activate. Failsafe moves the throttle channel to low throttle. Pitch and roll channels move to actively stabilize the aircraft in a descending turn.
- If problems occur, refer to the troubleshooting guide or if needed, contact the appropriate Horizon Product Support office.

Specifications

Wingspan	27.6" (702mm)
Length	17.8" (451mm)
Weight	Without Battery: 4.9 oz (138g) With Recommended 3S 300mAh Battery: 6 oz (169g)

Included Equipment

Receiver/ESC	Spektrum™ AS3X/SAFE Receiver (SPMA3193)
Motor	1208–2150Kv Brushless Outrunner Motor, 12-Pole (SPMXAM1208B)
Servos	Aileron: (2) 2.3g Long-Throw Offset Servo (SPMSA2030L0) Flap: (1) 2.9g Linear Servo (SPMSH2040T)

Recommended Equipment

Transmitter	DX6e DXS 2.4GHz (SPMR1010)
Flight Battery	Spektrum 3S 300mAh, 30C (SPMX3003SJ30)
Battery Charger	3S LiPo Battery Compatible

Optional Batteries

SPMX3002S30	7.4V 300mAh 2S 30C LiPo Battery: PH
SPMXCA327	Adapter: JST-RCY Battery / JST-PH Device

Low Voltage Cutoff (LVC)

When a Li-Po battery is discharged below 3V per cell, it will not hold a charge. The aircraft's ESC protects the flight battery from over-discharge using Low Voltage Cutoff (LVC). Once the battery discharges to 3V per cell, the LVC will reduce the power to the motor in order to leave adequate power to the receiver and servos to land the airplane.

When the motor power decreases, land the aircraft immediately and replace or recharge the flight battery. Always disconnect and remove the Li-Po battery from

the aircraft after each flight. Charge your Li-Po battery to about half capacity before storage. Make sure the battery charge does not fall below 3V per cell. Failure to unplug a connected battery will result in trickle discharge.

For your first flights, set your transmitter timer or a stopwatch to 5 minutes. Adjust your timer for longer or shorter flights once you have flown the model.

NOTICE: Repeated flying to LVC will damage the battery.

Transmitter Setup

If your transmitter allows it, enable the throttle cut feature. Always engage throttle cut before approaching the aircraft.

Dual Rates

Low rate is recommended for the initial flights.

NOTICE: To ensure AS3X® technology functions properly, do not lower rate values below 50%.

NOTICE: If oscillation occurs at high speed, refer to the Troubleshooting Guide for more information.

Exponential

After your initial flights, you may adjust the exponential value to better suit your flying style.

Telemetry Alarms

Rx V : Min Rx V	4.2V
Smart ESC : Low Voltage Alarm	3.4V
Smart Battery : Startup Volt Minimum	4.0V

NX Series Transmitter Setup

1. Power ON your transmitter, click on scroll wheel, roll to **System Setup** and click the scroll wheel. Select **YES**.
2. Go to **Model Select** and choose **Add New Model** near the bottom of the list. Select **Airplane Model Type** by choosing airplane image, select **Create**.
3. Set **Model Name**: Input a name for your model file.
4. Go to **Aircraft Type** and scroll to the wing selection, choose **Wing: 1 Ail 1 Flap Tail: Normal**
5. Select **Main Screen**, Click the scroll wheel to enter the **Function List**.
6. Go to **D/R (Dual Rate) and Expo** menu to set **D/R** and **Expo**.
7. Set **Rates and Expo: Aileron**
Set **Switch: Switch F**
Set **High Rates: 100%, Expo 10% — Low Rates: 70%, Expo 5%**
8. Set **Rates and Expo: Elevator**
Set **Switch: Switch C**
High Rates: 100%, Expo 10% — Low Rates 70%, Expo 5%
9. Set **Throttle Cut; Switch: Switch H, Position: -100%**
10. Select **Flap System**
Set **Switch: Switch D**
Set **Flaps: POS 0: -100%, POS 1: 0%, POS 2: 100%**
Set **ELEV: POS 0: 0%, POS 1: 7%, POS 2: 15%**
Set **Speed: 2.0 s**

Transmitter Setup

DX Series Transmitter Setup

1. Power ON your transmitter, click on scroll wheel, roll to **System Setup** and click the scroll wheel. Select **YES**.
2. Go to **Model Select** and choose **Add New Model** at the bottom of the list. The system asks if you want to create a new model, select **Create**.
3. Set **Model Type**: Select **Airplane Model Type** by choosing the airplane. The system asks you to confirm model type, data will be reset. Select **YES**.
4. Set **Model Name**: Input a name for your model file.
5. Go to **Aircraft Type** and scroll to the wing selection, choose **Wing: 1 Ail 1 Flap Tail: Normal**
6. Select **Main Screen**, Click the scroll wheel to enter the **Function List**.
7. Set **D/R (Dual Rate) and Expo: Aileron**
Set Switch: **Switch F**
Set High Rates: **100%, Expo 10%** — Low Rates: **70%, Expo 5%**
8. Set **D/R (Dual Rate) and Expo: Elevator**
Set Switch: **Switch C**
High Rates: **100%, Expo 10%** — Low Rates **70%, Expo 5%**
9. Set **Throttle Cut; Switch: Switch H, Position: -100%**
10. Select **Flaps**
Set Switch: **SWITCH D**
Set Flaps: **POS 0: -100%, POS 1: 0%, POS 2: 100%**
Set **ELEV: POS 0: 0%, POS 1: 7%, POS 2: 15%**
Set **Speed: 2.0 s**

iX Series Transmitter Setup

1. Power ON your transmitter and begin once the Spektrum AirWare app is open. Select the orange pen icon in the screen's upper left corner, the system asks for permission to **Turn Off RF**, select **PROCEED**.
2. Select the three dots in the upper right corner of the screen, select **Add a New Model**.
3. Select **Model Option**, choose **DEFAULT**, select **Airplane**. The system asks if you want to create a new acro model, select **Create**.
4. Select the last model on the list, named **Acro**. Tap on the word Acro and rename the file to a name of your choice.
5. Press and hold the back arrow icon in the upper left corner of the screen to return to the main screen.
6. Go to the **Model Setup** menu. Select **Aircraft Type**. The system asks for permission to **Turn Off RF**, select **PROCEED**. Touch the screen to select wing. Select **1 Ail 1 Flap**.
7. Press and hold the back arrow icon in the upper left corner of the screen to return to the main screen.
8. Go to the **Model Adjust** menu.
9. Set **Dual Rates and Expo: Select Aileron**
Set Switch: **Switch F**
Set High Rates: **100%, Expo 10%** — Low Rates: **70%, Expo 5%**
10. Set **Dual Rates and Expo: Select Elevator**
Set Switch: **Switch C**
High Rates: **100%, Expo 10%** — Low Rates **70%, Expo 5%**
11. Select **Flap System**
Set Switch: **Switch D**
Set Flaps: **POS 0: -100%, POS 1: 0%, POS 2: 100%**
Set **ELEV: POS 0: 0%, POS 1: 7%, POS 2: 15%**
Set **Speed: 2.0 s**
12. Set **Throttle Cut; Switch: Switch H, Position: -100%**

Transmitter and Receiver Binding

Binding is the process of programming the receiver to recognize the GUID (Globally Unique Identifier) code of a single specific transmitter. You need to 'bind' your chosen Spektrum™ DSM2/DSMX technology equipped aircraft transmitter to the receiver for proper operation.

Any full range Spektrum DSM2/DSMX transmitter can bind to the DSM2/DSMX receiver.

✓	Binding Procedure
	1. Refer to your transmitter's unique instructions for binding to a receiver (location of transmitter's Bind control).
	2. Make sure the flight battery is disconnected from the aircraft.
	3. Power off your transmitter.
	4. Place the aircraft on a level surface away from wind.
	5. Connect the flight battery in the aircraft. The receiver LED will begin to flash rapidly (typically after 5 seconds).
	6. Make sure the transmitter controls are neutral and the throttle and throttle trim are in low position.
	7. Put your transmitter into bind mode. Refer to your transmitter's manual for binding button or switch instructions.
	8. After 5 to 10 seconds, the receiver status LED will turn solid, indicating that the receiver is bound to the transmitter. If the LED does not turn solid, refer to the Troubleshooting Guide at the back of the manual.

For subsequent flights, power ON the transmitter for 5 seconds before connecting the flight battery.

Smart Technology Telemetry

This aircraft includes Spektrum Smart Technology in the receiver, which can provide telemetry information like battery voltage. To take advantage of Smart Technology, you will need a compatible transmitter. A firmware update for your transmitter may be required.

To View Smart Telemetry

1. Begin with the transmitter bound to the receiver
2. Power on the transmitter.
3. Power on the aircraft.

4. The Smart Logo appears under the battery logo on the home page. A signal bar appears in the top left corner of the screen.

5. Scroll past the servo monitor to view Smart technology screens.

For more information about compatible transmitters, firmware updates, and how to use the Smart Technology on your transmitter, visit www.SpektrumRC.com.

SAFE® Select Technology

The UMX Air Tractor has two flight modes controlled by Channel 5, SAFE and AS3X. Switch A is the Spektrum default for channel 5. Position 0 is SAFE, Position 1 is AS3X only.

When flying in SAFE mode, the aircraft will return to level flight any time the aileron and elevator controls are at neutral. Applying aileron or elevator control will cause the airplane to bank, climb or dive. The amount the stick is moved will determine the attitude the airplane flies. Holding full control will push the aircraft to the pre-determined bank and pitch limits, but it will not go past those angles.

When flying in SAFE mode, it is normal to hold the control stick deflected with moderate aileron input when flying through a turn. To fly smoothly with SAFE, avoid making frequent control changes and don't attempt to correct for minor deviations. Holding deliberate control inputs will command the aircraft to fly at a specific angle, and the model will make all corrections to maintain that flight attitude.

Return the elevator and aileron controls to neutral before switching from SAFE mode to AS3X mode. If you do not neutralize controls when switching into AS3X mode, the control inputs used for SAFE mode will be excessive for AS3X mode and the aircraft will react immediately.

Differences Between SAFE and AS3X Modes

This section is generally accurate but does not take into account flight speed, battery charge status, and other limiting factors.

		SAFE Select	AS3X
Control Input	Control stick is neutralized	Aircraft will self level	Aircraft will continue to fly at its present attitude
	Holding a small amount of control	Aircraft will bank or pitch to a moderate angle and maintain the attitude	Aircraft will continue to pitch or roll slowly
	Holding full control	Aircraft will bank or pitch to the predetermined limits and maintain the attitude	Aircraft will continue to roll or pitch rapidly

Disabling and Enabling SAFE Select

By default, the SAFE Select function of your UMX aircraft is enabled and assigned to the gear channel switch (channel 5). If you do not wish to have access to SAFE Select while flying, you can choose to disable SAFE Select functionality. AS3X will still be active when SAFE Select is disabled.

IMPORTANT: Before attempting to disable or enable SAFE Select, ensure the aileron, elevator, rudder, throttle and gear channels are all on high rate with the travel set to 100%. Turn throttle hold OFF if it is programmed in the transmitter.



CAUTION: Keep all body parts clear of the propeller, and keep the aircraft securely restrained in case of accidental throttle activation.

1. Power on the transmitter.
2. Power on the aircraft.
3. Hold both transmitter sticks to the inside bottom corners and toggle the Gear switch 5 times (1 toggle = full up and down). The control surfaces of the aircraft will move, indicating SAFE Select has been enabled or disabled.

Repeat the process to disable or enable or disable SAFE Select. The aircraft will cycle both ailerons up and down to indicate a change has been made.

DXe and DXS Transmitters

Switch A is the FMODE switch on these transmitters, and the switch needs to be toggled between position 0 and 2 when disabling/enabling SAFE Select.

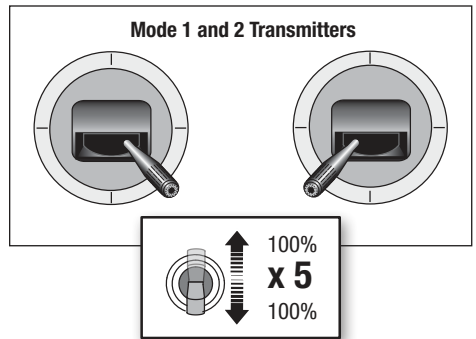

ESC/Receiver Arming and Battery Installation

CAUTION: Always keep hands away from the propeller. When armed, the motor will turn the propeller in response to any throttle movement.

Arming the ESC/receiver also occurs after binding as previously described, but subsequent connection of a flight battery requires the following steps.

AS3X

The AS3X® system will not **activate** until the throttle stick or trim is increased above 25% for the first time. Once active, the control surfaces may move rapidly and noisily on the aircraft. This is normal. AS3X technology will remain active until the battery is disconnected.

1. Open the battery hatch by lifting from the **front**.
2. Attach the battery to the hook and loop strip so the battery is centered in the battery cavity.
3. Lower the throttle and power on your transmitter. Enable throttle cut switch.
4. Connect the battery to the ESC, noting proper polarity. Keep the plane immobile and away from wind for 5 seconds to allow the AS3X system to initialize. A series of tones and a continuous LED (LED may be difficult to see as it is located inside of aircraft.) indicates a successful connection. A solid blue LED indicates that the aircraft is in SAFE flight mode, and a solid RED LED indicates that the aircraft is in AS3X flight mode. When the aircraft is in SAFE the servos will move without increasing throttle above 25%.

CAUTION: Always disconnect the Li-Po battery from the ESC when not flying to eliminate power supplied to the motor. The ESC does not have an arming switch and will respond to any transmitter input when a signal is present.

CAUTION: Always disconnect the Li-Po battery from the ESC when not flying to avoid over-discharging the battery. Batteries discharged to a voltage lower than the lowest approved voltage may become damaged, resulting in loss of performance and potential fire when batteries are charged.

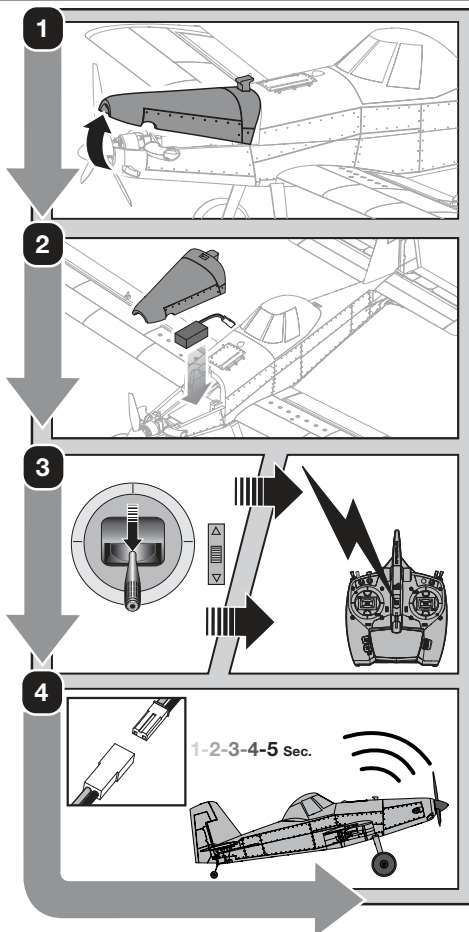

Center of Gravity (CG)

The CG location is 29mm \pm 2mm behind the leading edge of the wing. This CG location has been determined with the recommended battery. Check the CG with the model inverted. Adjust the battery forward or aft so the model balances level at the recommended point.

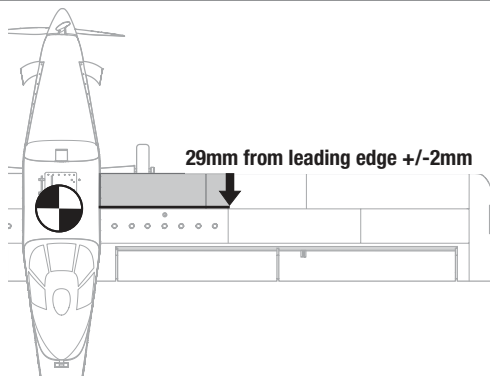

Control Direction Test



WARNING: Do not perform this or any other equipment test without turning on throttle cut. Serious injury or property damage could result from the motor starting inadvertently.

If the control surfaces do not respond as shown, **DO NOT FLY.** Refer to the *Troubleshooting Guide* for more information. If you need more assistance, contact the appropriate Horizon Hobby Product Support department.

1. Power on the transmitter.
2. Enable the throttle cut.
3. Connect the battery.
4. Use the transmitter to operate the aileron, elevator and rudder controls.

NOTICE: View the aircraft from the rear when checking the control directions.

Elevators

1. Pull the elevator stick back. The elevator should move up, which will cause the aircraft to pitch up.
2. Push the elevator stick forward. The elevator should move down, which will cause the aircraft to pitch down.

Ailerons

1. Move the aileron stick to the left. The left aileron should move up and the right aileron down, which will cause the aircraft to bank left.
2. Move the aileron stick to the right. The right aileron should move up and the left aileron down, which will cause the aircraft to bank right.

Rudder

1. Move the rudder stick to the left. The rudder should move to the left, which will cause the aircraft to yaw left.
2. Move the rudder stick to the right. The rudder should move to the right, which will cause the aircraft to yaw right.

NOTE: The UMX Air Tractor uses offset servos for aileron control. It is normal to see the ailerons move up more than down during the control test. (For example, left control input, left aileron will move up more than the right aileron will move down.)

	Transmitter Command	Control Surface Response (viewed from the rear)
Elevator		
Aileron		
Rudder		

Control Centering

Before the first flights, or in the event of an accident, make sure the flight control surfaces are centered.

Adjust the linkages mechanically if the control surfaces are not centered. Use of the transmitter sub-trims may not correctly center the aircraft control surfaces due to the mechanical limits of linear servos.

1. Make sure the control surfaces are neutral when the transmitter controls and trims are centered. The transmitter sub-trim must always be set to zero.
2. When needed, use a pair of pliers to carefully bend the metal linkage.
3. Make the U-shape narrower to make the linkage shorter. Make the U-shape wider to make the linkage longer.

Centering Controls After First Flights

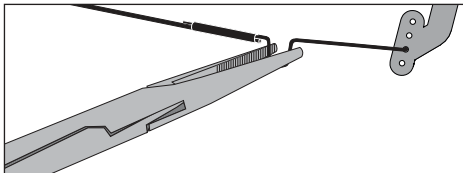

For best performance with AS3X, it is important that excessive trim is not used. If the aircraft requires excessive transmitter trim (4 or more clicks of trim per channel), return the transmitter trim to zero and adjust the linkages mechanically so that the control surfaces are in the flight trimmed position.

Hand Launching

NOTICE: Hand Launching in AS3X mode is not recommended as it may result in a crash. Always hand launch in SAFE Mode.

Always hand launch in SAFE mode, into the wind at 100% power, in high rates.

When hand launching in SAFE mode, the control unit will immediately sense the force of the launch and will automatically enable the Hand Launch Assist feature. When this feature is active, the control unit will add up elevator automatically so the aircraft climbs at a higher angle for a few seconds. It will return to standard SAFE mode shortly after launch.

Grip

We recommend holding the aircraft just behind the wings, as shown.

Follow Through

Use an overhand throw and launch with wings level and the nose of the model slightly upwards. Follow through with your hand launch by pointing your fingers at the airplane after the throw. Avoid an arcing throw which can pull the nose down at release.

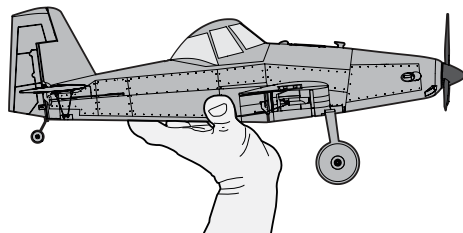

Post Flight Checklist

Disconnect the flight battery from the ESC. (Required for safety and battery life.)

Power OFF the transmitter.

Remove the flight battery from the aircraft.

Store the flight battery apart from the aircraft and monitor the battery charge.

Service and Repairs

Disassembly



CAUTION: DO NOT handle the propeller while the flight battery is connected to the ESC. Personal injury could result.

Propeller

1. Gently grasp the spinner (A) taking care not to crush it, and pull while rocking the spinner back and forth to break the adhesive.
The propeller and spinner are glued together, glue residue will need to be cleaned from the spinner or propeller when these parts are used again.
2. Carefully remove the 2 x 6mm self-tapping screw (B) using a Phillips #1 screwdriver.
3. Carefully remove the propeller (C) from the motor shaft.

Motor

1. Disconnect the motor wire connector from the ESC/receiver connector.
2. Remove the M2 x 10 machine screw (D) using a Phillips #1 screwdriver.
3. Remove the motor (E) from the motor mount.
4. Remove 3 M1.5 x 3 machine screws (F) using a Phillips #0 screwdriver.
5. Remove the propeller adapter (G) from the motor. The motor magnet may attract screws to the motor.

Assembly

Assemble in reverse order.

- Connect the motor wire connector to the ESC/receiver.
- The two dimples in the propeller hub must be facing forward for correct propeller operation.
- Attach the spinner to the propeller using DLMAD34 Deluxe Materials Foam 2 Foam adhesive.
- Ensure the propeller adapter and motor mount are fully connected to the motor.

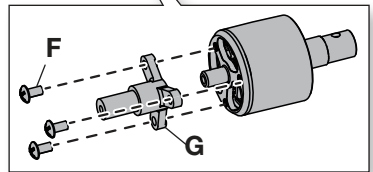
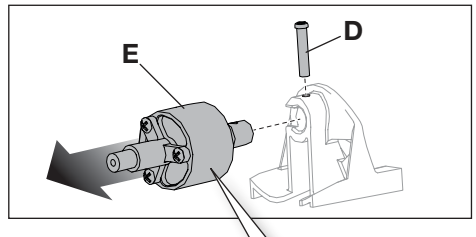
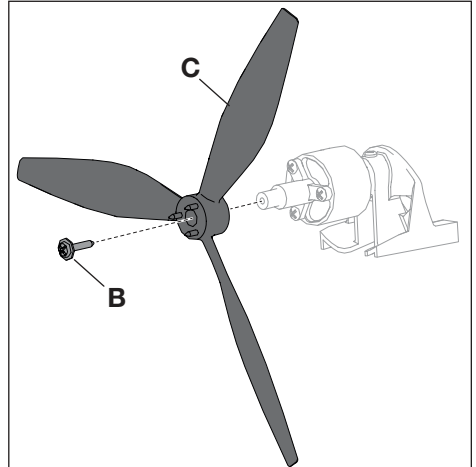
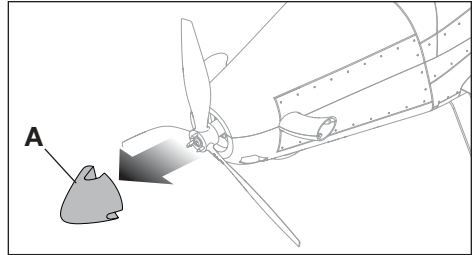

Pushrod Factory Positions

The illustration shows the factory settings for the control horns. Fly the aircraft at factory settings before making changes.

After flying, you may choose to adjust the linkage positions for the desired control response.



CAUTION: When these are incorrectly connected for the pilot's skill level, unexpected aircraft response to controls can result. This can cause damage to the aircraft and personal injury.

	Elevator	Ailerons	Rudder
Horns			

AS3X® System Trouble Shooting Guide

Problem	Possible Cause	Solution
Control surfaces not at neutral position when transmitter controls are at neutral	Control surfaces may not have been mechanically centered from factory	Center control surfaces mechanically by adjusting the U-bends on control linkages
	Aircraft was moved after the flight battery was connected and before sensors initialized	Disconnect and reconnect the flight battery while keeping the aircraft still for 5 seconds
Model flies inconsistently from flight to flight	Aircraft was not kept immobile for 5 seconds after battery was plugged in	Keep the aircraft immobile for 5 seconds after plugging in the battery
	Trims are moved too far from neutral position	Neutralize trims and mechanically adjust linkages to center control surfaces
Controls oscillate in flight, (model rapidly jumps or moves)	Propeller is unbalanced, causing excessive vibration	Remove propeller and rebalance or replace it if damaged
	Propeller screw is loose, causing vibration	Tighten the propeller screw

Troubleshooting Guide

Problem	Possible Cause	Solution
Aircraft will not respond to throttle but responds to other controls	Throttle stick and/or throttle trim too high	Reset controls with throttle stick and throttle trim at lowest setting
	Throttle channel is reversed	Reverse throttle channel on transmitter
	Motor disconnected from receiver	Open fuselage and make sure motor is connected to the receiver
Extra propeller noise or extra vibration	Damaged propeller, spinner or motor	Replace damaged parts
	Propeller screw is loose	Tighten the propeller screw
	Propeller is out of balance	Remove and balance propeller, or replace with a balanced propeller
Reduced flight time or aircraft underpowered	Flight battery charge is low	Completely recharge flight battery
	Propeller installed backwards	Install propeller with numbers facing forward
	Flight battery damaged	Replace flight battery and follow flight battery instructions
	Flight conditions may be too cold	Make sure battery is warm before use
	Battery capacity too low for flight conditions	Replace battery or use a larger capacity battery
LED on receiver flashes and aircraft will not bind to transmitter (during binding)	Transmitter too near aircraft during binding process	Power off transmitter, move transmitter a larger distance from aircraft, disconnect and reconnect flight battery to aircraft and follow binding instructions
	Bind switch or button not held long enough during bind process	Power off transmitter and repeat bind process. Hold transmitter bind button or switch until receiver is bound
	Aircraft or transmitter is too close to large metal object, wireless source or another transmitter	Move aircraft and transmitter to another location and attempt binding again

Troubleshooting Guide

Problem	Possible Cause	Solution
LED on receiver flashes rapidly and aircraft will not respond to transmitter (after binding)	Less than a 5-second wait between first powering on transmitter and connecting flight battery to aircraft	Leaving transmitter on, disconnect and reconnect flight battery to aircraft
	Aircraft bound to different model memory (ModelMatch™ radios only)	Select correct model memory on transmitter and disconnect and reconnect flight battery to aircraft
	Flight battery/transmitter battery charge is too low	Replace/recharge batteries
	Transmitter may have been bound to a different model (or with a different DSM Protocol)	Select the right transmitter or bind to the new one
	Aircraft or transmitter is too close to large metal object, wireless source or another transmitter	Move aircraft and transmitter to another location and attempt linking again
Control surface does not move	Control surface, control horn, linkage or servo damage	Replace or repair damaged parts and adjust controls
	Wire damaged or connections loose	Do a check of wires and connections, connect or replace as needed
	Flight battery charge is low	Fully recharge flight battery
	Control linkage does not move freely	Make sure control linkage moves freely
Controls reversed	Transmitter settings reversed	Adjust controls on transmitter appropriately
Motor loses power	Damage to motor or power components	Do a check of motor and power components for damage (replace as needed)
Motor power quickly decreases and increases then motor loses power	Battery power is down to the point of receiver/ESC Low Voltage Cutoff (LVC)	Recharge flight battery or replace battery that is no longer performing
Motor/ESC is not armed after landing	Over Current Protection (OCP) stops the motor when the transmitter throttle is set high and the propeller cannot turn	Fully lower throttle and throttle trim to arm ESC
Servo locks or freezes at full travel	Travel adjust value is set above 100%, overdriving the servo	Set Travel adjust to 100% or less and/or set sub-trims to Zero and adjust linkages mechanically

Replacement Parts

Part #	Description
EFLU1168	Prop Adapter (Long)
EFLU16451	Wing with Servos
EFLU16452	Tail Set
EFLU16453	Pushrod Set
EFLU16454	Fuselage
EFLU16455	Battery Hatch
EFLU16456	Spinner Set
EFLU16457	Landing Gear Set
EFLU16458	Decal Sheet
EFLU16459	Motor Mount
EFLUP120703B	120mm x 70mm 3-Blade Propeller
SPMA3193	Receiver/ESC
SPMSH2040T	2.9g Linear Servo
SPMSA2030LO	2.3g Long-Throw Offset Linear Servo
SPMXAM1208B	1208–2150Kv Brushless Outrunner Motor, 12-Pole

Recommended Parts

Part #	Description
SPMR6655	DX6e 6-Channel DSMX Transmitter Only
SPMX3003SJ30	3S 11.1V 300mAh 30C LiPo Battery: RCY
SPMXC2050	Smart S155 G2 AC 1x55W Charger
SPMXCA310	Adapter: IC3 Battery / JST-RCY Device

Optional Parts and Accessories

Part #	Description
EFLU1039	Hook and Loop Set (5)
SPMR6655	DX6e 6-Channel DSMX Transmitter Only
SPMR8200	NX8 8-Channel DSMX Transmitter Only
SPMX3002S30	7.4V 300mAh 2S 30C LiPo Battery: PH
SPMXCA326	Adapter: IC3 Battery/JST-PH Device
SPMXCA327	Adapter: JST Battery/JST PH2.0 3P

Important Federal Aviation Administration (FAA) Information

Use the QR code below to learn more about the **Recreational UAS Safety Test (TRUST)**, as was introduced by the 2018 FAA Reauthorization Bill. This free test is required by the FAA for all recreational flyers in the United States. The completed certificate must be presented upon request by any FAA or law enforcement official.



If your model aircraft weighs more than .55lbs or 250 grams, you are required by the FAA to register as a recreational flyer and apply your registration number to the outside of your aircraft. To learn more about registering with the FAA, use the QR code below.



AMA National Model Aircraft Safety Code

Effective January 1, 2018

A model aircraft is a non-human-carrying device capable of sustained flight within visual line of sight of the pilot or spotter(s). It may not exceed limitations of this code and is intended exclusively for sport, recreation, education and/or competition. All model flights must be conducted in accordance with this safety code and related AMA guidelines, any additional rules specific to the flying site, as well as all applicable laws and regulations.

As an AMA member I agree:

- I will not fly a model aircraft in a careless or reckless manner.
- I will not interfere with and will yield the right of way to all human-carrying aircraft using AMA's See and Avoid Guidance and a spotter when appropriate.
- I will not operate any model aircraft while I am under the influence of alcohol or any drug that could adversely affect my ability to safely control the model.
- I will avoid flying directly over unprotected people, moving vehicles, and occupied structures.
- I will fly Free Flight (FF) and Control Line (CL) models in compliance with AMA's safety programming.
- I will maintain visual contact of an RC model aircraft without enhancement other than corrective lenses prescribed to me. When using an advanced flight system, such as an autopilot, or flying First-Person View (FPV), I will comply with AMA's Advanced Flight System programming.
- I will only fly models weighing more than 55 pounds, including fuel, if certified through AMA's Large Model Airplane Program.
- I will only fly a turbine-powered model aircraft in compliance with AMA's Gas Turbine Program.
- I will not fly a powered model outdoors closer than 25 feet to any individual, except for myself or my helper(s) located at the flightline, unless I am taking off and landing, or as otherwise provided in AMA's Competition Regulation.
- I will use an established safety line to separate all model aircraft operations from spectators and bystanders.

Limited Warranty

What this Warranty Covers—Horizon Hobby, LLC, (Horizon) warrants to the original purchaser that the product purchased (the "Product") will be free from defects in materials and workmanship at the date of purchase.

What is Not Covered—This warranty is not transferable and does not cover (i) cosmetic damage, (ii) damage due to acts of God, accident, misuse, abuse, negligence, commercial use, or due to improper use, installation, operation or maintenance, (iii) modification of or to any part of the Product, (iv) attempted service by anyone other than a Horizon Hobby authorized service center, (v) Product not purchased from an authorized Horizon dealer, (vi) Product not compliant with applicable technical regulations, or (vii) use that violates any applicable laws, rules, or regulations.

OTHER THAN THE EXPRESS WARRANTY ABOVE, HORIZON MAKES NO OTHER WARRANTY OR REPRESENTATION, AND HEREBY DISCLAIMS ANY AND ALL IMPLIED WARRANTIES, INCLUDING, WITHOUT LIMITATION, THE IMPLIED WARRANTIES OF NON-INFRINGEMENT, MERCHANTABILITY AND FITNESS FOR A PARTICULAR PURPOSE. THE PURCHASER ACKNOWLEDGES THAT THEY ALONE HAVE DETERMINED THAT THE PRODUCT WILL SUITABLY MEET THE REQUIREMENTS OF THE PURCHASER'S INTENDED USE.

Purchaser's Remedy—Horizon's sole obligation and purchaser's sole and exclusive remedy shall be that Horizon will, at its option, either (i) service, or (ii) replace, any Product determined by Horizon to be defective. Horizon reserves the right to inspect any and all Product(s) involved in a warranty claim. Service or replacement decisions are at the sole discretion of Horizon. Proof of purchase is required for all warranty claims. SERVICE OR REPLACEMENT AS PROVIDED UNDER THIS WARRANTY IS THE PURCHASER'S SOLE AND EXCLUSIVE REMEDY.

Limitation of Liability—HORIZON SHALL NOT BE LIABLE FOR SPECIAL, INDIRECT, INCIDENTAL OR CONSEQUENTIAL DAMAGES, LOSS OF PROFITS OR PRODUCTION OR COMMERCIAL LOSS IN ANY WAY, REGARDLESS OF WHETHER SUCH CLAIM IS BASED IN CONTRACT, WARRANTY, TORT, NEGLIGENCE, STRICT LIABILITY OR ANY OTHER THEORY OF LIABILITY, EVEN IF HORIZON HAS BEEN ADVISED OF THE POSSIBILITY OF SUCH DAMAGES. Further, in no event shall the liability of Horizon exceed the individual price of the Product on which liability is asserted. As Horizon has no control over use, setup, final assembly, modification or misuse, no liability shall be assumed nor accepted for any resulting damage or injury. By the act of use, setup or assembly, the user accepts all resulting liability. If you as the purchaser or user are not prepared to accept the liability associated with the use of the Product, purchaser is advised to return the Product immediately in new and unused condition to the place of purchase.

Law—These terms are governed by Illinois law (without regard to conflict of law principals). This warranty gives you specific legal rights, and you may also have other rights which vary from state to state. Horizon reserves the right to change or modify this warranty at any time without notice.

WARRANTY SERVICES

Questions, Assistance, and Services—Your local hobby store and/or place of purchase cannot provide warranty support or service. Once assembly, setup or use of the Product has been started, you must contact your local distributor or Horizon directly. This will enable Horizon to better answer your questions and service you in the event that you may need any assistance.

For questions or assistance, please visit our website at www.horizonhobby.com, submit a Product Support Inquiry, or call the toll free telephone number referenced in the Warranty and Service Contact Information section to speak with a Product Support representative.

Inspection or Services—If this Product needs to be inspected or serviced and is compliant in the country you live and use the Product in, please use the Horizon Online Service Request submission process found on our website or call Horizon to obtain a Return Merchandise Authorization (RMA) number. Pack the Product securely using a shipping carton. Please note that original boxes may be included, but are not designed to withstand the rigors of shipping without additional protection. Ship via a carrier that provides tracking and insurance for lost or damaged parcels, as Horizon is not responsible for merchandise until it arrives and is accepted at our facility. An Online Service Request is available at http://www.horizonhobby.com/content/service-center_render-service-center. If you do not have internet access, please contact Horizon Product Support to obtain a RMA number along with instructions for submitting your product for service. When calling Horizon, you will be asked to provide your complete name, street address, email address and phone number where you can be reached during business hours. When sending product into Horizon, please include your RMA number, a list of the included items, and a brief summary of the problem. A copy of your original sales receipt must be included for warranty consideration. Be sure your name, address, and RMA number are clearly written on the outside of the shipping carton.

NOTICE: Do not ship LiPo batteries to Horizon. If you have any issue with a LiPo battery, please contact the appropriate Horizon Product Support office.

Warranty Requirements—For Warranty consideration, you must include your original sales receipt verifying the proof-of-purchase date. Provided warranty conditions have been met, your Product will be serviced or replaced free of charge. Service or replacement decisions are at the sole discretion of Horizon.

Non-Warranty Service—Should your service not be covered by warranty, service will be completed and payment will be required without notification or estimate of the expense unless the expense exceeds 50% of the retail purchase cost. By submitting the item for service you are agreeing to payment of the service without notification. Service estimates are available upon request. You must include this request with your item submitted for service. Non-warranty service estimates will be billed a minimum of ½ hour of labor. In addition you will be billed for return freight. Horizon accepts money orders and cashier's checks, as well as Visa, MasterCard, American Express, and Discover cards. By submitting any item to Horizon for service, you are agreeing to Horizon's Terms and Conditions found on our website http://www.horizonhobby.com/content/service-center_render-service-center.

ATTENTION: Horizon service is limited to Product compliant in the country of use and ownership. If received, a non-compliant Product will not be serviced. Further, the sender will be responsible for arranging return shipment of the un-serviced Product, through a carrier of the sender's choice and at the sender's expense. Horizon will hold non-compliant Product for a period of 60 days from notification, after which it will be discarded.

Contact Information

Country of Purchase	Horizon Hobby	Contact Information	Address
United States of America	Horizon Service Center (Repairs and Repair Requests)	servicecenter.horizonhobby.com/RequestForm/	2904 Research Rd Champaign, Illinois 61822 USA
	Horizon Product Support (Product Technical Assistance)	productsupport@horizonhobby.com 877-504-0233	
	Sales	websales@horizonhobby.com 800-338-4639	
European Union	Horizon Technischer Service Sales: Horizon Hobby GmbH	service@horizonhobby.eu +49 (0) 4121 2655 100	Hanskampring 9 D 22885 Barsbüttel, Germany

FCC Information



Contains FCC ID: BRWWAC01T

This equipment complies with FCC and IC radiation exposure limits set forth for an uncontrolled environment. This equipment should be installed and operated with minimum distance 20cm between the radiator and/or antenna and your body (excluding fingers, hands, wrists, ankles and feet). This transmitter must not be co-located or operating in conjunction with any other antenna or transmitter.

Supplier's Declaration of Conformity

EFL UMX Air Tractor BNF Basic (EFLU16450)

This device complies with part 15 of the FCC Rules. Operation is subject to the following two conditions: (1) This device may not cause harmful interference, and (2) this device must accept any interference received, including interference that may cause undesired operation.



CAUTION: Changes or modifications not expressly approved by the party responsible for compliance could void the user's authority to operate the equipment.

NOTE: This equipment has been tested and found to comply with the limits for a Class B digital device, pursuant to part 15 of the FCC Rules. These limits are designed to provide reason-

able protection against harmful interference in a residential installation. This equipment generates, uses and can radiate radio frequency energy and, if not installed and used in accordance with the instructions, may cause harmful interference to radio communications. However, there is no guarantee that interference will not occur in a particular installation. If this equipment does cause harmful interference to radio or television reception, which can be determined by turning the equipment off and on, the user is encouraged to try to correct the interference by one or more of the following measures:

- Reorient or relocate the receiving antenna.
- Increase the separation between the equipment and receiver.
- Connect the equipment into an outlet on a circuit different from that to which the receiver is connected.
- Consult the dealer or an experienced radio/TV technician for help.

Horizon Hobby, LLC
2904 Research Rd.
Champaign, IL 61822
Email: compliance@horizonhobby.com
Web: HorizonHobby.com

IC Information

CAN ICES-3 (B)/NMB-3(B)

Contains IC: 6157A-WAC01T

This device contains license-exempt transmitter(s)/receivers(s) that comply with Innovation, Science, and Economic Development Canada's license-exempt RSS(s). Operation is subject to the following 2 conditions:

1. This device may not cause interference.
2. This device must accept any interference, including interference that may cause undesired operation of the device.

Compliance Information for the European Union



EU Compliance Statement:

EFL UMX Air Tractor BNF Basic

(EFLU16450): Hereby, Horizon Hobby, LLC

declares that the device is in compliance with the following: EU Radio Equipment Directive 2014/53/EU, RoHS 2 Directive 2011/65/EU, RoHS 3 Directive - Amending 2011/65/EU Annex II 2015/863.

The full text of the EU declaration of conformity is available at the following internet address: <https://www.horizonhobby.com/content/support-render-compliance>.

Receiver:

2402–2478 MHz
1.43dBm



E328

EU Manufacturer of Record:

Horizon Hobby, LLC
2904 Research Road
Champaign, IL 61822 USA

EU Importer of Record:

Horizon Hobby, GmbH
Hanskampring 9
22885 Barsbüttel Germany

WEEE NOTICE:



This appliance is labeled in accordance with European Directive 2012/19/EU concerning waste of electrical and electronic equipment (WEEE). This label indicates that this product should not be disposed of with household waste. It should be deposited at an appropriate facility to enable recovery and recycling.



©2023 Horizon Hobby, LLC.

E-flite, AS3X, UMX, DSM, DSM2, DSMX, ModelMatch, Bind-N-Fly, the Bind-N-Fly logo and the Horizon Hobby logo are trademarks or registered trademarks of Horizon Hobby, LLC.

The Spektrum trademark is used with permission of Bachmann Industries, Inc. and are used under license by Horizon Hobby, LLC.

All other trademarks, service marks and logos are property of their respective owners.

US 8,672,726 US 9,056,667 US 9,753,457. US 10,078,329. US 9,930,567. US 10,419,970. Other patents pending.
<http://www.horizonhobby.com/>