

**Eflite**<sup>®</sup>  
ADVANCING ELECTRIC FLIGHT

# EXTRA<sup>3</sup>00 3D

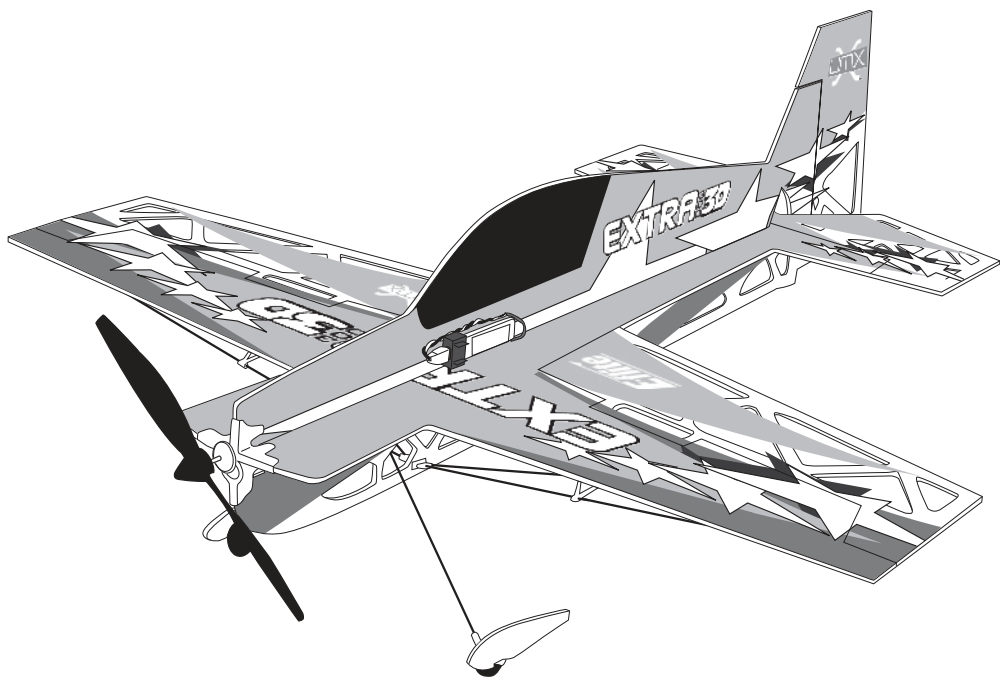

**Instruction Manual**  
**Bedienungsanleitung**  
**Manuel d'utilisation**  
**Manuale di Istruzioni**



BIND-N-FLY SPEKTRUM DSM2 TECHNOLOGY

**NOTICE**

All instructions, warranties and other collateral documents are subject to change at the sole discretion of Horizon Hobby, Inc. For up-to-date product literature, visit [horizonhobby.com](http://horizonhobby.com) and click on the support tab for this product.

**Meaning of Special Language**

The following terms are used throughout the product literature to indicate various levels of potential harm when operating this product:

**NOTICE:** Procedures, which if not properly followed, create a possibility of physical property damage AND a little or no possibility of injury.

**CAUTION:** Procedures, which if not properly followed, create the probability of physical property damage AND a possibility of serious injury.

**WARNING:** Procedures, which if not properly followed, create the probability of property damage, collateral damage, and serious injury OR create a high probability of superficial injury.



**WARNING:** Read the ENTIRE instruction manual to become familiar with the features of the product before operating. Failure to operate the product correctly can result in damage to the product, personal property and cause serious injury.

This is a sophisticated hobby product. It must be operated with caution and common sense and requires some basic mechanical ability. Failure to operate this Product in a safe and responsible manner could result in injury or damage to the product or other property. This product is not intended for use by children without direct adult supervision. Do not attempt disassembly, use with incompatible components or augment product in any way without the approval of Horizon Hobby, Inc. This manual contains instructions for safety, operation and maintenance. It is essential to read and follow all the instructions and warnings in the manual, prior to assembly, setup or use, in order to operate correctly and avoid damage or serious injury.

**Additional Safety Precautions and Warnings**

**Age Recommendation: Not for children under 14 years.** This is not a toy.

As the user of this product, you are solely responsible for operating it in a manner that does not endanger yourself and others or result in damage to the product or the property of others.

This model is controlled by a radio signal that is subject to interference from many sources outside your control. This interference can cause momentary loss of control so it is advisable to always keep a safe distance in all directions around your model, as this margin will help to avoid collisions or injury.

Never operate your model with low transmitter batteries.

Always operate your model in open spaces away from full-size vehicles, traffic and people.

Carefully follow the directions and warnings for this and any optional support equipment (chargers, rechargeable battery packs, etc.).

Keep all chemicals, small parts and anything electrical out of the reach of children.

Moisture causes damage to electronics. Avoid water exposure to all equipment not specifically designed and protected for this purpose.

Never lick or place any portion of your model in your mouth as it could cause serious injury or even death.

## Introduction

Designed for 3D aerobatics even in relatively small indoor spaces, the UMX Extra 300 3D utilizes micro light film over laser cut foam with carbon reinforcement to create an ultra lightweight aerobatic performer. Designed by ETOC Champion Seth Arnold, the UMX Extra 300 3D has been totally optimized to deliver extreme 3D performance for any experienced pilot. Charge the flight battery, dial in the proper setup to your transmitter, bind to the model and fly all-out 3D almost anywhere.

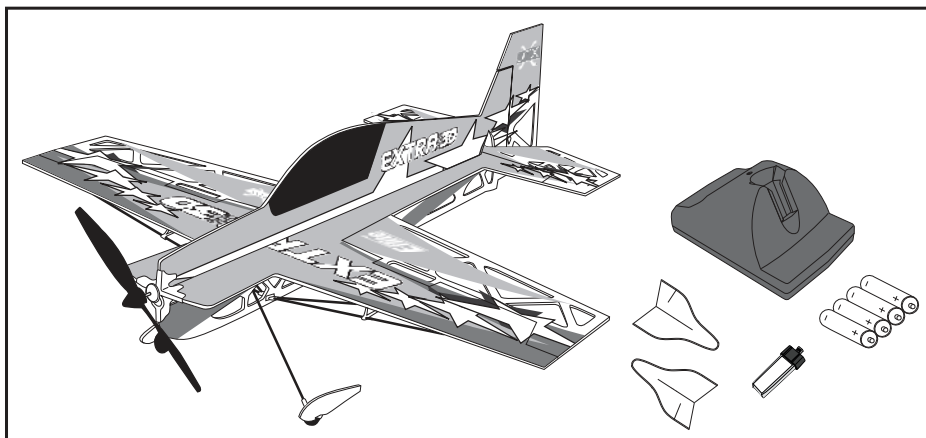

## Table of Contents

Additional Safety Precautions and Warnings.....	2	Flying Tips and Repairs.....	8
Battery Warnings .....	4	Maintenance After Flying .....	8
Charging the Battery .....	5	Installation of Side Force Generator (SFG) .....	9
Transmitter and Receiver Binding.....	6	Service of Power Components .....	9
Before Flight.....	6	Replacement Parts.....	10
First Flight Preparation .....	6	Optional Parts.....	10
Control Direction Test .....	7	Troubleshooting Guide.....	11
Control Centering.....	7	Warranty and Repair Policy.....	12
Settings for Control Horns.....	7	Contact Information.....	13
Adjusting Center of Gravity (CG).....	7	Declaration of Conformity .....	13
Dual Rates and Expo .....	8		

### UMX Extra 300 3D Specifications

Wingspan	<b>16.8 in (427mm)</b>
Length	<b>19.4 in (494mm)</b>
Weight	<b>0.98 oz (28 g) without battery</b> <b>1.2 oz (32.5 g) with battery</b>

To register your product online, go to [www.e-fliterc.com](http://www.e-fliterc.com)

## Battery Warnings

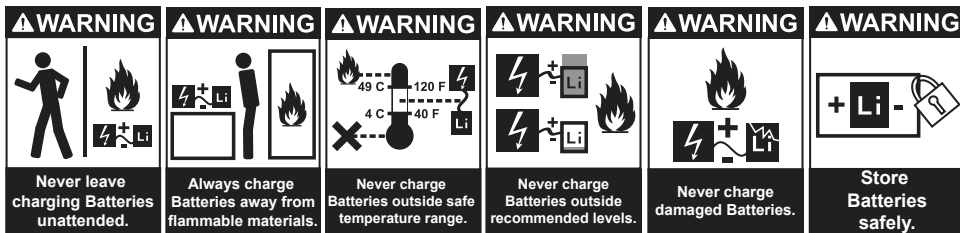

The Battery Charger (EFLC1003) included with the UMX Extra 300 3D has been designed to safely charge the Li-Po battery.

**CAUTION:** All instructions and warnings must be followed exactly. Mishandling of Li-Po batteries can result in a fire, personal injury, and/or property damage.

- By handling, charging or using the included Li-Po battery you assume all risks associated with lithium batteries. If you do not agree with these conditions, return your complete UMX Extra 300 3D model in new, unused condition to the place of purchase immediately.
- DO NOT USE A Ni-Cd OR Ni-MH CHARGER. Failure to charge the battery with a compatible charger may cause fire resulting in personal injury and/or property damage.
- If at any time the battery begins to balloon or swell, discontinue use immediately. If charging or discharging, discontinue and disconnect. Continuing to use, charge or discharge a battery that is ballooning or swelling can result in fire.
- Store the battery at room temperature in a dry area for best results.
- When transporting or temporarily storing the battery the temperature range should be from 40–120° F. Do not store battery or model in a car or direct sunlight. If stored in a hot car, the battery can be damaged or even catch fire.
- Li-Po cells should not be discharged to below 3V each under load.
- Do not cover warning labels with hook and loop strips.

**WARNING:** Only use an E-flite 6V power supply with this charger. DO NOT use a 12V power supply or property damage and injury could occur.

### Low Voltage Cutoff (LVC)

When a Li-Po battery is discharged below 3V per cell, it will not hold a charge. The UMX Extra 300 3D ESC protects the flight battery from over-discharge using Low Voltage Cutoff (LVC). Before the battery charge decreases too much, LVC removes power supply from the motor. Power to the motor decreases and increases, showing some battery power is reserved for flight control and safe landing.

When the motor power decreases then increases, please land the aircraft immediately and recharge the flight battery.

Disconnect and remove the Li-Po battery from the aircraft after use to prevent trickle discharge. Before storage, charge the Li-Po battery to full capacity. During storage make sure battery charge does not go below 3V per cell.

**NOTICE:** Repeated flying to LVC will damage the battery.

## Charging the Battery

Your UMX Extra 300 3D comes with a 1S 3.7V Li-Po Battery Charger and 150mAh 1-Cell 3.7V 12C Li-Po battery. It is important that you only charge with the included charger, or the E-flite® Celectra™ 4-port Charger (EFLC1004). Refer to battery warnings. We recommend you charge the battery pack first. You will need the flight battery to confirm proper aircraft operation in future steps.

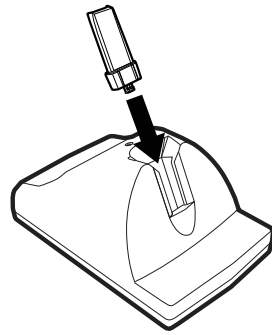

### The Battery Charging Process

1. Charge only batteries that are cool to the touch and are not damaged. Look at the battery to make sure it is not damaged e.g., swollen, bent, broken or punctured.
2. Remove the cover on the bottom of the charger and install four of the included AA batteries, noting proper polarity. Replace the cover after the AA batteries are installed.
3. Slide the battery into the slot on the charger. The end cap of the battery is specifically designed to allow the battery to fit into the slot one way (usually with the label on the battery facing outward) to prevent reverse polarity connection. However, check for proper alignment and polarity before proceeding to the next step.
4. Gently press the battery and its connector into the charge jack/connector located at the bottom of the slot in the charger.
5. When you make the connection successfully, the LED on the charger turns solid red, indicating charging has begun.
6. Charging a fully discharged (not over-discharged) 150mAh battery takes approximately 25–30 minutes. As the battery nears full charge, the LED begins to blink.
7. When the battery is fully charged, the LED blinks approximately every 20 seconds or goes out entirely. **Note:** If the LED stays on when the Li-Po is removed, the AA batteries in the charger are low.
8. Always unplug the battery from the charger immediately upon completion of charging.

**⚠ CAUTION:** Overcharging a battery can cause a fire.

**⚠ WARNING:** Failure to use the proper charger for a Li-Po battery can result in serious damage, and if left charging long enough, will cause a fire. ALWAYS use caution when charging Li-Po batteries.

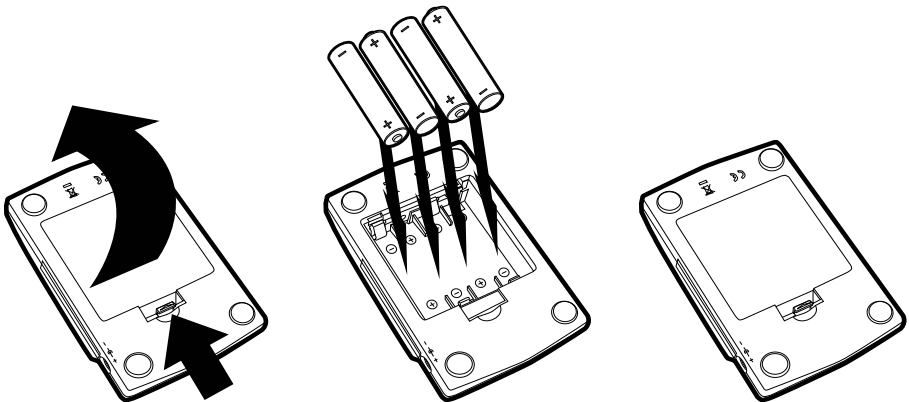

## Transmitter and Receiver Binding

Binding is the process of programming the receiver of the control unit to recognize the GUID (Globally Unique Identifier) code of a single specific transmitter. You need to 'bind' your chosen Spektrum DSM2 technology equipped aircraft transmitter to the receiver for proper operation.

**Note:** Any JR® or Spektrum DSM2 aircraft transmitter can bind to the Spektrum AR6400L receiver. Due to the aerobatic capabilities of the UMX Extra 300 3D, we recommend using a transmitter with adjustable exponential and dual rates. Please visit [www.bindnfly.com](http://www.bindnfly.com) for a complete list of compatible transmitters.

**Note:** When using a Futaba transmitter with a Spektrum DSM2 module, you will need to reverse the throttle channel.

### ✓ Binding Procedure

1. Refer to your transmitter's unique instructions for binding to a receiver.
2. Make sure the flight battery is disconnected from the aircraft.
3. Power off your transmitter.
4. Connect the flight battery in the aircraft. The receiver LED will begin to flash rapidly (typically after 5 seconds).
5. Make sure transmitter controls are neutral and throttle and throttle trim are in low position.
6. Put your transmitter into bind mode. Refer to your transmitter's manual for binding button or switch instructions.
7. After 5 to 10 seconds, the receiver status LED will become solid, indicating the receiver is bound to the transmitter.  
**Note:** If the LED does not go to a solid light, refer to Troubleshooting Guide at back of manual.

## Before Flight

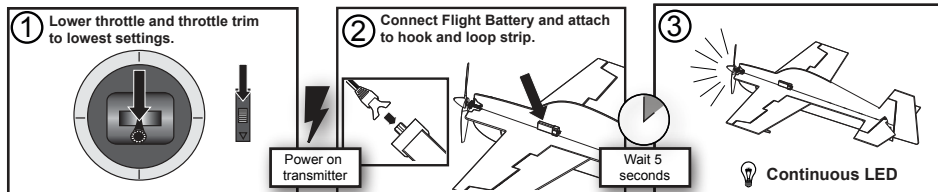

**Note:** Always disconnect the Li-Po from the receiver of the aircraft when not flying. Failure to do so will render the battery unusable.

**CAUTION:** When armed, the motor will turn the propeller in response to any throttle movement. When the aircraft does not respond, binding may be required.

## First Flight Preparation

- Remove and inspect contents
- Read this instruction manual thoroughly
- Bind aircraft to your transmitter
- Install the flight battery in the aircraft (once it has been fully charged)
- Make sure carbon fiber control rods move freely
- Make sure flight control surfaces are centered
- Perform the Control Direction Test with the transmitter
- Adjust flight controls and transmitter
- Adjust battery for center of gravity (CG)
- Perform a radio system Range Check
- Find a safe and open area
- Plan flight for flying conditions

## Control Direction Test

You should bind your aircraft and transmitter before doing these tests. Move the controls on the transmitter to make sure aircraft control surfaces move correctly and in the proper direction.

## Control Centering

Before first flights, or in the event of an accident, make sure the flight control surfaces are centered. Adjust pushrods mechanically. Adjustment only in the transmitter may not correctly adjust aircraft control surfaces due to mechanical limits of linear servos.

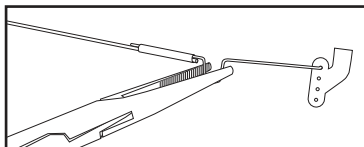

1. Make sure transmitter trims are neutral and control surfaces are centered. Where possible, transmitter sub-trim must be set to 0.
2. When needed, use a pair of pliers to carefully bend the metal of the pushrod (see illustration).
3. Make the U-shape narrower to make the pushrod shorter. Make the U-shape wider to make the pushrod longer.

**Note:** Do not use Sub-Trim to adjust the center position of the servo, and never set Travel adjust values above 100%. Ultra Micro servos are unique in that they are calibrated to reach maximum travel at 100%. Increasing the value above 100% will NOT result in more travel, but can cause the servo to lock and will result in poor flight characteristics.

## Settings for Control Horns

The picture here shows positions chosen for the most balanced aerobatic response. Changing this configuration dramatically affects aircraft response. Picture not to scale.

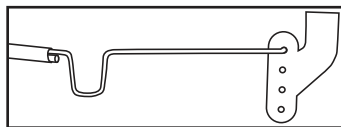

*Elevator, Aileron and Rudder Attachment*

## Adjusting Center of Gravity (CG)

The CG location is 82mm forward from the trailing edge of the aileron at the fuselage.

**Note:** Adjust CG by moving flight battery on fuselage.

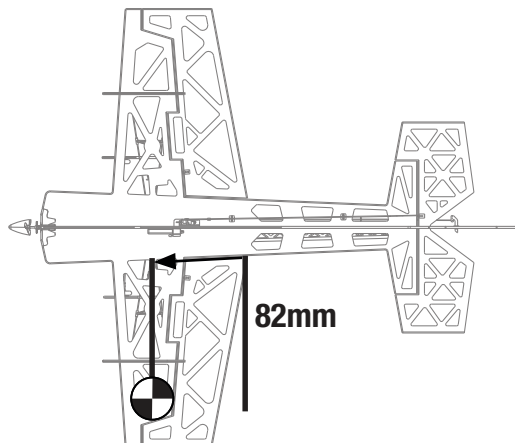

## Dual Rates and Expo

We recommend using a DSM2 radio capable of dual rates and expo. Adjust according to individual preferences after initial flight. The DX5e transmitter is not recommended.

**NOTICE:** DO NOT SET YOUR TRANSMITTER ATV OVER 100%. If the ATV is set over 100% it will not result in more control movement, and it will overdrive the servo and cause damage.



**CAUTION:** Pushrod connections on control horns directly affect aircraft response.

When these are incorrectly connected for the pilot's skill level, unexpected aircraft response to controls can result. This can cause damage to the aircraft and personal injury.

## Dual Rates

	Low	High	3D
Aileron	50%	65%	100%
Elevator	40%	55%	100%
Rudder	50%	70%	100%

## Expo

	Low	High	3D
Aileron	25%	40%	50%
Elevator	15%	25%	45%
Rudder	20%	35%	45%

## Flying Tips and Repairs

### Flying

For the initial flights the UMX Extra 300 3D should be flown in a gymnasium or large open space.

If flown outdoors, fly only in an open yard or driveway and in VERY low winds. You should also be careful to avoid flying in areas where there are many people, such as busy parks, schoolyards, or soccer fields. Consult local laws and ordinances before choosing a location to fly your aircraft.

Set all control surfaces at **low rate**. Place the UMX Extra 300 3D in position for takeoff (facing into the wind, if outdoors). Gradually increase the throttle to  $\frac{3}{4}$  to full, and steer with the rudder. Pull back gently with the elevator and climb to check trim. Once the trim is adjusted, begin exploring the flight envelope of the UMX Extra 300 3D.

**Note:** Always fully lower the throttle when the aircraft lands to prevent damage to the ESC.

**Note:** Crash damage is not covered under warranty.

Heat, direct sunlight or crash damage can wrinkle the film covering on the aircraft. This will not decrease aircraft performance.

### Repairs

Thanks to the construction of the UMX Extra 300 3D, repairs to the foam can be made using foam-safe CA or tape. When parts are not repairable, see the Replacement Parts List for ordering by item number.

## Maintenance After Flying

- Disconnect flight battery from ESC (Required for Safety)
- Power off transmitter
- Remove flight battery from aircraft
- Recharge flight battery

- Repair or replace all damaged parts
- Store flight battery apart from aircraft and monitor the battery charge
- Make note of flight conditions and flight plan results, planning for future flights

For current product information, go to [www.e-fliterc.com](http://www.e-fliterc.com)

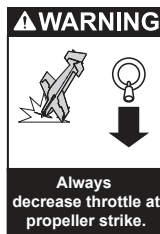



## Installation of Side Force Generator (SFG)

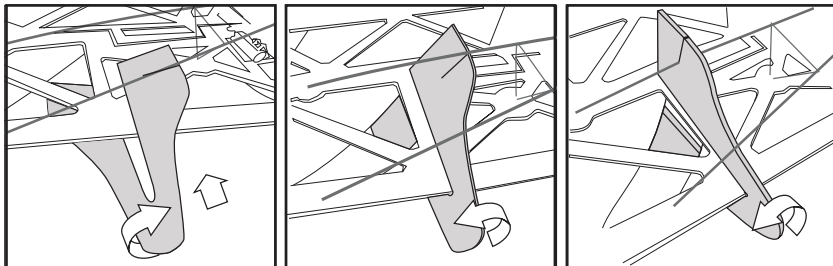

SFGs help with knife-edge flying. They add side force in all attitudes which greatly increases rudder authority making a variety of 3D aerobatics possible. However, installation is optional.

1. Turn SFG so it is near flat in relation to the wing.
2. Lower part of SFG with pre-cut slot must go under carbon wing supports.

3. Put channel in SFG on wing.
4. Turn SFG carefully so rear support goes in slot in SFG (see illustration).
5. Attach SFG to wing and carbon supports using foam-safe CA.
6. Attach an SFG on other wing using instructions above.

## Service of Power Components

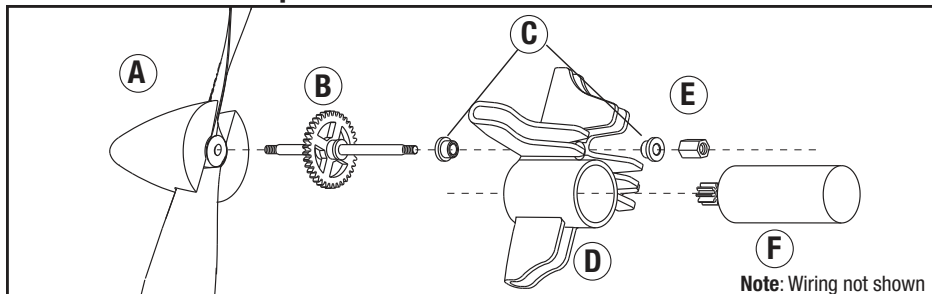

**Note:** Wiring not shown



**CAUTION:** DO NOT handle propeller parts while the flight battery is connected. Personal injury could result.

### Disassembly

- Hold the shaft (B) using needle-nose pliers or hemostats.
- Remove the propeller (A) by turning it counterclockwise on the threaded shaft (B).
- Hold the nut (E) on the shaft (B) using needle-nose pliers or hemostats.
- Turn the spur gear on the shaft (B) clockwise to remove the nut.
- Gently pull the shaft (B) from the gearbox (D).

**Note:** Make sure bushings (C) are not lost when gear shaft is removed from the gearbox.

### Assembly

- Turn a 130mm x 70mm propeller (A) clockwise on the shaft.

**Note:** Numbers on the propeller must face out from fuselage for correct propeller operation.

- Install the shaft (B) in the gearbox (D).
- Hold the nut (E) on the back of the shaft (B).
- Turn the spur gear (B) counterclockwise until the nut is tightly installed on the shaft (B).

**Note:** Carefully align gear shaft (B) with pinion gear on motor (F).

**Note:** Avoid disconnecting motor from receiver. When motor is connected to the receiver, make sure wire connectors are correctly aligned so motor turns the propeller in the correct direction.

## Replacement Parts

Number	Description
EFLU1053	Gearbox with Propeller Shaft: UMX Extra 300 3D
EFLU1055	Landing Gear with Mounts: UMX Extra 300 3D
EFLU1056	Hardware Set: UMX Extra 300 3D
EFLU1057	Wing Bracing with Mounts: UMX Extra 300 3D
EFLU1070	Replacement Airframe: UMX Extra 300 3D
EFL9051	Propeller with Spinner (2): 130mm x 70mm
EFL9052	Motor: UMX 4Site/Extra 300 3D
EFL9054	Prop Shaft With Gear (2): UMX 4-Site/Extra 300 3D
SPM6832	Replacement Servo Mechanics: Ultra Micro Long Throw
EFLH1067	Replacement Servo Retaining Collars
SPMAS2000L	1.7g-Linear Long Throw Servo
EFLB1501S	1S 3.7V 150mAh Li-Po Battery
PKZ3052	Battery Connector with Wire
SPMAR6400L	AR6400L DSM2 6 Channel Ultra Micro Receiver

## Optional Parts

Number	Description
EFLC1004	Celectra 4-Port 1S 3.7V 0.3A DC Li-Po Charger
EFLC1005	AC to 6VDC 1.5-Amp Power Supply (United States)
EFLC1005AU	AC to 6VDC 1.5-Amp Power Supply (Australia)
EFLC1005EU	AC to 6VDC 1.5-Amp Power Supply (Europe)
EFLC1005UK	AC to 6VDC 1.5-Amp Power Supply (United Kingdom)
SPMR6600	DX6i 6-Channel Transmitter Mode 2
SPMR66001	DX6i 6-Channel Transmitter Mode 1
SPMR6600E	DX6i 6-Channel Transmitter Mode 2 (Europe)
SPMR66001E	DX6i 6-Channel Transmitter Mode 1 (Europe)
SPM66001FR	DX6i 6-Channel Full Range Transmitter without servo Mode 1 (France)
SPM6600FR	DX6i 6-Channel Full Range Transmitter without servo Mode 2 (France)
SPMR7700	DX7 7-Channel Transmitter Mode 2
SPMR77001	DX7 7-Channel Transmitter Mode 1
SPM8800	DX8 with AR8000 Transmitter/Receiver Only
SPM8800EU	DX8 with AR8000 Transmitter/Receiver Only (Europe)
SPM88001AU	DX8 with AR8000 Transmitter/Receiver Only Mode 1 (Australia)
SPM88001FR	DX8 with AR8000 Transmitter/Receiver Only Mode 1 (France)

To purchase directly from Horizon Hobby, please visit [www.horizonhobby.com](http://www.horizonhobby.com) or call Horizon's Consumer Sales Division: (800) 338-4639.

For current product information, go to [www.e-fliterc.com](http://www.e-fliterc.com).

# Troubleshooting Guide

Problem	Possible Cause	Solution
Aircraft will not respond to throttle but responds to other controls	Throttle not at idle and/or throttle trim too high	Reset controls with throttle stick and throttle trim at lowest setting
	Throttle channel is reversed	Reverse throttle channel on transmitter
Extra propeller noise or extra vibration	Damaged propeller and spinner, propeller shaft or motor	Replace damaged parts
	Nut on prop shaft is too loose	Tighten the prop shaft nut 1/2 turn
Reduced flight time or aircraft underpowered	Flight battery charge is low	Completely recharge flight battery
	Propeller installed backwards	Install propeller with numbers facing forward
	Flight battery damaged	Replace flight battery and follow flight battery instructions
	Flight conditions may be too cold	Make sure battery is warm before use
	Battery capacity may be low for flight conditions	Replace battery or use a larger capacity battery
LED on receiver flashes rapidly and aircraft will not respond to transmitter (during binding).	Transmitter too near aircraft during binding process	Power off transmitter, move transmitter a larger distance from aircraft, disconnect and reconnect flight battery to aircraft and follow binding instructions.
	Aircraft not bound to transmitter	Bind transmitter to aircraft receiver
LED on receiver flashes rapidly and aircraft will not respond to transmitter (after binding).	Less than a 5-second wait between first powering on transmitter and connecting flight battery to aircraft	Leaving transmitter on, disconnect and reconnect flight battery to aircraft
	Aircraft bound to different model memory (ModelMatch radios only)	Select correct model memory on transmitter and disconnect and reconnect flight battery to aircraft
	Flight battery/Transmitter battery charge is too low	Replace/recharge batteries
Control surface does not move	Control surface, control horn, linkage or servo damage	Replace or repair damaged parts and adjust controls
	Wire damaged or connections loose	Do a check of wires and connections, connect or replace as needed
	Flight battery charge is low	Fully recharge flight battery
	Carbon fiber control rods stuck on support	Free carbon fiber control rods from support
Controls reversed	Transmitter settings reversed	Do the Control Direction Test and adjust controls on transmitter appropriately
Motor loses power	Damage to motor, propeller shaft or power components	Do a check of batteries, transmitter, receiver, motor and wiring for damage (replace as needed)
	Nut on prop shaft is too tight	Loosen prop shaft nut until propeller shaft turns freely
Motor power decreases and increases then motor loses power	Receiver uses default soft Low Voltage Cutoff (LVC)	Recharge flight battery or replace battery that is no longer performing
Servo reaches full travel before transmitter stick is at maximum deflection.	Radio has sub-trim set to value other than 0, or Travel adjust value is set above 100%	Set sub-trim to 0, and/or set Travel adjust to 100% or less, then mechanically adjust pushrod length to re-center surfaces.

## Warranty and Repair Policy

### Warranty Period

Exclusive Warranty- Horizon Hobby, Inc., (Horizon) warranties that the Products purchased (the "Product") will be free from defects in materials and workmanship at the date of purchase by the Purchaser.

### Limited Warranty

**Horizon reserves the right to change or modify this warranty without notice and disclaims all other warranties, express or implied.**

(a) This warranty is limited to the original Purchaser ("Purchaser") and is not transferable. REPAIR OR REPLACEMENT AS PROVIDED UNDER THIS WARRANTY IS THE EXCLUSIVE REMEDY OF THE PURCHASER. This warranty covers only those Products purchased from an authorized Horizon dealer. Third party transactions are not covered by this warranty. Proof of purchase is required for all warranty claims.

(b) Limitations- HORIZON MAKES NO WARRANTY OR REPRESENTATION, EXPRESS OR IMPLIED, ABOUT NON-INFRINGEMENT, MERCHANTABILITY OR FITNESS FOR A PARTICULAR PURPOSE OF THE PRODUCT. THE PURCHASER ACKNOWLEDGES THAT THEY ALONE HAVE DETERMINED THAT THE PRODUCT WILL SUITABLY MEET THE REQUIREMENTS OF THE PURCHASER'S INTENDED USE.

(c) Purchaser Remedy- Horizon's sole obligation hereunder shall be that Horizon will, at its option, (i) repair or (ii) replace, any Product determined by Horizon to be defective. In the event of a defect, these are the Purchaser's exclusive remedies. Horizon reserves the right to inspect any and all equipment involved in a warranty claim. Repair or replacement decisions are at the sole discretion of Horizon. This warranty does not cover cosmetic damage or damage due to acts of God, accident, misuse, abuse, negligence, commercial use, or modification of or to any part of the Product. This warranty does not cover damage due to improper installation, operation, maintenance, or attempted repair by anyone other than Horizon. Return of any Product by Purchaser must be approved in writing by Horizon before shipment.

### Damage Limits

HORIZON SHALL NOT BE LIABLE FOR SPECIAL, INDIRECT OR CONSEQUENTIAL DAMAGES, LOSS OF PROFITS OR PRODUCTION OR COMMERCIAL LOSS IN ANY WAY CONNECTED WITH THE PRODUCT, WHETHER SUCH CLAIM IS BASED IN CONTRACT, WARRANTY, NEGLIGENCE, OR STRICT LIABILITY. Further, in no event shall the liability of Horizon exceed the individual price of the Product on which liability is asserted. As Horizon has no control over use, setup, final assembly, modification or misuse, no liability shall be assumed nor accepted for any resulting damage or injury. By the act of use, setup or assembly, the user accepts all resulting liability.

If you as the Purchaser or user are not prepared to accept the liability associated with the use of this Product, you are advised to return this Product immediately in new and unused condition to the place of purchase.

Law: These Terms are governed by Illinois law (without regard to conflict of law principals).

### WARRANTY SERVICES

#### Questions, Assistance, and Repairs

Your local hobby store and/or place of purchase cannot provide warranty support or repair. Once assembly, setup or use of the Product has been started, you must contact Horizon directly. This will enable Horizon to better answer your questions and service you in the event that you may need any assistance. For questions or assistance, please direct your email to [productsupport@horizonhobby.com](mailto:productsupport@horizonhobby.com), or call 877.504.0233 toll free to speak to a Product Support representative. You may also find information on our website at [www.horizonhobby.com](http://www.horizonhobby.com).

#### Inspection or Repairs

If this Product needs to be inspected or repaired, please use the Horizon Online Repair Request submission process found on our website or call Horizon to obtain a Return Merchandise Authorization (RMA) number. Pack the Product securely using a shipping carton. Please Note that original boxes may be included, but are not designed to withstand the rigors of shipping without additional protection. Ship via a carrier that provides tracking and insurance for lost or damaged parcels, as Horizon is not responsible for merchandise until it arrives and is accepted at our facility. An Online Repair Request is available at [www.horizonhobby.com](http://www.horizonhobby.com) under the Repairs tab. If you do not have internet access, please contact Horizon Product Support to obtain a RMA number along with instructions for submitting your product for repair. When calling Horizon, you will be asked to provide your complete name, street address, email address and phone number where you can be reached during business hours. When sending product into Horizon, please include your RMA number, a list of the included items, and a brief summary of the problem. A copy of your original sales receipt must be included for warranty consideration. Be sure your name, address, and RMA number are clearly written on the outside of the shipping carton.

**Notice: Do not ship batteries to Horizon. If you have any issue with a battery, please contact the appropriate Horizon Product Support office.**

#### Warranty Inspection and Repairs

**To receive warranty service, you must include your original sales receipt verifying the proof-of-purchase date.** Provided warranty conditions have been met, your Product will be repaired or replaced free of charge. Repair or replacement decisions are at the sole discretion of Horizon.

#### Non-Warranty Repairs

**Should your repair not be covered by warranty the repair will be completed and payment will be required without notification or estimate of the expense unless the expense exceeds 50% of the retail purchase cost.** By submitting the item for repair you are agreeing to payment of the repair without notification. Repair estimates are available upon request. You must include this request with your repair. Non-warranty repair estimates will be billed a minimum of 1 hour of labor. In addition you will be billed for return freight. Horizon accepts money orders and cashiers checks, as well as Visa, MasterCard, American Express, and Discover cards. By submitting any item to Horizon for inspection or repair, you are agreeing to Horizon's Terms and Conditions found on our website under the Repairs tab.

## Contact Information

Country of Purchase	Horizon Hobby	Address	Phone Number/Email Address
United States of America	Horizon Service Center (Electronics and engines)	4105 Fieldstone Rd Champaign, Illinois 61822 USA	877-504-0233 Online Repair Request: visit <a href="http://www.horizonhobby.com/repairs">www.horizonhobby.com/repairs</a>
	Horizon Product Support (All other products)	4105 Fieldstone Rd Champaign, Illinois 61822 USA	877-504-0233 <a href="mailto:productsupport@horizonhobby.com">productsupport@horizonhobby.com</a>
United Kingdom	Horizon Hobby Limited	Units 1-4 Ployters Rd Staple Tye Harlow, Essex CM18 7NS United Kingdom	+44 (0) 1279 641 097 <a href="mailto:sales@horizonhobby.co.uk">sales@horizonhobby.co.uk</a>
Germany	Horizon Technischer Service	Hamburger Str. 10 25335 Elmshorn Germany	+49 4121 46199 66 <a href="mailto:service@horizonhobby.de">service@horizonhobby.de</a>
France	Horizon Hobby SAS	14 Rue Gustave Eiffel Zone d'Activité du Réveil Matin 91230 Montgeron	+33 (0) 1 60 47 44 70 <a href="mailto:infofrance@horizonhobby.com">infofrance@horizonhobby.com</a>

## Compliance Information for the European Union

### Declaration of Conformity

(in accordance with ISO/IEC 17050-1)

No. HH2010083003



Product(s): EFL UMX Extra 300 3D BNF  
Item Number(s): EFLU1080  
Equipment class: 1

The object of declaration described above is in conformity with the requirements of the specifications listed below, following the provisions of the European R&TTE directive 1999/5/EC:

**EN 301 489**

General EMC requirements

Signed for and on behalf of:

Horizon Hobby, Inc.

Champaign, IL USA

Aug 30, 2010

Steven A. Hall  
Vice President  
International Operations and Risk  
Management  
Horizon Hobby, Inc.

## Instructions for disposal of WEEE by users in the European Union

This product must not be disposed of with other waste. Instead, it is the user's responsibility to dispose of their waste equipment by handing it over to a designated collections point for the recycling of waste electrical and electronic equipment. The separate collection and recycling of your waste equipment at the time of disposal will help to conserve natural resources and make sure that it is recycled in a manner that protects human health and the environment. For more information about where you can drop off your waste equipment for recycling, please contact your local city office, your household waste disposal service or where you purchased the product.





© 2010 Horizon Hobby, Inc.

US D578,146. PRC ZL 200720069025.2

The Spektrum trademark is used with permission of Bachmann Industries, Inc.

E-flite, Bind-N-Fly, Hangar 9, JR, UMX, DSM2 and Celectra are trademarks or registered trademarks of Horizon Hobby, Inc.

Futaba is a registered trademark of Futaba Denshi Kogyo Kabushiki Kaisha Corporation of Japan.

Created 10/10 28713

EFLU1080