

# Instruction Manual

ARF and ARFSV

# ULTIMATE 70cc



*Giuseppe Tompazini*

**FLEX**  
INNOVATIONS™



**BEFORE CONTINUING WITH THIS INSTRUCTION MANUAL OR THE ASSEMBLY OF YOUR AIRCRAFT, PLEASE VISIT OUR WIKI SUPPORT SITE FOR THE LATEST PRODUCT UPDATES, FEATURE CHANGES AND MANUAL ADDENDUMS FOR THIS PRODUCT.**

[wiki.flexinnovations.com/wiki/Ultimate70cc](http://wiki.flexinnovations.com/wiki/Ultimate70cc)

# TABLE OF CONTENTS

<b>Introduction</b> .....	<b>1</b>
Specifications: .....	1
Required Equipment: .....	2
Optional Equipment: .....	3
Hangar 9®/Ultracote®/Oracover® Colors:.....	4
<b>Using this Manual</b> .....	<b>5</b>
<b>ARF</b> .....	<b>7</b>
<b>Interplane Strut, Wing Strut Block Installation</b> .....	<b>7</b>
<b>Aileron Control Horn Installation</b> .....	<b>10</b>
Control Horn Installation .....	10
Hinge Installation:.....	12
<b>Wing Servos and Linkages Installation</b> .....	<b>13</b>
Ailerons.....	13
<b>Elevator Installation</b> .....	<b>15</b>
Control Horn Installation .....	15
Hinge Installation:.....	16
<b>Elevator Servo and Linkage Installation</b> .....	<b>17</b>
<b>ARF and ARFSV</b> .....	<b>20</b>
<b>Rudder, Tailwheel Installation</b> .....	<b>20</b>
Tail Wheel Installation .....	20
Rudder and Rudder Control Horn Installation .....	21
Rudder Control Horn Installation.....	22
Rudder Installation .....	23
<b>Rudder Servo and Linkage Installation</b> .....	<b>24</b>
<b>Mounting the Stab</b> .....	<b>27</b>
<b>Landing Gear Installation</b> .....	<b>29</b>
<b>Engine and Throttle Servo Installation</b> .....	<b>32</b>
<b>DA-70 Engine Installation</b> .....	<b>32</b>
DA-70 Throttle Servo and Throttle Linkage Installation .....	34
<b>Ignition Installation</b> .....	<b>36</b>
<b>Fuel Tank Installation</b> .....	<b>38</b>
<b>Exhaust and Cowling Installation</b> .....	<b>40</b>
Muffler Installation (A) .....	40
Canister Installation (B).....	42
Baffle and Final Cowling Installation .....	44
<b>Electric Power Setup</b> .....	<b>49</b>
<b>Motor Installation</b> .....	<b>49</b>
<b>ESC Installation</b> .....	<b>50</b>

Battery Tray Installation .....	51
Motor/ESC Cooling .....	52
Center Wing Cabane Installation .....	53
Bottom Wing Tab Mounts Assembly .....	57
<b>Final Assembly .....</b>	<b>58</b>
Radio Installation .....	58
Field Assembly .....	60
Decal Installation .....	63
<b>Final Setup and Flying Notes.....</b>	<b>67</b>
Center of Gravity .....	67
Aura 8 Professional.....	68
Range Testing.....	68
Before First Flight .....	69
AMA Safety Code .....	69
Replacement Parts.....	70
Optional Accessories.....	71
<b>Limited Warranty .....</b>	<b>72</b>

# INTRODUCTION



The Flex Innovations Ultimate 70cc is a 33% scale model of Gordon Price's famous Ultimate 10-300. Based on his 1988 Tournament of Champions (TOC) winning freestyle model, designer, and World Champion Quique Somenzini, has brought the Ultimate design into the 21st Century. A large fuselage, short wings and airfoiled tail combine with a lightweight and strong, laminated black fiber structure, to take the Ultimate to a new and unprecedented level of performance.

The perfect wing loading, and absolute minimum control coupling are the key to great 3D and XA performance; the Ultimate 70cc excels in these areas. Not only does the Flex Innovations Ultimate 70cc excel in the air, but in its looks; Quique paid close attention to the scale shape to conserve the true lines and appearance of the full-scale counterpart.

The Flex Innovations Ultimate 70cc is a natural performer and with the biplane design experience of Quique Somenzini, it's a phenomenal airplane that excels in all facets of aerobatic flight.

## Specifications:

Wingspan:	73in (1854mm)
Length:	85in (2159mm)
Gas Weight: (DA-70 w/DA stock muffler)	20lbs (9.1kg)
Electric Weight: (Potenza 65cc w/12S 6200mAh)	21lbs 12oz (9.9kg)
Engine/Motor Size:	70-76cc

## Required Equipment:

### Radio Equipment & Servos:

Transmitter:	8+ channels
Receiver:	8+ channels, high-voltage capable
Receiver Battery:	(2) 2S 2000mAh 15C+ LiPos (FPZBR20002S15 recommended)
Receiver Battery Strap:	(1) Flex Hook and Loop Strap, 200 mm long (FPMA1012)
Aileron, Rudder, Elevators	(7) Minimum 400 oz/in (28 kg/cm)
Recommended servos:	Potenza DS494010HV brushless high voltage servo recommended

### Servo Arms:

Aileron, Elevators:	(6) 2-inch Single Arm Potenza 2-inch Clamping Servo Arm (FPZA1036) recommended
Rudder:	(1) 4-inch Double Arm Potenza 4-inch Clamping Servo Arm (FPZA1037) recommended

### Servo Extensions:

Ailerons:	(2) 6-inch (150 mm) Top Wing (2) 6-inch (150 mm) Bottom Wing
Ailerons: (To RX or Aura)	(2) 28-inch (710 mm) Top Wing (2) 12-inch (300 mm) Bottom Wing
Elevators:	(2) 36-inch (910 mm)
Servo Extension Safety Clips:	Flex Servo Connector Safety Clips (FPZA1040)

### Spinner:

Spinner:	5 inch (127 mm) Recommended Flex 5in Orange Spinner (FPM2126)
----------	--

### Gas Engine Setup

Engine:	70cc to 76cc Gasoline two-stroke engine Desert Aircraft DA-70 – FPMDA70 recommended
Exhaust:	Follow your engine manufacturer's recommendation, as well as local noise restrictions in your area. DA stock muffler set by Slimline (FPMDA70MUFFLER) recommended for DA-70
Other Exhaust Options:	MTW TDH110 Rear Discharge Canisters for the DA-70 KS 60 mm drop 2 to 1 header for the DA-70
Propeller:	Follow your engine manufacturer's recommendation. Flex Innovations Carbon Fiber 24x9 recommended for the DA-70
Engine Standoffs:	(4) 15 mm Aluminum Standoffs for DA-70

Throttle Servo:	FPM1124 recommended for DA-70 High Quality, Metal Gear Digital Servo Potenza DS49010BLHV servo recommended
Throttle Servo Extension:	24-inch (600 mm)
Ignition Regulator:	Follow your engine manufacturer's recommendation
Ignition Battery	2S 2000mAh 15C+ Li-Po Potenza 2S 2000mAh 15C Li-Po (FPZBR20002S15) recommended
Ignition Battery Strap:	Flex Hook and Loop Strap, 200 mm long (FPMA1012)
Fuel Tank Strap	Flex Hook and Loop Strap, 260mm long (FPMA1014) Flex Hook and Loop Strap, 220mm long (FPMA1013)
Fuel Dot:	McFueled Fuel Dot (FPMAMCFUELER)

### Electric Setup

Motor:	60-70cc Brushless Motor Equivalent Potenza High Performance 65cc 185KV Brushless Motor FPZM65CC recommended
ESC:	160A HV ESC Castle Creations Phoenix Edge 160HV, 50V ESC recommended
Flight Batteries:	2 x 6S 6200mAh Li-Pos Potenza 6S 6200mAh 40C Li-Pos (FPMB62006S40) recommended
Flight Battery Straps	(2) Flex Hook and Loop Strap, 300mm long (FPMA1016)
Propeller:	Follow your motor manufacturer's recommendation Mejzlik 25x12S recommended for Potenza 65cc Brushless Motor
Motor Standoffs:	(4) 2-½ inch (63mm) Motor Standoffs (provided with Potenza 65cc)
ESC Servo Extension:	24-inch (600 mm)

### Optional Equipment:

FPZAURA08PRO	Aura 8 Professional
FPM2019	24oz Lightweight Fuel/Smoke Tank (for smoke)
FPMHOLYG2	Holy Smokes G2 Smoke System
FPM2014	Flex Innovations Premium Wing and Tail Bag Set
FPM2124	Ultimate 70cc Pilot
ISDTD2	ISDT D2 Dual Port AC 200W Charger
FPM2128	Premium Vinyl Graphics Set Ultimate 70cc Orange Scheme (by Callie Graphics)

## Hangar 9®/Ultracote®/Oracover® Colors:

### Orange Scheme:

#### **Ultracote®**

Midnight Blue (HANU885)

Sky Blue (HANU975)

Orange (HANU877)

White (HANU870)

#### **Oracover®**

Dark Blue (21-052)

Sky Blue (21-053)

Orange 21-060

White 21-010



## USING THIS MANUAL

**This manual is for both the ARF and ARFSV versions.**

The manual is divided into sections to make the assembly of the airplane easier to follow.

If you have an ARFSV, some of the steps will be completed for you, however, it is important that you read through this entire instruction manual to familiarize yourself with this aircraft.

*Note:* the squares “□” next to each step that can be checked off to help you keep track of the steps that have been completed.

### ATTENTION

Read the ENTIRE instruction manual to become familiar with the features and assembly of the product before starting assembly. Failure to assemble or operate the product correctly can result in damage to the product, personal property and cause serious or fatal injury.

All instructions, warranties and other collateral documents are subject to change at the sole discretion of Flex Innovations, LLC. For up-to-date product literature, please visit our website at [www.flexinnovations.com](http://www.flexinnovations.com) and navigate to the product page for this product.

### WARNING

This is NOT a toy. This product is not intended for use by children under 14 years of age without direct adult supervision.

### IMPORTANT INFORMATION REGARDING WARRANTY

Please read our Warranty and Liability section before building this product. If you as the purchaser or user are not prepared to accept the liability associated with the use of this product, you are advised to return this product immediately in new and unused condition, in the original packaging material, to the place of purchase.

### SAFETY WARNINGS AND PRECAUTIONS

Protect yourself and others by following these basic safety guidelines.

1. This manual contains instructions for safety, operation, and maintenance. It is essential to read and follow all the instructions in the manual, prior to assembly, setup, or use, in order to operate correctly and avoid damage or serious injury.
2. In some cases, the written instructions may differ slightly from the photos. In those instances, the written instructions should be considered correct.
3. This model is not a toy, rather it is a sophisticated remote control hobby product and must be operated with caution and common sense. This product requires some basic mechanical ability. Failure to operate this product in a safe and responsible manner could result in injury, or damage to the product, or other property.
4. This model must be assembled according to these instructions. Do not alter or modify the model outside of these instructions provided by Flex Innovations, LLC, as doing so may render it unsafe and/or unflyable. You must take time to build straight, true, and strong. It is your responsibility to ensure the air worthiness of this product.
5. Use only compatible, appropriate components for the final assembly of this model. Ensure that the radio system is in functional condition, that the engine is appropriately sized for the model and that all other components are appropriate for use in this model as specified in this

instruction manual. All components must be installed correctly so that they operate correctly both on the ground and in the air.

6. Inspect and check operation of the model and all its components before every flight.
7. If you are not an experienced pilot, or have not flown a high-performance model before, it is recommended that you seek assistance from an experienced pilot in your R/C club for your first flights. If you're not a member of a club, the Academy of Model Aeronautics (AMA) has information about clubs in your area whose membership includes experienced pilots.
8. Keep the propeller area clear from such items as loose clothing, jewelry, long hair, or tools, as they can become entangled. Keep your hands and body parts away from the propeller as injury can occur.

## SPECIAL LANGUAGE DEFINITIONS

The following terms are used throughout the product literature to indicate various levels of potential harm when operating the product.

- NOTICE:** Procedures, which if not properly followed, create a possibility of physical property damage AND a liable or no possibility of injury.
- CAUTION:** Procedures, which if not properly followed, create a probability of physical property damage AND a possibility of serious injury.
- WARNING:** Procedures, which if not properly followed, create the probability of property damage, collateral damage and serious injury OR create a high probability of serious injury.

## IMPORTANT BEFORE ASSEMBLY

Carefully unpack your aircraft and inspect the parts. Review the manual and gather the required tools and supplies.

- Remove all parts from their plastic bags, inventory all items and closely examine all the major airframe components for damage. If any items are missing or you find damaged components, do not proceed. Please contact customer support.
- Use a covering iron with a covering sock on high heat to tighten the covering as necessary, paying special attention to the leading edges of the flying surfaces, hinge lines and stabilizer and wing saddle areas. Apply slight pressure over sheeted areas to thoroughly bond the covering to the wood. Use caution around seams to prevent inadvertently pulling them loose.
  - **Pro-Tip:** You can use a "Seal-It Pen" to permanently seal any sharp edges or corners of covering that may come loose in flight.
- Use thin CA to go over any important glue joints, such as the motor box, firewall, servo mounting rails and any other pre-assembled joints that may see high stress during flight.
- Gather all required components such as motor and radio equipment that will be used to equip the airplane. Create a new radio program in your transmitter and bind this model program to the receiver that will be used in the airplane
- **IMPORTANT NOTE:**  
The canopy is attached to the fuselage differently than you may have experienced with other aircraft. To remove it, remove the two screws. Slide the canopy to the rear (DO NOT LIFT UP). Once the canopy has been moved aft approximately 1/2-inch (12mm), lift at the rear and continue moving the canopy to the rear as it is lifted away from the fuselage.

# ARF

If your airplane is the ARF version start building from this page through the end of this manual.

## INTERPLANE STRUT, WING STRUT BLOCK INSTALLATION

### Required for this section

#### Components

- Top Wing Panels (2)
- Bottom Wing Panels (2)
- Interplane Strut Blocks (4)
- Interplane Struts (2)
- Interplane Strut Pins (4)

#### Tools

- Hobby Knife with a #11 blade
- Covering Iron/Trim Iron

#### Adhesives/Building Materials

- Isopropyl Alcohol
- 30-minute Epoxy
- Paper Towels
- Toothpicks
- Mixing Cups
- Mixing Sticks (something to mix epoxy with)
- Low Tack Tape



1. Locate the slots in the wing for the interplane strut block locations. These are located in the top of the bottom wings, and the bottom of the top wings. Each block is clearly label. When installing it, follow the labeled directions.  
Use a Hobby Knife with a #11 blade to carefully cut and remove the covering from the slot, leaving  $\frac{1}{8}$ -inch (3mm) extra covering on the inside of the slot. Cut the corners at a 45-degree angle and use a covering or trim iron to seal the extra covering down into the slot.

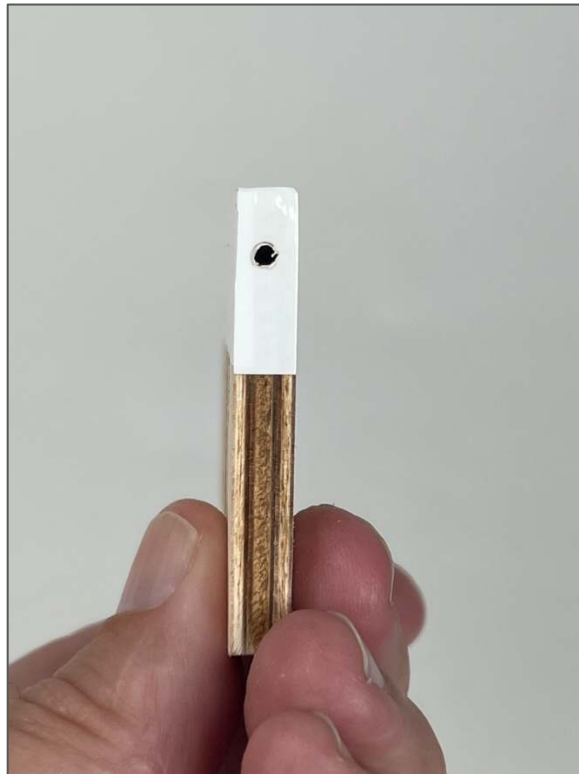

- 2. Each block needs to carefully cut and remove the covering from the holes for the mounting pin.



- 3. Take an interplane strut and assemble the corresponding block in position using the 3mm pin.



4. Do a test fit to confirm strut and block are in the correct location and fit with no issues into the slot in the wing.

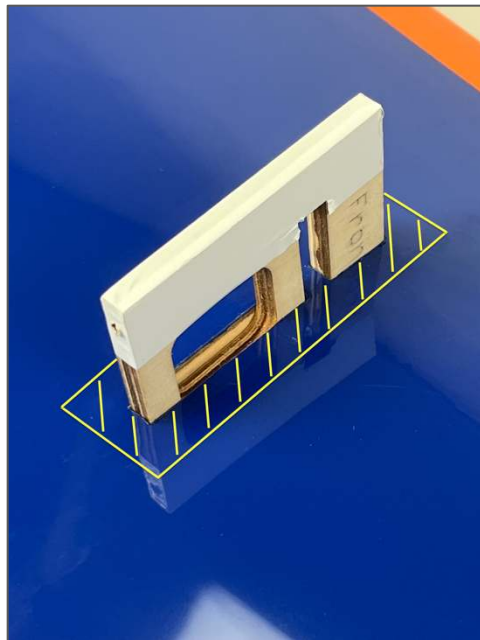

5. Once the fit is OK and you are ready to bond the blocks in, apply some low-tack tape around slot to ease epoxy cleanup. Use good quality, 30-minute Epoxy to bond the blocks in. Repeat this procedure for all 4 blocks.

### Quique's Tip:

While you are testing these parts, check that pin fits tight and is not loose. Pin should fit tight and might need the use of pliers to install and/or remove. If it is too loose, apply a thin layer of CA adhesive to the strut. **DO NOT USE ACCELERATOR** on the CA, let it cure naturally. If it is too tight, there may be some glue residue in the strut, clear it out with the pin or a small drill bit. Keep this tip in mind for future use, as the airplane accumulates flights it may be necessary to repeat this step.

## AILERON CONTROL HORN INSTALLATION

### Required for this section

#### Components

- Top Wing Panels (2)
- Bottom Wing Panels (2)
- Aileron Control Horns (8)
- Aileron Control Horn Base Plates (4)
- Aileron hinges (20)

#### Tools

- Hobby Knife with a #11 blade

#### Adhesives/Building Materials

- Isopropyl Alcohol
- 30-minute Epoxy
- Petroleum Jelly
- Paper Towels
- Toothpicks
- Mixing Cups
- Mixing Sticks (something to mix epoxy with)

### Control Horn Installation



1. Prepare the control horns by scuffing the portion of the control horn that is inserted into the control surface with medium grit sandpaper. Use isopropyl alcohol and a paper towel to clean the control horn and remove any debris left over after scuffing.

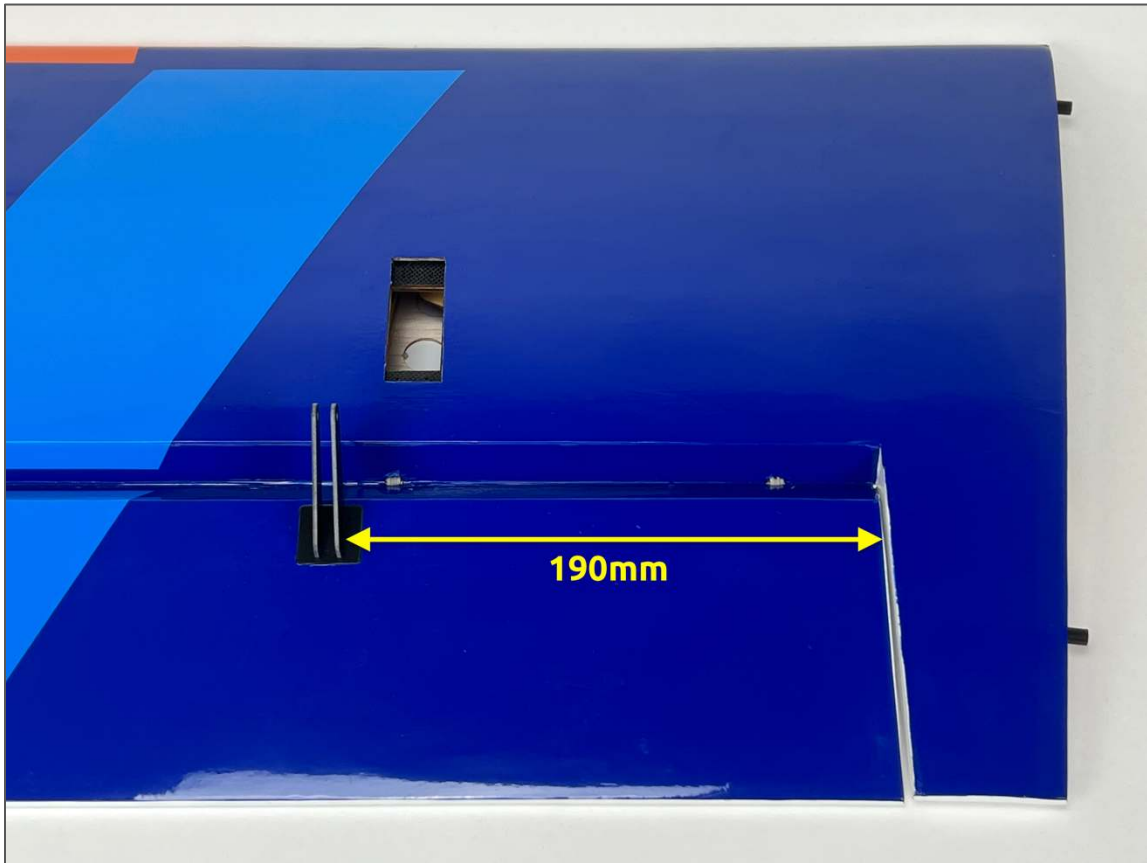

- 2. Locate the aileron control horn slots. You can find them close to the front edge of the control surface. Top and bottom wings are same distance.

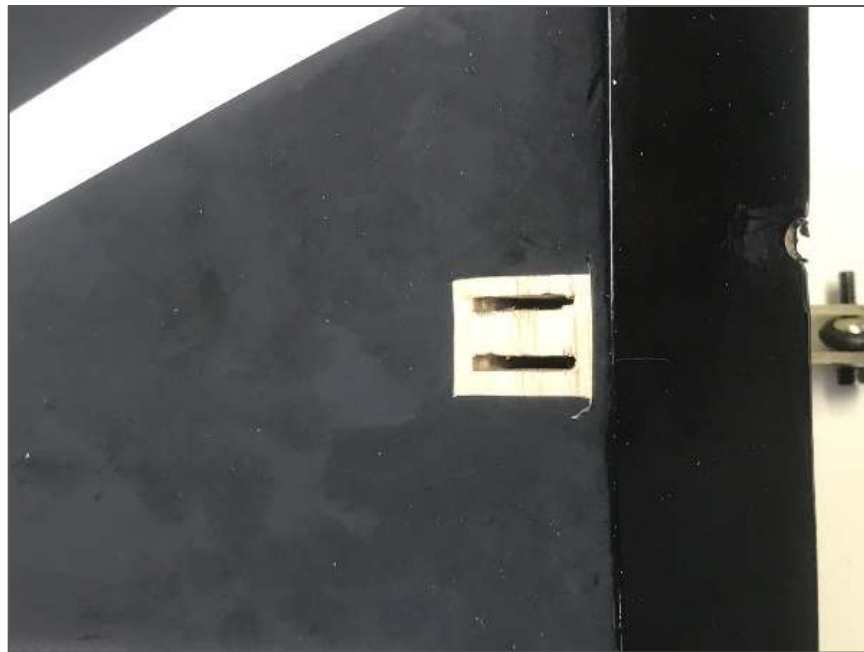

- 3. Use a Hobby Knife with a #11 blade to remove the covering for the control horn as shown in the picture above. You can open up the slots first and insert an assembled control horn to trace around the base plate to note the exact area from which covering should be removed.



- 4. Mix an adequate amount of 30-minute epoxy. Apply epoxy to the slot in the control surface as well as the control horns. Install the control horn and check for proper alignment. Use isopropyl alcohol and a paper towel to clean up any excess epoxy before it cures. Let it sit until the epoxy cures.

#### Quique's Tip:

To ensure proper alignment of each control horn, you can secure the ball link to the horns and then glue the horn in place with the ball link attached. This will ensure even alignment of both control horns.

#### Hinge Installation:

- 1. Use a Hobby Knife with a #11 blade to open holes in the covering for each hinge in the wings and ailerons. Test fit the hinges. Check for minimal hinge gap and overall alignment.
- 2. Use medium grit sandpaper to scuff the portion of each hinge that is inserted into the wing and aileron. Use isopropyl alcohol and a paper towel to clean the hinge and remove any debris that may be left after scuffing.
- 3. Use a toothpick or cotton swab to apply a small amount of petroleum jelly to the pivot point of each hinge. Do not apply petroleum jelly to the entire hinge. The petroleum jelly is used to prevent glue from adhering to the pivot of the hinge, keeping the hinge moving freely.
- 4. Mix an adequate amount of 30-minute epoxy and apply epoxy to the hinge slots in the ailerons. Insert a hinge into each slot in the aileron. Check for proper alignment. Use isopropyl alcohol and a paper towel to clean up any excess epoxy before it cures.
- 5. Repeat this process for gluing the hinges to the wing. Make sure the hinge gap is as tight as possible, while still allowing for proper control surface deflection. Use low-tack masking tape or equivalent to hold the in a neutral position. Wait at least 1 hour before removing the tape and testing the control surfaces.



## WING SERVOS AND LINKAGES INSTALLATION

### Required for this section

#### Components

- Top Wing Panels (2)
- Bottom Wing Panels (2)
- Aileron Linkage (4)
- Aileron Servos (4)
- Aileron Servo Arms (4)
- Top Wing Aileron servo extensions (2)
- Bottom Wing Aileron servo extensions (2)
- Ball Links (8)
- M3 x 15 Socket Head Cap Screw (8)
- M3 Washer (16)
- M3 Lock Nut (8)

#### Tools

- #1 Phillips Screwdriver
- 2.5mm Hex Driver
- 5.5mm Nut Driver
- Needle nose pliers

#### Adhesives/Building Materials

- Thin CA
- Blue Thread Lock
- Servo Connector Safety Clip

### Ailerons

1. Use a #1 Phillips screwdriver to thread a servo mounting screw into each of the pre-cut holes in the servo mounting rails in the wing. Remove the screw and apply a small amount of thin CA to each of the holes to harden the threads cut by the screw. Do not use CA accelerator. Let the CA fully cure before moving forward.
2. Secure a 9-inch (230 mm) servo extension to each of the two Bottom Wing Aileron servos. Use Flex Servo Connector Safety Clips (FPZA1040), heat shrink tubing or thread to secure the connection.
3. Secure a 6-inch (150 mm) servo extension to each of the two Top Wing Aileron servos. Use Flex Servo Connector Safety Clips (FPZA1040), heat shrink tubing or thread to secure the connection.
4. Insert the aileron servo into the servo bay with the output shaft towards the leading edge of the wing. Be sure to route the servo lead out of the wing before mounting the servo. Mount the servo to the wing using the servo mounting screws provided with your servos. Be sure to install the servos with the long servo extensions in the bottom wing panels and the servos with the shorter servo extensions in the top wing panels.
5. Using a pushrod with a length of 2 inches (50.8mm), assemble the aileron linkages so that the total length from center of ball to center of ball is approximately 70mm. Final length will be adjusted when centering the control surface. Note that the opposite ends of each aileron linkage have opposite direction threads. Also note that top wing and the bottom wing use the same pushrod length.
6. Attach the linkage to the servo arm. The correct hole location is 1 3/4-inches (44.4mm) from center. If using the recommended 2-inch servo arm, this is the second hole from the

end of the servo arm. The order of hardware components, starting from the top of the servo is as follows:

- M3x15 socket head cap screw
  - M3 washer
  - Ball Linkage
  - Servo Arm
  - M3 washer
  - M3 locknut
7. Use your radio system to center your aileron servos. Install your aileron servo arm onto the servo as close to parallel with the hinge line as possible. Apply blue thread lock to the servo arm screw and fully tighten the screw. If your servo arms have output shaft clamping screws, apply blue thread lock, and secure them in place as well.
8. With the radio powered-on and the servo centered so that the arm is parallel to the hinge line, adjust the linkage length so that the control surface is centered. When satisfied with the length of the linkage, secure the linkage to the control horn with the hardware in the following order:
- M3x15 Socket Head Cap Screw
  - M3 Washer
  - Control Horn (Side 1)
  - Ball Link
  - Control Horn (Side 2)
  - M3 Washer
  - M3 Lock Nut



After the steps above are completed and the servo and linkages are installed, the assembly should appear as shown in the picture above. Both ailerons should appear the same but mirrored accordingly.

*Note:* The angle of the linkage is correct. As the servo arm rotates and the control surface deflects, the linkage will straighten.

## ELEVATOR INSTALLATION

### Required for this section

#### Components

- Elevator Control Horn (4)
- Control Horn Base (2)
- Left and Right Horizontal Stabs

#### Tools

- Hobby Knife with a #11 Blade

#### Adhesives/Building Materials

- Isopropyl Alcohol
- 30-Minute Epoxy
- Paper Towels
- Mixing Cups
- Mixing Sticks
- Toothpicks

### Control Horn Installation

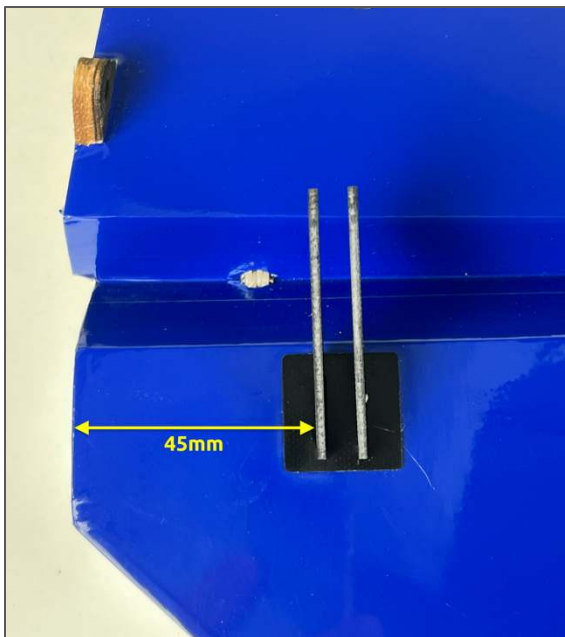

1. Use a hobby knife with a #11 blade to remove the covering from the bottom side of the elevators in the same way as was done with the ailerons. The control horn slots are approximately 1  $\frac{3}{4}$ -inches (45mm) from the elevator edge as shown in the picture.
2. The elevator horns are bagged and marked. Prepare the control horns by scuffing the portion of the control horn the extends into the control surface with medium grit sandpaper. Use isopropyl alcohol and a paper towel to clean the control horn and remove any excess debris left after scuffing.

- 3. Mix an adequate amount of 30-minute epoxy. Apply epoxy to the control horn slots in the elevator as well as the control horn. Push the control horns into the slot, being sure to wipe away any excess epoxy with isopropyl alcohol and a paper towel.

### Quique's Tip:

To better help align the control horns with one another, use the provided hardware to secure the control horns to the ball link. This will keep them aligned while they are glued in place.

### Hinge Installation:

- 1. Use a hobby knife with a #11 blade to open holes in the covering for each hinge in the horizontal stabs and elevators. Test fit the hinges. Check for minimal hinge gap and overall alignment.
- 2. Use medium grit sandpaper to scuff the portion of each hinge that is inserted into the horizontal stabs or elevators. Use isopropyl alcohol and a paper towel to clean the hinge and remove any debris that may be left after scuffing.
- 3. Use a toothpick or cotton swab to apply a small amount of petroleum jelly to the pivot point of each hinge. Do not apply petroleum jelly to the entire hinge. The petroleum jelly is used to prevent glue from adhering to the pivot of the hinge, keeping the hinge moving free.
- 4. Mix an adequate amount of 30-minute epoxy and apply epoxy to the hinge slots in the elevator. Insert a hinge into each slot in the elevator. Check for proper alignment. Use isopropyl alcohol and a paper towel to clean up any excess epoxy before it cures.
- 5. Repeat this process for gluing the hinges to the horizontal stabs. Make sure the hinge gap is as tight as possible, while still allowing for proper control surface deflection. Use masking tape or equivalent to hold the elevators in a neutral position. Wait at least 1 hour before removing the tape and testing the control surfaces.

## ELEVATOR SERVO AND LINKAGE INSTALLATION

### Required for this section

#### Components

- Horizontal Stabilizer Assemblies (2)
- Horizontal Stabilizer Carbon Fiber Tube
- Fuselage
- Elevator Servo (2)
- Elevator Servo Arm (2)
- Servo Extension (2)
- Left and Right Horizontal Stabs
- M3x15 Socket Head Cap Screw (8)
- M3 Washer (8)
- M3x12 Washer (4)
- M3 Lock Nut (4)

#### Tools

- #1 Phillips Screwdriver
- 2.5mm Hex Driver
- 5.5mm Nut Driver

#### Adhesives/Building Materials

- Servo Connector Safety Clip

1. Use a #1 Phillips screwdriver to thread a servo mounting screw into each of the holes in the servo mounting rails in the horizontal stabilizer. Remove the screw and apply a small amount of thin CA to each of the holes to harden the threads cut by the screw. Let the CA fully cure before moving forward.



2. Insert the elevator servo into the mounting location with the output shaft towards the leading-edge of the stab. Mount the servo to the stab using the mounting screws provided with your servos. Note that the servo wire will exit on the leading-edge side of the stab as shown in the picture above.
3. Power on your radio system to center the servo. Install a 2-inch (50.8mm) servo arm onto the servo. Apply a small amount of blue thread lock to the servo arm screw and secure it in place. If your servo arm has clamping screws, apply blue thread lock to these screws and secure them in place. Note that you may need to power off the model and rotate the servo arm by hand to have access to each clamping screw.

- 4. Using a pushrod of 2  $\frac{3}{4}$ -inch (70mm) length, assemble the elevator linkages and ball links so that the total length from center of ball to center of ball is approximately 3  $\frac{5}{8}$ -inches (92mm). Final length will be adjusted when centering the control surface. Note that both ends of the elevator linkages have opposite direction threads.
- 5. Attach the linkage to the servo arm. The correct hole location is 2-inches (50.8mm) from the center of the servo arm. If you are using the recommended servo arm, this is the hole at the end of the servo arm. The order of hardware components, starting from the top of the servo is as follows:
  - M3x15 socket head cap screw
  - M3 washer
  - Ball Linkage
  - Servo Arm
  - M3 washer
  - M3 locknut
- 6. Attach the linkage to the control horn. The order of hardware components, starting from the tip of the stabilizer is as follows:
  - M3x15 socket head cap screw
  - M3 washer
  - Control Horn #1
  - Ball Linkage
  - Control Horn #2
  - M3 washer
  - M3 locknut
- 7. With the radio powered on and the servo arm centered perpendicular to the servo case, adjust the linkage length so that the control surface is centered.

### Quique's Tip:

For elevator centering, it is best to install the stabilizers onto the fuselage and stand approximately 10 feet (3m) behind the aircraft while sighting the two elevator halves. Using this method, you can best align the most important part of the control surface, the widest part, rather than referencing something less important, like the elevator counterbalance.



- 8. After installation is complete, your linkage setup should match the image above. Repeat the same procedure for the other horizontal stabilizer.

## ARF AND ARFSV

If your airplane is an ARFSV you can start from this page.

However, for instructions on the assembly of the aileron, elevator pushrods, please reference the ARF steps on pages 7 through 19.

## RUDDER, TAILWHEEL INSTALLATION

### Required for this section

#### Components

- Fuselage
- Tail Gear Assembly
- Steering Ball Link (1)
- M3 X12mm Socket Head Cap Screw (2)
- M3 Flat Washer (2)

#### Tools

- Hobby Knife with #11 Blade
- 2.5mm Hex Driver
- Drill
- 4mm Drill Bit

#### Adhesives/Building Materials

- Thread Lock
- Isopropyl Alcohol
- 30-minute Epoxy
- Mixing Cups
- Mixing Sticks
- Paper Towels

### Tail Wheel Installation

1. Locate the (2) holes in the bottom of the fuselage close to the tail. Use a Hobby Knife with #11 blade to remove the covering and expose the holes.
2. Place a flat washer on each M3 X 12mm Socket Head Cap Screw.



3. Apply Thread Lock to the screws and use a 2.5mm hex driver to mount the tail gear assembly as show in picture above.





- 4. With a 4mm drill bit, drill a hole in the center of the rudder bottom side. Place this hole about 70mm from the leading edge.
- 5. Glue the steering ball link in the hole with 30 min Epoxy. Note: when you glue the ball link make sure the ball hole is perpendicular to the rudder leading edge so the steering arm can go through.

## Rudder and Rudder Control Horn Installation

### Required for this section

#### Components

- Rudder Control Horns (4)
- Rudder Control Horn Plates (2)
- Fuselage Assembly

#### Tools

- Hobby Knife with a #11 blade

#### Adhesives/Building Materials

- Isopropyl Alcohol
- 30-minute Epoxy
- Mixing Cups
- Mixing Sticks
- Paper Towels
- Petroleum Jelly
- Transparent tape

## Rudder Control Horn Installation

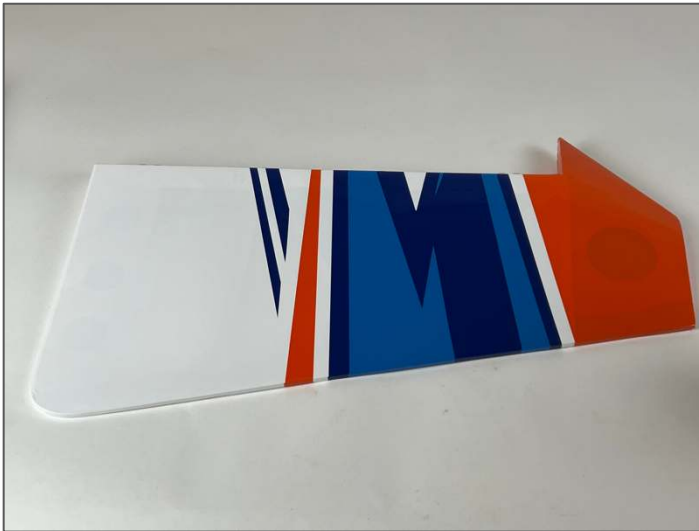

1. Locate the rudder. This model uses a pull-pull rudder setup so you will be installing a control horn on both sides of the rudder. Use a hobby knife with a #11 blade to remove the covering from BOTH sides of the rudder at the location shown in the picture above. You can open up the slots first and insert an assembled control horn to trace around the base plate to note the exact area from which covering should be removed.



2. You will need a total of (4) control horns and (2) control horn plates.
3. Prepare the control horns by sanding the portion of the control horn that extends into the control surface with medium grit sandpaper. Use isopropyl alcohol and a paper towel to clean the control horns and remove any excess debris from the control horn.

- 4. Mix an adequate amount of 30-minute epoxy. Apply epoxy to the control horn slots in the rudder as well as the control horn. Push the control horns into the slot, being sure to wipe away any excess epoxy with isopropyl alcohol and a paper towel. Align the control horns as shown in the picture above. Let the epoxy cure completely before proceeding with the rudder installation.

### Quique's Tip:

To ensure proper alignment of each control horn, you can secure the ball link to the horns and then glue the horn in place with the ball link attached. This will ensure even alignment of both control horns.

As a reference for installation, you can check the ailerons control horns that are pre-installed.

## Rudder Installation

- 1. The rudder is removable, and the hinges have been pre-installed for you at the factory.
- 2. Insert the steering rod into the ball link steering. Or if you prefer you can remove the tail gear and do the steering system later.



- 3. Partially insert the 1mm wire (hinge pin) into the hole on the top of the rudder as shown in the pictures above. Once the hinge pin has been started, line up the hinge halves in the rudder and the fuselage and slide the wire all the way through the hinges.
- 4. Secure the hinge pin with a piece of transparent tape on top of the rudder.

## RUDDER SERVO AND LINKAGE INSTALLATION

### Required for this section

#### Components

- Fuselage Assembly
- Rudder Servo
- 4-inch Double Servo Arm
- Wire Crimps (4)
- Pull-Pull Cable (2)
- Ball Link (4)
- 3mm x 15mm Socket Head Cap screw (4)
- 3mm Flat Washers (X8)
- 3mm Lock nut (X3)

#### Tools

- #1 Phillips Screwdriver
- 2.5mm Hex Driver
- 5.5mm Nut Driver
- Needle Nose Pliers
- Threaded or Shrink Tube

#### Adhesives/Building Materials

- Thin CA
- Thread Locker

1. Use a #1 Phillips screwdriver to thread a servo mounting screw into each of the pre-cut holes in the servo mounting rails in the rudder tray inside the fuselage. Remove the screw and apply a small amount of thin CA to each of the holes to harden the threads cut by the screw. Let the CA fully cure before moving forward.



2. Insert the rudder servo into the rudder tray inside the fuselage with the output shaft towards the tail of the airplane. Mount the servo to the tray using the screws provided with your servo.
3. Center the servo using your radio system. Install the 4-inch servo arm so that is perpendicular to the servo case. Apply a small drop of blue thread lock onto the servo arm screw and secure it in place. If you are using a servo arm with clamping screws, apply a drop of blue thread lock and secure them in place.

### Quique's Tip:

You may find that the servo arm for pull-pull does not fit close to perpendicular to the servo case. Since the Ultimate 70cc does not require a servo arm with an offset for pull-pull, try rotating the arm 180° to see if it fits closer to perpendicular when mounted in this orientation.



4. Locate the pull-pull cable exit holes in the rear of the fuselage. Use a hobby knife with a #11 blade to remove the covering from the hole. The plastic tube guide is located approximately 8 ¼-inches (210mm) from the rudder hinge line (see picture above). The tube should run perpendicular to the rudder hinge line. With the canopy removed and looking from the cockpit towards the tail you will see the nylon tube guides for the cables.



5. Using pliers, thread a rigging coupler approximately halfway into a ball link. Take a section of pull-pull cable and route it through a small piece of heat shrink tubing, followed by a cable crimp. Then route the cable through the rigging coupler and back through the crimp. For extra security, you can loop the cable around the crimp a final time. Slide the crimp tight against the coupler and use a crimping tool to permanently attach the cable. Apply a small amount of thin CA to aid in securing the cable and crimp. Once secure, slide the heat shrink tubing back over the cable and crimp, and shrink it in place. The shrink tubing is only used to keep the cables looking neat and prevent the wire from snagging on any objects. Repeat this process for the second cable.
6. Attach a ball link and rigging coupler assembly to each side of the rudder servo arm. The order of hardware is as follows:
- M3x15 Socket Head Cap Screw
  - M3 Washer
  - Ball Link (with rigging coupler)

- Servo Arm
- M3 Washer
- M3 Lock Nut

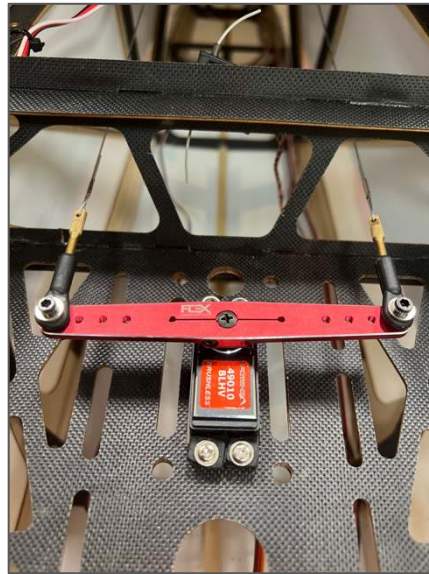

- 7. The correct hole locations are 2 inches (50.8mm) from the center of the servo arm. If you are using the recommended servo arm, these are the two outermost holes.
- 8. Route the pull-pull wire through the fuselage and out the exit holes located in step 4. Be sure to route the cables so that they do not tangle or cross. The cables should route straight from the servo arm to the exit of the fuselage.
- 9. Attach the ball link to the rudder control horn using a 2.5mm hex driver and a 5.5mm nut driver. Use the same order of hardware as used with the aileron control horns (page 14).
- 10. Power on your radio system and make sure the control horn is perpendicular to the servo case. Route a cable through a piece of heat shrink tubing, through a crimp and then through the rigging coupler mounted to the servo arm. Route the cable back through the crimp. For extra security, you can loop the cable around the crimp a final time. Repeat for the other pull-pull cable.



- 11. Pull the cables tight, while keeping the rudder centered. Once happy with the centering of the servo with the cables tight, use a crimping tool to permanently attach the crimp to the cables. Apply a small amount of thin CA to the cable and crimp joint for extra security. Once the CA has fully cured, slide the heat shrink over the joint and shrink it to secure it in place.
- 12. Adjust final cable tension by removing the ball links and by threading the rigging coupler further into the ball link. Start with the side that was only threaded one-third of the way into the link. Be sure to keep the rudder centered in the process. Do not over tighten the cables.

### Quique's Tip:

When new, pull-pull cables will stretch slightly in the first several flights. Adjust the tension as needed until the stretching stabilizes.

## MOUNTING THE STAB

### Required for this section

#### Components

- Carbon Fiber Horizontal Stabilizer Tube
- Left and Right Horizontal Stabilizers
- Fuselage Assembly
- M3x15 Socket Head Cap Screw (4)
- M3 Washer (4)
- Elevator Servo Extensions (2)

#### Tools

- Hobby Knife with a #11 blade
- #1 Phillips Screwdriver
- 2.5mm Hex Driver

#### Adhesives/Building Materials

- Thin CA
- Blue Thread Lock



1. Route the (2) 36-inch (910mm) elevator servo extensions through the holes in the corners of the formers to keep them from bouncing around inside the fuselage. Place the female end of the servo extension in the retention slot cutout at the exit of the fuselage. This will prevent the extension from falling back into the fuselage.
2. Insert the carbon fiber horizontal stab tube into the appropriate hole in the fuselage and approximately center it left and right. Slide the left horizontal stabilizer onto the carbon tube, connect the servo to the servo extensions and feed the servo wires into the fuselage.



3. Use a 2.5mm hex driver to secure (2) M3x15 socket head cap screws and (2) M3x12 flat washers to keep the horizontal stabilizers in place.
4. Repeat steps 2 and 3 for the right horizontal stabilizer.



## LANDING GEAR INSTALLATION

### Required for this section

#### Components

- Fuselage Assembly
- Wheel Pant (2, L & R)
- Main Wheel (2)
- M4x25 Socket Head Cap Screw (4)
- M4 Flat Washer (8)
- M4 Lock Nut (4)
- M3x15 Socket Head Cap Screw (4)
- M3 Flat Washer (4)
- Landing Gear Axle (2)
- M5 Lock Collar (4)

#### Tools

- 1.5mm Hex Driver
- 2.5mm Hex Driver
- 3mm Hex Driver
- 7mm Wrench
- 10mm Wrench
- 12mm Wrench
- Needle Nose Pliers (optional)

#### Adhesives/Building Materials

- Blue Thread Lock



1. Assemble the axle to the landing gear leg. Use one 5mm flat washer between the lock nut and the landing gear leg as shown above. Fully tighten using a 10mm and 12mm open end wrench.



2. Install the wheel on the axle, followed by the wheel collar orienting it in such a way that the side with the smaller diameter faces the wheel. Make sure the collar set screw lines up with the flat spot on the axle. Use blue thread lock on the set screw and tighten the set screw in the wheel collar. Ensure that the wheel spins freely after everything has been tightened.



3. Install the wheel pants using a 2.5mm hex driver, two M3x15 socket head cap screws and two M3 washers. Apply blue thread lock to the screws before securing them in place.

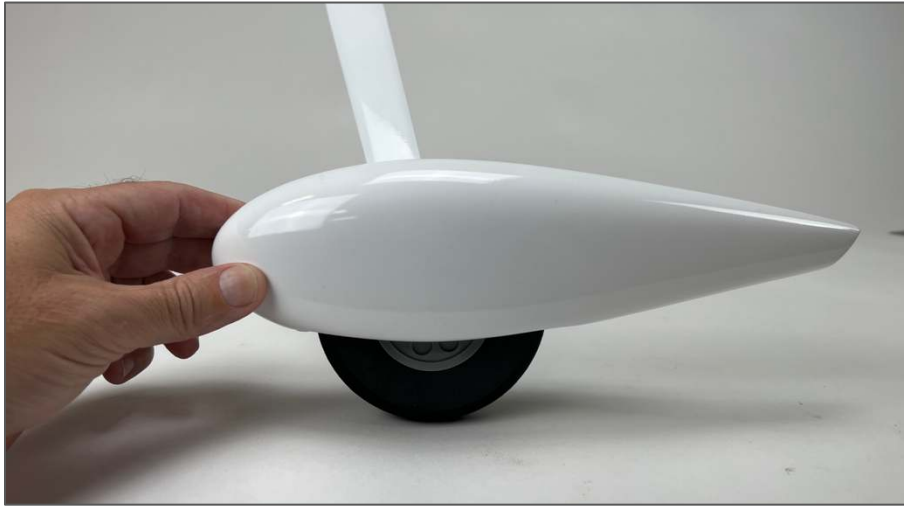

4. Be sure to note that the landing gear sweeps rearwards as it moves away from the fuselage. The wheel pant mounting holes are specific to a side.



5. With the fuselage inverted on your workspace, place the landing gear on the fuselage so that it sweeps backward as it moves away from the fuselage. Place an M4x25 socket head cap screw with an M4 washer through the landing gear and through the landing gear mount in the fuselage. Note that there are not threads in the aluminum angle mount in the fuselage. Place an M4 washer over the screw, followed by an M4 lock nut. You may need to use needle nose pliers to access the screws more easily from inside the fuselage. Tighten the screws using a 3mm hex driver and an 7mm open end wrench. Do not fully tighten until all four M4 screws are in place, and all the M4 lock nuts have been started.

# ENGINE AND THROTTLE SERVO INSTALLATION

The Ultimate 70cc is designed for a twin 70-76cc engine.

This manual covers the installation of the DA-70

## DA-70 ENGINE INSTALLATION

### Required for this section

#### Components

- Fuselage Assembly
- Engine
- Engine Standoffs (15mm)
- 1/4-20 Lock Nut (4)
- 1/4-20 x 1 1/2-inch Socket Head Screw (4)
- 1/4-inch flat washer (4)
- 1/4-inch fender washer (4)

#### Tools

- Drill
- 1/8-inch (3mm) Drill Bit
- 1/4-inch (6mm) Drill Bit
- 1/4-inch Hex Driver

#### Adhesives/Building Materials



1. Remove the plywood structure on the fuselage, just below the motor box and behind the throttle servo mounting location by pushing with your fingers. If this does not push out easily, you can trace the shape with a hobby knife and a sharp #11 blade to make it easier to remove. Regardless of the exhaust system used, this must be removed for proper cooling.

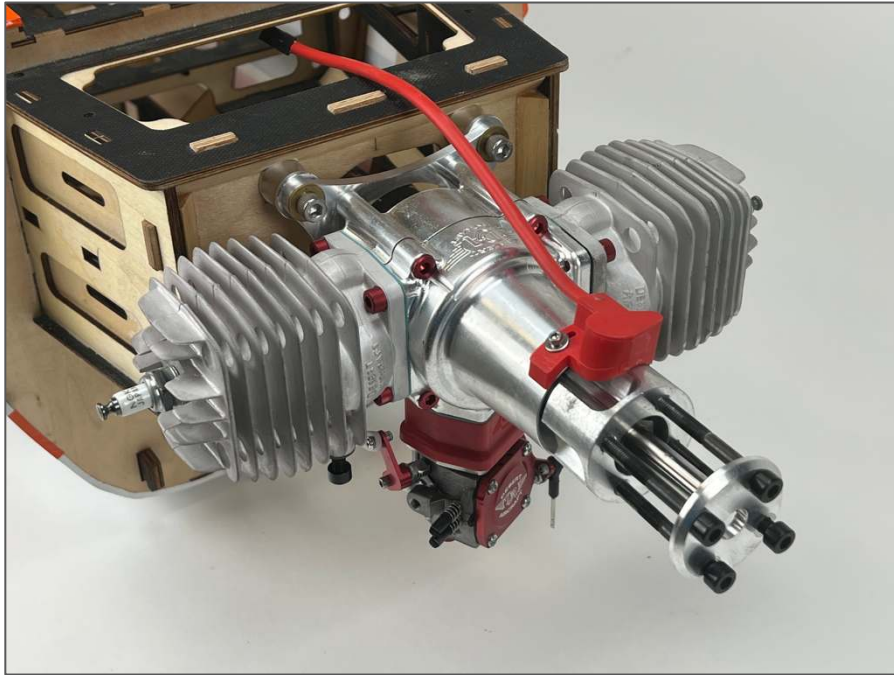

2. The engine mounting location for the DA-70 is laser-etched into the firewall for your convenience. If using a different mounting pattern, the “+” represents the engine crankshaft. Use a 1/8-inch drill bit and drill to create a pilot hole in the center of the four bolt hole etchings in the firewall. Use a 1/4-inch drill bit to enlarge these holes.
  
3. Mount the engine (without the exhaust) to the firewall using (4) 15mm engine standoffs, (4) 1/4-20 x 1 1/2-inch socket head cap screws, (4) 1/4-inch flat washers, (4) 1/4-inch fender washers and (4) 1/4-20 Lock Nuts. The order of components is as follows:
  - 1/4-20 x 1 1/2-inch Socket Head Cap Screw
  - 1/4-inch flat washer
  - Engine
  - 15mm Engine Standoffs
  - Firewall
  - Fender washer
  - Lock nut

## DA-70 Throttle Servo and Throttle Linkage Installation

### Required for this section

#### Components

- Fuselage Assembly
- Throttle Servo
- 24-inch (600mm) Servo Extension
- Safety Servo Clip Connector
- 2mm White Ball Link
- M2x10 Phillips Head Screw (1)
- M2 Flat Washer (2)
- M2 Lock Nut (1)

#### Tools

- #1 Phillips Screwdriver
- 2.5mm Hex Driver

#### Adhesives/Building Materials

- Thin CA
- Blue Thread Lock

1. Attach the 24-inch (600mm) servo extension to the throttle servo. Use a Servo Connector Safety Clip (FPZA1040), thread or heat shrink tubing to secure the extension in place.

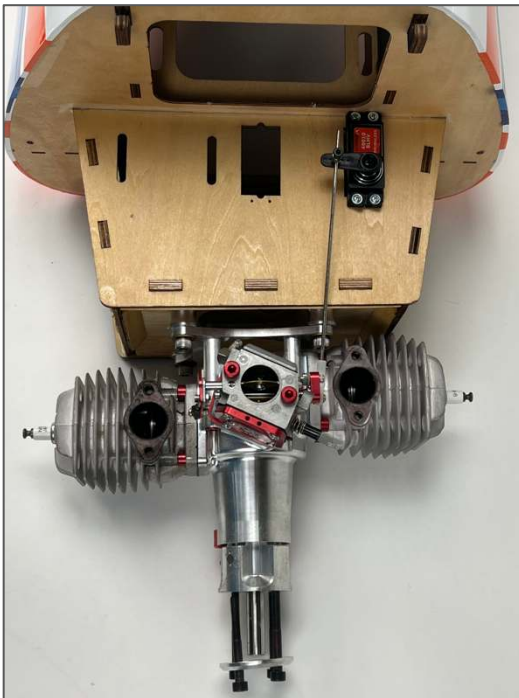

2. There are two options for the servo tray. The middle location is normally used when stock mufflers are used. The one to the side of the motor box is used when canisters are used. Install the throttle servo with the output shaft towards the nose of the aircraft.
3. Use the radio system to center the servo, then install a 1-inch (25mm) servo arm onto the servo. If you used the middle location, make sure the servo arm is oriented to the side of the fuselage that provides the straightest geometry to the throttle arm on the engine. If a canister is used, orient the servo arm towards the centerline of the fuselage to provides the straightest geometry to the throttle arm on the engine. Do not secure the servo arm screw yet.

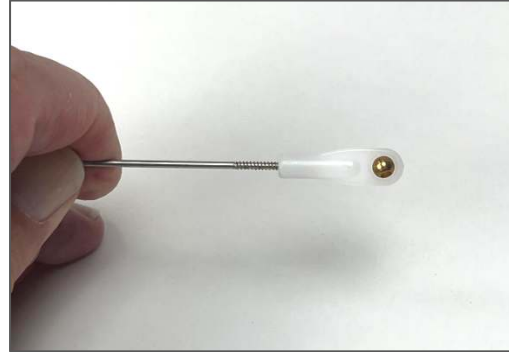

- 4. Secure the quick connector to your servo arm. Be sure to use blue thread lock for a secure attachment. The order of components is as follows:
  - Quick connect housing
  - Washer
  - Servo Arm
  - Washer
  - Nut
- 5. Locate the pushrod that is only threaded at one end. Thread this linkage approximately halfway into a WHITE ball linkage. Secure the ball link to your engine throttle arm using the 2 x 10mm screw, 2mm washers (2), and 2mm lock nut. Do not use thread lock on these parts, as it can weaken the plastic insert in the lock nut. The order of these components should be:
  - Screw
  - Washer
  - Throttle Arm
  - Washer
  - Lock Nut
- 6. Remove the M3x5 socket head cap screw from the quick connect. Insert the non-threaded portion of the throttle linkage through the hole in the side of the quick connect. With the radio powered on, center the throttle servo and engine throttle arm. Use blue thread lock and secure the M3x6 screw onto the linkage. Check throttle movement and position relative to stick position and make any changes necessary. Fully tighten the screw.

### Quique's Tips:

- Use the shortest servo arm possible while still getting full throttle arm movement on your engine. Your throttle end points should be around 110-120% when finished with the installation. A faster servo (like the Potenza DS49010HV) with a shorter arm is preferred over a slower servo with a longer arm.
- For the most linear throttle response, adjust the throttle linkage length to balance the end points for your throttle servo. You do NOT want your end points to be mismatched (example: 60/120). Get your end points as close to one another as possible (example: 114/116) for the most linear throttle response.

## IGNITION INSTALLATION

### Required for this section

#### Components

- Fuselage Assembly
- Ignition
- Ignition Switch
- Ignition Battery
- Regulator (if applicable)

#### Tools

- Hobby Knife w/#11 Blade
- #1 Phillips Screwdriver

#### Adhesives/Building Materials

- Hook and Loop Strap (2)
- Adhesive-Back Hook and Loop Tape

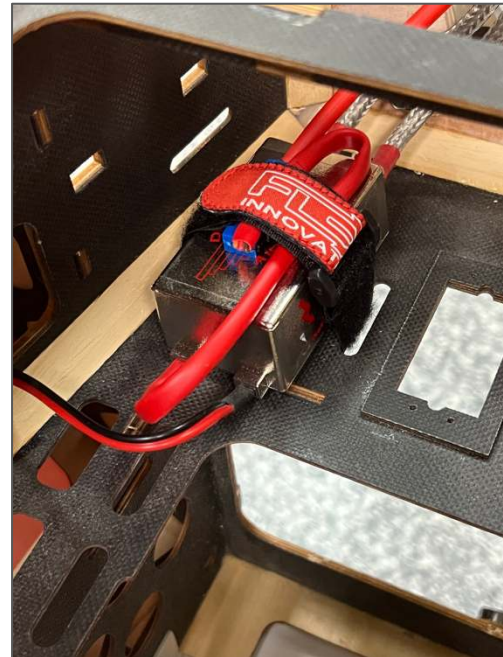

1. Locate the ignition switch hole towards the nose of the fuselage. Note that there are switch locations on both sides of the fuselage for your preference. Use a hobby knife with a #11 blade to remove the covering from the hole of your choice. Test fit your switch and modify the hole if needed. Secure it in place using the screws included with your switch. If your switch mounting screws thread into metal, be sure to apply blue thread lock. DO NOT apply blue thread lock if they thread into plastic.
2. The ignition can be mounted wherever you prefer. We have found that with the DA-70 the above depicted location works well. There are many ways to install an ignition and we recommend you mount it per your engine manufacturer's instructions.
3. Pass the hook and loop strap through the slots in the motor box and secure the ignition as box show in the picture above.



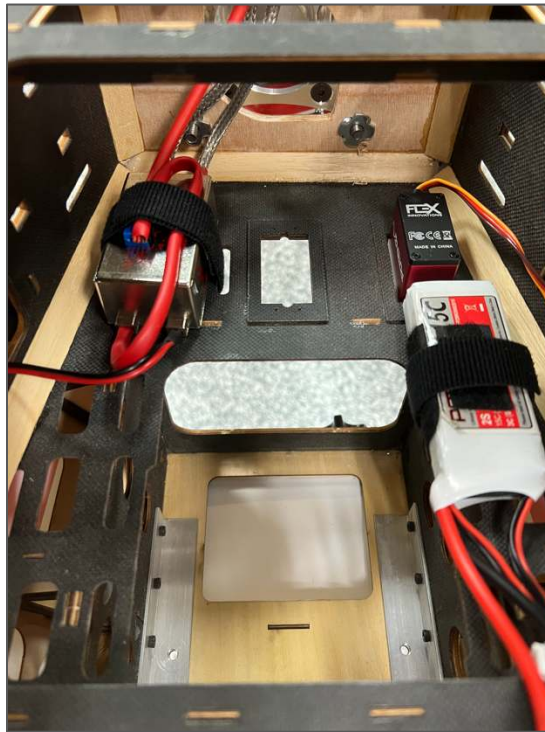

- 4. Place your ignition battery inside the fuselage as shown in the above picture. Use adhesive-backed hook and loop tape between the battery and the fuselage and secure the battery with a hook and loop strap.
- 5. Route all your wiring and make all electronic connections at this time. Secure any permanent connections with Servo Safety Clips (FPZA1040). Be sure to secure the wiring so that it will not bounce around in the aircraft. Also, be sure to secure the wiring in a way the wires will not chafe over time from vibration. A typical ignition setup will be connected as follows:

**Ignition Battery → Ignition Switch → Ignition Regulator → Ignition → Engine**

## FUEL TANK INSTALLATION

### Required for this section

#### Components

- Fuselage Assembly
- Fuel Tank
- Fuel Line

#### Tools

- Pliers

#### Adhesives/Building Materials

- Hook and Loop Strap (2)
- Adhesive-Back Hook and Loop Tape

The Flex Innovations Lightweight 24oz Fuel Tank is included with your Ultimate 70cc. Before installing the fuel tank check all fittings are properly installed and that the clunk line inside the tank is appropriately sized.

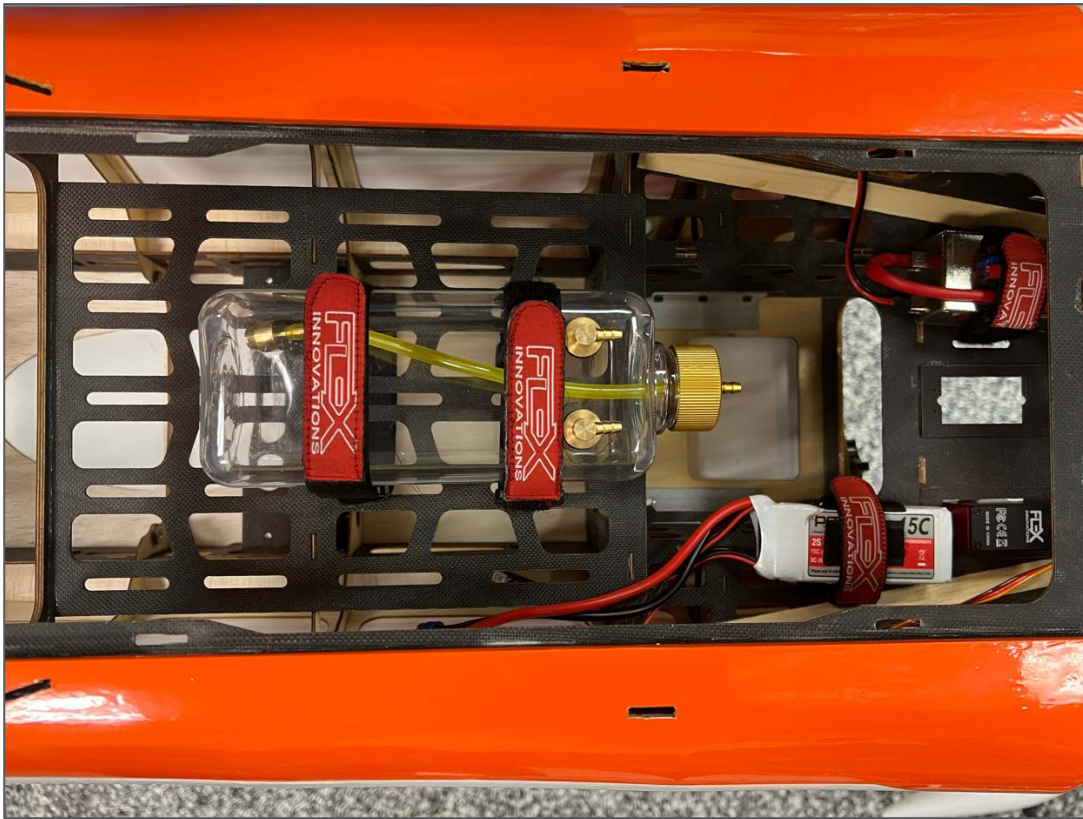

- 1. The fuel tank tray has plenty of room for your fuel tank. If you are using a single tank, you can place the fuel tank in the middle of the tray as shown in the image above. If you plan on using a smoke system, two of the 24oz Lightweight Fuel/Smoke tanks (FPM2019) should be used, installed side by side. One is included in your kit.

Apply adhesive-backed hook and loop tape to the bottom of your tank(s) and to the fuel tank tray. Place the tank(s) in their location and secure them with two hook and loop straps. These straps should be snug but not overly tight, as the fuel tanks are very lightweight and can be easily crushed. The hook and loop tape on the bottom of the tank(s) will prevent the tank from moving fore and aft, and the hook and loop straps will prevent the tank from pulling away from the tray.

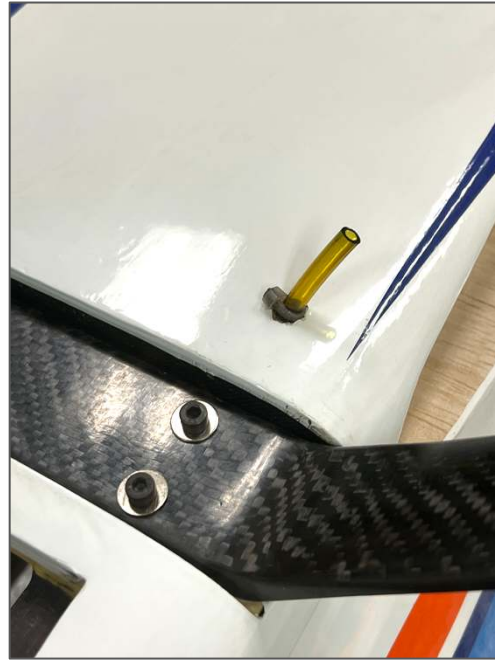

2. After the tank is in position, route and trim your fuel lines appropriately. Your clunk line should go to the carburetor or throttle body. The fill line should go to your fuel dot or filling system. We recommend the McFueller Fuel Dot (FPMAMCFUELER). The vent line should wrap around the back of the tank(s) and pass back in front of the tank(s). It should then exit the bottom of the fuselage as shown in the image above. After the vent line exits the fuselage, use a cable tie around the fuel line to prevent it from slipping back into the fuselage. Don't over-tighten the cable tie, as air and fuel will need to vent from this line. Be sure to keep your fuel line away from components that get hot (like your exhaust or cylinder heads) and route it in such a way that it will not bounce around or chafe on any of the interior structure of the fuselage.

## EXHAUST AND COWLING INSTALLATION

### Required for this section

#### Components

- Fuselage Assembly
- Cowling
- Cowling Baffles
- Muffler (or Canisters/Headers)
- Exhaust Gasket (2)
- M2.5 x 4 Wood Screw
- Motor Box Cover Plate
- M3 x 20 socket head cap screws (2)
- M3 Flat Washer (6)
- M3 x 10mm socket head cap screws (8)
- O-Rings (8)
- Canister mount plate
- Silicone tubes
- M3 x 15 Socket Head Cap Screw (4)

#### Tools

- 2.5mm Hex Driver
- #1 Phillips Screwdriver
- Rotary Tool
- Rotary Tool Sanding Drum
- Felt-Tipped Pen

#### Adhesives/Building Materials

- Colored Silicone (Red typically preferred)
- Thin CA
- Medium CA
- CA Accelerator
- Blue Thread Lock
- 30 Min Epoxy
- Micro-balloons
- Mixing Cups
- Mixing Sticks
- Paper Towels

If you plan to use stock mufflers, please follow the instructions (A) below. If you plan on using canisters, please follow canister instructions (B) on the following pages. Be sure to follow the engine baffling instructions for both setups.

### Muffler Installation (A)

- 1A. Install the manual choke linkage using your preferred method. You could use a 2mm ball link and 2mm linkage found on many 60-class ARF or ARFSV aircraft. We leave the pushrod long until the cowling is installed and then trim it for the proper length.
- 2A. Install the muffler on the engine using the hardware provided with your engine. Follow your engine manufacturer's installation instructions. Typically, most engines will use a gasket between the muffler and cylinder and the socket head cap screws will pass through a lock washer before securing the muffler to the cylinder.



- 3A. Every engine and muffler choice will require different openings in the cowling. The picture above shows a DA-70 with DA mufflers. Other engine brands and other mufflers will require different cut outs. Use a rotary tool with a sanding drum to cut the holes. Test fit the cowling to be sure there is adequate gap between the muffler and cowling. We recommend at least 1/8-inch (3mm) gap. Note the elongated hole are needed to allow the cowling to move forward to clear the baffles when installing or removing the cowling. Once baffles are clear the front of the cowling can be moved down and be removed. Other holes shown in the cowling are for choke, needle adjustment and needle viewer.



- 4A. For the fuselage exit hole, use a hobby knife with a #11 blade to open the rectangular hole in the bottom front of the fuselage as well as the two half oval holes towards the bottom middle of the fuselage. Be sure to leave about 1/8-inch (3mm) overlap so that you can iron the covering to the sheeting on the inside of the fuselage. You may need to cut a few slits in the edge of the covering due to the curved shape of the holes. Apply some epoxy to the edges of the covering to help prevent oil and debris from getting under the covering.

## Canister Installation (B)

Recommended canister and headers for the different engines are listed in the front section of the manual.



- 1B. Install the exhaust on the engine using the hardware provided with your engine. Follow your engine manufacturer's installation instructions. Typically, most engines will use a

gasket between the muffler and cylinder and the socket head cap screws will pass through a lock washer before securing the muffler to the cylinder.



- 2B. Install the 4-silicone tubes into the canister mount plate. Place the mount plate in the location shown in the image above. Install the header and canister per your engine and exhaust manufacturer's instructions, placing the exhaust through the mount. Once the exhaust is mounted to the engine, install the (4) M3 x 15 Socket Head Cap Screw with flat washers to secure the canister mount in place. Use Blue Thread Lock.

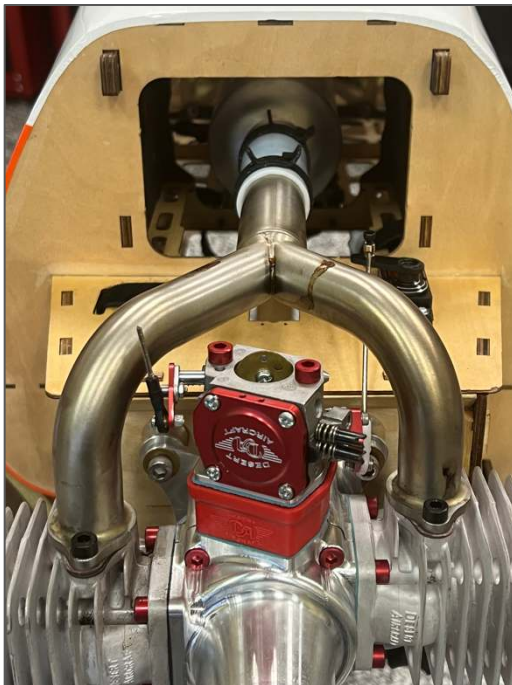

- 3B. The images above show the typical DA-70 with a 2 to 1 header for a single canister.



- 4B. Every engine and exhaust choice will require different openings in the cowling. The images above show a DA-70 with 2 to 1 header install. This show that headers stay inside the cowling and no additional opening is required.

### Baffle and Final Cowling Installation



- 1. Locate the engine baffles. These are designed to fit the DA-70 The baffles are labeled according to their locations. **The lettering should face the outside of the baffles when assembled.**





- 2. You can start with the left of right-side baffle. In this case we will start with the right baffle. Using thin CA, glue the "Right Bottom" to the "Right Outside" and to the "Right Inside". All the marking stays to the outside of the baffle. It is important to glue them square.

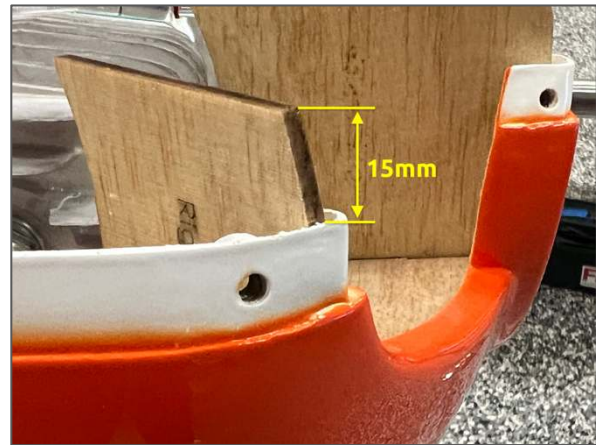
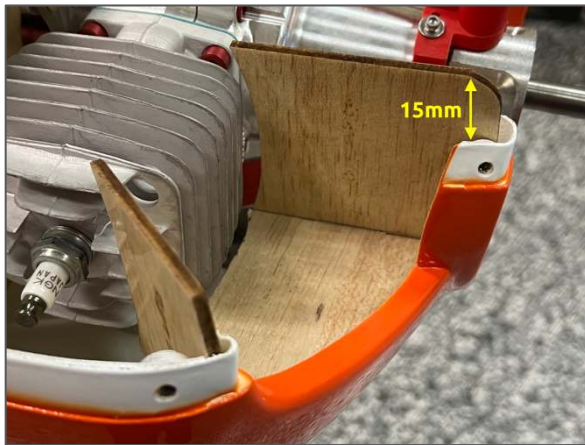

- 3. Mark 15mm as shown in the pictures.

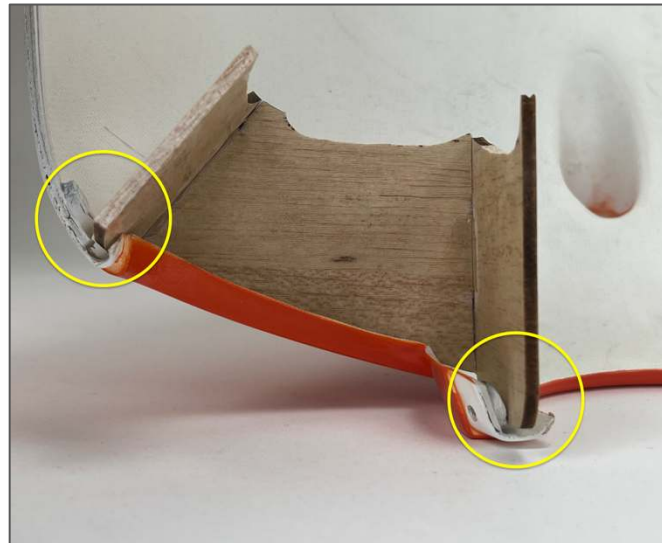
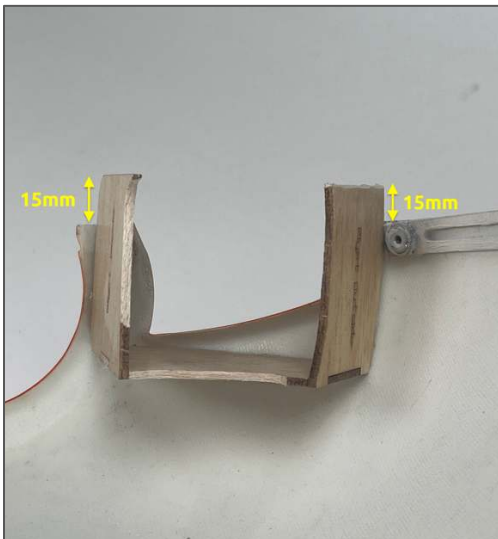

- 4. Place the baffle in the right side of the cowling intake. The baffle would seat in the inlet curved areas as circle in the picture. Also consider the 15mm mark to adjust the height and assure it is level. Once you are happy you can tack lightly with thin CA.

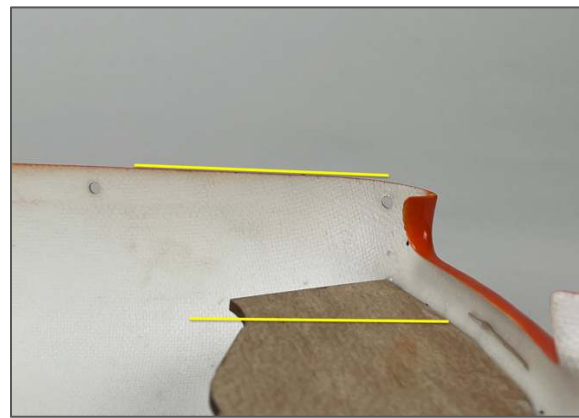
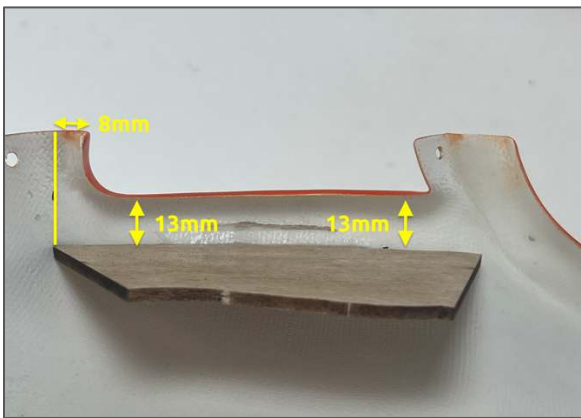

- 5. For the top cowling halve, using thin CA, tack the “Right Top” baffle to the right side of the top cowling air inlet as shown in the picture above. The baffle should be parallel to the cowling edge as shown by the two lines in the picture above right. Verify the fit of the entire assembly by installing the bottom cowling halve to the fuselage and the top cowling halve to the both the bottom cowling and the fuselage. Now is a good time to see if anything needs to be trimmed or adjusted to fit. Once you are happy, you can apply some medium CA to secure the baffle to the cowling.
- 6. Repeat the same procedure for the left side baffle.
- 7. Once you are happy with the overall fit mix some 30minutes epoxy with micro balloons and apply to the joint area between the cowling and baffle. Apply more mixed glue to fill larger gaps.
- 8. Once assembled and the epoxy has fully cured, you can paint the baffles with enamel-based paint to help with appearance and help resist damage from fuel or oil. There may be some final tuning required. If you are using a different engine, you can use these as a template or modify them as necessary.

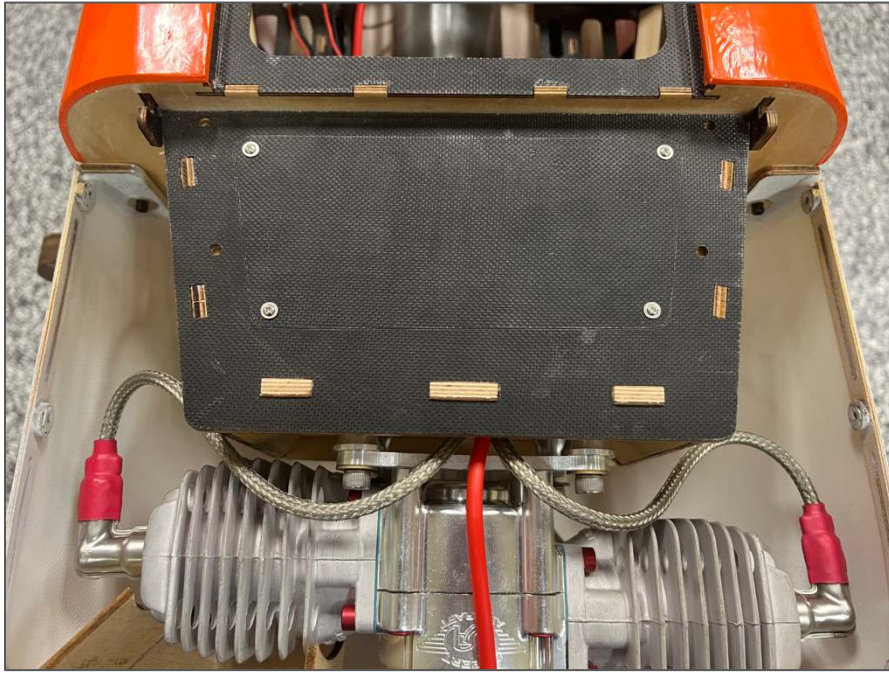

- 9. Locate the motor box top plate and the (4) M2.5 x 8mm wood screws. Use a #1 Phillips screwdriver to thread an M2.5 x 8mm screw into each of the pre-cut holes in the motor box for the top plate. Remove the screw and apply a small amount of thin CA to each of the holes to harden the threads cut by the screw. Let the CA fully cure before proceeding.
- 10. Secure the top plate in place using a #1 Phillips screwdriver.
- 11. Before installing the cowling, verify that all spark-plug wires, fuel lines and any battery or servo wires are correctly installed and well-secured.
- 12. Once you are happy with the fit of your cowling, proceed to installing the cowl. Use a 2.5mm hex driver, (2) M3 x 20 socket head cap screws and (2) M4 flat washers to secure it in place. The two screws are installed from the inside of the cowling near the top bottom half cowling.
- 13. Installing the top half of the cowling using the (8) Hex head M3 x 10mm screw with (8) rubber O-rings.



- 14. Install your propeller and spinner. For the DA-70, we recommend a Flex 24x9 carbon fiber propeller and the Ultimate 70cc orange carbon fiber spinner.

## ELECTRIC POWER SETUP

The Ultimate 70cc was designed for electric power as well.

Flight time with the recommended equipment is around 4 to 5 minutes with proper throttle management, leaving you with good reserve.

For your first flights on the recommended setup, set your timer for 3 minutes and check the remaining capacity when charging your batteries. Adjust the timer according to your personal flight style.

Recommended Electric Power System:

- Potenza 65cc 185kV Motor (FPZM65CC)
- (4) 2.5 in (63mm) motor standoffs
- Potenza 6S 6200mAh 40C batteries (two in series for 12S)
- Castle Edge 160HV ESC
- Mejlzik 25 x 12S Propeller

## MOTOR INSTALLATION

### Required for this section

#### Components

- Fuselage Assembly
- Motor
- M5x15 Socket Head Cap Screw (4)
- M5 Flat Washer (4)
- ¼ x ¾ Socket Head Cap screw (4)
- ¼ Flat Washer (4)
- 2 ½ in (63mm) Standoff (4)
- M5x15 Socket Head Cap Screw (4)
- M5 Flat Washer (4)

#### Tools

- 2mm Hex Driver
- #1 Phillips Screwdriver
- Drill
- 3mm Drill bit
- 5mm Drill bit

#### Adhesives/Building Materials

- Blue Thread Lock

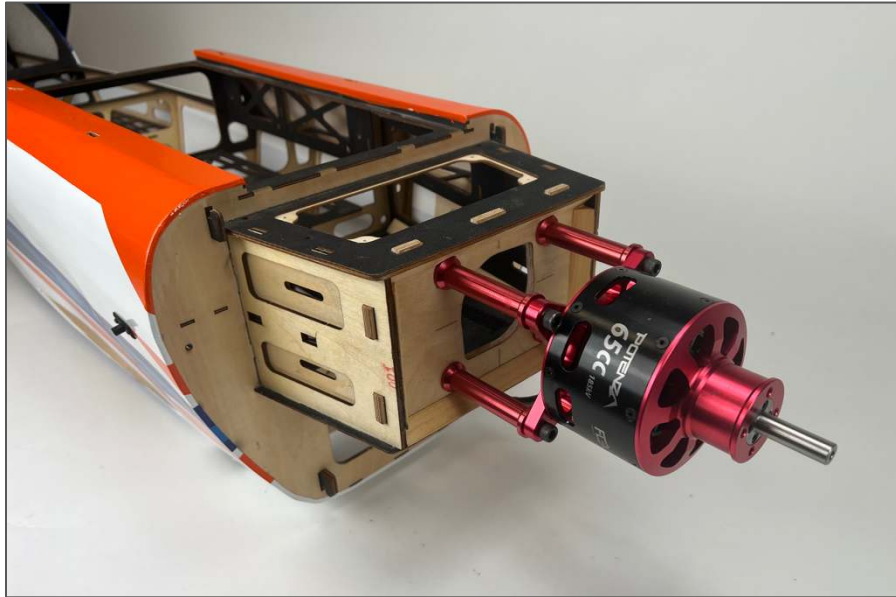

- 1. The Potenza 65cc motor has the same bolt pattern as the DA70cc. Starting with a 3mm drill bit, drill the 4 pilot holes at the marked locations on the motor box. Enlarge the holes using the 5mm drill bit.
- 2. The 63mm motor standoffs used are threaded for ¼ -20 bolts on the motor side and 5mm bolts on the firewall side.
- 3. Use (4) ¼ x ¾-inch socket head cap screws and (4) ¼-inch washers to mount the motor. Be sure to apply blue thread lock when securing them.
- 4. Install the motor to the firewall using (4) M5 x 10 socket head cap screws with (4) M5 washers. Be sure to use blue thread lock when securing them.

## ESC INSTALLATION

### Required for this section

#### Components

- Fuselage Assembly
- ESC
- M2x12 Phillips Head Self-Tapping Screws (4)

#### Tools

- #1 Phillips Screwdriver
- Drill
- 1.5mm Drill Bit

#### Adhesives/Building Materials

- Thin CA



- 1. Mount the ESC on the bottom of the motor box as shown in the picture above. This is a great location for cooling. Mark the mounting hole locations and use a 1.5mm drill bit to drill holes in the motor box. Using a #1 Phillips Screwdriver, thread an M2 x 12 Phillips-head self-tapping screw into each of the holes. Remove the screw. Use thin CA to harden the threads, and once the CA has fully cured, you can install your ESC.
- 2. Tidy up and secure all the wiring.

## BATTERY TRAY INSTALLATION

### Required for this section

#### Components

- Fuselage Assembly
- Sticky Velcro
- Flex Innovations Battery Hook and Loop Strap Medium 300mm Long (4). FPMA1016

#### Tools

#### Adhesives/Building Materials

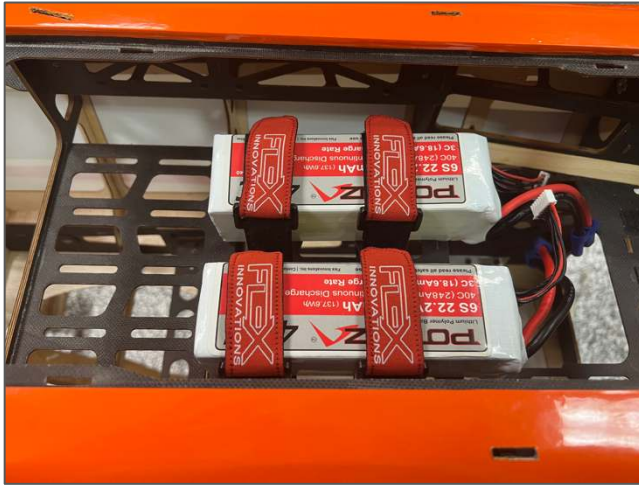

1. Apply adhesive-backed hook and loop tape to the tray. With the recommended electric set-up, the batteries should be placed roughly in the location shown in the pictures above.
2. Install four 300mm (11-3/4 inch) Flex Innovations Hook and Loop straps through the slots in the battery tray to secure the electric flight batteries. There are several slots to choose from, select the slots that work with your battery location

**Quique's Tip:**

- The battery location can be significantly different if other components are used, such as motor, ESC, battery, prop, spinner etc. Note: RX battery placement can be used to adjust the CG. The Ultimate has multiple trays, from nose to cockpit, to choose from for mounting the RX battery.

## MOTOR/ESC COOLING



1. When using the electric power setup, we recommend that you do not use the provided baffles for gas engines. The front openings provide enough cooling for the electric motor



and ESC. For cooling air exhaust, open the hole in the bottom of the fuselage just behind the landing gear mount.

## CENTER WING CABANE INSTALLATION

### Required for this section

#### Components

- Fuselage Assembly
- Vertical Struts (4)
- Diagonal Struts (2)
- Central Rib
- M3 x 15mm Screws (8)
- M3 Washers (4)
- M4 x 20mm Socket Head Bolts (2)
- M4 Washers (4)
- M4 Lock Nuts (2)

#### Tools

- 2.5mm Hex Driver
- 3mm Hex Driver
- 7mm Open Wrench

#### Adhesives/Building Materials

- Blue Thread Lock

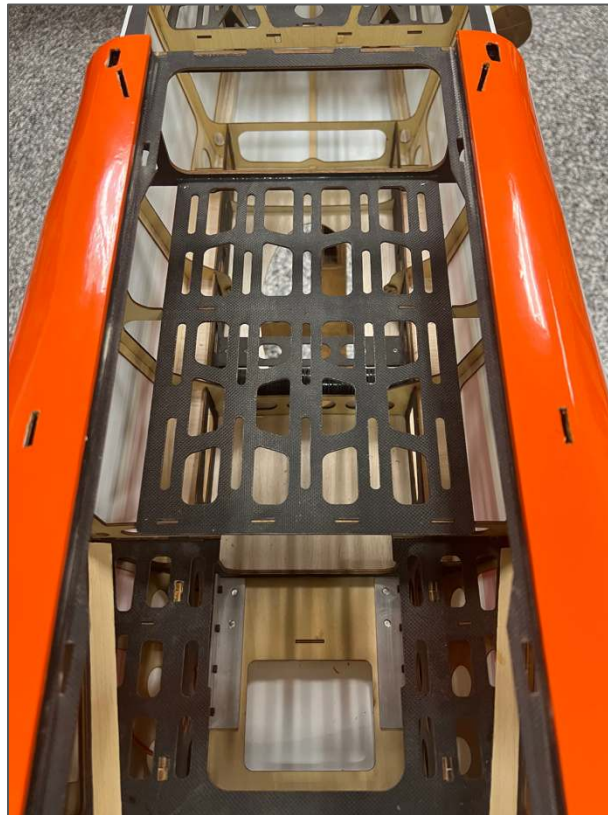

1. Locate the six holes in the fuselage for the center cabane struts. Remove the covering from these holes using a hobby knife with a sharp #11 blade.



- 2. Locate the 4 vertical struts. The front and rear vertical struts are identical. Take two vertical struts and loosely bolt them to the central rib. Use the following assembly sequence:
- M4 x 20mm Socket Head Bolt
  - M4 flat washer
  - Vertical strut
  - Central rib
  - Vertical strut
  - 4mm flat washer
  - Lock nut



3. Locate the two diagonal struts. The diagonal struts are mounted over the rear vertical struts as shown in the picture above. Slide the two vertical struts thru the rear most fuselage slots. Then proceed to install each diagonal strut thru each fuselage slot next to the rear vertical strut. Note that the diagonal strut has one end that is square and the other end round. As picture shows the square end goes on top of the vertical rear strut. Loosely mount using M3 x 15mm Screw (2) and M3 flat washer (2) to the pre-installed 3mm blind nuts. Apply blue thread lock to each screw.



4. Locate the 2 front vertical struts. Mount them using M3 x 15mm Screw (2) and M3 flat washer (2) to the pre-installed 3mm blind nuts. Apply blue thread lock to each screw.



5. The two vertical struts and the two diagonal struts are mounted to the central rib. Use this assembly sequence:
- M4 x 20mm Socket Head Bolt
  - M4 flat washer
  - Diagonal Strut
  - Vertical strut
  - Central rib
  - Vertical strut
  - Diagonal strut
  - M4 flat washer
  - M4 Lock nut



6. Return to all the bolts and tighten any that have not been tightened. Once fully assembled it should look like the picture above.

## BOTTOM WING TAB MOUNTS ASSEMBLY

### Required for this section

#### Components

- Fuselage Assembly
- Wing Tab Mounts (2)
- M3 x 15mm Screws (4)
- M3 Washers (4)

#### Tools

- 2.5mm Hex Driver

#### Adhesives/Building Materials

- Blue Thread Lock



1. Locate the wing tabs. Both tabs are identical so they can be mounted on either the right or left side of the fuselage.
2. Use M3 x 15mm Screw (4) and M3 washer (4) to mount the tabs on the lower bridge into the pre-installed 3mm blind nuts. Apply blue thread lock to each screw.

# FINAL ASSEMBLY

## RADIO INSTALLATION

### Required for this section

#### Components

- Fuselage Assembly
- Receiver
- Receiver Switch
- Aura 8 Professional (Optional)
- Receiver Batteries
- Hook and Loop Straps
- Adhesive-Backed Hook and Loop Tape
- Tie-Wraps

#### Tools

- #1 Phillips Screwdriver
- Hobby Knife with #11 Blade
- 2mm Hex Driver

#### Adhesives/Building Materials

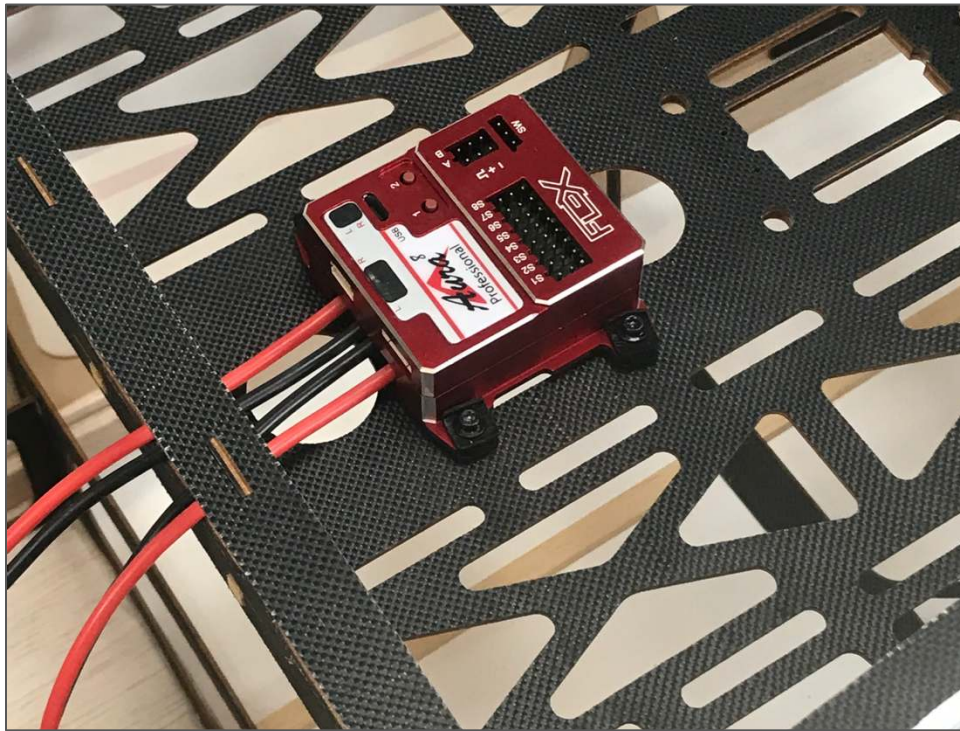

1. If you are using the Aura 8 Professional AFCS, it should be mounted forward of the rudder servo location in the center of the fuselage as shown in picture above.
2. Use a #1 Phillips screwdriver to thread an Aura mounting screw into each of the pre-cut holes in the mounting tray. Remove the screw and apply a small amount of thin CA to each of the holes to harden the threads cut by the screw. Let the CA fully cure before mounting the Aura and securing the (4) screws.



- 3. Locate the RX/Aura switch just under the canopy. Note that there are switch locations on both sides of the fuselage. Remove the covering from the hole of your choice using a hobby knife with a #11 blade and install your RX switch. Use blue thread lock if your switch uses screws with metal-to-metal contact. DO NOT use thread lock if your screws thread into plastic!

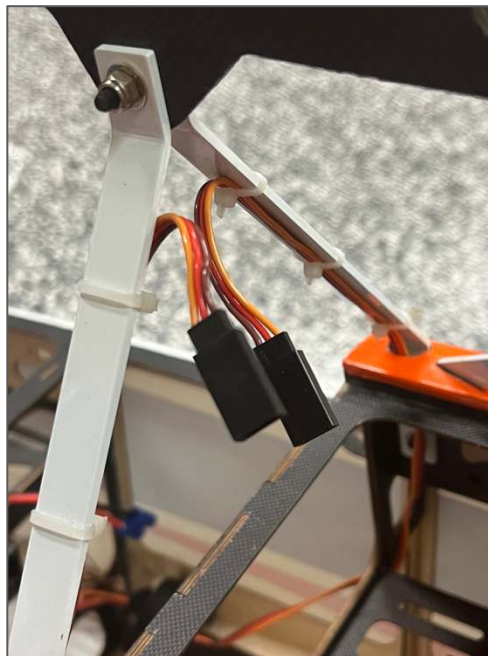

- 4. Route two 28in (710mm) heavy duty servo extensions up the rear cabane strut, and out the top wing. Secure the extension to the cabane struts using tie-wraps.

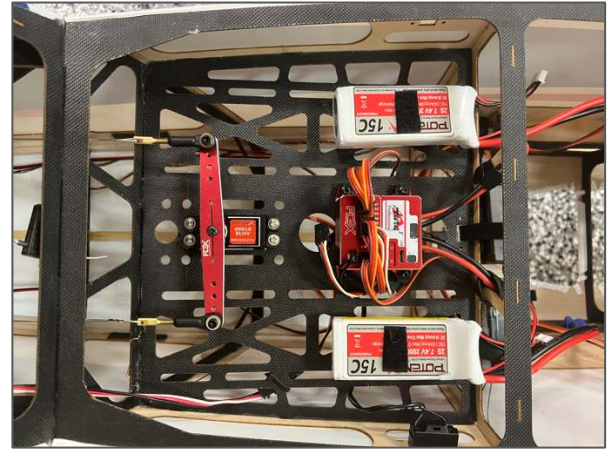

- 5. Make all the servo connections. Depending on balance (read CG section), install your (2) recommended batteries in one of the 3 tray the Ultimate has. Secure them using hook and loops straps. If you are using Aura 8 Pro your final installation would look like the picture. Note the RX it is not show in picture as in this case the photographed sample is using dual Futaba RX's. The RX's are in the belly and turtle deck of the airplane for maximum RF strength.
- 6. If you are not flying Aura, then place your single RX in the area where the Aura 8 Pro is in the picture.

## FIELD ASSEMBLY

### Required for this section

#### Components

- Fuselage Assembly
- Fuselage Hatches (2)
- Wing Panels (4)
- Wing Tubes (2)
- Wing Anti-rotation Pins (2)
- Interplane Struts (2)
- Retaining Pins M3 x 130mm (4)
- 4mm x 15mm Socket Head Cap Screws (4)
- M4 Washers (4)

#### Tools

- 3mm Hex Driver

#### Adhesives/Building Materials





1. Remove the rear Canopy and front hatch from the fuselage. Slide a wing tube into one of the lower wing panels. Partially slide the wing tube and wing into the lower wing tube socket. Be sure there are no bolts in the wing bolt location. Secure the aileron servo lead to the servo extension, and fully slide the wing into place, being sure not to pinch any wiring between the wing and fuselage. Secure the wing with an 4mm x 15mm socket head cap screw and M4 washer. Repeat for the other lower wing.



2. Locate one of the wing struts, note the side it will be installed in. Install the strut in the lower wing using the 3mm x150mm pin. Slide the top wing tube in the central rib socket with the tube sticking out 3 -4 inches to the side of the airplane where the strut is installed. Slide the appropriate top wing into the wing tube till the wing seats against the central rib. Install the top pin to the cabane.  
This procedure will support the top wing firm in place until the airplane is fully assembled.
3. Push in the wing tube until it is completely seated in the installed wing.



- 4. Install the two carbon-fiber anti-rotation wing pins. Push in each pin until they are completely seated.



- 5. Slide the remaining top wing panel into the wing tube and anti-rotation pins until the two top wing panels meet and show no gap. Secure the wings with two M4 x 15mm socket head cap screw two M4 washer.
- 6. Install the remaining wing strut using the two remaining 3mm x150mm wing strut pins.



- 7. Note that the struts are directional and will only fit one way. Push the straight end of the wire through the strut and through the wing strut block until the angled portion of the wire is flush with the strut. Repeat for both top and bottom sides of each strut.
- 8. Re-install the front hatch and canopy.

### Quique's Tip:

Using medium CA, glue the (4) M4 flat washers to the (4) M4 x 15 socket head cap screws. This will assist in the assembly of the model.



## DECAL INSTALLATION

A traditional set of clear decals is provided with the Ultimate 70cc.

However, if you want the very best finished appearance, we recommend the Premium Vinyl Graphics Kit made by Callie Graphics and sold by Flex Innovations. The part numbers are listed in the optional parts table.

Use the drawings provided below for a guide to apply decals to your model.

- 1. Thoroughly clean the model to ensure it is free of oil, fingerprints, and dust.
- 2. Separate the decals, but do not remove the paper backing.
- 3. Prepare a dishpan or small bucket with a mixture of warm water and liquid dish detergent. The ratio should be approximately one teaspoon per gallon of water.

- 4. Submerge the decal into the water/soap mixture and gently remove the paper backing. Removing the backing under water prevents fingerprints from being visible on the back side of the decal
- 5. Apply some water/soap mixture with your palm to the area desired. Once the area is saturated, position the sticker on the airplane. Even though these are not water transfer decals, using wet application methods allows the sticker to be repositioned, reduces bubbles, and eliminates fingerprints and other blemishes from being visible.
- 6. Hold the decal in place and use a paper towel to gently wipe most of the water away.
- 7. Use a soft piece of balsa or similar to squeegee out the remaining liquid from underneath the decal.
- 8. Repeat the process until all decals are applied. Do not move, or otherwise touch the model for at least 24 hours to allow adequate time for the remaining water to evaporate.

### Ultimate 70cc Orange Scheme

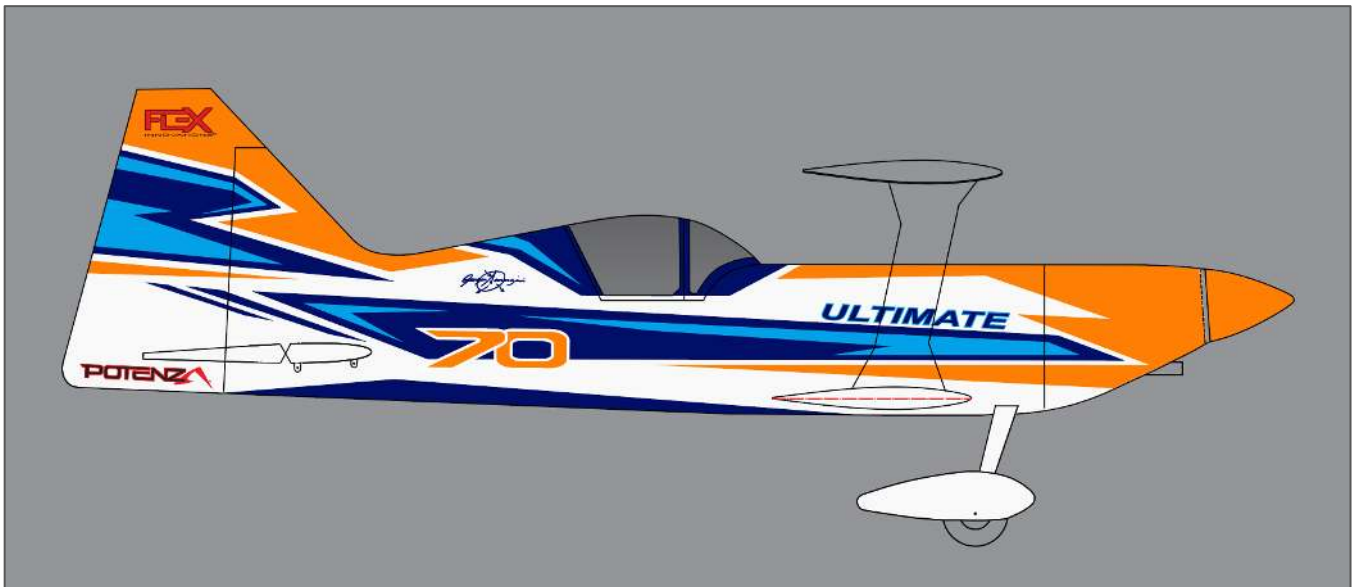

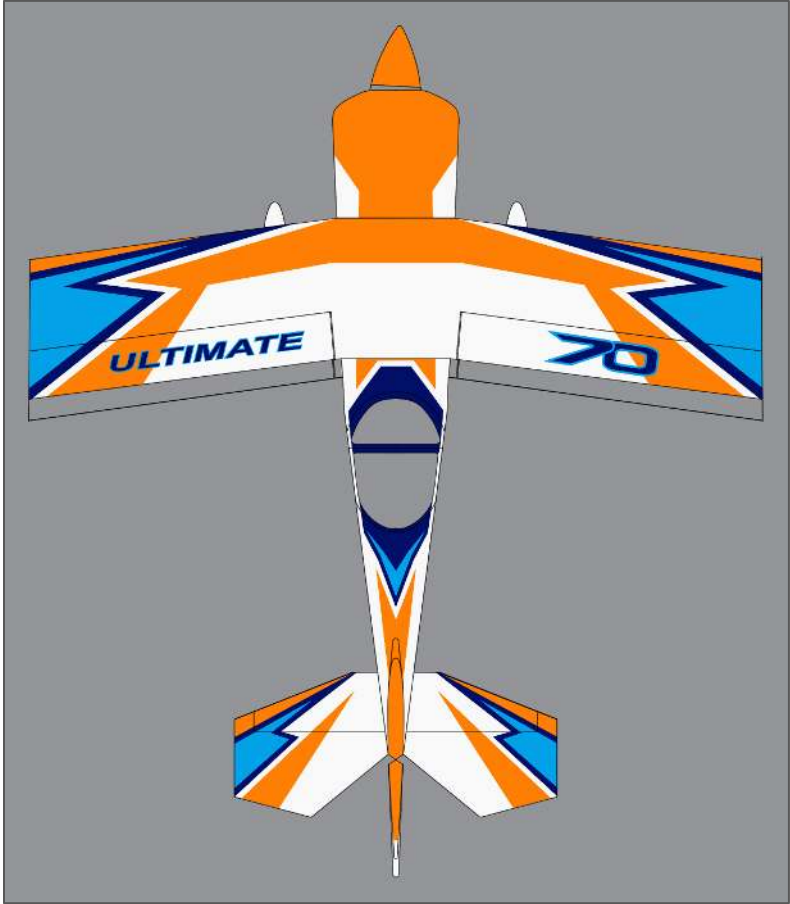
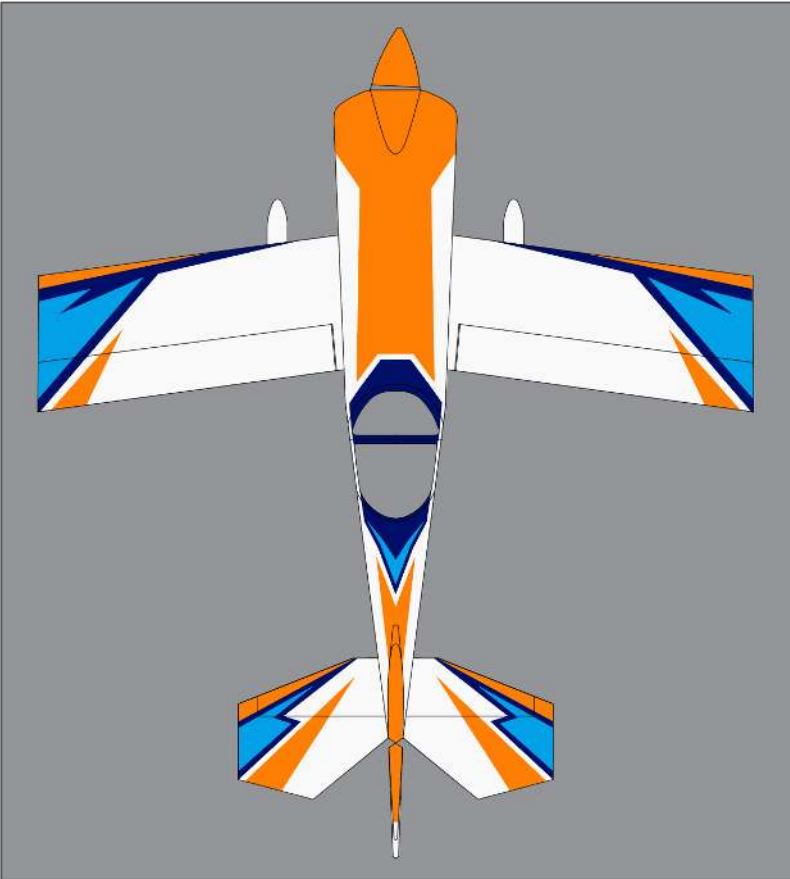

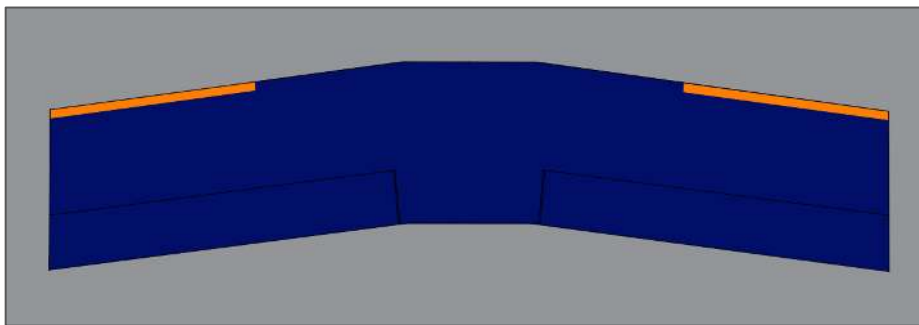

### ORACOVER COLORS

	MIDNIGHT BLUE	HANU885
	SKY BLUE	HANU875
	ORANGE	HANU877
	WHITE	HANU870

# FINAL SETUP AND FLYING NOTES

## CENTER OF GRAVITY

Setting the center of gravity (CG) is one of the most important steps for success, particularly with a new airplane. The Flex Innovations Ultimate 70cc is a high-performance airplane with large control surface throws, and a very high thrust to weight ratio. These two factors combined make the Ultimate a very enjoyable aircraft to fly, but if the center of gravity is not within an acceptable range, it will make the airplane difficult, if not impossible, to control. To have the most success and enjoyment from your Ultimate 70cc, please follow the next few steps very carefully.

Before checking the CG of your model please ensure that all the components are installed in your airplane. This means the batteries, servos, linkages, hardware, propeller, spinner, hatches; everything. The airplane must be in ready-to-fly condition, otherwise the measurement will not be accurate.

There are several methods for determining center of gravity, from using a CG machine, to using fingers and a friend. Regardless of the method used, ensure that the tests are accurate and repeatable. If there are any inconsistencies between measurements, work to isolate the source of the error(s) making sure that the test can be repeated with the same results. If lifting the model by the wing tips, do NOT lift directly from the tip of the wing, but lift at the outboard-most wing rib location or damage to the model may result.

**The location of the center of gravity for the Ultimate 70cc is 28mm AFT from the LEADING EDGE of the BOTTOM WING at the wing tip. It is critical that the starting point for your model be at this point. This measurement is determined from many test flights by designer and many time world aerobatic champion, Quique Somenzini.**

### Quique's Tip:

CG can be easily achieved using the recommended equipment and placing it in the recommended areas. However, some variance of weight between model builds is possible. For this reason, it is recommendable to leave the batteries uninstalled and finalize their installation

where necessary at the time you are setting CG in the recommended location. There are three trays in the aircraft. The front tray just ahead the gas tank, the gas tank tray, and the rudder/RX tray. Use these trays to place your batteries accordingly.

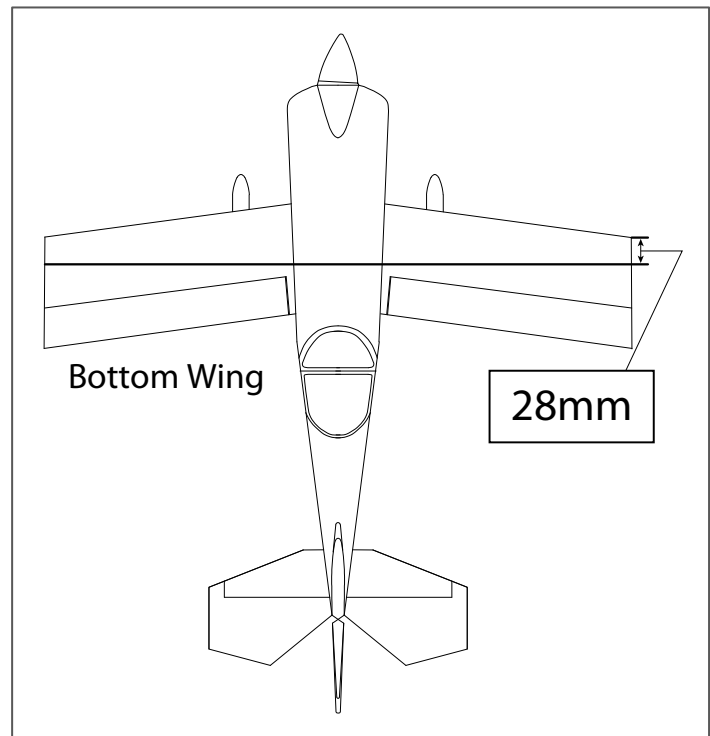

## AURA 8 PROFESSIONAL

If you choose to use Aura 8 Professional AFCS, you can find the information on the Ultimate 70cc Aura set-up in the Aura Config Tool and in the wiki at:

<http://wiki.flexinnovations.com/wiki/Ultimate70cc>

### STARTING CONTROL SURFACE THROWS AND EXPONENTIAL

The following throws and exponential have been tested thoroughly during the development of the airplane and have been determined to be the optimal starting point for the Ultimate 70cc. As you become more familiar with the airplane, you may tweak the rates and expos to better suit your flying style, but these numbers provide a very good starting point.

*NOTE: Aileron throws are measured at the trailing edge and root of the aileron. Elevator and rudder throws are measured at counterbalance, from the center of the fin or stab to the center of the counterbalance. Since expo directions vary by transmitter manufacturer, all expos listed below are those that make the control feel softer around the stick's center position.*

Ultimate 70cc Control Throws and Expo

	Low Rate		High Rate	
	Up	Down	Up	Down
<b>Aileron (top &amp; bottom wing)</b>	52mm (2-1/32 in.)	52mm (2-1/32 in.)	93mm (3-1/8 in.)	93mm (3-1/8 in.)
<b>Elevator</b>	12mm (1/2 in.)	12mm (1/2 in.)	48mm (1-7/8 in.)	48mm (1-7/8 in.)
<b>Rudder</b>	22mm (7/8 in.)	22mm (7/8 in.)	45mm (1-3/4 in.)	45mm (1-3/4 in.)
<b>Aileron Expo</b>	25%	25%	55%	55%
<b>Elevator Expo</b>	25%	25%	50%	50%
<b>Rudder Expo</b>	20%	20%	45%	45%

High rate should be reserved for 3D aerobatics and low rate should be reserved for sport/precision flying and general aerobatics. It is highly recommended that for your first flights, take offs and landings be done in low rate.

## RANGE TESTING

Carefully follow the binding and range testing instructions included with your radio equipment. If there are any issues passing the test range, please consult your transmitter and receiver manuals or contact your transmitter and receiver manufacturer to determine the appropriate solution before attempting to fly.



## BEFORE FIRST FLIGHT

Before going to the field for your first flight, please go over the finished, fully assembled model at home. The key to a successful first flight is preparation and ensuring that your plane is airworthy.

- 1. For optimal performance of your model, balance your propeller and spinner. Most propellers are balanced fairly-well out of the package; however, some fine-tuning can make a mediocre propeller perform great. An out-of-balance propeller or spinner can wreak havoc on the electronic components in the airplane, as well as prematurely shorten the life span of the engine, servos or even the model itself. A balanced propeller will be quieter, generate more thrust, produce less vibration, and operate more efficiently than one that is not balanced.
- 2. Re-check all linkages and connections, including those that may have been assembled by the factory. Ensure pushrods are sufficiently threaded into ball links, ensure that all metal-to-metal connections have thread lock applied and ensure that all control surfaces move freely and in their proper direction.
- 3. Verify proper functioning, break-in, and operation of your engine choice. Ensure that the fuel-air mixture is correct, and that the engine is producing full power. If you are not familiar with gas engines, ask for the assistance of a more experienced pilot in your area or speak with your engine manufacturer.
- 4. Secure any loose wiring inside the fuselage or wings in such a way that they do not rub or chafe.
- 5. Ensure that all batteries (transmitter, receiver, ignition, or flight packs) are fully charged prior to leaving for the flying field.
- 6. Take a few moments to assemble the airplane away from commotion, talkative onlookers, or any other distractions. Ensure that all connections are properly made and secured, the wing bolts are tight and take a few minutes to plan out your first flight.
- 7. If your gas engine is new, avoid prolonged full throttle runs and vertical climbs. Limit the first few flights to a short flight time. Start off short, gradually lengthening the flight times as you become comfortable with the performance of your engine. Six minutes is a good time to limit your first flights to. As you become more familiar with the airplane and begin to fly it in a more aggressive manner, monitor the temperature of the engine and adjust the fuel-air mixture according to your engine manufacturer's recommendations.

## AMA SAFETY CODE

When flying your aircraft, we recommend following the guidelines set by the Academy of Model Aeronautics (AMA). You can find their Safety handbook as well as more information on the AMA at their website, located at the address below.

<https://www.modelaircraft.org/>

## REPLACEMENT PARTS

FPM2100	Ultimate 70cc ARF Orange Scheme
FPM2101	Ultimate 70cc Fuselage without hatches Orange Scheme
FPM2102	Ultimate 70cc Top Wing Set Orange Scheme (Top, Left and Right)
FPM2103	Ultimate 70cc Horizontal Stabilizer with Elevators Set Orange Scheme
FPM2104	Ultimate 70cc Rudder Orange Scheme
FPM2105	Ultimate 70cc Cowling Orange Scheme with hardware
FPM2106	Ultimate 70cc Canopy Hatch Set Orange Scheme
FPM2107	Ultimate 70cc C/F Landing Gear
FPM2108	Ultimate 70cc Wheel Pants Orange Scheme with hardware
FPM2109	Ultimate 70cc Carbon Wing Tubes (x2)
FPM2110	Ultimate 70cc Tail Wheel with Hardware
FPM2111	Ultimate 70cc Main Wheel Set and Axle Set (5mm diameter)
FPM2112	Ultimate 70cc Pushrod Linkage/Control Horn Set
FPM2113	Ultimate 70cc Hardware Set
FPM2115	Ultimate 70cc Decal Sheet Orange Scheme
FPM2119	Ultimate 70cc Interplane Strut Set Scheme
FPM2120	Ultimate 70cc Laser Cut Wood Parts
FPM2121	Ultimate 70cc Bottom Wing Set (Bottom, Left and Right) Orange Scheme
FPM2122	Ultimate 70cc Hatch Orange
FPM2123	Ultimate 70cc Engine Cowling Baffle Kit
FPM2125	Ultimate 70cc Stab Tube
FPM2127	Ultimate 70cc Top Wing Central Strut Set with Joint Rib
FPM2128	Premium Vinyl Graphics Set Ultimate 70cc Orange Scheme (by Callie Graphics)
FPM2150	Ultimate 70cc ARFSV Orange Scheme
FPM2019	RV-8 70cc: Fuel Tank 700cc Aluminum Cap w/accessories

## OPTIONAL ACCESSORIES

FPM2114	Ultimate 70cc Wing and Tail Bag Set
FPM2124	Ultimate 70cc Pilot
FPM1124	15mm Aluminum Engine Standoff (1/4" ID)
FPMDA70	Desert Aircraft DA-70cc Engine
FPMDA70MUFLR	DA70 Muffler
FPM2126	Ultimate 70cc Spinner Orange
FPMHOLYG2	Holy Smokes Gen2 Smoke System
FPM2019	RV-8 70cc: Fuel Tank 700cc Aluminum Cap w/accessories (smoke)
FPMPF249CF	FLEX 24x9 Two Blade Carbon Fiber Propeller for Gas
FPZA1036	Aluminum Servo Arm 2-in Clamping (25T)
FPZA1037	Aluminum Servo Arm 4-in Clamping (25T)
FPZA1040	Servo Connector Safety Clip
FPZAURA08PRO	Aura 8 Professional AFCS
FPZAURA12PRO	Aura 12 Professional AFCS
FPZBR20002S15	2000 mAh 2s 15C JR/EC3 Connector RX Li-Po Battery Pack
FPZDS49010BLHV	Potenza DS49010BLHV Brushless Servo
ISDTD2	iSDT D2 Smart AC Dual Battery Charger 100W x 2 6s

# LIMITED WARRANTY

## Warranty Coverage

Flex Innovations LLC and its authorized resellers (“Flex”) warrant to the original purchaser that this product (the “Product”) will be free from defects in materials and workmanship at the date of purchase.

## Outside of Coverage

The warranty is not transferable and does not cover:

- (a) Products with more than 45 days after the purchase date
- (b) Damage due to acts of God, accident, misuse, abuse, negligence, commercial use, or due to improper use, installation, operation, or maintenance
- (c) Damage to other components or assemblies associated with the use of the Product.
- (d) Modification of or to any part of the Product
- (e) Product not purchased from an authorized Flex Innovations dealer or distributor.
- (f) Product that has been partially, or fully assembled
- (g) Shipping damage
- (h) Cosmetic damage
- (i) Services or labor associated with the repair, use or assembly of the Product.

***OTHER THAN THE EXPRESS WARRANTY ABOVE, FLEX MAKES NO OTHER WARRANTY REPRESENTATION, AND HEREBY DISCLAIMS ALL IMPLIED WARRANTIES, INCLUDING, WITHOUT LIMITATION, THE IMPLIED WARRANTIES OF NONINFRINGEMENT, MERCHANTABILITY AND FITNESS FOR A PARTICULAR PURPOSE. THE PURCHASER ACKNOWLEDGES THAT THEY ALONE HAVE DETERMINED THAT THE PRODUCT WILL SUITABLY MEET THE REQUIREMENTS OF THE PURCHASER’S INTENDED USE.***

## Purchaser’s Remedy

Flex’s sole obligation and purchaser’s sole and exclusive remedy shall be that Flex will, at its option, either (i) service, (ii) replace any part of the Product determined by Flex to be defective, or (iii) replace the Product determined by Flex to be defective. Flex reserves the right to inspect all Product(s) involved in a warranty claim. Service or replacement decisions are at the sole discretion of Flex. Proof of purchase is required for all warranty claims. **SERVICE OR REPLACEMENT AS PROVIDED UNDER THIS WARRANTY IS THE PURCHASER’S SOLE AND EXCLUSIVE REMEDY.**

## Limitation of Liability

**FLEX SHALL NOT BE LIABLE FOR SPECIAL, INDIRECT, INCIDENTAL OR CONSEQUENTIAL DAMAGES, LOSS OF WAY, REGARDLESS OF WHETHER SUCH CLAIM IS BASED IN CONTRACT, WARRANTY, TORT, NEGLIGENCE, STRICT LIABILITY OR ANY OTHER THEORY OF LIABILITY, EVEN IF FLEX HAS BEEN ADVISED OF THE POSSIBILITY OF SUCH DAMAGES.**

Further, in no event shall the liability of Flex exceed the individual price of the Product on which liability is asserted. As Flex has no control over use, setup, assembly, modification or misuse, no liability shall be assumed nor accepted for any resulting damage and/or injury. By the act of use, setup or assembly, the user accepts all resulting liability. If you as the purchaser or user are not prepared to accept the liability associated with the use of the Product, purchaser is advised to return the Product immediately in new and unused condition to the place of purchase.

## Law

These terms are governed by Florida law (without regard to conflict of law of principals). This warranty gives you specific legal rights, and you may also have other rights which vary from state to state. FLEX RESERVES THE RIGHT TO MODIFY THIS WARRANTY AT ANY TIME WITHOUT NOTICE.

## Questions & Assistance

Contact us by:

E-Mail – [support@flexinnovations.com](mailto:support@flexinnovations.com)

Phone – 1 (866) 310-3539

## Inspection or Services

If this Product needs to be inspected or serviced and is compliant in the region you live and use the Product in, please contact your regional Flex authorized reseller. Pack the Product securely using the original shipping carton. Please note that both the inner and outer boxes need to be included. The inner box is not designed to withstand the rigors of shipping without additional protection from the outer shipping carton. Ship via a carrier that provides tracking and insurance for lost or damaged parcels, as Flex is not responsible for merchandise until it arrives and is accepted at our facility.

## Warranty Requirements

For Warranty consideration, you must include your original sales receipt verifying the proof of purchase date. Provided any warranty conditions have been met, your Product or its defective parts will be replaced or serviced free of charge. Responsibility of shipping charges are as follows:

To Flex from customer, customer is responsible.

To Customer from Flex, Flex is responsible.

Service or replacement decisions are at the sole discretion of Flex.



© 2022 Flex Innovations, LLC. All rights reserved.  
Potenza™ is a trademarks of Flex Innovations LLC  
Futaba and S.Bus are registered trademarks of Futaba Denshi Kogyo Kabushiki Kaisha Corporation of Japan.

Rev.A  
Created 08/2022