

**XFLY-MODEL**

# X1500

---

*Overall Length: 1050mm*  
*Wingspan: 1500mm*

操作手册

*Instruction Manual*

<http://www.xfly-model.com/>



---

## \ Must-read /

---

### Warnings

Please read through the whole user manual carefully and follow the instructions strictly for product installation and operation. Improper operation may lead to product damage or property loss or even severe personal injury. Xfly-model and its distributors will not assume responsibility if damage or loss is caused by violating the instructions listed.

### Caution

This product is Not a toy! Flying experience is required by users. Beginners should only operate the product under the supervision of professionals.

This product is not intended for use by children under 14 years!

### Safety Precautions

This product is radio-controlled and subject to interference from other signal sources which may result in momentary loss of control or even crash. So please always keep a safe distance in all directions around your model in order to avoid unexpected collision or injury.

- NEVER operate your model with low transmitter batteries.
- Always operate your model in an open area with the sun behind you away from cars, traffic or people.
- Do not operate your model in bad weather such as wet weather, thunderstorm, strong wind or heavy snow.
- Always follow the instructions and pay attention to the warnings for this product and other associated devices you use (charger, rechargeable battery pack, etc.)
- Always keep all chemicals, small parts and electronic components out of reach of children.
- Do not expose the electronic components to moist environment in case of damage.
- This model kit contains small parts, plastic bags, and materials that can be harmful to children if swallowed.
- ALWAYS ensure the transmitter is turned ON with the throttle at its lowest setting before connecting model battery.

### Lithium-Polymer (Li-Po) Battery Use

Caution: Always follow the manufacturer's instructions for safe use and disposal of batteries. Improper use of Li-Po batteries may cause a fire, property damage, or severe injury.

- Do not use the battery that is swollen, or overcharged, or has been damaged. Keep in mind to discharge the battery to storage voltage (3.8-3.85V per cell) if they are not in use for a long time and as soon as possible after use for safe storage. Always store the battery at room temperature in a cool dry area to extend the lifespan of the battery. Do not store the battery in a car or expose it to direct sunlight. For maximum safety Xfly-Model recommends storing Li-Po batteries in a proper battery bunker, or sealed (not airtight) fire resistant container.
- Only use a Li-Po compatible charger to charge & discharge Li-Po batteries - NEVER try to use any other charger in case of personal injury and property damage.
- Do not discharge the Li-Po to below 3V per cell or irreversible damage can occur to the battery.
- NEVER leave charging battery unattended.
- Do not charge damaged battery - instead dispose of Li-Po batteries by fully discharging then taking to an appropriate disposal agent.

### Warning for Battery Charging

As stated previously ONLY use a Li-Po compatible charger to charge the battery. Be sure to read and understand the charger instruction manual carefully before charger use. Make sure battery is on a heat-resistant surface when being charged. It is highly recommended to place the Li-Po battery inside a fire-resistant charging bag readily available at hobby shops or online stores.

---

## \ Product Overview /

---

XFly X1500 is a long-endurance FPV platform designed for extended flight operations. Constructed from wear-resistant EPP foam and reinforced with high-strength 3D-printed plastic parts, it features a glue-free quick-assembly design that allows deployment within two minutes.

The aircraft adopts a conventional fixed-wing layout, delivering smooth and predictable flight characteristics. Its high-lift airfoil ensures efficient cruise performance, ideal for long-duration missions. Equipped with a twin power system, the X1500 achieves a thrust-to-weight ratio greater than 1 in unloaded conditions, while supporting payloads of 1KG. With its optimized aerodynamics, carefully aligned thrust line and balanced center of gravity, the X1500 can take off effortlessly either by hand launch or via ground roll. Reinforced rubber tires on the underside enable durable repeated takeoffs and landings.

The spacious battery bay accommodates a standard 21700-4S2P-10000mAh battery with additional room for extra payloads. A dedicated equipment compartment in the mid-fuselage provides ample space for installing flight controllers, GPS modules, and other avionics. Pre-configured mounting points on the FPV nose cone and battery hatch are compatible with DJI and Walksnail FPV systems, allowing quick integration of video transmission setups. The X1500 is offered in both PNP and KIT versions, giving pilots the flexibility to customize their power and battery configuration according to specific mission requirements.

### Features

- Glue-free quick-assembly design
- Twin efficient power system for a powerful and long-endurance flight experience
- Wear-resistant EPP foam and rubber tires for improved durability
- Effortlessly hand-launch or wheeled takeoff/landing
- Spacious compartments allowing easy integration of multiple avionics
- Compatible with mainstream FPV systems like DJI and Walksnail

---

## \ Table of Contents /

---

Must-read .....	02	Spare Parts List .....	11
Product Overview .....	03	User Manual of Brushless Speed Controller .....	12
Box Contents .....	04		
Product Specifications .....	04		
Assembly Instructions .....	05		
Control Horns Installation .....	07		
Battery Installation .....	07		
CG Setting .....	08		
Control Surface Testing .....	09		
Dual Rate Setting .....	10		
Trouble shooting .....	11		

## Box Contents

Please check the below parts carefully before assembly. If anything appears missing or damaged, please contact your distributor in the first instance, or send us an email (support@xfly-model.com) and advise the item name or part number of the missing or damaged part(s). (Please refer to the spare parts list on Page 11 of this manual for full parts listing). Please note that different versions can sometimes include slightly different items inside the package.

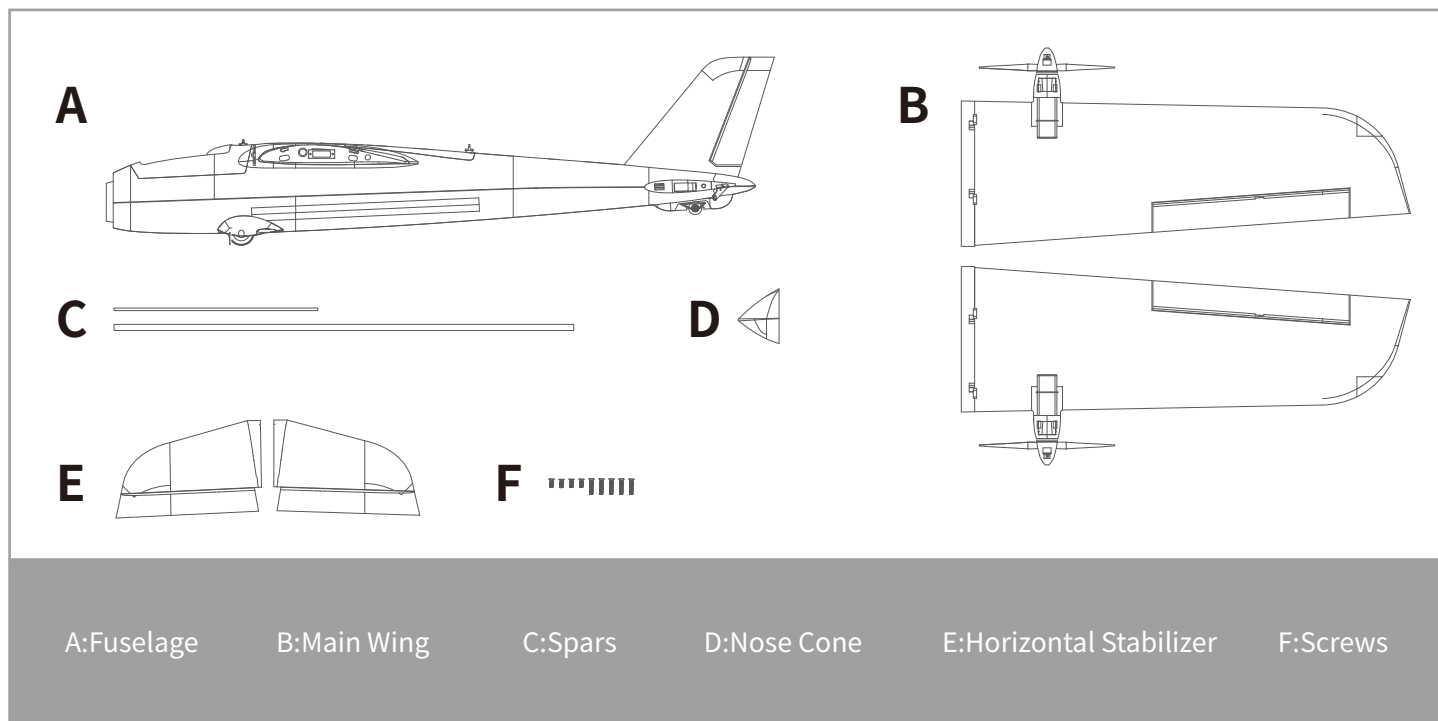

## Specifications

Material:	Wear-resistant EPP foam
Wingspan:	1500mm/59"
Overall Length:	1050mm/41.3"
Wing Load:	72g/dm <sup>2</sup>
Wing Area:	25dm <sup>2</sup>
Flying Weight:	1900g
Propeller Size:	8x5(CW&CCW) 2-blade
Motor:	2212-KV1400 *2
ESC:	40A *2
Servos:	9g metal-g geared servo *5

Flying Duration:	60 mins
Landing Gear:	Durable rubber tires
Other Electronics:	/
Channels:	4CH- aileron, elevator, throttle, rudder
Skill Level:	Intermediate
Recommended Battery:	21700 4S2P 10000mAh (≥575g)
Build&Test Time:	3mins

## Nose Cone Installation

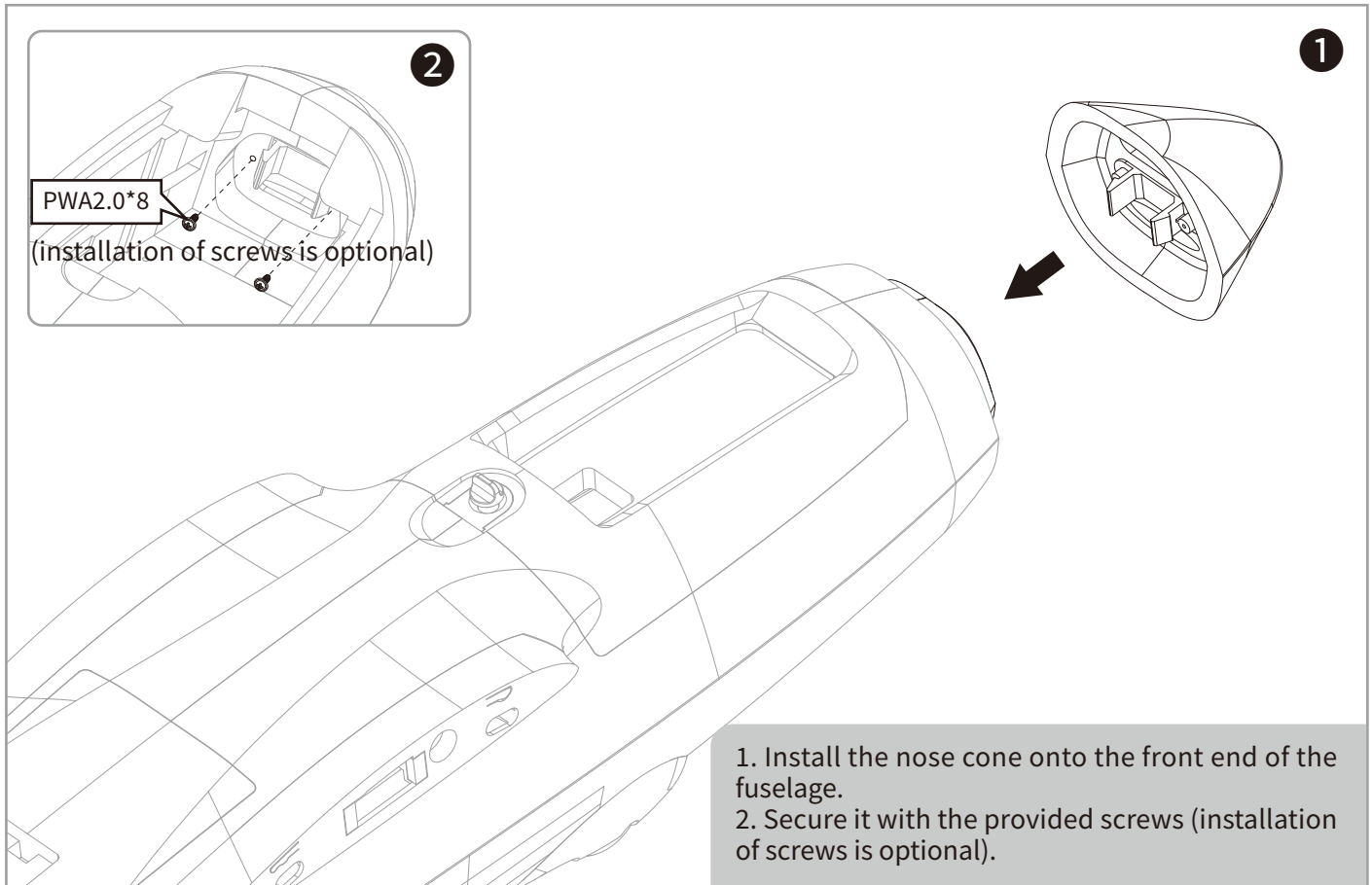

## Main Wing Installation

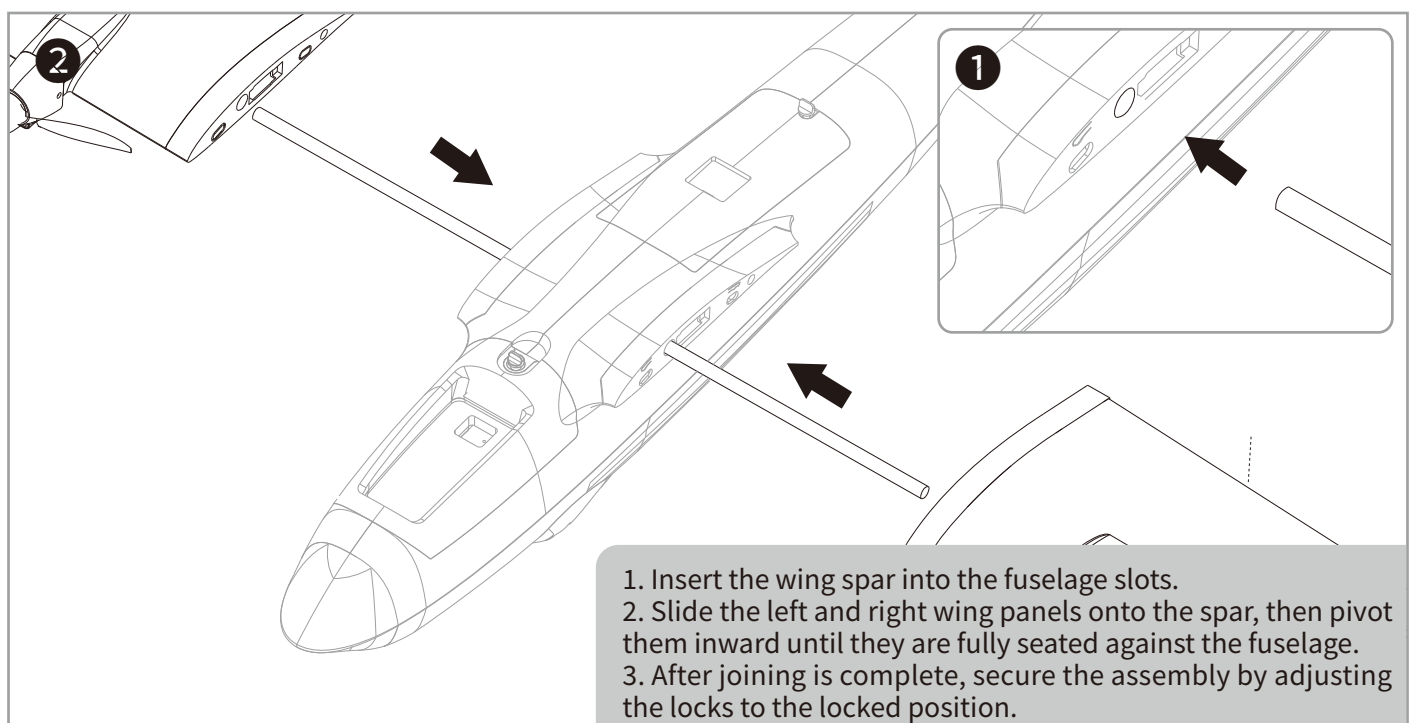

## Assembly Instructions

### Horizontal Stabilizer Installation

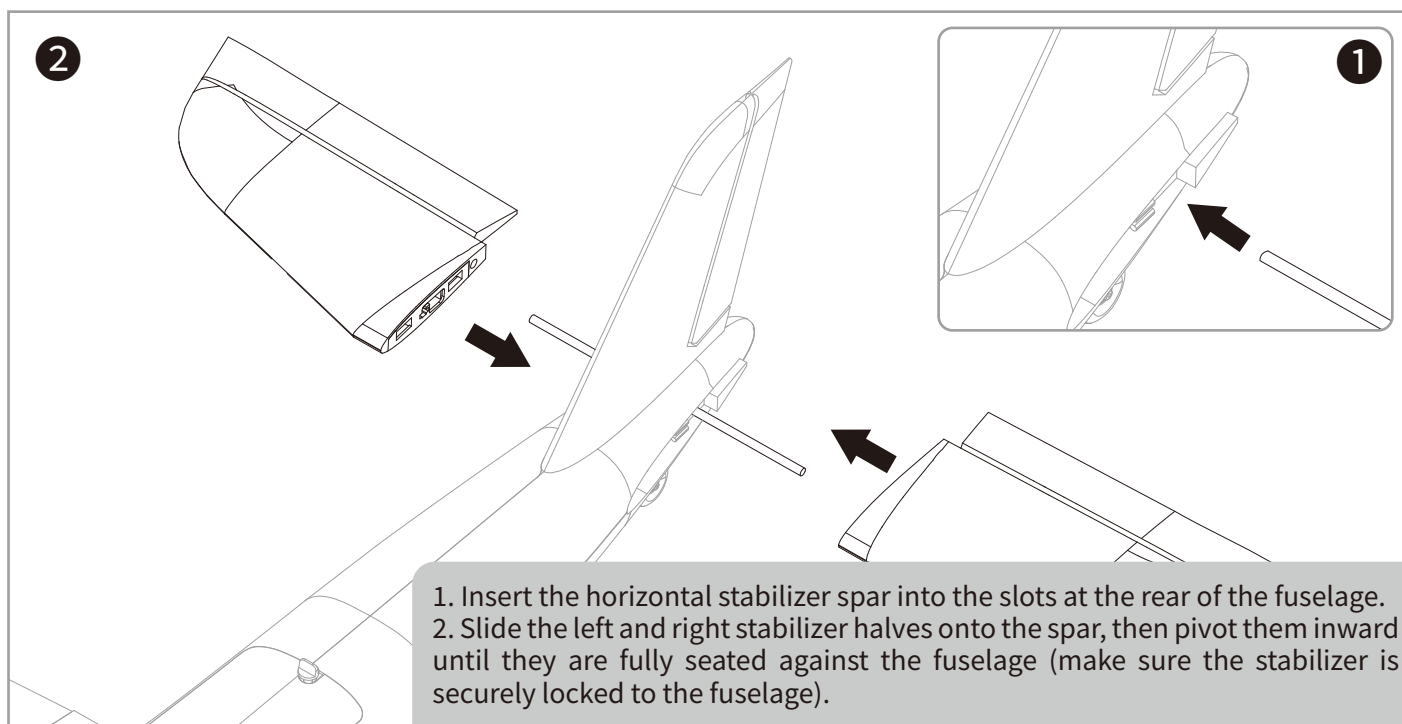

### Propeller Assembly

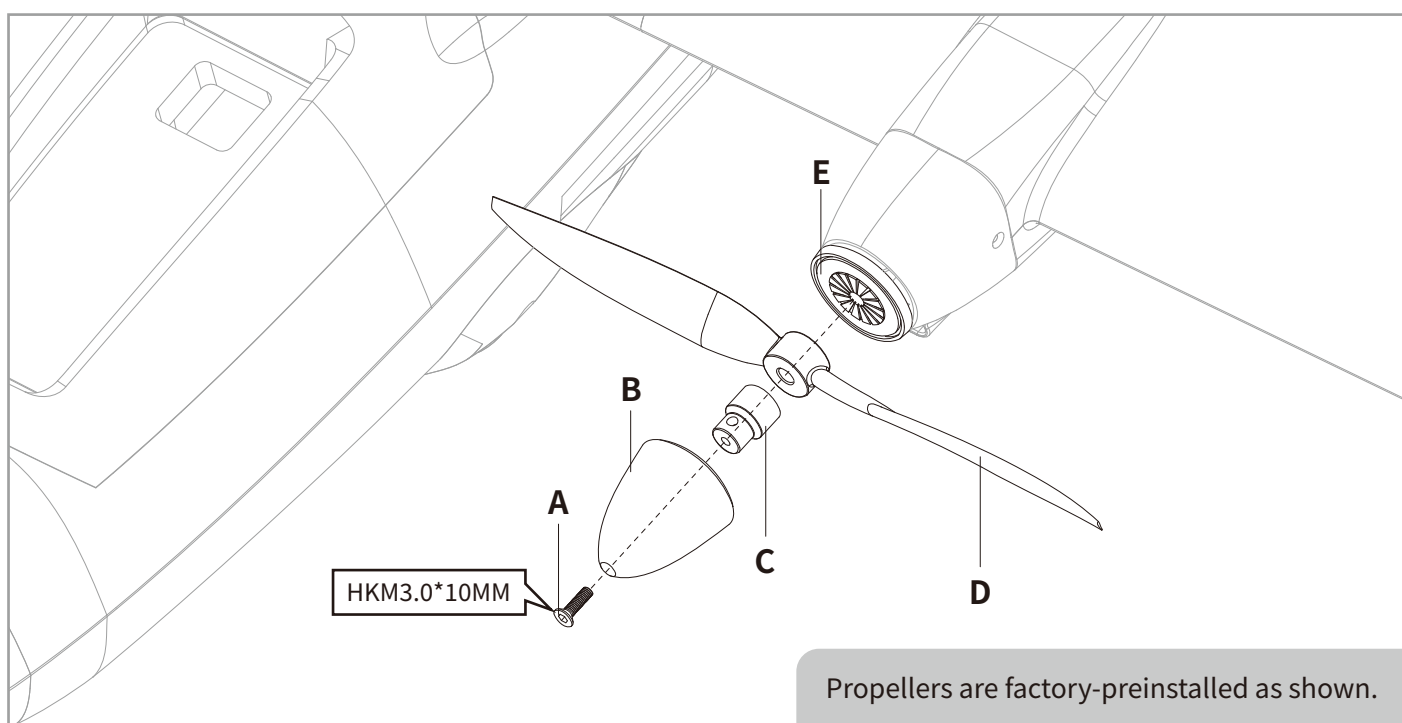

## Control Horns Installation

Make sure all servos are in their central position and adjust the linkages to the indicated positions.

The following pictures show the default factory settings for the control horns and linkages recommended for use for initial flight.

Hole reference for aileron servo linkage

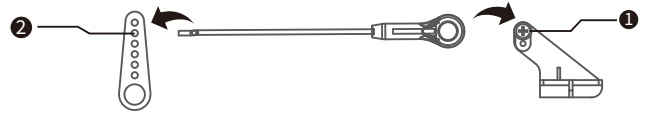

Hole reference for elevator servo linkage

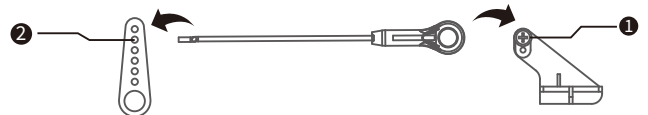

Hole reference for rudder servo linkage

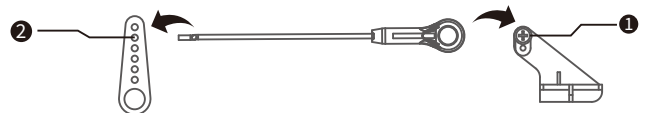

## Battery Installation

1. Before connecting the battery to the plane, power on the transmitter and ensure throttle lever in the lowest position.

2. Insert battery to the battery compartment and secure it with velcro tape.

3. If necessary reposition battery to adjust the center of gravity (CG) by moving the battery forward or backward.

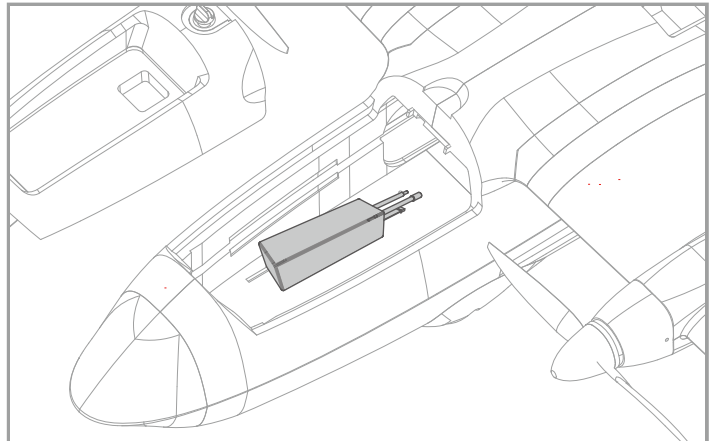

---

## \ CG Setting /

---

**Correct center of gravity is very essential for a successful flight. Please refer to the below diagram to adjust the CG of the plane.**

— Adjust the CG position by moving the battery forwards or backwards. If necessary add ballast weight to achieve the correct CG position before flight.

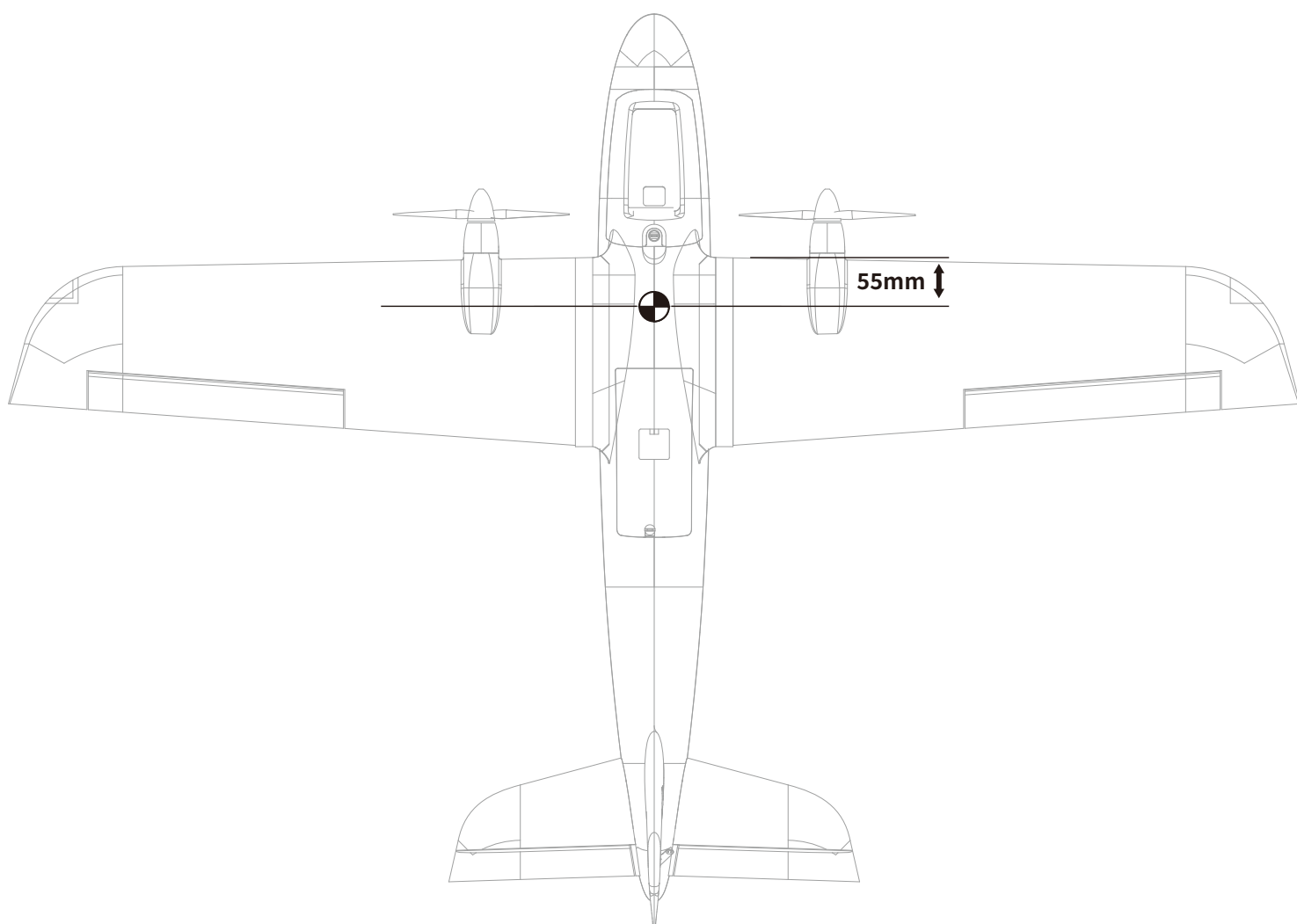

## \ Control Surface Testing /

Before each flight turn on the transmitter BEFORE connecting a fully charged battery and perform a full pre-flight functional check-pay attention to all control surfaces for correct direction of operation.

Xfly-Model Strongly recommends you also perform a full range test prior to each flight!

Note: SAFETY FIRST!! Please remove the propeller(where applicable) before carrying out any pre-flight maintenance to the power system to prevent potential injury from unintended propeller operation.

**ALWAYS CHECK CONTROL SURFACE DIRECTION FROM BEHIND THE MODEL LOOKING FORWARD TO ENSURE CORRECT OPERATION**

**Aileron control lever moving leftward**

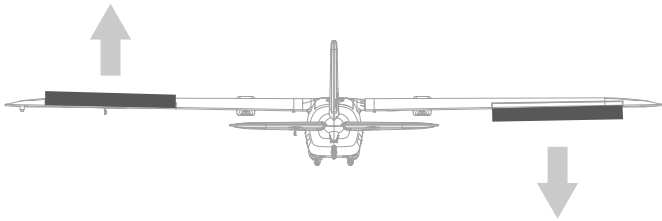

**Aileron control lever moving rightward**



**Elevator control lever moving downward**

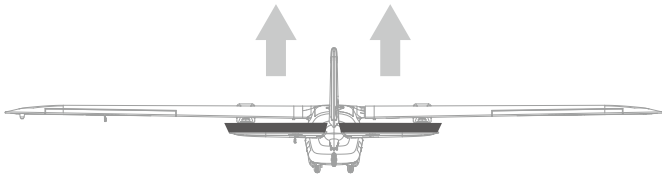

**Elevator control lever moving upward**

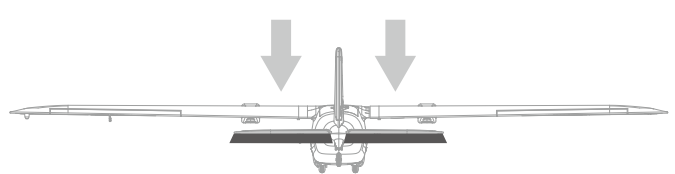

**Rudder control lever moving leftward**

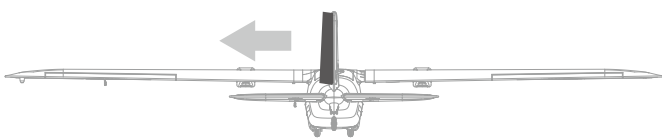

**Rudder control lever moving rightward**

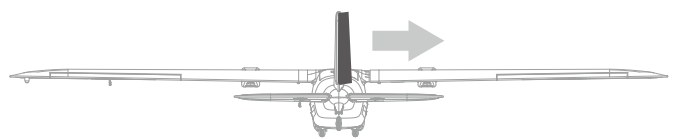

## Dual Rate Setting

Based on Xfly Model's testing experience, the following rates are recommended for optimum performance. Operation on airplanes with low rates is usually clumsy while on those with high rates is usually agile. It is suggested that initial flights are carried out using high rates until you are comfortable with the flight characteristics of the plane.

### Aileron

### Elevator

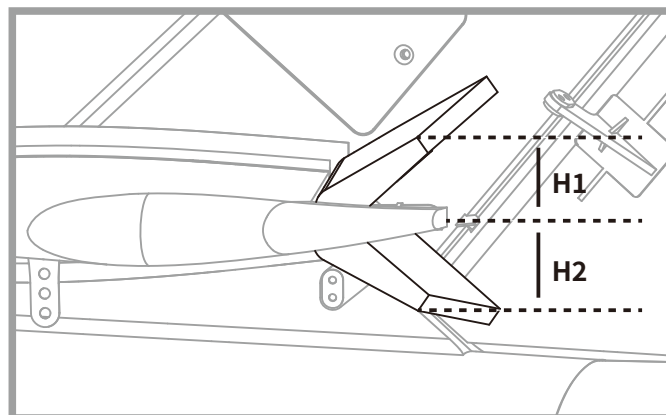
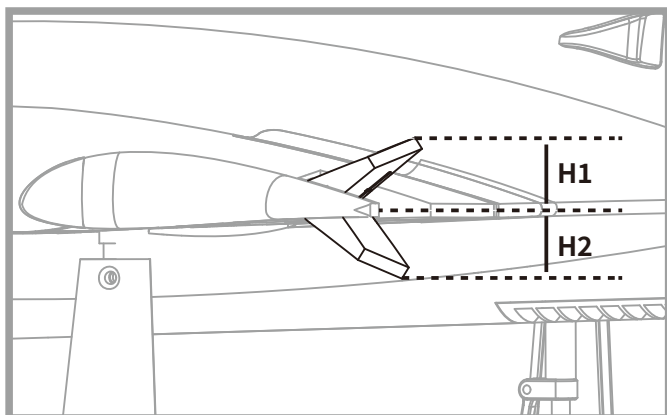

### Rudder

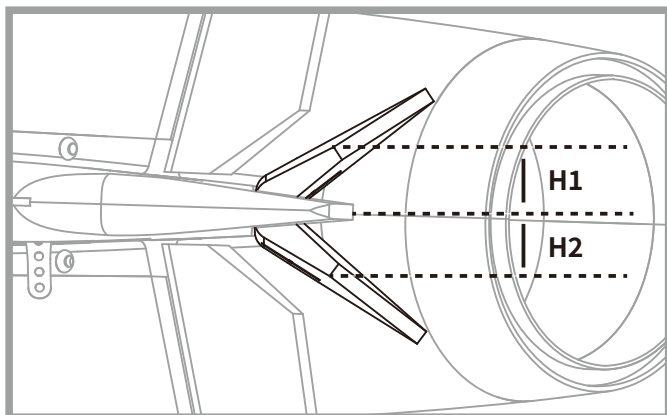

	Aileron	Elevator	Rudder	Flaps
<b>Low dual rate(H1/H2)</b>	13mm/70%	10mm/70%	12mm/70%	/
<b>High dual rate(H1/H2)</b>	18mm/100%	15mm/100%	17mm/100%	/

## \ Trouble Shooting /

Problem	Possible Cause	Solution
Aircraft not responding to the throttle but responding to other controls	-ESC not calibrated -throttle deactivated on radio -motor wire disconnected	-Calibrate ESC according to manual -activate throttle on radio -check motor wires and connect/repair as required
Excessive propeller noise or Excessive vibration	-Propeller/EDF loose or damaged -Propeller/EDF out of balance -Propeller/EDF fan incorrectly installed or mounting loose	-Tighten and/or Replace damaged parts -balance propeller/EDF unit -Remove and install the propeller correctly -ensure mounting tight and parts correctly fitted
Reduced flight times or aircraft underpowered	-Low battery charge -ESC overheating -Defective battery	-Recharge battery -Ensure adequate cooling to ESC -Replace battery with new one
Control surface not moving, or responds slowly to control inputs	-Control surface, control horn, linkage or servo damaged -Wire damaged or connector loose	-Replace or repair damaged parts and adjust controls -Check all wires and ensure connections are secure -Repair/replace damaged wires or connectors
Control surface reversed	Channels reversed on the transmitter	-Check transmitter settings and adjust as required
Motor losing power in flight	-ESC not calibrated correctly -ESC LVC low voltage cutoff activated -Defective motor, ESC, or battery	-Recalibrate ESC -Check the battery, transmitter, receiver, ESC, motor and replace it if defective -Get the aircraft land immediately and recharge the battery
Slow LED flash on the receiver	Receiver power loss	-Check the connection between ESC and receiver -Check if servo is damaged -Check if the linkages are in place

## \ Spare Parts List /

XFW004-01	Fuselage	XF113X-12	8x5(CW&CCW) 2-Blade Propeller
XFW004-02	Main Wing Set	XF113-15	Servo-equipped Camera Mount
XFW004-03	Horizontal Stabilizer Set	XFKV1400	2212-KV1400 Motor
XFW004-04	Foam Nose Cone	XFESC40A-2	X1500 40A ESC
XFW004-05	Battery Hatch	XFPSER9P-50	9g Digital MG Servo
XFW004-06	FPV Hatch		Positive w/50mm Lead
XFW004-07	Equipment Hatch	XFPSER9P-400	9g Digital MG Servo
XFW004-08	Front Wheel Set		Positive w/400mm Lead
XFW004-09	Rear Wheel Set	XFPSER9R-50	9g Digital MG Servo
XFW004-10	FPV Nose Cone		Reverse w/50mm Lead
XFW004-11	Spinner (1pc)		
XFW004-12	Wing Spar		
XFW004-13	Elevator Spar		
XFW004-14	Linkage Set		
XFW004-15	Control Horn Set		
XFW004-16	LED Light Set		
XFW004B-17	Decal Sheet - Blue		
XFW004R-17	Decal Sheet - Red		

# BRUSHLESS ESC User Manual

Thank you for purchasing XFly Model Brushless Electronic Speed Controller(ESC).

High power systems for RC model can be very dangerous and we strongly suggest that you read this manual carefully. XFly Model have no control over the use, installation, application, or maintenance of these products, thus no liability shall be assumed nor accepted for any damages, losses of costs resulting from the use of this item. Any claims arising from the operating, failure or malfunctioning etc. will be denied. We assume no liability for personal injury property damage or consequential damages resulting from our product or our workmanship. As far as is legally permitted, the obligation for compensation is limited to the invoice amount of the product in question.

The XFly Model ESC's high powerBEC has been specifically designed for extreme aerobatics and therefore has the capability to support the higher momentary peak demand loads to eliminate the possibility of unwanted shutdowns. and is also capable of supporting continuous simultaneous multiple servo operations typically found in CCPM equipped hardcore 3D E-helicopters.

## Wires Connection:

The speed controller can be connected to the motor by soldering directly or with high quality connectors. Always use new connectors, which should be soldered carefully to the cables and insulated with heat shrink tube. The maximum length of the battery pack wires shall be within 6 inches.

- Solder controller to the motor wires.
- Solder appropriate connectors to the battery wires.
- Insulate all solder connectors with heat shrink tubes.
- Plug the "JR" connector into the receiver throttle channel.
- Controller Red and Black wires connects to battery pack Red and Black wires respectively.

## Brushless Speed Controller

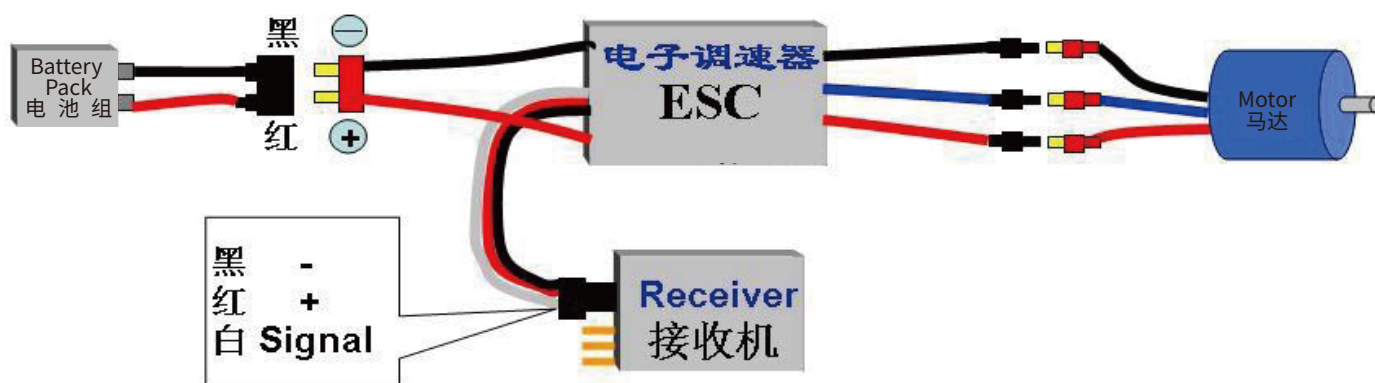

## Specification:

Type	Cont. Current(A)	Burst Current (A) 10 sec	Battery cell NiXX/Lipo	Weight (g)	BEC Output	Size(mm) W*L*H	User Program
12A BEC	12A	16A	5-12NC\2-4Lipo	8	5.0V/1A	21x22x4	yes
20A BEC	20A	30A	5-12NC\2-4Lipo	18	5.0V/2A	23x33x6	yes
30A BEC	30A	40A	5-12NC\2-4Lipo	28	5.0V/3A	23x43x6	yes
40A SBEC	40A	60A	5-18NC\2-6Lipo	32	5.5V/4A	23x52x7	yes
50A SBEC	50A	70A	5-18NC\2-6Lipo	45	5.5V/4A	31x58x11	yes
60A SBEC	60A	80A	5-18NC\2-6Lipo	45	5.5V/4A	31x58x11	yes
70A SBEC	70A	90A	5-18NC\2-6Lipo	53	5.5V/5A	31x57x12	yes
85A SBEC	85A	100A	5-18NC\2-6Lipo	62	5.5V/5A	36x62x16	yes

## **Features:**

- ◆ Extremely low internal resistance
- ◆ Super smooth and accurate throttle linearity
- ◆ Safety thermal over-load protection
- ◆ Auto throttle shut down in signal loss situation
- ◆ Supports high RPM motors
- ◆ Power arming protection (prevents the motor from accidentally running when switched ON)
- ◆ New Advanced programming software

## **Our ESC allows you to program all functions to fit your specific needs, which makes it very efficient and user friendly:**

1. User programmable brake setting (we recommend using brake for only folding props applications)
2. User programmable battery type (LiPo or NiCad/NiMH)
3. User programmable low voltage cutoff setting
4. User programmable factory default setup restore
5. User programmable timing settings (to enhance ESC efficiency and smoothness)
6. User programmable soft acceleration start ups (for delicate gearbox and helicopter applications)
7. User programmable governor mode (for helicopter applications)
8. User programmable motor rotation (clockwise\counterclockwise)
9. User programmable switching frequency
10. User programmable low voltage cutoff type (power reduction or immediate shutdown)

## **Settings:**

### **1. Brake: ON/OFF**

\* ON - Sets the propeller to the brake position when the throttle stick is at the minimum position (Recommended for folding props).

\* OFF - Sets the propeller to freewheel when the throttle stick is at the minimum position.

### **2. Battery type: LiPo or NiCad/NiMH**

\* NiCad/NiMH - Sets Low Voltage protection threshold for NiCad/NiMH cells.

\* LiPo - Sets Low voltage protection threshold for LiPo cells and automatically detects the number of cells within the pack.

Note: Selecting the NiCad/NiMH option for the battery type, triggers the ESC to automatically set the cutoff threshold to the factory default of 60%. The cutoff threshold can then be subsequently altered through the Low Voltage protection function, if required. The ESC will read the initial voltage of the NiCad/NiMH pack once it is plugged in and the voltage read will then be used as a reference for the cutoff voltage threshold.

### **3. Low Voltage Protection Threshold ( Cutoff Threshold ):**

Low/Medium/High

1) For Li-Po packs - number of cells are automatically calculated and requires no user input apart from defining the battery type. This ESC provides 3 setting options for the low voltage protection threshold; Low (2.8V)/ Medium (3.0V)/ High (3.2V) For example: the voltage cutoff options for an 11.1V/ 3 cell Li-Po pack would be 8.4V (Low)/ 9.0V (Med)/ 9.6V (High)

2) For Ni-MH packs - low / medium / high cutoff voltages are 50%/60%/65% of the initial voltage of the battery pack. For example: A fully charged 6 cell NiMH pack's voltage is  $1.44V \times 6 = 8.64V$  when "LOW" cutoff voltage is set, the cutoff voltage is:  $8.64V \times 50\% = 4.32V$  and when "Medium" or "High" is set, the cutoff voltage is now  $8.64V \times 65\% = 5.616V$ .

### **4. Restore factory setup defaults:**

Restore - Sets the ESC back to factory default settings;

Brake:	OFF
Battery type Detect:	LiPo with Automatic Cell
Low voltage cutoff threshold:	Medium (3.0V/60%)
Timing setup:	Automatic
Soft Acceleration Start UP:	Soft Acceleration
Governor mode:	RPM OFF
Frequency:	8kHz
Low voltage cutoff type:	Reduce power

### **5. Timing setup : Automatic/ Low / High.**

\* Automatic (7-30deg) - ESC automatically determines the optimum motor timing.

\* Low (7-22 deg) - Setting for most 2 pole motors.

\* High (22-30 deg) - setting for motors with 6 or more poles.

In most cases, automatic timing works well for all types of motors. However for high efficiency we recommend the Low timing setting for 2 pole motors (general in-runners) and high timing for 6 poles and above (general outrunners). For higher speed, High timing can be set. Some motors require different timing setups therefore we suggest you to follow the manufacturer recommended setup or use the automatic timing setting if you are unsure.

Note: Run your motor on the ground first after making any changes to your motor timing!

## 6. Soft Acceleration Start ups: Very Soft / Soft Acceleration/ Start Acceleration

\* Very Soft - Provides initial slow 1.5 sec ramp-up from start to full rpm intended to protect delicate gears from stripping under instant load. This setting is recommended for either fixed wing models equipped with gearboxes and / or helicopters.

\* Soft Acceleration- Provides initial slow 1 sec ramp-up from start to full rpm. This setting is recommended for either fixed wing models equipped with gearboxes and or helicopters.

\* Start Acceleration - Provides quick acceleration start ups with a linear throttle response. This is recommended for fixed wing models fitted with direct drive setups.

## 7. Active RPM Control (Heli Governor mode)

\*RPM Control OFF

\*First Range: There will be a 5-second delay from start to full rpm, but if the throttle is cutoff after starting, then the next start will be as normal start.

\*Second Range: There will be a 15-second delay from start to full rpm, but if the throttle is cutoff after starting, then the next start will be as normal start.

Note: Once the Governor Mode is enabled, the ESC's Brake and Low Voltage Cutoff Type settings will automatically be reset to No Brake and Reduce Power respectively regardless of what settings they were previously set.

## 8. Motor Rotation: Forward /Reverse

In most cases motor rotation is usually reversed by swapping two motor wires.

However, in cases where the motor cables have been directly soldered the ESC cables, motor rotation can be reversed by changing the value of setting on the ESC.

## 9. Switching Frequency: 8kHz/16kHz

\* 8kHz - Sets ESC switching frequency for 2 pole motors, e.g. in-runners.

\*16kHz - Sets ESC switching frequency for motors with more than 2 poles, e.g.out-runners.

Although 16kHz is more efficient with our Thrust motors, the setup default is 8kHz due to the higher RF noises caused at 16kHz.

## 10. Low Voltage Cutoff Type : Reduce Power / Hard cutoff

\* Reduce Power - ESC reduces motor power when the pre-set Low Voltage Protection Threshold Value is reached (recommended).

\* Hard Cutoff - ESC instantly cuts motor power when the pre-set Low Voltage Protection Threshold value is reached.

## Programming Mode Audible Tones

Programming Mode Audible Tones		ESC Functions
Throttle Calibration		
(within the first 4 Sec ) ●● ●● ●● ●●		
1	Brake * * * * _ _ _ _	Brake On/Off
2	Battery type ~ ~ ~ ~ ~~ ~~ ~~ ~~	NiCad/NiMH LiPo
3	Low Voltage Cutoff Threshold * * * * * * * * _ _ _ _ _ _ _ _ * * * * * * * * _ _ _ _ _ _ _ _ * * * * * * * * _ _ _ _ _ _ _ _	Low2.8V/50% Medium3.0V/60% High3.2V/65%
4	Restore Factory Setup Defaults _ _ _ _	Restore
5	Timing Setup - - - - - - - - - - - -	Automatic(7-30°) Low(7-22°) High(22-30°)
6	Soft Acceleration Start Ups ∨∨ ∨∨ ∨∨ ∨∨ ∨ ∨ ∨ ∨ ∨∨∨ ∨∨∨ ∨∨∨ ∨∨∨	Very Soft Soft Acceleration Start Acceleration

7	Governor Mode	
	* * * *	Rpm off
	** ** ** **	Heli first range
	*** **	Heli second range
8	Motor Rotation	
	W W W W	Forward/Reverse
9	Switching Frequency	
	// // // //	8kHz
	\\ \\ \\ \\	16kHz
10	Low Voltage Cutoff Type	
	- - - -	Reduce Power
	- - - -	Hard Cut Off

## Using Your New ESC

Improper polarity or short circuit will damage the ESC therefore it is your responsibility to double check all plugs for proper polarity and firm fit BEFORE connecting the battery pack.

### Alert Tones

1. The ESC is equipped with audible alert tones to indicate abnormal conditions at power up.
2. Continuous beeping tone (\*\*\*\*) - Indicates that throttle stick is not in the minimum position.
3. Single beeping tone followed by a one second pause (\* \* \* \*)- Indicates that the battery pack voltage exceeds the acceptable range. (The ESC automatically checks and verifies the battery voltage once the battery is connected).

### Built-in Intelligent ESC Safety Functions

1. Over-heat protection: When the temperature of ESC exceeds 110 deg C, the ESC will reduce the output power to allow it too cool.
2. Lost Throttle signal protection: The ESC will automatically cut power to the motor when it detects a loss of throttle signal for 2 second, then motor will emit continuous beeping tone.

### Powering up the ESC for the first time and setting the Automatic Throttle Calibration

The ESC features Automatic Throttle Calibration to attain the smoothest throttle response and resolution throughout the entire throttle range of your transmitter. This step is done once to allow the ESC to "learn and memorize" your Transmitter's throttle output signals and only repeated if you change your transmitter.

1. Switch your Transmitter ON and set the throttle stick to its maximum position.
2. Connect the battery pack to the ESC. Wait for about 2 seconds, the motor will beep for twice, then put the throttle in the minimum position, the motor will also beep, which indicates that your ESC has got the signal range of the throttle from your transmitter.

**The throttle is now calibrated and your ESC is ready for operation.**

### Entering the Programming Mode:

1. Switch your Transmitter **ON** and set the throttle to its **maximum** position.
2. Connect the battery pack to the ESC.
3. Wait until you hear two short beeps (•• •• ••) confirming that the ESC has now entered the programming mode.
4. If the throttle stick is left in the **maximum** position beyond 5 seconds. the ESC will begin the sequence from one function and its associated setting options to another. (Please refer to the table below to cross reference the functions with the audible tones).
5. When the desired tone for the function and setting option is reached, move the throttle stick down to its **minimum** position. ESC will emit two beeps (\*\*) confirming the new setting has been stored.
6. The ESC only allows the setting of one function at a time Therefore should you require making changes to other function. disconnect the battery pack and wait 5 seconds to reconnect the battery and repeat the above steps.

### Normal ESC start up procedure:

1. Switch your transmitter **ON** and set the throttle to its **minimum** position.
2. Connect the battery pack to the ESC.
3. When the ESC is first powered up, it emits two sets of audible tones in succession indicating the status of its working status.

\* The first set of tones denotes the number of cells in the Li Po pack connected to the ESC. (Three beeps (\*\*\*) indicates a 3 cell LiPo pack while 4 beeps (\*\*\*\*) indicates a 4 cell LiPo pack)

\* The second set denoting Brake status (one beep(\*) for Brake "ON" and two beeps (\*\*) for Brake "OFF").

\* The ESC is now ready for use.

## General Safety Precautions

- Do not install the propeller (fixed wing) or drive pinion(helicopter) on the motor when you test the ESC and motor for the first time to verify the correct settings on your radio. Only install your propeller or pinion after you have confirmed that the settings on your radio is correct.
- Never use ruptured or punctured battery cells.
- Never use battery packs that are known to overheat.
- Never short circuit battery or motor terminals.
- Always use proper insulation material for cable insulation.
- Always use proper cable connectors.
- Do not exceed the number of cells or servos specified by the ESC.

Wrong battery polarity will damage the ESC and void the warranty.

- Install the ESC in a suitable location with adequate ventilation for cooling. This ESC has a built-in over temperature cutoff protection feature that will immediately cut power to the motor once the ESC temperature exceeds the 230 Deg F/ 110 Deg C high temperature limit.
- Use only batteries that are supported by the ESC and ensure the correct polarity before connecting.
- Switch your Transmitter ON and ensure the throttle stick is in the minimum position before connecting the battery pack.
- Never switch your transmitter **OFF** while the battery is connected to your ESC.
- Only connect your battery pack just before flying and do not leave your battery pack connected after flying.
- Handle your model with extreme care once the battery pack is connected and keep away from the propeller at all times. Never stand in-line or directly in front of any rotating parts.
- Do not immerse the ESC underwater or allow it to get wet while powered up.
- Always fly at a designated flying site and abide by the rules and guidelines set by your flying club.

## Trouble Shooting

Trouble	Possible Reason	Action
Motor doesn't work, but there are audible tones signalling the number of cells after Powering up ESC.	The ESC throttle calibration has not set up.	Set up the ESC throttle calibration
Motor doesn't work and no audible tone emitted after connecting the battery. Servos are not working either	Poor/ loose Connection between battery Pack and ESC	Clean connector terminals or replace connector
	No power	Replace with a freshly charged battery pack
	Poorly soldered connections (dry joints)	Re-solder the cable connections
	Wrong battery cable polarity	Check and verify cable polarity
	ESC throttle cable connected to receiver in the reverse polarity	Check the ESC cable connected to the ESC to ensure the connectors are in the correct polarity
Motor doesn't work and no audible tone emitted after connecting the battery BUT servos are working. Or motor doesn't work after powering up the ESC. An alert tone with single beeping tones followed by a short Pause (****) is emitted,	Faulty ESC	Replace ESC
	Poor / loose connection between ESC and motor	Clean connector terminals or replace connectors
	Burnt motor coils	Replace motor
	Poorly soldered connections(dry joints)	Re-solder the cable connections
Motor doesn't work after powering up the ESC. An alert tone with continuous beeping tones (****) is emitted.	The battery pack voltage exceeds the acceptable range.	Replace with a freshly charged battery pack Check battery pack voltage
	The throttle stick is not in the minimum position at power up	Move the throttle stick to the minimum position.

Trouble	Possible Reason	Action
Motor doesn't work after powering up the ESC. ESC emits two audible tones followed by short beeps ( .. .. .)	Reversed throttle channel caused the ESC to enter the Programming mode.	Enter the servo reverse menu on your transmitter and reverse the throttle channel! Note:For Futaba radios set the throttle channel to Reverse.
Motor runs in reverse rotation	Wrong cables polarity between the ESC and the motor.	Swap any two of the three cable connections between the ESC and the Motor or access the Motor Rotation function via the ESC programming mode and change the pre-set parameters.
Motor stops running in flight	Lost throttle signal	Check proper operation of the radio equipment. Check the placement of the ESC and the Receiver and check the route of the receiver's aerial and ESC cables to ensure there is adequate separation to prevent RF interference. Install a ferrite ring on the ESC's throttle cable.
	Battery Pack voltage has reached the Low Voltage Protection threshold.	Land the model immediately and replace the battery pack.
	Possible bad cable connection	Check and verify the integrity of the cable connections
Motor restarts abnormally ESC Overheats	Possible RF Interference at the flying field.	The normal operation of the ESC may be susceptible to surrounding RF interference, Restart the ESC to resume normal operation on the ground to verify recurrence, If the problem persists, test the operation of the ESC at a different flying field.
	Inadequate Ventilation	Relocate the ESC to allow better ventilation
	Servos drawing too much current and over loading the ESC.	Use servos that are adequately sized for the ESC. The maximum BEC current drawn should be within the BEC limits.
	Over sized motor or prop	Reduce Prop size or resize the motor



## 警告

组装、调整及飞行前请务必认真阅读产品说明书以熟知产品的特性。请严格按照说明书提示进行飞机的组装、调整及飞行。如操作不当会造成产品本身损坏及其它财产损失,甚至造成严重的人身伤害。迅飞模型及其销售商,对于违反说明书的要求操作而造成的损失、将不负任何法律责任!

## 声明

模型不是玩具,具有一定的危险性,操作者需要具备一定的飞行经验,初学者请在专业人士指导下操作。飞机的使用年龄必须是14岁以上的儿童或者成人!

## 操作使用安全须知

本产品飞行由无线电遥控器控制,在飞行过程中可能会受到外界强信号源干扰而导致失控,甚至坠机。因此,在飞行过程中务必始终与飞机保持一定的安全距离,避免意外碰撞、受伤。

- 请勿在发射器电池低电量的情况下操纵模型飞机。
- 请勿在在公共场合、高压线密集区、高速公路附近、机场附近或者其它法律法规明确禁止飞行的场合飞行。
- 请勿在雷雨、大风、大雪或者其它恶劣气象环境下飞行。
- 请严格遵照产品指导说明及安全警告操作本产品及其相关配置(例如充电器、电池等)。
- 请勿将相关化工类产品、零部件、电子部件等置于儿童可触及的范围。
- 请勿将电子件暴露于潮湿的环境中,以免造成损坏。
- 请勿将本产品任意处置于口中,以免造成人身伤亡。
- 在任何情况下,都必须保证油门杆处于起始位、发射机处于打开状态时,才能连接模型飞机内部的动力电池。

## 锂聚合物电池使用安全须知

使用锂聚合物电池时,须严格遵守制造商说明、要求并了解相关风险,使用不当会导致锂聚合物电池起火,从而造成严重的财产损失甚至人身伤害。

- 禁止使用变形、胀气的锂聚合物电池。
- 禁止使用过充、放电的锂聚合物电池,避免发生危险。长时间不使用须将锂聚合物电池放电至存储电压(3.8~3.85V/节)。锂聚合物电池须储存在室内干燥区域(4.5~48.5°C),禁止将锂聚合物电池置于阳光下暴晒或车内,高温可能会导致锂聚合物电池起火,造成财产损失和人身伤害。
- 请使用专用充电器对锂聚合物电池进行充放电,禁止使用其它,如:镍氢电池充电器。充放电时,禁止将锂电池放置于高温物体表面,建议使用锂电池防爆袋。不正确的充放电操作会对锂聚合物电池造成损伤,甚至会引起火灾,造成财产损失和人身伤害。
- 禁止将锂聚合物电池单节电压放至低于 3V,禁止给已损坏的锂聚合物电池充电。
- 锂聚合物电池充放电须在有人看管的情况下进行,避免发生意外造成不必要的损失。
- 损坏或者报废处理的模型飞机电池,应妥善回收处理,不准随意抛弃,避免自燃而引发火灾。

## 飞机电池充电须知:

请确保使用合格的电池充电器给锂电池充电。在使用充电器前,请认真阅读充电器说明书。充电过程中,请确保把电池置于耐热的表面。建议把锂电池置于防火充电袋内充电,防火充电袋可在相关模型实体店或网上买到。

## 产品简介

X1500 是迅飞团队专为长航时 FPV 飞行打造的一款高性能载机。整机采用耐磨 EPP 泡沫材质，结合高韧性 3D 打印塑胶零件与零胶水快拆设计，可实现 2 分钟快速部署飞行。

该机采用常规固定翼布局，飞行手感顺滑流畅；翼型具备高升阻比特质，充分满足长航时需求；配备双发动动力系统，空载推重比超过 1，可支持 1KG 的大载重飞行任务。经过优化的气动布局，配合精准推力线与重心匹配，使其轻松兼容滑跑起飞或者手抛起飞两种模式。机腹装有高耐磨橡胶轮胎，保障多次起降的耐久性。

机身设计注重实用拓展性，电池仓空间宽裕，标配 21700-4S2P-10000mAh 电池后仍有余量搭载其它载荷；机身中部设有大容积设备仓，便于玩家自行安装飞控导航类设备。FPV 机头与电池舱盖均预留图传与摄像头安装位，兼容大疆和蜗牛等设备。X1500 将提供 PNP 和 KIT 两种版本，玩家可根据自身需求灵活搭配电池和动力配置。

### 特征

- 快速部署，即飞即用
- 双发强动力，大载重长航时
- 耐磨 EPP 泡沫材质和橡胶轮胎，经久耐用
- 轻松手抛或滑跑起飞
- 模块化多任务载荷架构
- 兼容主流 FPV 系统

## 目录

使用必读 .....	19	配件列表 .....	28
产品简介 .....	20	电调说明 .....	29
产品包装清单 .....	21		
产品参数 .....	21		
产品组装说明 .....	22		
舵角摇臂安装 .....	24		
电池安装 .....	24		
重心调整 .....	25		
舵面测试 .....	26		
推荐舵面行程 .....	27		
故障检修 .....	28		

## 产品包装清单

在组装产品之前,请仔细检查以下配件,如有缺失或者损坏,请及时联系商家或者邮件至厂家(support@x-fly-model.com),告知缺失或损坏的配件名称及编码(请在本说明书尾页查看相应的配件编码)。请注意,不同配置,包装盒内部物品不同。

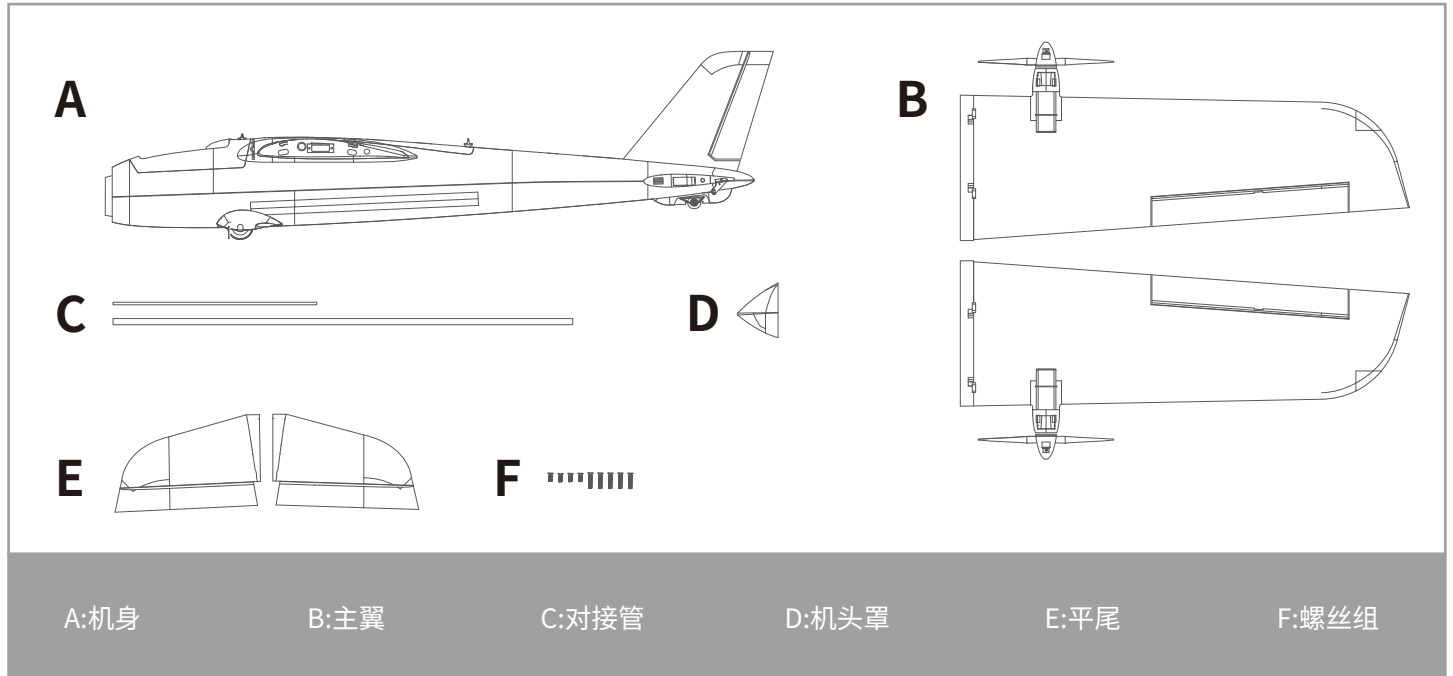

## 产品参数

材料:	耐磨 EPP 泡沫材质
翼展:	1500mm
机身长度:	1050mm
翼载荷:	72g/dm <sup>2</sup>
机翼面积:	25dm <sup>2</sup>
起飞重量:	1900g
桨叶尺寸:	8x5 正反两叶
电机:	2212-KV1400 *2
电调:	40A *2

舵机:	9g 金属舵机 *5
持续飞行时间:	60 mins
起落架:	耐磨橡胶轮胎
其他电子设备:	/
通道介绍:	4CH- 副翼, 升降, 油门, 方向
模型难度:	中级
推荐锂电池:	21700 4S2P 10000mAh (≥575g)
组装调试时长:	~ 3 分钟

## 机头罩安装

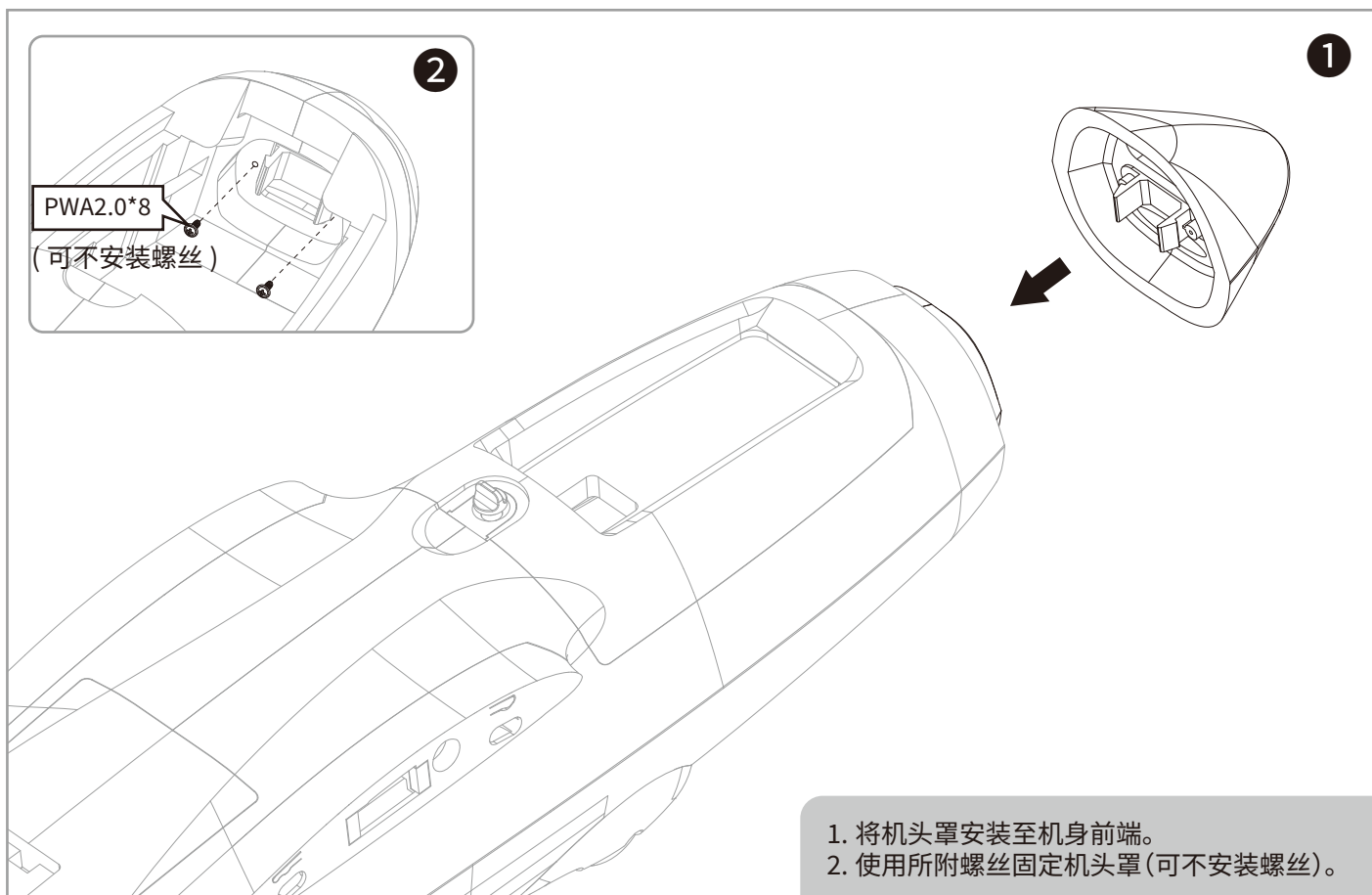

## 主翼安装

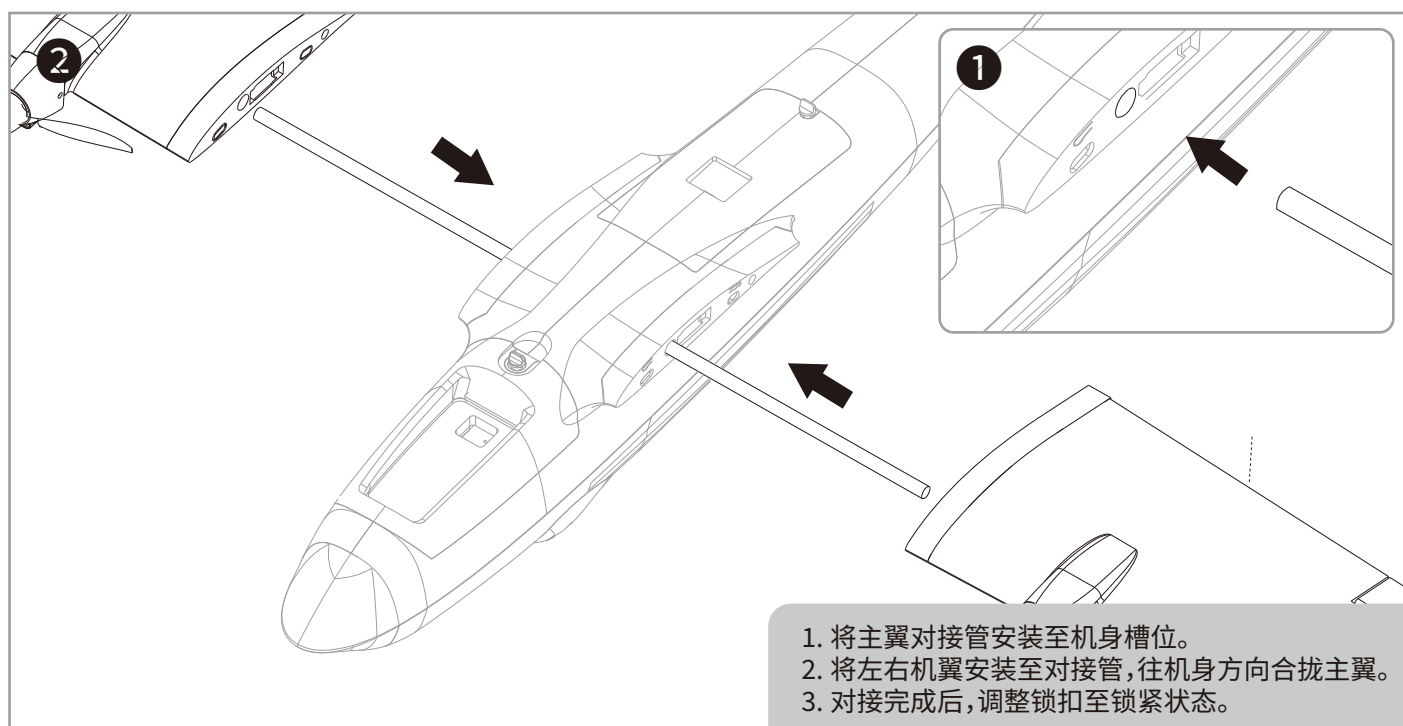

## 平尾安装

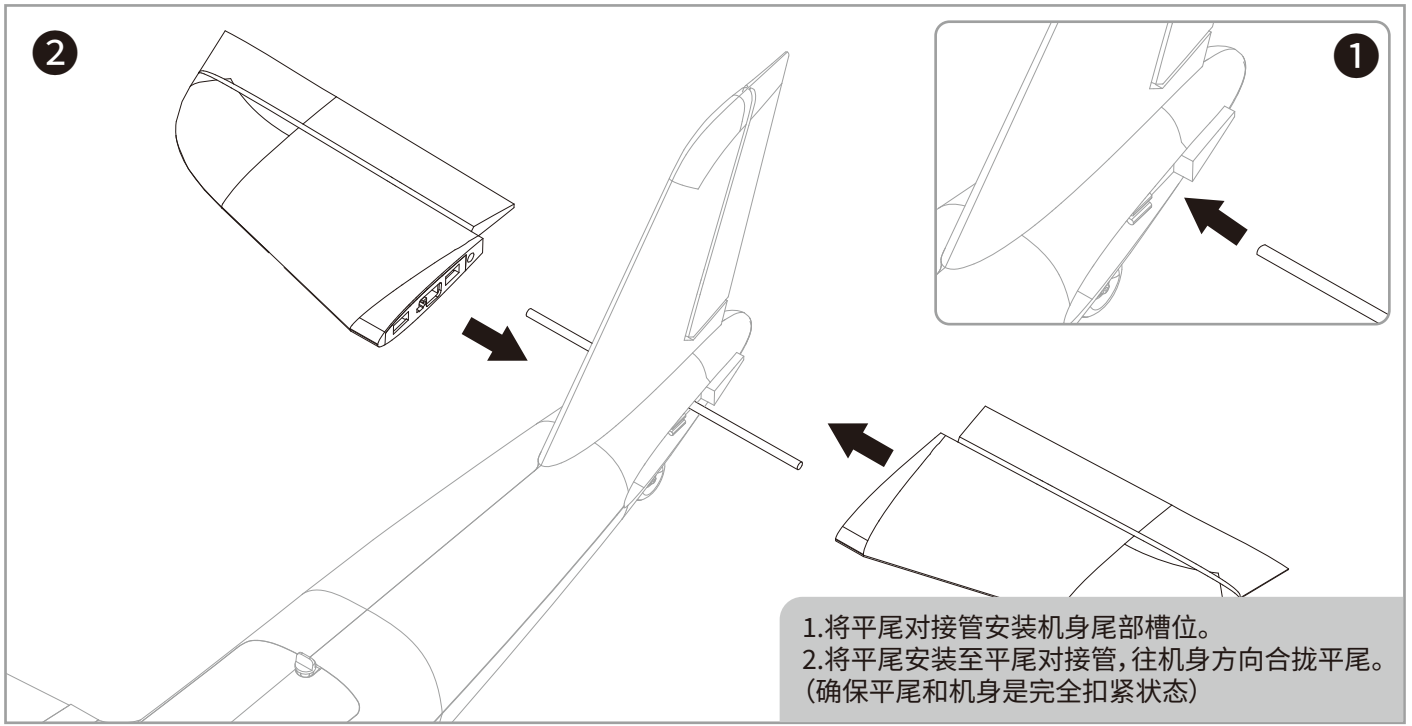

## 螺旋桨安装

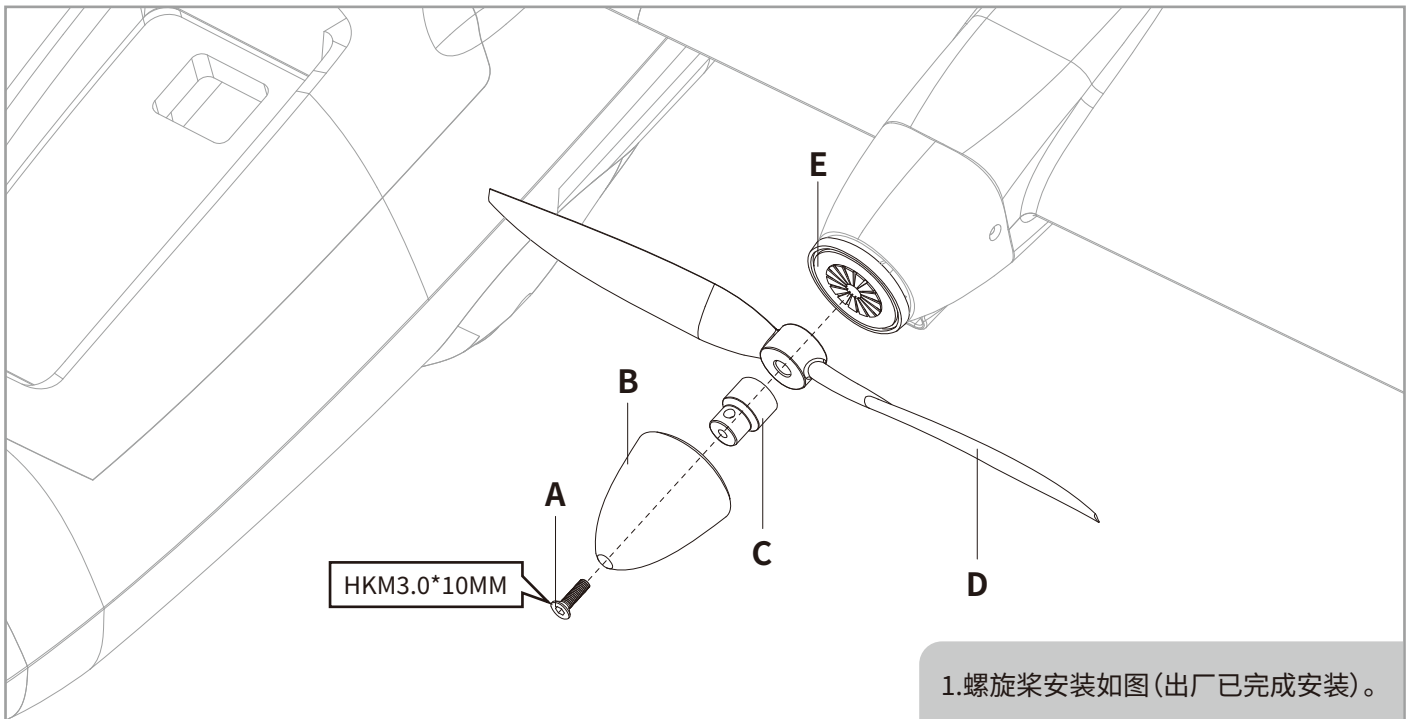

## 舵角摇臂安装

保证舵机为回中状态，将连接杆调整到合适位置。

图示是舵角和舵面摇臂的出厂设置。

首飞建议用出厂设置的舵角飞行。

### 副翼舵机钢丝安装孔位参考

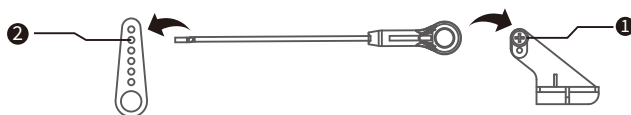

### 平尾舵机钢丝安装孔位参考

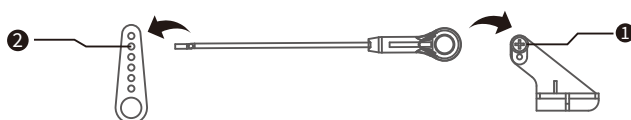

### 垂尾舵机钢丝安装孔位参考

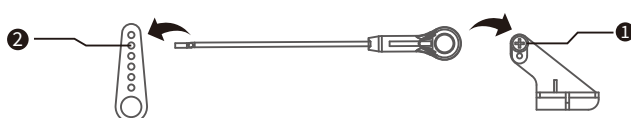

## 电池安装

1. 飞机通电前，首先请打开发射机电源，确认油门杆处于低位。

2. 将电池置于电池仓内，使用魔术贴固定电池。

3. 由于不同的电池厂家生产的电池重量有差异，需要调整电池的位置来平衡飞机的重心位置。

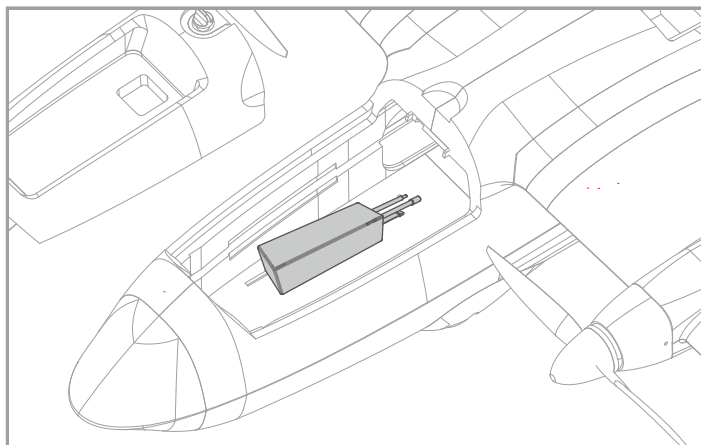

## 重心调整

**正确的重心,直接关系到飞行的成功与否,请参考下面的重心标示图来调整飞机的重心。**

— 您可以将电池向前、后移动来调整飞机的重心;如果通过移动电池无法调整到正确的重心位置,您还可以适当的使用一些其他材料来配重,使得飞机的重心处于正确的位置。

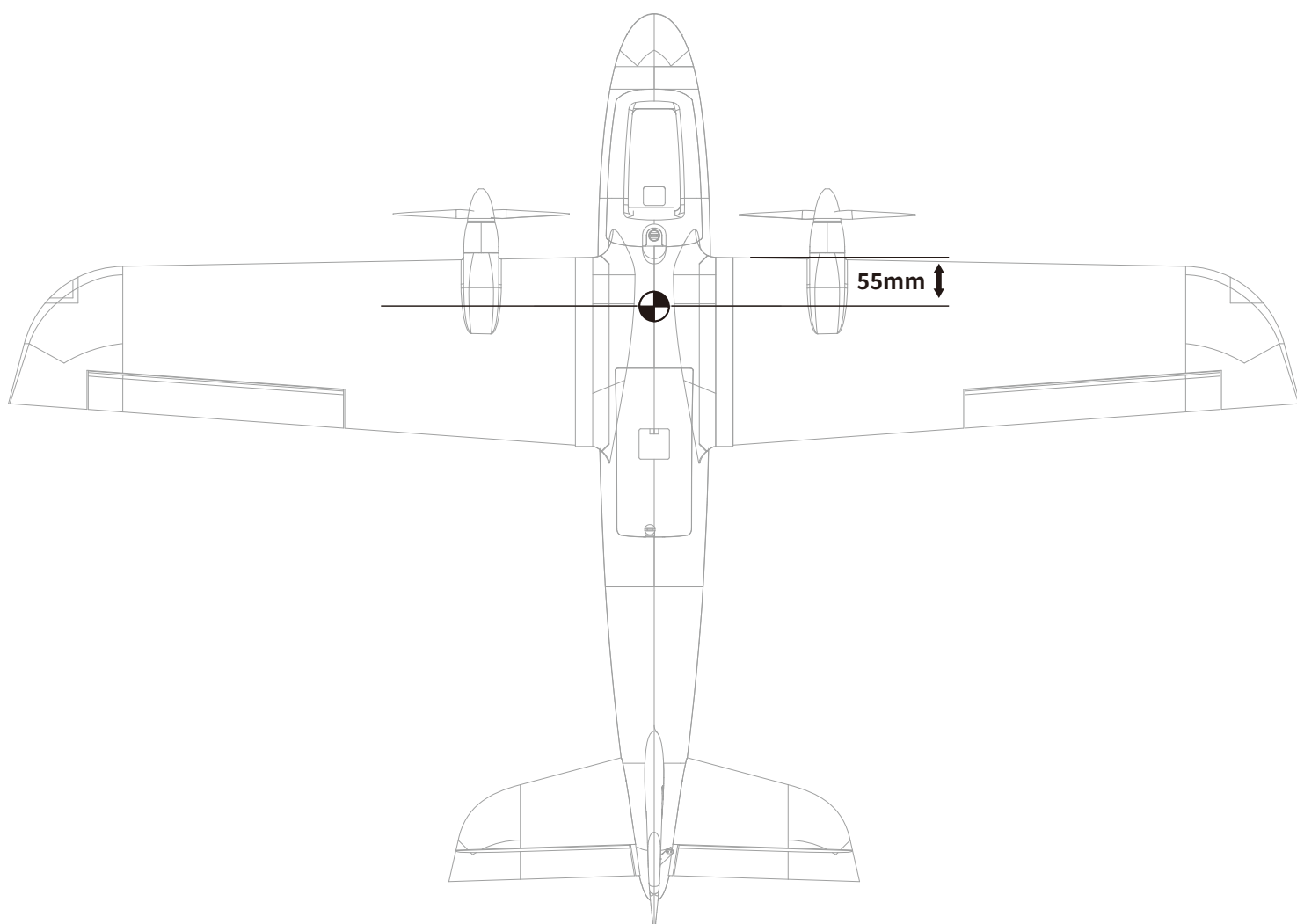

## \ 舵面测试 /

当您按照前面的步骤组装好飞机、调整好舵角摇臂后,在飞机起飞前,我们需要一块满电的电池连接到电调。用遥控器测试每个舵面的工作情况,检查是否正常!

副翼摇杆向左运动

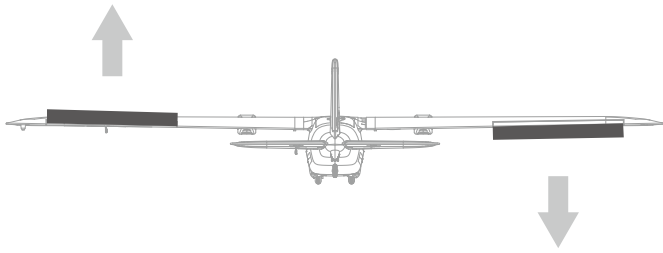

副翼摇杆向右运动

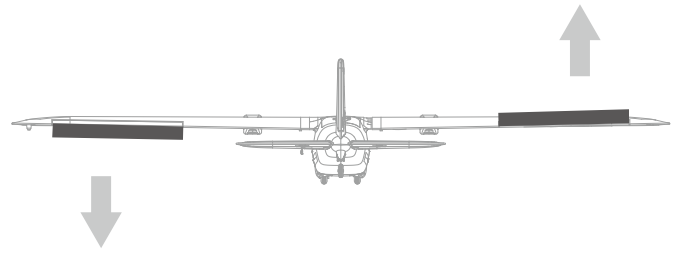

升降摇杆向下运动

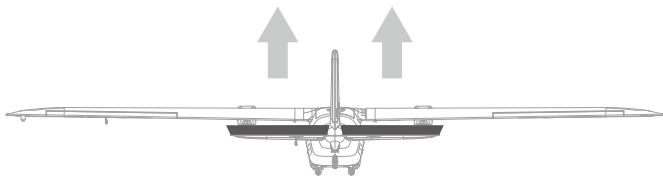

升降摇杆向上运动

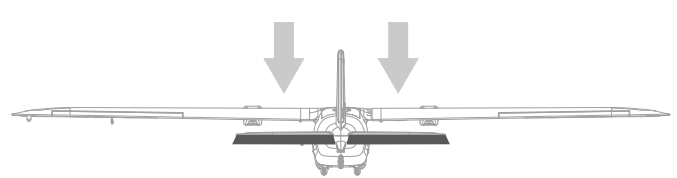

方向摇杆向左运动

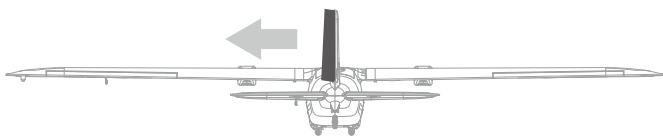

方向摇杆向右运动

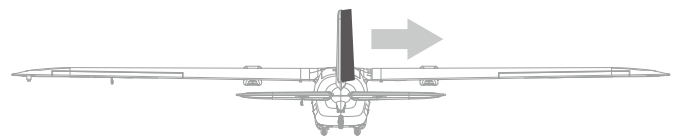

## 推荐舵面行程

根据我们的测试经验,我们认为按以下参数来设置大小舵量将更有助于飞行。小舵量飞机的操纵会显笨拙些,大舵量飞机的操纵会灵敏些,我们建议初次飞行使用大舵量起飞,然后视操纵习惯选用大舵量或小舵量飞行。

副翼

升降舵

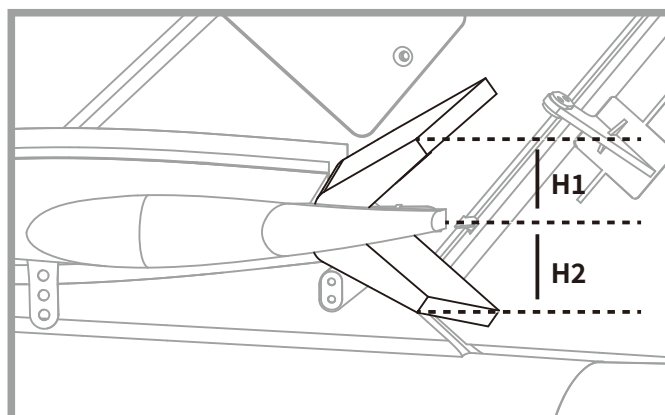
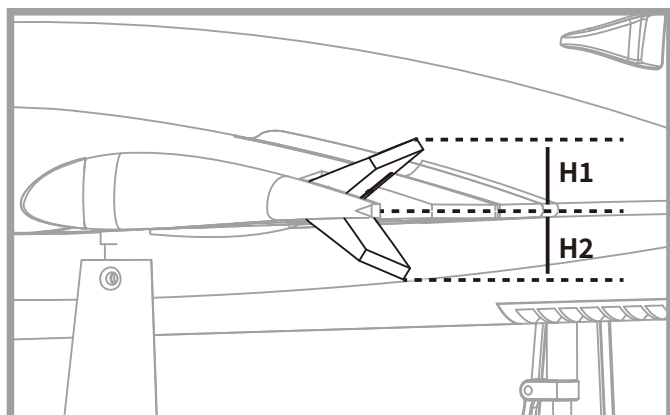

方向舵

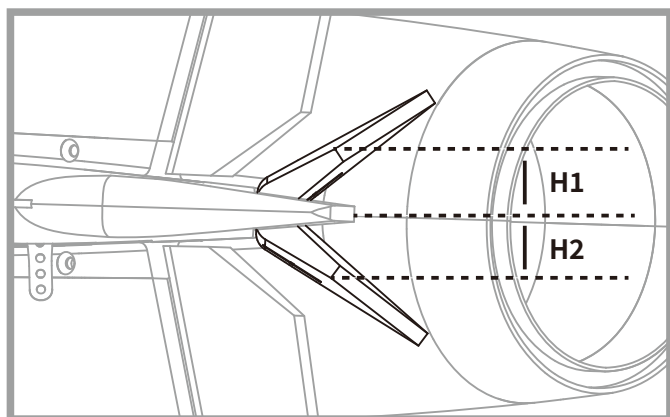

	副翼	升降舵	方向舵	襟翼下放
小舵量(H1/H2)	13mm/70%	10mm/70%	12mm/70%	/
大舵量(H1/H2)	18mm/100%	15mm/100%	17mm/100%	/

## \ 故障检修 /

问题	问题原因	解决方式
油门推杆无响应,但舵机有响应	—电调未连接电机 —油门通道反向	—降低油门推杆和油门微调设定 —反过来重新装油门通道
桨的噪音过大或者震动过大	—桨罩、桨、电机、电机架坏了 —桨或者桨罩的小部件松动了 —桨装反了	—更换损坏的配件 —把桨、桨夹和桨罩的小部件拧紧 —反过来重新装桨
飞行时间变短,飞机无力	—电池电量低 —桨装反了 —电池坏了	—重新给电池充电 —依照电池说明书更换新的电池
飞舵面不动,或者动作响应较慢	—舵面、舵角、连接杆、舵机坏了 —连接线坏了或者接头松了	—更换或者维修坏了的配件 —检查所有连接线,确保所有接头无松动现象
舵面反向	—遥控器发射机通道反向	—检查通道控制(舵面)方向,调试飞机舵面和遥控器的舵面控制杆
电机无力	—电机或电池坏了 —电调用了不合适的低压保护装置	—检查电池、发射机、接收机、电调、电机是否有损坏(如有,请及时更换) —立刻操控飞机降落,重新给电池充电
接收器的LED灯慢闪	—接收器低电量	—检查电调和接收器之间的连接 —检查舵机是否受损 —检查连接杆是否安装到位

## \ 配件列表 /

XFW004-01	机身	XF113X-12	螺旋桨(1对)
XFW004-02	主翼	XF113-15	舵机云台
XFW004-03	平尾	XFKV1400	2212-KV1400电机
XFW004-04	泡沫机头	XFESC40A-2	40A电调
XFW004-05	电池舱盖	XFPSE9P-50	9g金属数码正向舵机(50mm线长)
XFW004-06	FPV舱盖	XFPSE9P-400	9g金属数码正向舵机(400mm线长)
XFW004-07	设备舱盖	XFPSE9R-50	9g金属数码反向舵机(50mm线长)
XFW004-08	前轮组		
XFW004-09	后轮组		
XFW004-10	FPV机头		
XFW004-11	桨罩(1个)		
XFW004-12	主翼对接管		
XFW004-13	平尾对接管		
XFW004-14	连接杆		
XFW004-15	舵面摇臂组		
XFW004-16	LED航灯组		
XFW004B-17	贴纸-蓝色		
XFW004R-17	贴纸-红色		

# 空模无刷马达电子调速器(ESC)说明书

**尊敬的用户:**感谢您使用XFly 迅飞模型无刷电子调速器(ESC)。我们强烈建议您在使用本公司产品前,阅读使用手册。

XFly 迅飞模型有权不经通知变更其产品,包括其外观和性能参数及使用要求;对其产品是否适合特定用途不作任何保证、申明或承诺。不承担因第三方产品相关修改所造成的任何责任,XFly 迅飞模型亦不承担因应用或使用任何产品或电路而引起的任何责任,包括但不限于对附带损失或间接损失的赔偿责任。

## 一、主要特性:

无刷电机电子调速器主要特性:

- 无限制的转速支持:最高转速可无限制支持
- 循环菜单设置,操作简单方便
- 超平稳和精确的油门线性
- 安全通电功能:接通电源时无论遥控器的油门拉杆在任何位置均不会立即启动电机,防止电机突然旋转
- 遥控信号丢失保护
- 超温保护,110°C时自动降低功率一半输出,温度低于110°C时功率输出恢复
- 带舵能力强,超越目前市面所有电调
- 适合无刷电机的所有类型
- 支持编程功能

## 二、无刷电机电子调速器功能:

我们的电子调速器具有用户可编程功能,方便用户更具自身实际需求改变电子调速器的功能参数

1. 用户可编程刹车设置
2. 用户可编程电池类型(LiPo或NiMh/NiCd)
3. 用户可编程低压中止点设置
4. 用户可编程出厂默认设置恢复
5. 用户可编程马达进角设置(提高电调的效率和平稳性)
6. 用户可编程加速启动设置(针对精密变速箱和直升机应用)
7. 用户可编程直升机模式(针对直升机应用)
8. 用户可编程马达转向(顺时针/逆时针)
9. 用户可编程工作频率
10. 用户可编程低压中止类型(降低功率或立即关机)

## 三、调速器连接线说明:

(线连接用热缩管收缩使其绝缘,避免短路烧毁调速器)

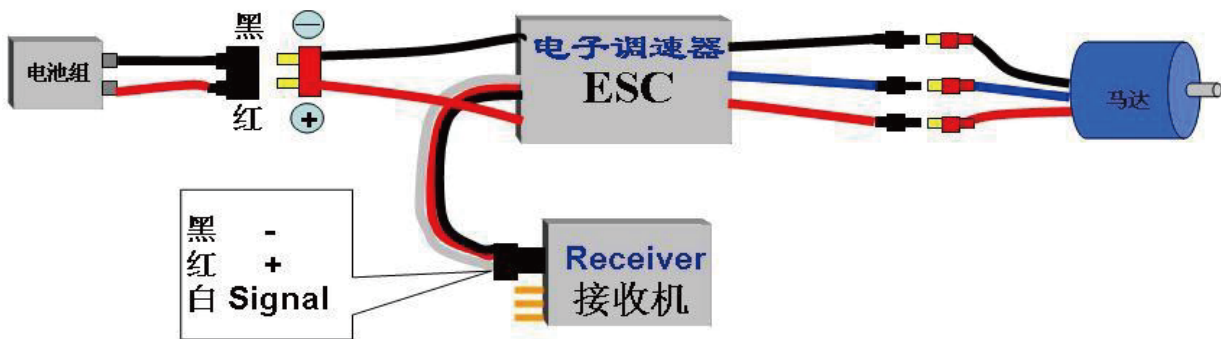

## 四、无刷电机电子调速器编程设置模式:

首先将遥控器油门拉杆推至最高位置,打开遥控器电源;(遥控器油门拉杆推至最高位置电调进入可设置模式;遥控器油门拉杆推至最低位置电调进入工作模式)

1) 将电池组连接到调速器,2秒后电机“滴滴”声响,表示电调进入设置模式,设置菜单是循环模式,即每一种功能对应一种音乐声调,每一种音乐声调连续奏响4次,在音乐奏响4次时间内将遥控器油门拉杆推至最低位置,这时电机会发出“滴”一声响,表示对应参数已存储,启动电机开始工作。

2) 重复以上操作,设置您所需要的各种功能

可用编程卡设定(注,可选配件);设置方法见编程卡说明书

### 1. 刹车:开/关

开—当油门处于最小位置工作时,螺旋桨立即停止

关—当油门处于最小位置工作时,螺旋桨缓慢停止

## 2. 电池类型：LiPo( 锂电 ) 或 NiCd / NiMh( 镍氢 / 镍隔 )

NiCad / NiMh—是对 NiCad / NiMh 电池设置低压保护点

Lipo—是对 Lipo 电池设置低压保护点，并在电池组内自动侦测电池的节数

备注：对 NiCad/NiMh 电池的选择会使电调自动将中止电压点设置为出厂默认值的 65%。如需要更改，可通过低压保护功能更改中止值。一旦 NiCad/NiMh 电池组被接通电源，电调便会读取其起始电压，此电压将被用做中止电压点的参考值。

## 3. 低压保护功能：

低 / 中 / 高

1) 对于 Li-xx 电池组：电池数量可被自动计算，除了确定电池类型外无需用户设置。电子调速器为低压保护提供了三档位选择：低 (2.8V) / 中 (3.0V) / 高 (3.2V)。例如：对于一个 11.1V/3 节电池的 Li-po 电池组来说，低压中止保护为 8.4V 低 / 9.0V 中 / 9.6V 高

2) 对于 Ni-xx 电池组：低 / 中 / 高中止电压是电池组起始电压的 60%

恢复出厂默认设置

将电子调速器设定为出厂默认状态：

1) 刹车：关

2) 电池类型：有自动侦测功能的 Lipo 电池

3) 低压中止点：中 (3.0V/60%)

4) 马达进角设置：自动

5) 加速度启动设置：柔和

6) 直升机模式设置：关

7) 工作频率设置：8kHz

8) 低压中止类型：减小功率

5. 马达进角设置：自动 / 低 / 高

自动 -- 电调自动侦测最适宜的马达进角设定

低 (7-22 度) -- 应用于大多数的内转子马达

高 (22-30 度) -- 应用于 6 对或更多极性外转子的马达

大多数情况下，自动进角适用于所有类型的马达，但为了提高效率，我们建议对 2 极马达使用低进角设置（一般的内转子），6 极和 6 级以上（一般的外转子）马达使用高进角。对于较高的速度，可以设定高进角。有些马达需要不同的进角设置，所以如果您无法确定，我们建议您采用制造商推荐的设置或使用自动侦测进角设置。

备注：修改马达的进角设置后，请先在地面上运行您的马达

6. 加速启动设置：( 提供带有线性油门响应的快速加速启动 )

超柔和启动：从开始到最大速度油门响应滞后 1.5 秒，目的是为了防止精密齿轮或其他传动装置在瞬时负载下脱落；建议此设置用于装有变速箱的固定翼模型或直升机。

柔和启动：从开始到最大速度油门响应滞后 1 秒，建议此设置用于装有变速箱的固定翼模型或直升机

加速启动：从开始到最大速度油门响应无滞后，建议对装有直接驱动的固定翼模型使用

7. 直升机模式 ( 针对直升机应用 )

直升机关闭

直升机 1：从开始到最大速度油门响应滞后 5 秒，若启动后关闭油门，再次启动时则均以普通模式启动

直升机 2：从开始到最大速度油门响应滞后 15 秒，若启动后若关闭油门，再次启动时则均以普通模式启动

备注：一旦工作在直升机模式，无论电调之前有怎样的设置，电调刹车和低压保护类型设置都将分别被自动重新设置为无刹车和减小功率模式

小功率模式

8. 马达转向：正 / 反转

大多数情况下，马达正 / 反转一般是通过交换任意两条马达线来实现的。当马达线已被直接焊接在电调上时，可以通过改变电调上的设置值使马达改变转向。

9. 工作频率：8kHz / 16kHz

8kHz—为 2 极对马达设置的工作频率，比如内转子

16kHz—为 2 个以上极对的马达设置的工作频率，比如外转子

虽然工作频率 16kHz 能给我们的固定翼或直升机提供更劲暴的动力，但由于 16kHz 所产生的较高 RF 噪音，所以默认设置为 8kHz

10. 低压保护类型：减小功率 / 立即停止

减小功率：当达到预设的低压保护临界值时，电调会立刻减小马达的输出功率（推荐）

立即停止：当达到预设的低压保护临界值时，电调会立刻关断输出马达功率

## 五、编程菜单顺序与说明

油门行程设置			
●●●●●●●●		全油门行程	OK
刹车(开.关)			
_ * _ * _ * _ *		开←→关	OK
电池类型			
~ ~ ~ ~		NiCad	OK
~ ~ ~ ~		LiPo	OK
电池低压保护			
* _ * * _ * * _ * * _ *		低	OK
* _ * * _ * * _ * * _ *		中	OK
* _ * * _ * * _ * * _ *		高	OK
恢复出厂默认设置			
— — — —		出厂默认	OK
进角			
- - - -		自动(7—30°)	OK
-- -- -- --		低(7--22°)	OK
--- --- --- ---		高(22--30°)	OK

马达启动(加速度)			
VV VV VV VV		超柔和启动	OK
V V V V		柔和启动	OK
VVV VVV VVV VVV		加速启动	OK
直升机模式			
-*- *-* -*- *-*		直升机(关)	OK
-***- -***- -***- -***-		直升机(1)	OK
-****- -****- -****- -****-		直升机(2)	OK
马达转向(正.反)			
W W W W		正←→反	OK
工作频率			
// // // //		频率(8K)	OK
\\ \\ \\ \\		频率(16K)	OK
马达低压停止方式			
- - - -		降低功	OK
-- -- -- --		关断功率	OK
- - - -			

## 六、使用您的新电子调速器

错误的极性或短路都会损坏您的电子调速器，所以您必须在连接电池组之前，仔细检查所有插头的极性是否正确以及安装是否牢固。

### ● 警报音：

XFly 迅飞模型电调中，设置了警报音来显示通电后的异常情况

1. 上电后不能进入工作模式，说明您还没有设置油门行程
2. 持续的滴滴响，说明油门拉杆不在最小位置上
3. 滴的一声响后有一秒钟的停顿，说明电池组电压不在可接受范围之内（一旦电池被连接，电调便会自动检查并检验电池电压）
4. 滴的一声响后有短暂的停顿，说明电调不能侦测到来自接收机的正常油门信号

### ● XFly 迅飞模型电调内置智能安全功能模块

1. 过热保护：当 ESC 的温度超过 110 度时，ESC 会减小输出功率，使其冷却
2. 丢失油门信号保护：当电调侦测到油门信号丢失 2 秒钟后，便自动减小对马达的输出功率，油门信号接着又丢失超过 2 秒钟，电调会自动关断马达。如果在降低马达的输出功率过程中，油门信号恢复，即可立即恢复油门控制

### ● 第一次接通电调并设置油门行程

XFly 迅飞模型电调的特点是根据不同的发射机可设置最佳油门行程，电调能够通过发射机的整个油门行程来获取最平稳的油门线性。此操作只能进行一次，目的是让电调获取并记忆发射机的油门输出信号，只有在您更换发射机时才需重复此操作。

1. 打开发射机并将油门拉杆推到最大位置
2. 连接电池，接收机，马达与电调，等待 2 秒左右，马达会“滴滴”两声响，这时把油门拉杆拉到最小，马达也会“滴滴”两声响；这时表明电调已获取您的发射机油门信号范围

此时油门行程已被校准，您的电调现已准备完成，可以进入工作状态

### ● 电调的正常启动程序：

1. 接通发射机并将油门拉杆拉到最小位置。
  2. 将电池组连接到电调上
- 当电调第一次通电时，会连续发出两组可听见的声音，说明电调进入工作状态

○ 第一组声音表示与电调相连接的 Lipo 电池组中电池的数量（三声滴滴响表示有三节电池，四声滴滴响表示有四节电池）

○ 第二组声音表示刹车的状态（一声滴滴响表示刹车为开，二声滴滴响表示刹车为关）

○ 电调现已准备好使用

### ● 一般安全防范

● 检验无线电接收装置上的正确设置，第一次测试 ESC 和马达时不要在马达上安装螺旋桨或传动小齿轮。只有当您确认了无线电接收装置被设置正确后，方能安装螺旋桨或传动小齿轮。

● 不要使用裂开或被刺破的蓄电池组电池

- 不要使用会变得过热的电池组
- 不要使用短路电池或马达接线端
- 电缆绝缘要用正确的绝缘材料
- 使用正确的电缆连接器
- 电池或伺服系统的数量不要超过电调的规定
- 错误的电池极性会损坏电调

● 问题解答

出现的问题	可能的原因	解决方法
接通 ESC 后有自动检测电池节数声音, 但马达不能启动	ESC 没有油门行程设置	对 ESC 进行油门行程设置
马达不工作, 链接电池后马达未发声, 伺服系统也未运行	电池组与 ESC 之间接触不良 没接通电源 焊接不牢固 (接头易断) 电池电缆极性错误 ESC 信号线与接收机连接极位相反 ESC 有问题	清理连接器终端或替换连接器 用刚充满电的电池组替换 再次焊接电缆连接 检查并确认电缆极性 检查连接在 ESC 上的信号线以确保处于正确极性 更换 ESC
马达不工作, 连接电池后马达未发出音乐声, 但伺服系统在运行 接通 ESC 后马达不工作, 发出警报音 (两声滴滴响后有短暂停顿)	ESC 与马达之间接触不良 马达线圈被烧 焊接不牢固 (接头易断) 电池组电压不在可接受范围内	检查连接器终端或替换连接器 替换马达 再次焊接电缆 联接 更换为刚充满电的电池组 检查电池组电压
接通 ESC 后马达不工作, 发出警报音 (一声滴滴响后有短暂停顿)	ESC 不能侦测到来自接收机的正常信号	检查并确认 ESC 信号线是否连接在接收机油门通道 检查发射器和接收机以确认有信号输出
接通 ESC 后马达不工作, 发出警报音 (持续地滴滴响)	通电后油门拉杆不在最小位置	将油门拉杆移至最小位置
接通 ESC 后马达不工作, ESC 发出两声长响之后, 有两声短暂的滴滴响	被颠倒的油门通道导致 ESC 进入程序设计模式	进入发射器上的伺服系统 倒转菜单并倒转油门通道
马达反向运行	ESC 与马达之间错误的电缆连接	交换 ESC 与马达之间三条电缆连接中的任意两条或者通过 ESC 程序设计模式进入马达旋转功能并改变预设参。
飞行过程中, 马达停止运行	丢失了油门信号	检查无线电接收装置是否操作得当。 检查 ESC 和接收机信号线路及发送频道和 ESC 信号线之间确保有足够的隔离来防止干扰 在 ESC 的信号线上安装一个磁环

调速器产品规格

型号	持续输出电流	瞬时输出电流 (10秒)	电池节数 镍氢\锂电	重量 (g)	BEC 输出	体积 mm (宽*长*高)	参数编程功能
LCA01300601 (BEC)	6A	8A	5-8 NC \ 2-3 Lipo	11	5V / 1A	19x30x1	有
LCA01301501 (BEC)	15A	20A	5-8 NC \ 2-3 Lipo	12	5V / 2A	22x22x1.5	有
LCA01702001 (BEC)	20A	30A	5-12 NC \ 2-4 Lipo	35	5V / 2A	24X42X2	有
LCA01703001 (BEC)	30A	35A	5-12 NC \ 2-4 Lipo	35	5V / 2A	24X42X2	有
LCA01704001 (SBEC)	40A	60A	5-12NC \ 2-4 Lipo	55	5V / 3A	26X52X2	有
LCA02507001 (SBEC)	70A	90A	5-18NC \ 2-6 Lipo	65	5V / 5A	32x64x2	有

注：OPTO 调速器与SBEC 调速器说明

1)OPTO 调速器没有内置BEC, 工作时需单独给舵机, 接收机供电

2) S BEC 调速器,给舵机供电是开关电源模式, 输出电压5V, 带4A 负载(舵机),瞬间2 秒可达8A

注意:在飞行过程中若电机突然停转, 请立即将油门拉杆推到最低位置, 再推起油门, 电机将重新启动, 将油门控制在较小位置, 立即降落您的模型。

以下几种情况会在运行中关断电机:

1)电池电压降低至设定的低压保护电压, 并且设定低压保护方式为关断方式。

2) 遥控信号丢失采用以下方法避免上述:

1. 使用充满的电池飞行;正确设置低压保护电压;低压保护方式设为降低功率方式(目前出厂设定模式)。若在飞行中发现功率降低, 请降落您的模型。

2. 请勿在电调外包裹任何物品;将电调安装在可通风降温的位置。

3. 控制您的模型在遥控器遥控范围内飞行;注意遥控器电池电压, 若电压降低较多, 请降落您的模型。



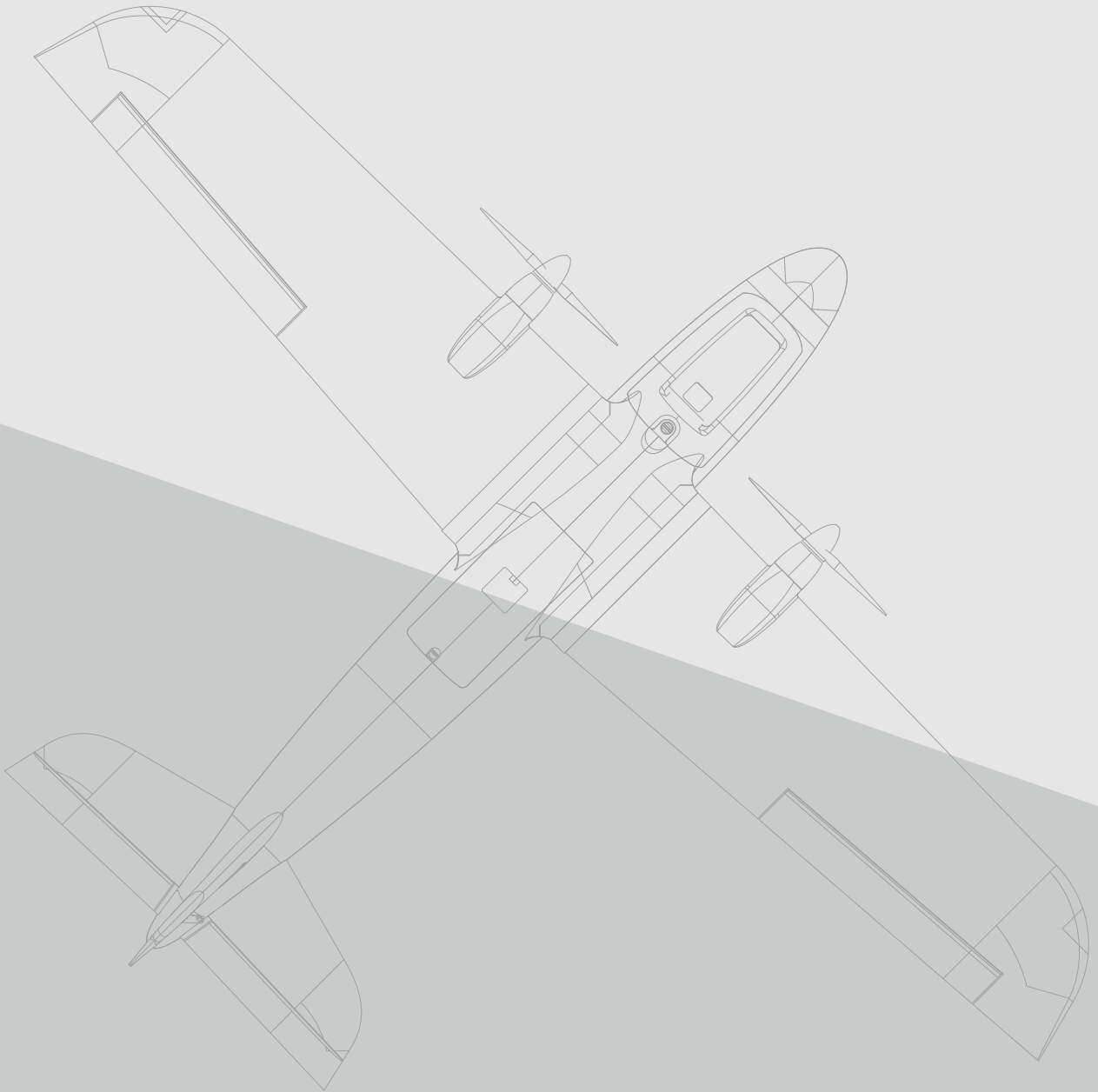

**XFLY-MODEL**



Dongguan Xfly-Model Technology Co., Ltd  
URL: <http://www.xfly-model.com/>  
E-Mail: [support@xfly-model.com](mailto:support@xfly-model.com)

东莞市迅飞航空科技有限公司  
网址: <http://www.xfly-model.com/>  
邮箱: [support@xfly-model.com](mailto:support@xfly-model.com)