

ЯК-130 *70mm EDF JET*

User Manual



EN 1-11

中 12-22



Thanks for your purchasing our 70mm EDF Yak130. designed by Yakovlev Design Bureau, Yak130 is the most advanced trainer in Russia, its good design and excellent performance by the Russian Air Force and foreign users of all ages!

This jet used EPO material, reduced by the real jet size, its own high scale shape. The same as the real jet, Yak130 have a larger wing area and wing-fuselage structure, no matter high-speed or low-speed, its fly excellent, and landing is easier and lighter. Main wing still use the screw to fix, easy to assemble/disassemble, and easy to carry. Fiberglass tube is in the main wing, its make the main wing stronger. We used 8pcs servos for this jet, include aileron, flap, elevator, rudder, and nose steering. Retract landing gear is suited for different take-off/landing condition, flight resistance is smaller in air, more beautiful.

⚠ NOTE: This is not a toy. Not for children under 14 years. Young people under the age of 14 should only be permitted to operate this model under the instruction and supervision of an adult. Please keep these instructions for further reference after completing model assembly.

Note:

1. This is not a toy! Operator should have a certain experience, beginners should operate under the guidance of professional players.
2. Before install, please read through the instructions carefully and operate strictly under instructions.
3. Cause of wrong operation, Freewing and its vendors will not be held responsible for any losses.
4. Model planes' players must be on the age of 14 years old.
5. This plane used the EPO material with surface spray paint, don't use chemical to clean, otherwise it will damage.
6. You should be careful to avoid flying in areas such as public places, high-voltage-intensive areas, near the highway, near the airport or any other place where laws and regulation clearly prohibit.
7. You cannot fly in bad weather conditions such as thunderstorms, snows....
8. Model plane's battery, don't allowed to put in everywhere. Storage must ensure that there is no inflammable and explosive materials in the round of 2M range.
9. Damaged or scrap battery should be properly recycled, it can't discard to avoid spontaneous combustion and fire.
10. In flying field, the waste after flying should be properly handled, it can't be abandoned or burned.
11. In any case, you must ensure that the throttle is in the low position and transmitter switch on, then it can connect the lipo-battery in aircraft.
12. Do not try to take planes by hand when flying or slow landing process. You must wait for landing stop, then carry it.

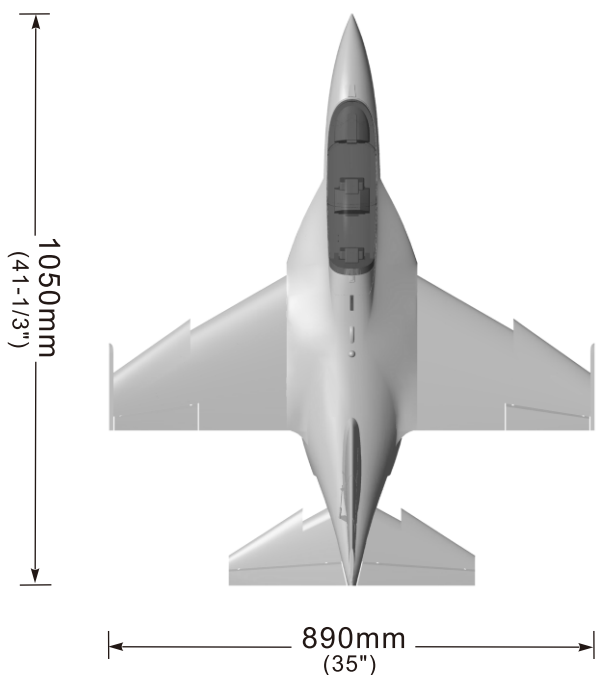

Note: The parameters in here are derived from test result using our accessories. If use other accessories, the test result will be different. Any problem since of using other accessories, we are not able to provide technical support.

Standard Version

Material : EPO
 Servo: 9g servo ×8pcs
 Motor: o/r BL 2849-2850KV
 ESC: 60A
 Ducted fan: 70mm 12-blade plastic
 Weight: 1210g (w/o Battery)
 Battery advise: 4S 14.8V 3300mAh

- retract
- pilot
- 6CH or 6CH plus Radio

Upgrade Version

Material : EPO
 Servo: 9g MG servo ×8pcs
 Motor: o/r BL 2849-2200KV
 ESC: 60A
 Ducted fan: 70mm 6-blade plastic
 Weight: 1280g (w/o Battery)
 Battery advise: 6S 22.2V 3300mAh

- retract
- pilot
- 6CH or 6CH plus Radio

Package list

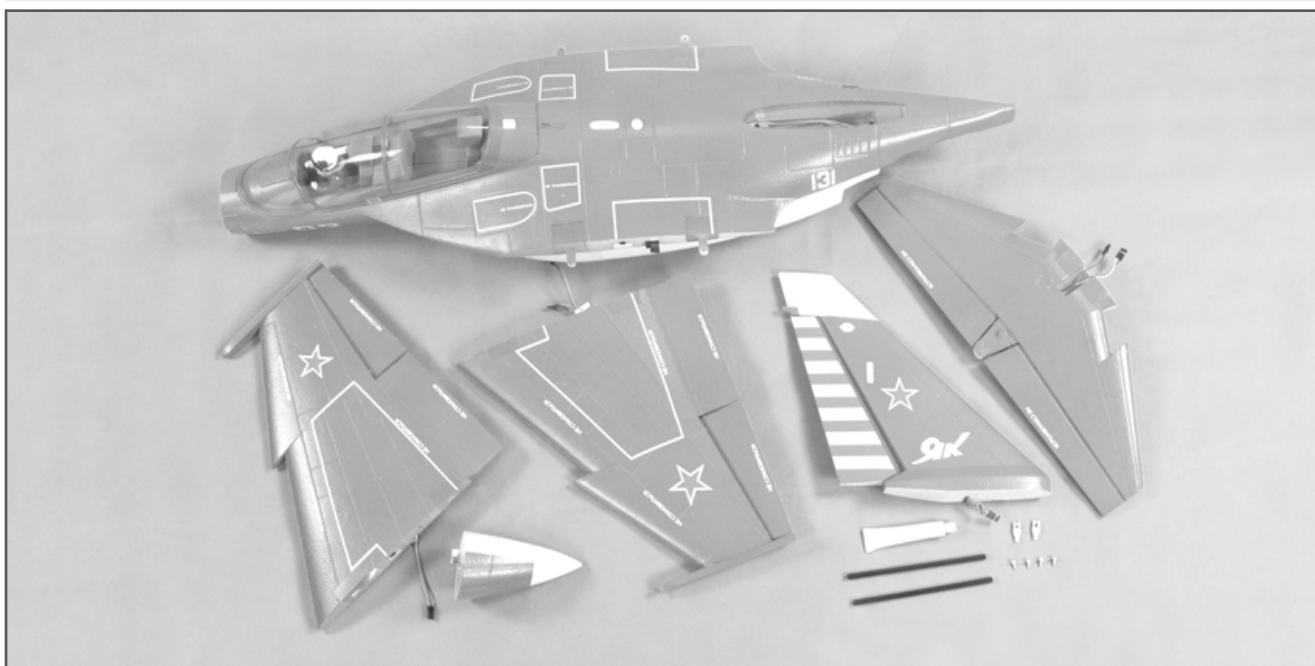

Different equipment include different spareparts. Please refer to the following contents to check your sparepart list.

No.	Name	PNP	KIT Plus	Airframe
1	Fuselage	Pre-installed all electronic parts	Pre-installed servo	No electronic equipment
2	Main wing set	Pre-installed all electronic parts	Pre-installed servo	No electronic equipment
3	Tail wing set	Pre-installed all electronic parts	Pre-installed servo	No electronic equipment
4	Nose cone	✓	✓	✓
5	Manual	✓	✓	✓

No.	Name	PNP	KIT Plus	Airframe
1	AB Glue	✓	✓	✓
2	Screw bag	✓	✓	✓
3	Carbon fiber tube	✓	✓	✓
4	Pushrod			✓
5	Plastic cover		✓	✓

Note: There is a EPO glue on package, please use it to glue. Glue should be spread evenly, and wait for 90 seconds. Then install on, its best glue condition.

Install elevator servo

1. Use glue to fix the servo and servo arm on the elevator.
(Refer to the right photo)
2. After glue solidify, connect the pushrod to servo and servo arm.
3. Use glue to attach on the servo plastic cover.

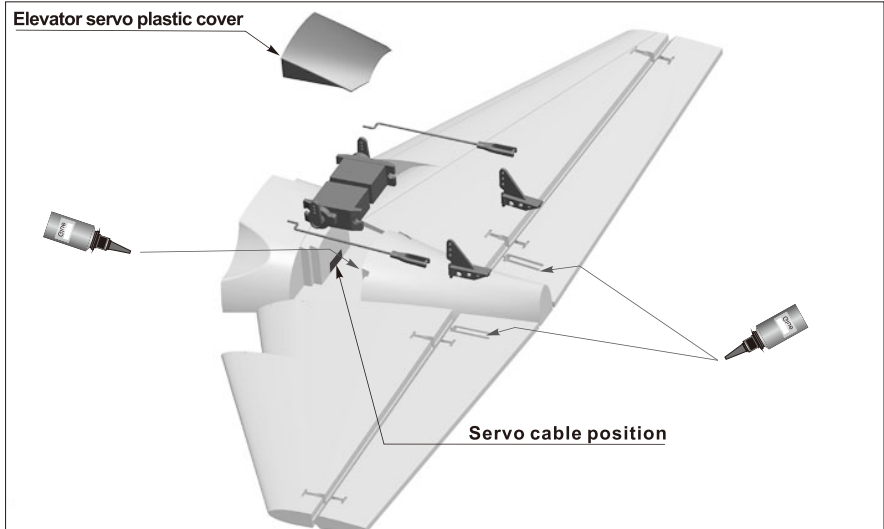

Install rudder servo

1. Use glue to fix the servo and servo arm on the rudder.
(Refer to the right photo.)
2. Press the servo cable on the servo cable trough.
3. After glue solidify, connect the pushrod to servo and servo arm.

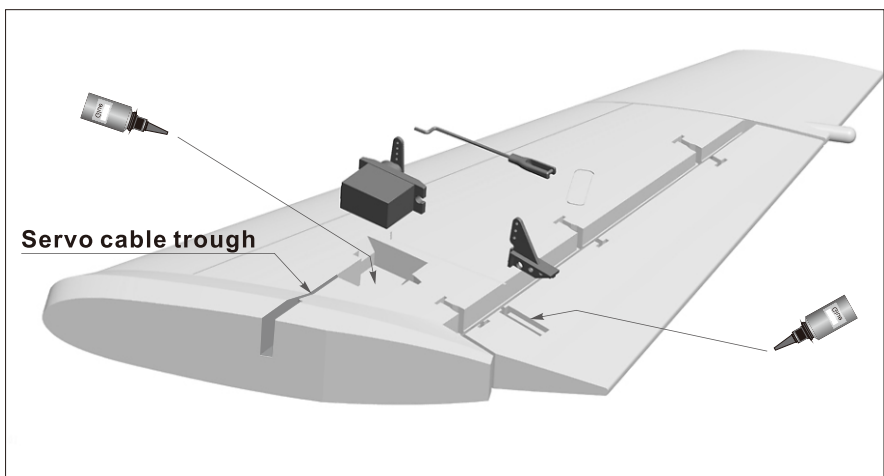

Install main wing servo

1. Use glue to fix the servo and servo arm on the main wing.
(Refer to the right photo.)
2. Press the servo cable on the servo cable trough.
3. After glue solidify, connect the pushrod to servo and servo arm.

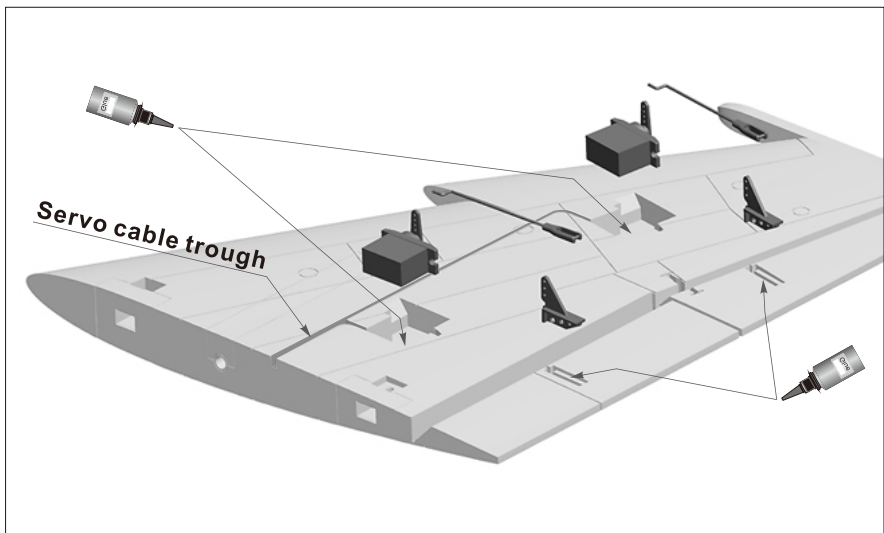

Aileron pushrod size

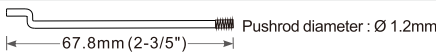

Aileron pushrod mounting hole

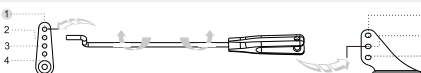

Flap pushrod size

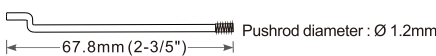

Flap pushrod mounting hole

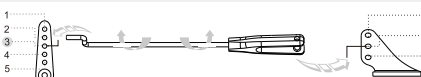

Rudder pushrod size

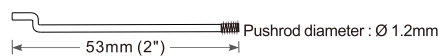

Rudder pushrod mounting hole

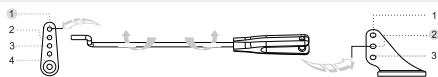

Elevator pushrod size

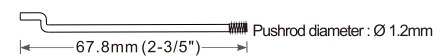

Elevator pushrod mounting hole

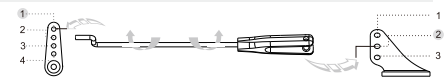

Note: There is a EPO glue on package, please use it to glue. Glue should be spread evenly, and wait for 90 seconds. Then install on, its best glue condition.

Install elevator

1. Connect the elevator servo cable and extension line in fuselage.
2. Use glue to fix the elevator on the fuselage.
(The arrow indicated position as the right photo shown, spread the glue evenly.)

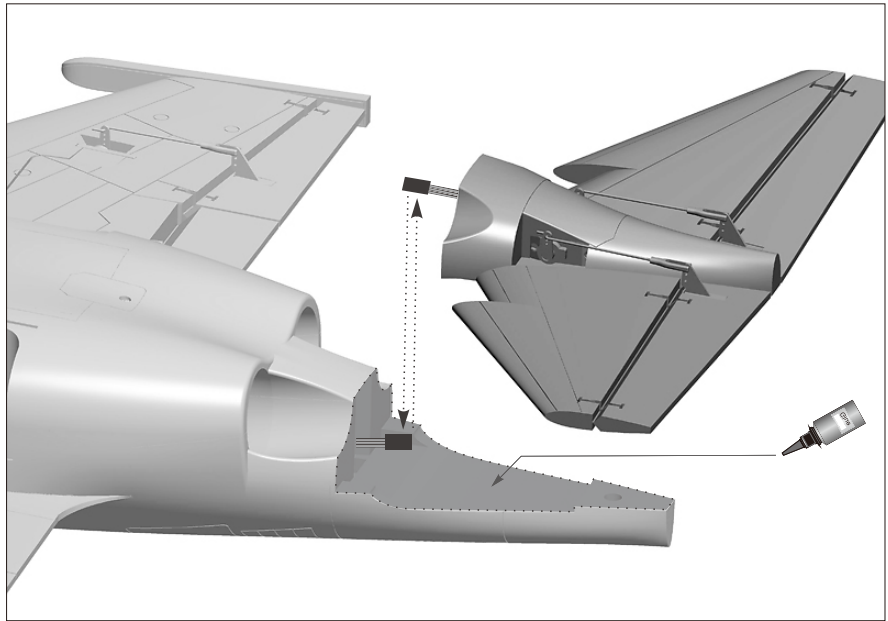

Install main wing

1. Spread the glue evenly on the tubes.
2. Insert one side of tube in the main wing and keep 60mm in outside.
3. Insert left/right wing on the left/right bolt of fuselage.
4. At last use 4pcs screws to fix.

Glassfiber tube specification:

Ø6×150mm 2pcs

Screw specification:

PWA3×8mm 4pcs

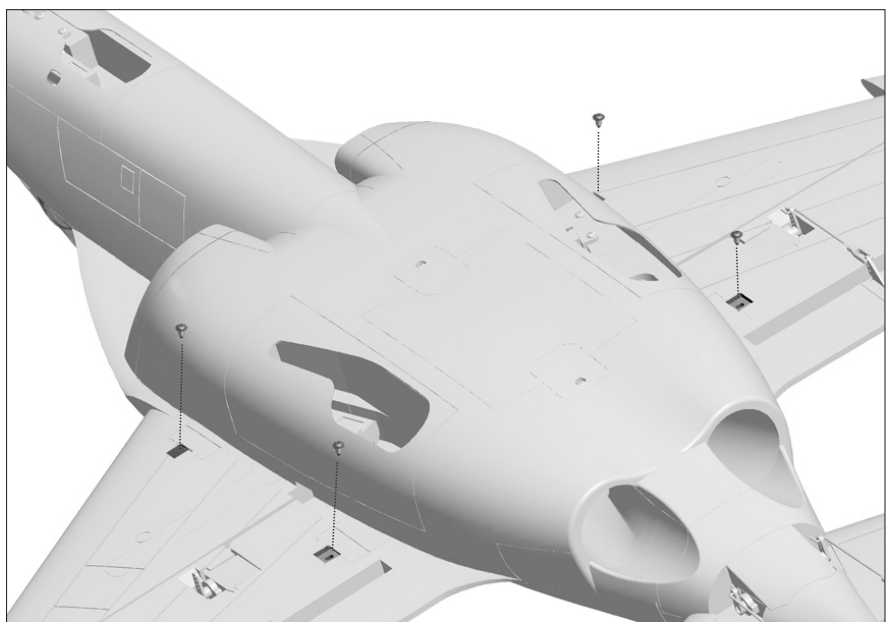
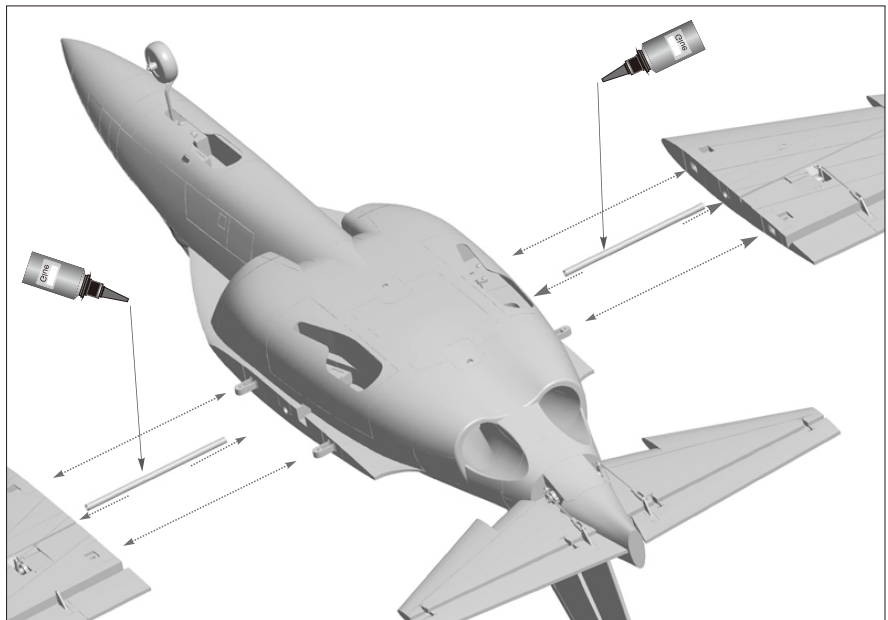

Note: There is a EPO glue on package, please use it to glue. Glue should be spread evenly, and wait for 90 seconds. Then install on, its best glue condition.

Install rudder

1. Connect the rudder servo cable with extension line of rudder servo.
2. Use glue to fix the rudder on the fuselage.

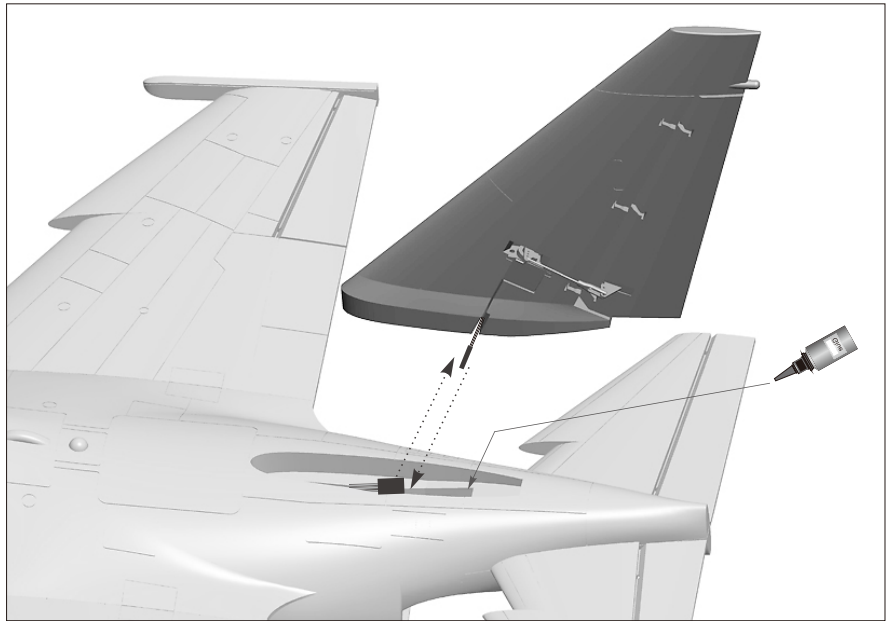

Install nose cone

1. As the right photo shown, use glue to fix the nose cone on fuselage.

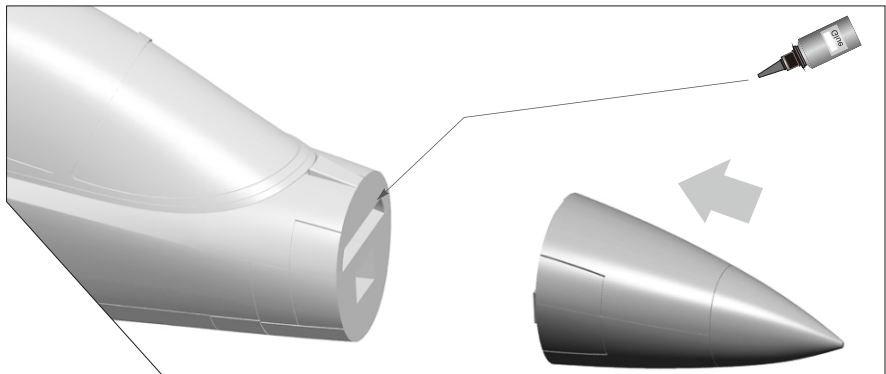

Install landing gear

Install nose landing gear

1. Put the L-shape steering arm (G), rotating arm (C) on the top of nose gear metal wire (H).
2. Make sure the flat position, screw hole position, use screw (F) to fix L-shape steering arm (G).
3. Put the E-buckle (B) in the top groove of nose gear metal wire (H), to avoid the nose gear metal wire (H) fall off from rotating arm (C).
4. Put the landing gear steering control ring (E) to metal wire (D), screw metal wire (D) to the L-shape steering arm (G).
5. Put the wheel I, wheel chocks (J) on the end of nose gear metal wire (H), then fix it by jimi screw (K).
6. At last install the assembled rotating arm (C) on the retractable controller and use screw (A) to fix.

sparepart list:

- A - Screw
- B - E-buckle $\varnothing 2.0\text{mm}$
- C - Rotating arm
- D - Metal wire
- E - Landing gear steering control ring
- F - JIMI Screw $M3 \times 3\text{mm}$
- G - L-shape steering arm
- H - Nose landing gear main metal wire
- I - Wheel $\varnothing 40 \times 15\text{mm}$ (EVA)
- J - Wheel shock
- K - JIMI Screw $M3 \times 3\text{mm}$

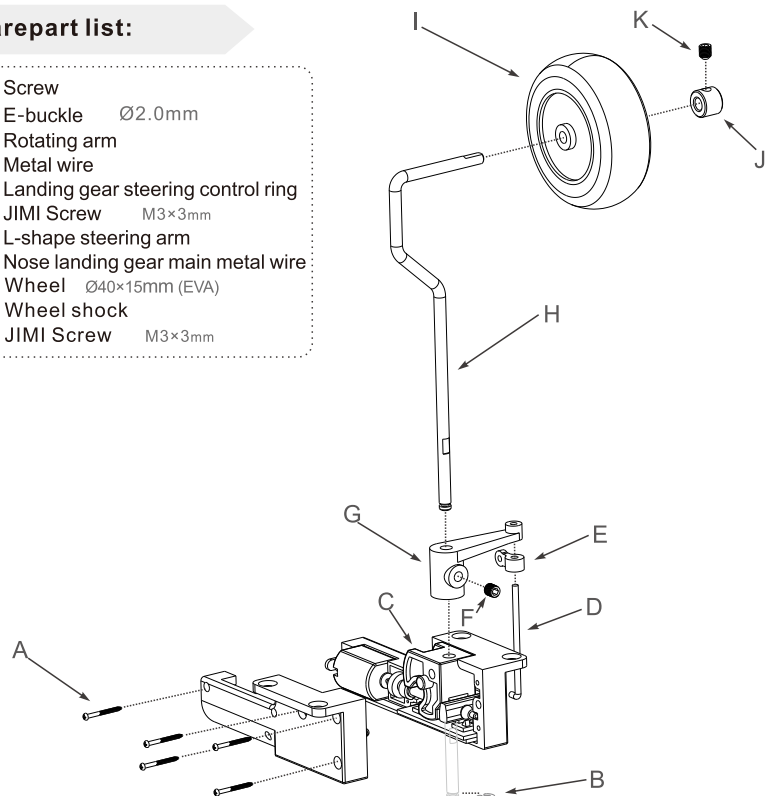

Install Fuselage

Install nose landing gear

1. Use the screw to fix assembled nose landing gear on the nose gear mount.
2. Use glue to fix the nose cabin door.

Screw specification:
PWA3×12mm 4pcs

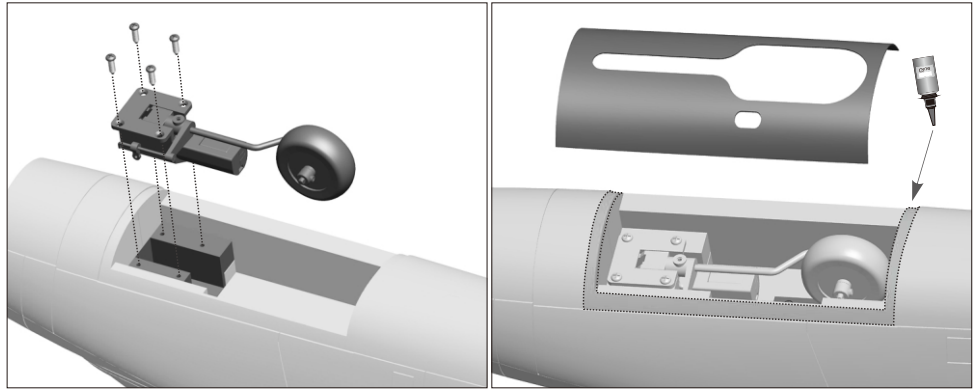

Installing the servo of nose landing gear steering

- A - 9g servo
- B - Screw PWA2×8mm
- C - Servo pushrod
- D - Landing gear steering control ring

1. Install the servo (A) on the wood piece, use screw (B) to fix the servo.
2. Buckle one side of servo pushrod (C) in the landing gear steering control ring (D). Insert the other side through U-shape servo arm, adjust its depth to center the nose wheel.

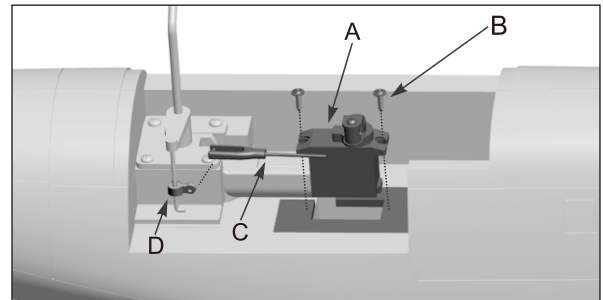
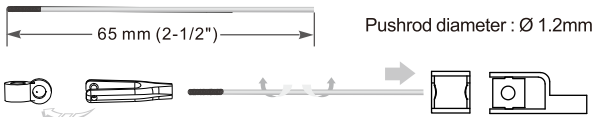

Install rear landing gear

Rear landing gear sparepart list:

- A - Retract drive
- B - JIMI Screw M3×3mm (3pcs)
- C - Metal wire
- D - Wheel Ø50×15mm (EVA)
- E - Wheel shock
- F - Screw PWA3×8mm (4pcs)
- G - Rear landing gear fixed mount
- H - Rear landing gear
- I - Rear landing gear cover

1. Insert the rear landing gear metal wire (C) to the retract controller (A), and use jimmy screw (B) to fix.
2. Put the wheel (D), wheel shock (E) on the end of rear landing gear metal wire (C), and use jimmy screw (B) to fix.
3. Install the assembled rear landing gear (H) on the rear gear mount (G), and use screw (F) to fix.
4. Repeat the above steps to install another rear landing gear.
5. After left/right rear landing gear installed, retract back the landing gear.
6. Use glue to fix the rear landing gear plastic cover.

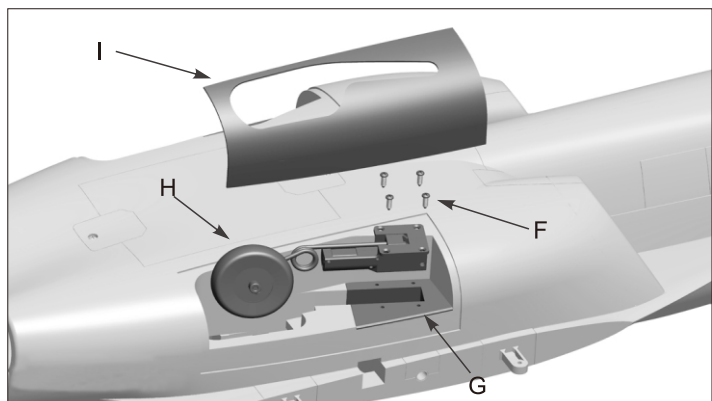
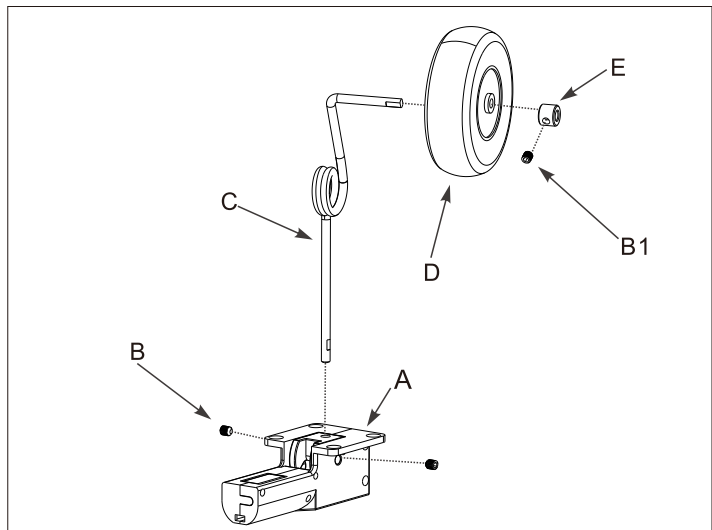

Install power system

EN

1. Install "motor (A)" in "ducted fan housing (B)".
2. Fix motor by 4pcs "screws (C)".
3. Insert te "motor clip (D)" in the motor shaft.
4. Put the "fixed disk (E)" to the "motor clip (D)".
5. then put the "rotor (F)", "spacer (G)" to the "motor clip (D)".
6. Use "nut (H)" to screw the "motor clip (D)" and fix the "rotor (F)".
7. Cover the "spinner (I)", and fix it by "screw (J)".

8. Put the installed "EDF (K)" in the fuselage and fix it by "screws (L)".
9. Connect the ESC and motor, and put the lines in order.
10. Cover the "EDF cover (M)" and "motor cabin fixed part (N)".
11. Fix it by 2pcs "screws (O)".

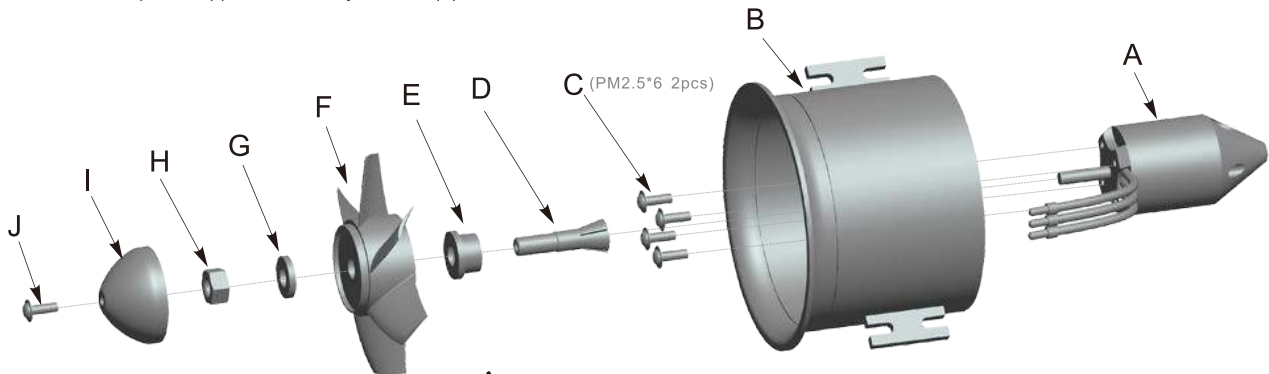

Note: When ESC and battery connected, prohibit to touch them by hand to avoid accidental injury. When test EDF, please use safety test stand for testing, prohibit to touch by hand for testing.

Note: When screw the nut(G), please don't screw too tight, if screw too tight, it may cause the damage of rotor (F).

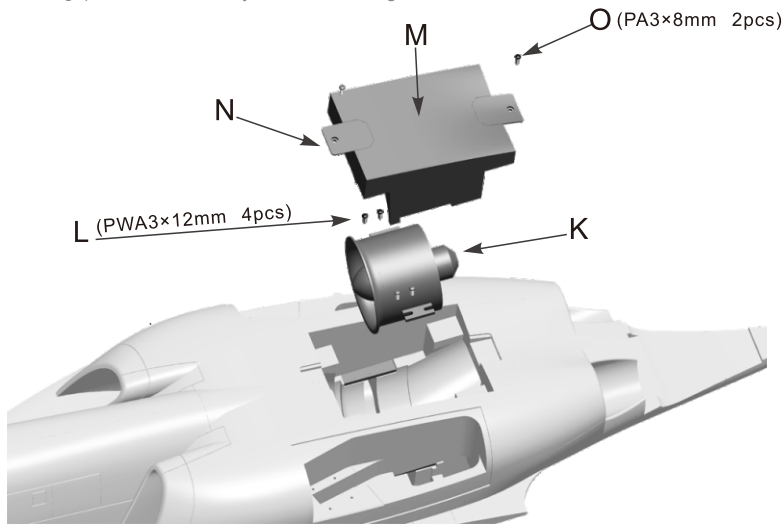

ESC installation diagram

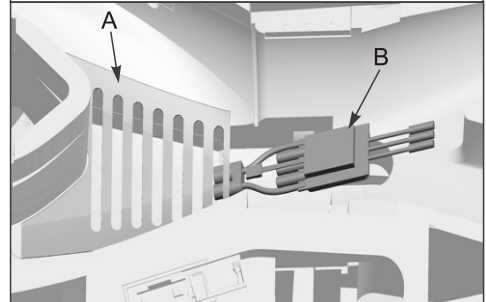

A-Plastic spacer B-Brushless ESC

Connected the ESC and power system and tested. The input of ESC insert through the plastic spacer to reach the battery compartment, and fix it.

Power system

Item No.	EDF Fans	Voltage (V)	Current (A)	Power (W)	Thrust (Kg)	Efficiency (g/w)	Motor Specifications	Rotating speed (rpm)	Weight (g)
E7215	70mm 12-blade EDF	14.8	50	740	1.4~1.6	2.02	2849-2850kv	47000	146
E7212	70mm 6-blade EDF	22.2	50	1100	1.7~1.9	1.63	2849-2200kv	48000	170

Brushless motor install size

Note: If you need to change the motor, please refer to the drawing and specification of right photo, to choose the correct product.

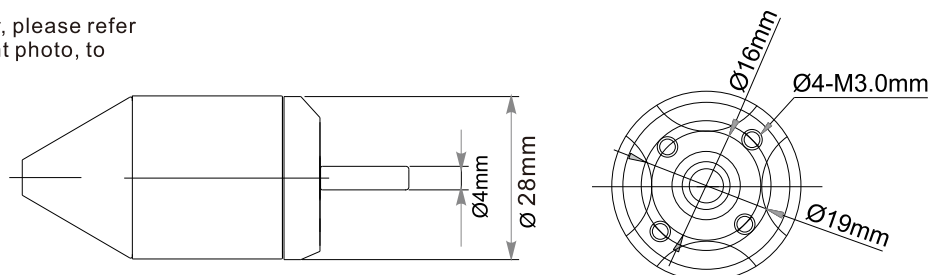

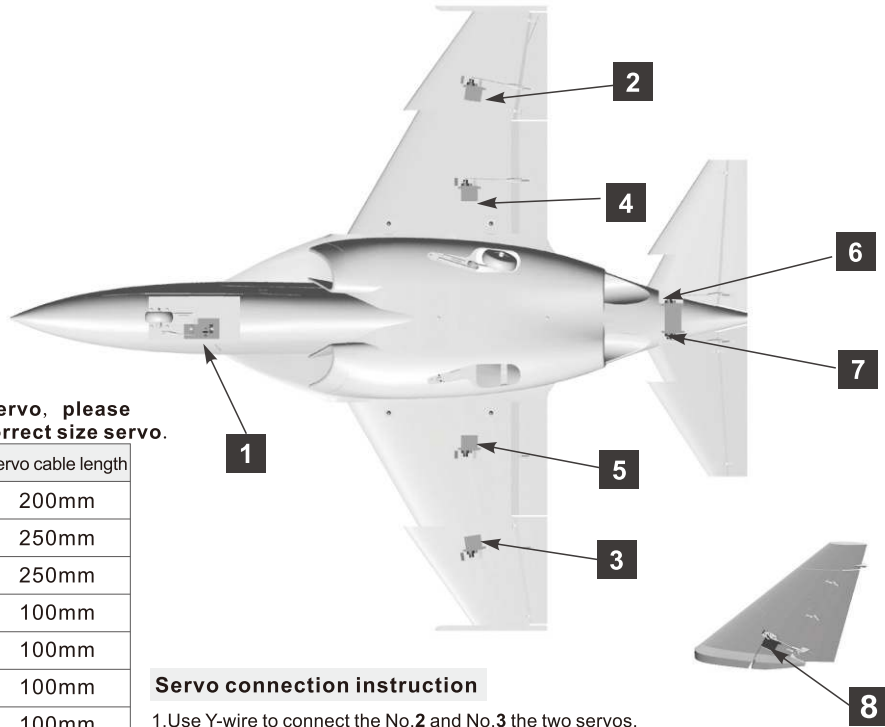
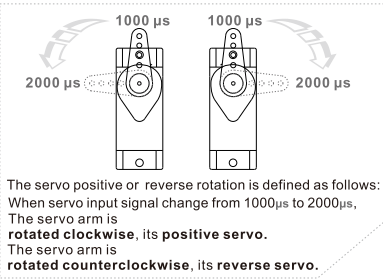

If you need to purchase other brand servo, please refer to the following list to choose correct size servo.

Servo installing position	No.	Pos./Rev.	Servo cable length
Nose gear steering servo	1	Positive	200mm
Aileron servo (Left)	2	Positive	250mm
Aileron servo (Right)	3	Positive	250mm
Flap servo (Left)	4	Positive	100mm
Flap servo (Right)	5	Reverse	100mm
Elevator servo (Left)	6	Positive	100mm
Elevator servo (Right)	7	Reverse	100mm
Rudder servo	8	Positive	200mm

Servo connection instruction

1. Use Y-wire to connect the No.2 and No.3 the two servos.
2. Use Y-wire to connect the No.4 and No.5 the two servos.
2. Use Y-wire to connect the No.6 and No.7 the two servos.

Install on battery

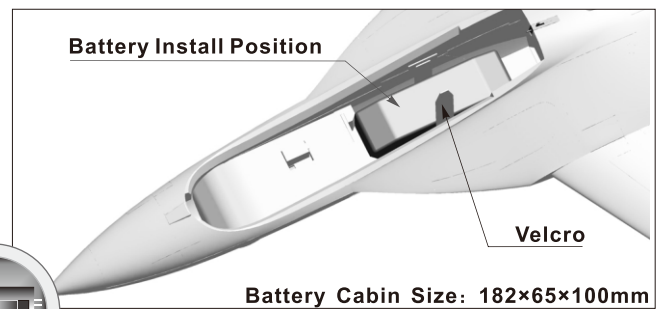
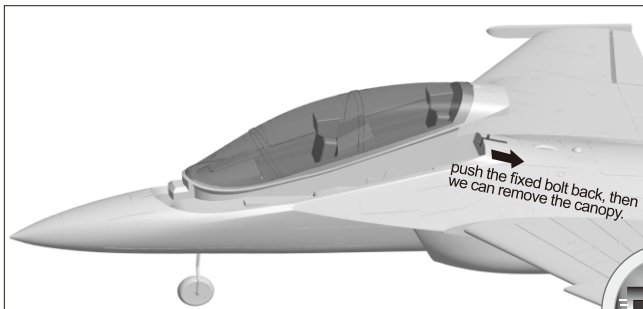

Push the fixed bolt back, remove the canopy, and use Velcro to fix the battery.

Before connect battery and receiver, please switch on the transmitter and check that the throttle is in the low position.

The battery capacity and discharge rate we advise is in the following:

- 4S 14.8V 3300mAh ~ 4S 14.8V 4500mAh
- 6S 22.2V 3300mAh ~ 6S 22.2V 4500mAh

Discharge rate of C ≥ 30C

Center of Gravity

Correct center of gravity is directly related to the success of the flight, please refer to the following CG diagram to adjust your plane's center of gravity.

- You can move the battery forward or backward to adjust the center of gravity.

- If you can not adjust the CG through move the battery, you can also use some other suitable material weight to counterweight, to make sure that CG is in the correct position.

80mm (3-1/5")

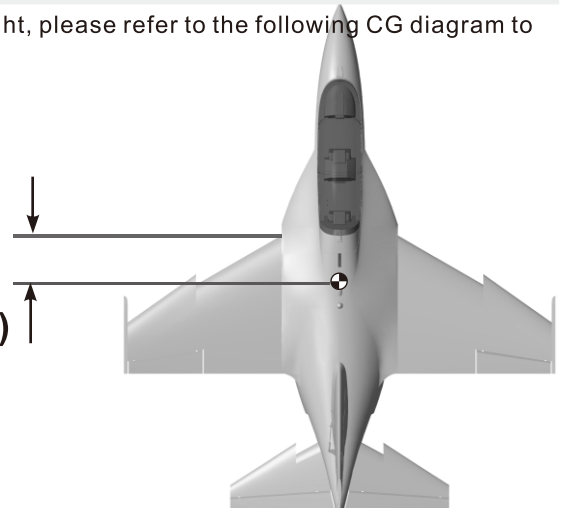

After installed the plane, before flying, we need a fully charged battery and connect to the ESC, then use radio to test and check that every control surface work properly.

Aileron

Stick Left



Stick Right



Elevator

Up Elevator



Down Elevator



Rudder

Stick Left



Stick Right



Optional Flaps

Flaps down

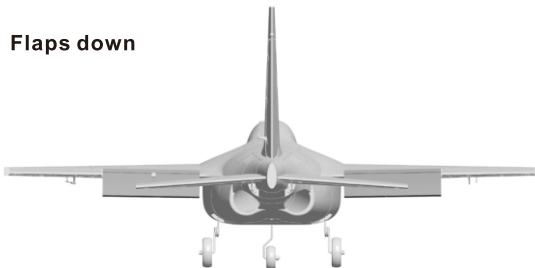

According to our testing experience, according to the following parameters to set the aileron/elevator rate, it will be useful for flight. In low rate, its good for flight control and its suitable for the initial flight or less skilled players. According to your own circumstance, choose one rate in flight.

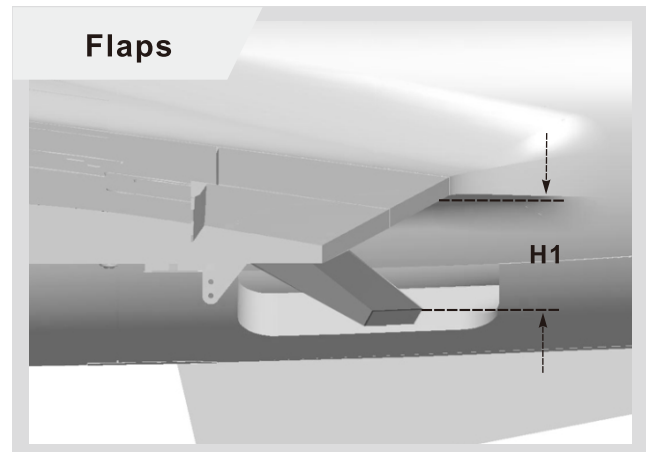
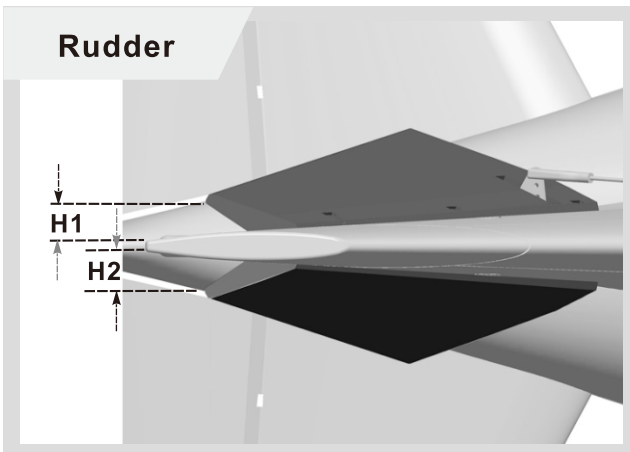
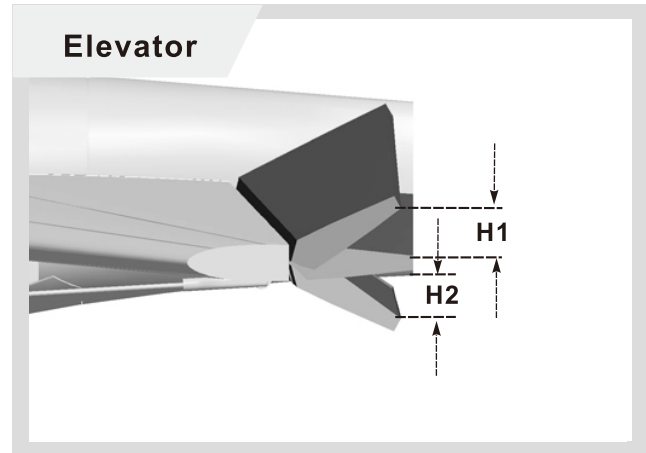
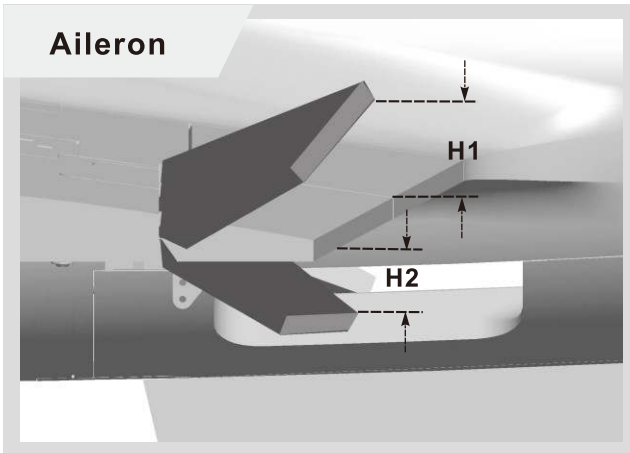

	Aileron	Elevator	Rudder	Flaps
Low Rate	H1/H2 22mm/22mm D/R Rate : 65%	H1/H2 18mm/18mm D/R Rate : 75%	H1/H2 18mm/18mm D/R Rate : 65%	H1 17mm
High Rate	H1/H2 28mm/28mm D/R Rate : 100%	H1/H2 22mm/22mm D/R Rate : 100%	H1/H2 28mm/28mm D/R Rate : 100%	H1 24mm

Motor does not turn on	A) Li-Po battery depleted	A) Recharge Li-Po battery
	B) Transmitter batteries depleted	B) Replace or recharge batteries
	C) Transmitter not turned on	C) Turn on transmitter
	D) Li-Po battery not plugged in	D) Plug in Li-Po battery
	E) Motor not armed	E) Arm motor
	F) A crash has damaged an internal component	F) Replace
	G) ESC or other damaged	G) Check ESC or contact local distributor
Cub is difficult to control	A) You are flying in too much wind	A) Fly when there is no wind
	B) Li-Po battery depleted	B) Recharge Li-Po battery
	C) Transmitter batteries depleted	C) Replace or recharge batteries
	D) Transmitter antenna not extended completely	D) Extend transmitter antenna completely
	E) Surface control rate is too high	E) Use low rate to fly
The nose always move down when fly, always need to up elevator	A) CG is forward	A) Adjust CG backward refer to instruction
Cub constantly climbs or descends, or turns right or left without control input	A) The aircraft is out of trim adjustment	A) Adjust the transmitter trim tabs
	B) You are flying in too much wind	B) Fly when there is no wind
Elevator is too flexible, up and down is not stable	A) CG is backward	A) Adjust CG forward refer to instruction
Plane will be slant when taxi on the runway	A) Nose gear is not center.	A) Center nose gear
	B) Rudder is not center.	B) Center rudder
Take off is difficult	A) Thrust is not on the high position	A) Thrust is on the high position
	B) Taxi distance is not enough	B) Long taxi distance
	C) Elevator rate is not enough high	C) Use high rate of elevator
Cub will not climb	A) Li-Po battery is depleted	A) Recharge Li-Po battery
	B) Ducted fan is damaged	B) Check and replace ducted fan
	C) Motor is damaged	C) Check and replace motor
	D) ESC overheat protection, power reduction.	D) Landing firstly, check and select a more powerful ESC
Li-Po battery is slightly warm after charging	A) This is normal	A) The Li-Po battery may be slightly warm when fully charged. It should not be hot to the touch.
Motor vibrates excessively	A) Ducted fan is damaged	A) Check and replace ducted fan
	B) Motor is damaged	B) Check and replace motor
	C) Ducted fan is not balance	C) Adjust the ducted fan balance
	D) High speed will happen slightly vibrate	D) Its normal to use
Control surface move the wrong direction	A) Servo direction is reversed	A) Adjust servo reversing function



Dongguan Freewing Electronic Technology Ltd
HK Freewing Model International Limited

Add.: FeiYi Building, face to Labor Bureau, Fumin Middle Road, Dalang Town,
Dongguan City, Guangdong Province, China

Web: <http://www.sz-freewing.com>

Email: freewing@sz-freewing.com

Tel: 86-769-82669669 Fax: 86-769-82033233

东莞市飞翼电子科技有限公司
香港飞翼模型国际有限公司

地址: 广东省东莞市大朗镇富民中路402-408号飞翼楼四楼

Web: <http://www.sz-freewing.com>

Email: freewing@sz-freewing.com

Tel: 86-769-82669669 Fax: 86-769-82033233